

Incremental encoders

Solid shaft and flange in inch dimensions

5...6000 pulses per revolution

G25



G25 with MIL-connector

Features

- Robust design with protection up to IP 67
- Solid shaft loading up to 150 lbs (670 N)
- Shock resistant up to 100 g's
- Operating temperature -30...+100 °C
- Max. 6000 pulses per revolution without interpolation

Technical data - electrical ratings

Voltage supply	5 VDC ±10 % 4.75...30 VDC
Reverse polarity protection	Yes (4.75...30 VDC)
Consumption w/o load	≤30 mA (24 VDC) ≤60 mA (5 VDC)
Pulses per revolution	5...6000
Sensing method	Optical
Output frequency	≤150 kHz
Output signals	A, B, Z A, B, Z + inverted
Output stages	Linedriver/RS422 Push-pull short-circuit proof
Interference immunity	DIN EN 61000-6-2
Emitted interference	DIN EN 61000-6-4

Technical data - mechanical design

Size (flange)	2.5 x 2.5" (63.5 x 63.5 mm)
Shaft type	ø0.375" (ø9.52 mm) solid shaft
Admitted shaft load	≤80 lbs (350 N) axial/radial ≤100 lbs (450 N) axial or ≤150 lbs (670 N) radial
Bearing life	1.6 x 10 ¹⁰ rev. at 10 % of rated shaft loading (8 lbs axial/radial)
Flange	Clamping flange square 2.5" x 2.5" (63.5 x 63.5 mm)
Protection DIN EN 60529	IP 54 (without shaft seal), IP 67 (with shaft seal)
Operating speed	≤10000 rpm (IP 54) ≤6000 rpm (IP 67)
Starting torque	≤0.015 Nm (+25 °C, IP 54) ≤0.03 Nm (+25 °C, IP 67)
Rotor moment of inertia	14.5 gcm ²
Materials	Housing: aluminium Flange: aluminium
Operating temperature	-30...+100 °C (5 VDC) -30...+85 °C (24 VDC)
Relative humidity	95 % non-condensing
Resistance	DIN EN 60068-2-6 Vibration 10 g, 10-2000 Hz DIN EN 60068-2-27 Shock 100 g, 6 ms
Connection	MIL-connector, 7-pin MIL-connector, 10-pin Cable 1 m
Weight approx.	12.5 oz., 350 g

Incremental encoders

Solid shaft and flange in inch dimensions

5...6000 pulses per revolution

G25

Part number

G25.

Pulse number - see table

Connection

- A0 MIL connector MS3102 R18-1P
10-pin, axial
- A1 MIL connector MS3102 R18-1P
10-pin, radial
- B0 MIL connector MS3102 R16S-1P
7-pin, axial
- B1 MIL connector MS3102 R16S-1P
7-pin, radial
- 11 Cable 1 m, axial
- 21 Cable 1 m, radial

Voltage supply / signals

- 21 5 VDC / A,B,Z, 90° index Z (MIL connector 7-pin)
- 22 5 VDC / linedriver RS422 / A,B,Z +complement, 90° index Z (MIL connector 10-pin/cable)
- 70 4.75...30 VDC / push-pull / A,B,Z +complement, 90° index Z (MIL connector 10-pin/cable)
- 71 4.75...30 VDC / push-pull / A,B,Z, 90° index Z (MIL connector 7-pin)

Flange / Solid shaft

- 1 Front panel 63.5 x 63.5 mm / 9.52 mm, IP 54
- B Front panel 63.5 x 63.5 mm / 9.52 mm, IP 67

Part number (pulse number)

49 (5)	40 (60)	13 (360)	28 (2000)
36 (10)	41 (100)	15 (500)	29 (2048)
50 (25)	57 (128)	22 (1000)	34 (4096)
39 (50)	06 (200)	23 (1024)	48 (6000)

Other pulse numbers on request.
Example: part number 23 = 1024 pulses.

Accessories

Connectors and cables

Z 172.005 MIL connector, 10-pin, 5 m cable

Incremental encoders

Solid shaft and flange in inch dimensions

5...6000 pulses per revolution

G25

Output signals

Clockwise rotating direction when looking at flange.
Track A, B, Z and complement

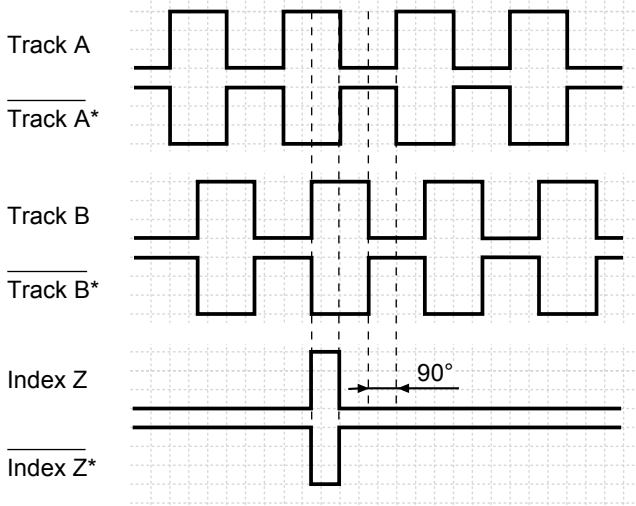

* Version with complementary signals

Trigger level

Outputs	Linedriver RS422
Output level High	>2.5 V (I = -20 mA)
Output level Low	<0.5 V (I = 20 mA)
Load High	<20 mA
Load Low	<20 mA

Outputs	Push-pull short-circuit proof
Output level High	>UB -3 V (I = -20 mA)
Output level Low	<0.5 V (I = 20 mA)
Load High	<20 mA
Load Low	<20 mA

Terminal assignment

MIL-connector

Connector	Assignment 10-pin connector	Assignment 7-pin connector
Pin A	Track A	Track A
Pin B	Track B	Track B
Pin C	Index Z	Index Z
Pin D	Vs	Vs
Pin E	N.C.	N.C.
Pin F	GND	GND
Pin G	Screen	Screen
Pin H	Track A compl.	-
Pin I	Track B compl.	-
Pin J	Index Z compl.	-

Screen: connected to housing

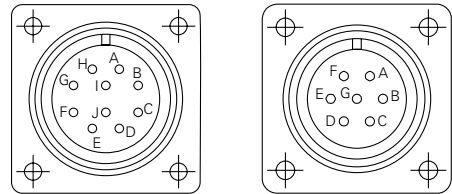

Please use cores twisted in pairs (for example track A / track A compl.) for extension cables.

Cable

Core color	Assignment
green	Track A
grey	Track B
pink	Index Z
red	Vs
blue	GND
brown	Track A compl.
black	Track B compl.
white	Index Z compl.
Screen	

Incremental encoders

Solid shaft and flange in inch dimensions

5...6000 pulses per revolution

G25

Dimensions

G25 with MIL-connector

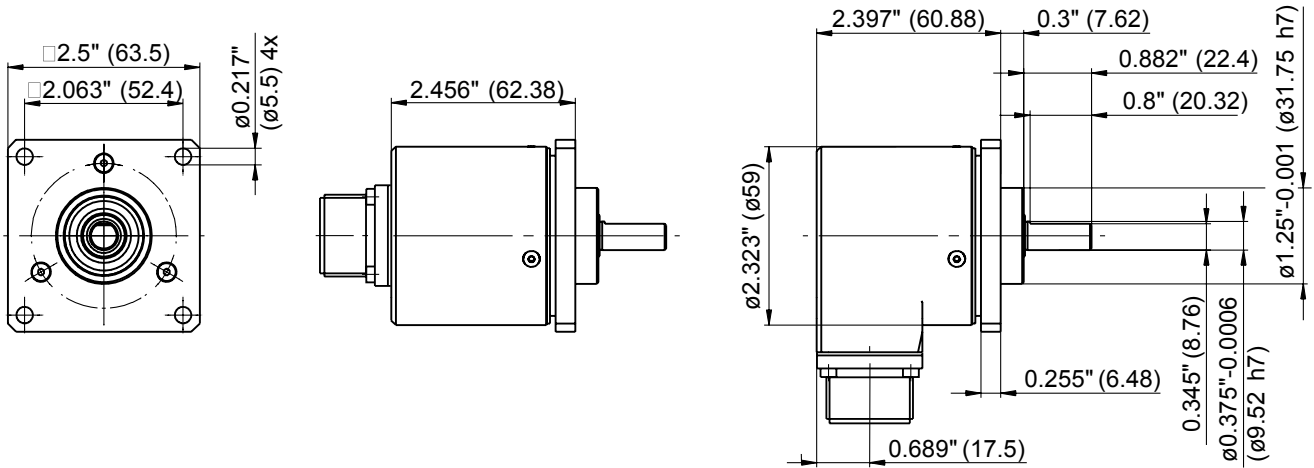

G25 with cable

