

# Incremental encoders

Solid shaft with clamping flange, stainless steel housing

5...6000 pulses per revolution

## GE355



GE355 with clamping flange

### Features

- Encoder with clamping flange
- Stainless steel design
- Optical sensing method
- Max. 6000 pulses per revolution
- Clamping flange with solid shaft  $\varnothing$ 10 mm

### Technical data - electrical ratings

Voltage supply	5 VDC $\pm$ 10 % 4.75...30 VDC 10...30 VDC
Reverse polarity protection	Yes (4.75...30 VDC)
Consumption w/o load	$\leq$ 30 mA (24 VDC) $\leq$ 60 mA (5 VDC)
Pulses per revolution	5...6000
Reference signal	Zero pulse, width 90°
Sensing method	Optical
Output frequency	$\leq$ 150 kHz
Output signals	A 90° B, N + inverted
Output stages	Linedriver/RS422 Push-pull short-circuit proof
Interference immunity	DIN EN 61000-6-2
Emitted interference	DIN EN 61000-6-4
Approval	UL approval / E63076

### Technical data - mechanical design

Size (flange)	$\varnothing$ 58 mm
Shaft type	$\varnothing$ 10 mm solid shaft (clamping flange)
Admitted shaft load	$\leq$ 20 N axial $\leq$ 40 N radial
Flange	Clamping flange
Protection DIN EN 60529	IP 67
Operating speed	$\leq$ 10000 rpm
Starting torque	$\leq$ 0.03 Nm (+25 °C, IP 67)
Rotor moment of inertia	14.5 gcm <sup>2</sup>
Materials	Housing: stainless steel 1.4305 Flange: stainless steel 1.4305
Operating temperature	-25...+85 °C
Relative humidity	95 % non-condensing
Resistance	DIN EN 60068-2-6 Vibration 10 g, 16-2000 Hz DIN EN 60068-2-27 Shock 200 g, 6 ms
Connection	Cable 1 m Cable 1.5 m
Weight approx.	500 g

# Incremental encoders

## Solid shaft with clamping flange, stainless steel housing

### 5...6000 pulses per revolution

**GE355**

#### Part number

GE355. A      

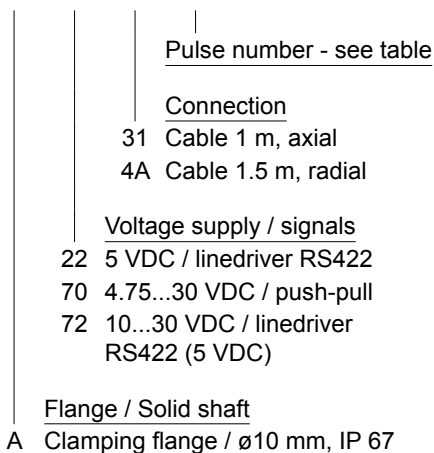

#### Part number (pulse number)

49 (5)	57 (128)	22 (1000)	30 (2500)
36 (10)	06 (200)	23 (1024)	31 (3600)
50 (25)	09 (250)	24 (1250)	34 (4096)
39 (50)	13 (360)	26 (1500)	35 (5000)
40 (60)	14 (400)	28 (2000)	48 (6000)
41 (100)	15 (500)	29 (2048)	

Other pulse numbers on request.  
 Example: part number 23 = 1024 pulses.

# Incremental encoders

Solid shaft with clamping flange, stainless steel housing

5...6000 pulses per revolution

## GE355

### Output signals

Clockwise rotating direction when looking at flange.

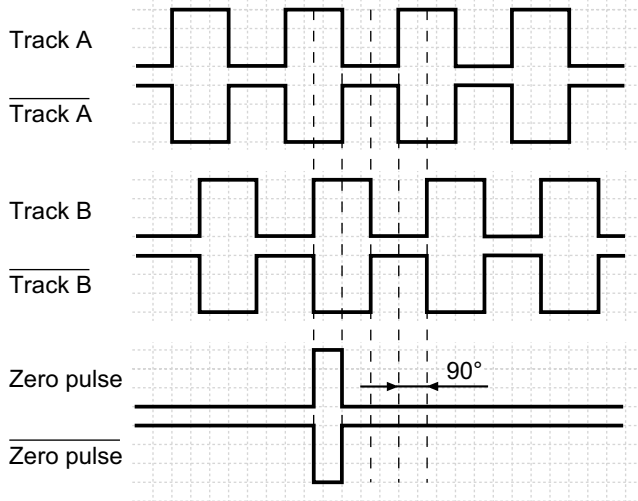

### Terminal assignment

Core colour	Assignment
pink	Track B inv.
blue	UB-Sense
red	Track N (zero pulse)
black	Track N inv. (zero pulse inv.)
brown	Track A
green	Track A inv.
grey	Track B
white/green	GND
white	GND-Sense
brown/green	UB

UB-Sense and GND-Sense are directly connected to UB resp. GND.

Please use cores twisted in pairs (for example track A / track A inv.) for extension cables of more than 10 m length

### Trigger level

Outputs	Linedriver RS422
Output level High	>2.5 V (I = -20 mA)
Output level Low	<0.5 V (I = 20 mA)
Load High / Low	<20 mA

Outputs	Push-pull short-circuit proof
Output level High	>UB -3 V (I = -20 mA)
Output level Low	<0.5 V (I = 20 mA)
Load High / Low	<20 mA

# Incremental encoders

Solid shaft with clamping flange, stainless steel housing  
5...6000 pulses per revolution

GE355

## Dimensions

