

Incremental encoders

Blind hollow shaft up to $\varnothing 14$ mm

5...6000 pulses per revolution

GI330, GI332



GI330 with blind hollow shaft

Features

- Encoder with blind hollow shaft up to $\varnothing 14$ mm
- Optical sensing method
- Max. 6000 pulses per revolution
- Center mounting or by clamping ring
- Cost-efficient mounting

Technical data - electrical ratings

Voltage supply	5 VDC ± 10 % 4.75...30 VDC 10...30 VDC
Reverse polarity protection	Yes (4.75...30 VDC)
Consumption w/o load	≤ 30 mA (24 VDC) ≤ 60 mA (5 VDC)
Pulses per revolution	5...6000
Reference signal	Zero pulse, width 90°
Sensing method	Optical
Output frequency	≤ 150 kHz
Output signals	A 90° B, N + inverted
Output stages	Linedriver/RS422 Push-pull short-circuit proof
Interference immunity	DIN EN 61000-6-2
Emitted interference	DIN EN 61000-6-4
Approval	UL approval / E63076

Technical data - mechanical design

Size (flange)	$\varnothing 58$ mm
Protection DIN EN 60529	IP 54
Operating speed	≤ 6000 rpm
Starting torque	≤ 0.03 Nm ($+25^\circ\text{C}$)
Rotor moment of inertia	14.5 gcm ²
Materials	Housing: aluminium Flange: aluminium
Operating temperature	$-25...+100^\circ\text{C}$ (5 VDC) $-25...+85^\circ\text{C}$ (24 VDC) $-40...+85^\circ\text{C}$ (optional)
Relative humidity	95 % non-condensing
Resistance	DIN EN 60068-2-6 Vibration 10 g, 16-2000 Hz DIN EN 60068-2-27 Shock 200 g, 6 ms
Connection	Connector M23, 12-pin Cable 1 m
Weight approx.	250 g

GI330

Shaft type $\varnothing 12$ mm (blind hollow shaft)

GI332

Shaft type $\varnothing 12$ mm (blind hollow shaft)
 $\varnothing 14$ mm (blind hollow shaft)

Incremental encoders

Blind hollow shaft up to $\varnothing 14$ mm

5...6000 pulses per revolution

GI330, GI332

Part number

Blind hollow shaft with center mounting

GI330.

				<u>Pulse number - see table</u>
				<u>Connection</u>
				C3 Connector M23, 12-pin, radial
				41 Cable 1 m, radial
				<u>Voltage supply / signals</u>
				22 5 VDC / linedriver RS422
				70 4.75...30 VDC / push-pull
				72 10...30 VDC / linedriver RS422 (5 VDC)
				<u>Blind hollow shaft / torque pin</u>
				0 $\varnothing 12$ mm, center mounting, pin 15 mm
				1 $\varnothing 12$ mm, center mounting, pin 9.5 mm
				A $\varnothing 12$ mm, center mounting, without pin

Blind hollow shaft with clamping ring

GI332.

				<u>Pulse number - see table</u>
				<u>Connection</u>
				C3 Connector M23, 12-pin, radial
				41 Cable 1 m, radial
				<u>Voltage supply / signals</u>
				22 5 VDC / linedriver RS422
				70 4.75...30 VDC / push-pull
				72 10...30 VDC / linedriver RS422 (5 VDC)
				<u>Blind hollow shaft / torque pin</u>
				0 $\varnothing 12$ mm, clamping ring on flange, pin 15 mm
				1 $\varnothing 12$ mm, clamping ring on flange, pin 9.5 mm
				A $\varnothing 12$ mm, clamping ring on flange, without pin
				4 $\varnothing 14$ mm, clamping ring on flange, pin 15 mm
				5 $\varnothing 14$ mm, clamping ring on flange, pin 9.5 mm

Part number (pulse number)

49 (5)	06 (200)	17 (600)	30 (2500)
36 (10)	09 (250)	19 (720)	47 (3000)
50 (25)	10 (256)	22 (1000)	31 (3600)
39 (50)	11 (300)	23 (1024)	34 (4096)
40 (60)	13 (360)	24 (1250)	35 (5000)
41 (100)	14 (400)	26 (1500)	48 (6000)
57 (128)	15 (500)	28 (2000)	
05 (180)	16 (512)	29 (2048)	

Other pulse numbers on request.
Example: part number 23 = 1024 pulses.

Accessories

Connectors and cables

Z 141.001	Female connector M23, 12-pin, without cable
Z 141.003	Female connector M23, 12-pin, 2 m cable
Z 141.005	Female connector M23, 12-pin, 5 m cable
Z 141.007	Female connector M23, 12-pin, 10 m cable

Mounting accessories

Z 119.023	Spring coupling for encoders with $\varnothing 58$ mm housing
Z 119.024	Torque support and spring washer for encoders with 9.5 mm pin
Z 119.041	Torque support by rubber buffer for encoders with 15 mm pin

Incremental encoders

Blind hollow shaft up to $\varnothing 14$ mm

5...6000 pulses per revolution

GI330, GI332

Output signals

Clockwise rotating direction when looking at flange.

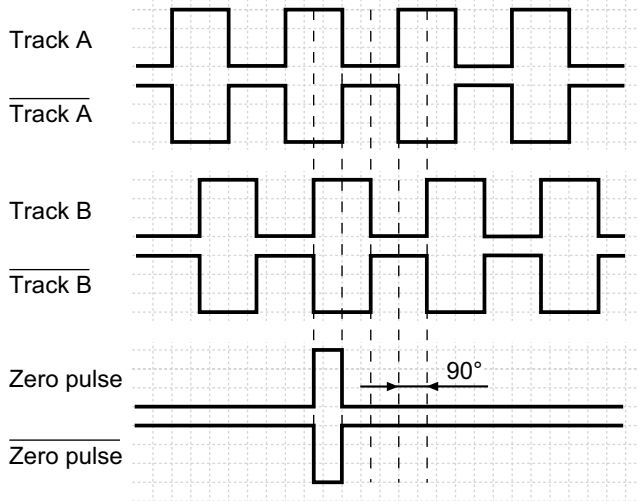

Terminal assignment

Connector	Core colour	Assignment
Pin 1	pink	Track B inv.
Pin 2	blue	UB-Sense
Pin 3	red	Track N (zero pulse)
Pin 4	black	Track N inv. (zero pulse inv.)
Pin 5	brown	Track A
Pin 6	green	Track A inv.
Pin 7	–	–
Pin 8	grey	Track B
Pin 9	–	–
Pin 10	white/green	GND
Pin 11	white	GND-Sense
Pin 12	brown/green	UB

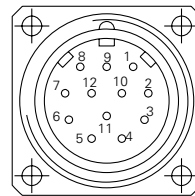

UB-Sense and GND-Sense are directly connected to UB resp. GND. Please use cores twisted in pairs (for example track A / track A inv.) for extension cables of more than 10 m length.

Trigger level

Outputs	Linedriver RS422
Output level High	>2.5 V (I = -20 mA)
Output level Low	<0.5 V (I = 20 mA)
Load High / Low	<20 mA

Outputs	Push-pull short-circuit proof
Output level High	>UB -3 V (I = -20 mA)
Output level Low	<0.5 V (I = 20 mA)
Load High / Low	<20 mA

Incremental encoders

Blind hollow shaft up to $\varnothing 14$ mm
5...6000 pulses per revolution

GI330, GI332

Dimensions

GI330 - blind hollow shaft and center mounting

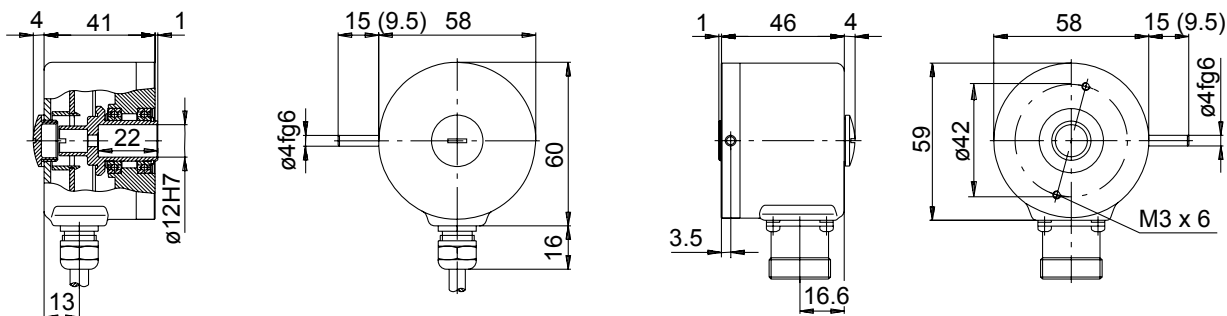

GI332 - blind hollow shaft, clamping ring on flange

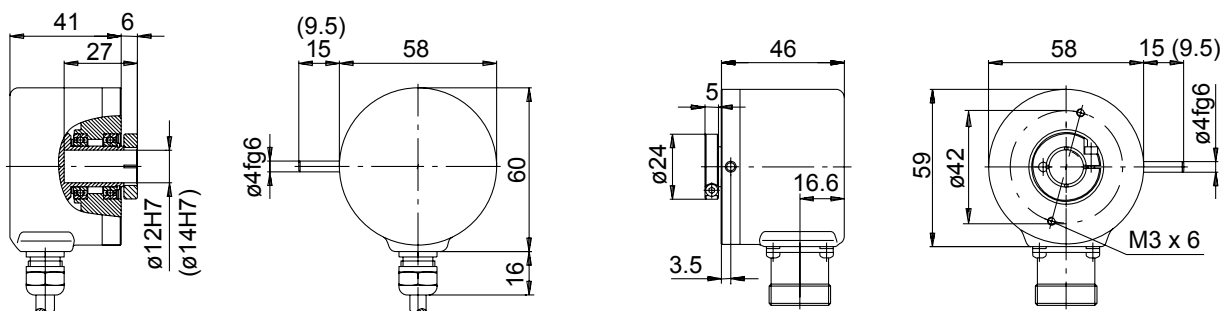

GI330, GI332 - connector dimensions

