

# Incremental encoders

Blind or through hollow shaft up to  $\varnothing 15$  mm

5...2048 pulses per revolution

## GI341, GI342



GI342 with through hollow shaft

### Technical data - electrical ratings

Voltage supply	5 VDC $\pm 10$ % 4.75...30 VDC 10...30 VDC
Reverse polarity protection	Yes (4.75...30 VDC)
Consumption w/o load	$\leq 30$ mA (24 VDC) $\leq 60$ mA (5 VDC)
Pulses per revolution	5...2048
Reference signal	Zero pulse, width $90^\circ$
Sensing method	Optical
Output frequency	$\leq 150$ kHz
Output signals	A $90^\circ$ B, N + inverted
Output stages	Linedriver/RS422 TTL Push-pull short-circuit proof
Interference immunity	DIN EN 61000-6-2
Emitted interference	DIN EN 61000-6-4
Approval	UL approval / E63076

### Features

- Encoder with blind or through hollow shaft  $\varnothing 10...15$  mm
- Max. 2048 pulses per revolution
- Optical sensing method
- Flange and housing made of high-tech plastics
- Tangential cable output
- Available with commutation signals
- Mounting depth 40 mm

### Optional

- Commutation tracks UVW
- Temperature max.  $120^\circ\text{C}$  (only GI341)

### Technical data - mechanical design

Size (flange)	$\varnothing 58$ mm
Protection DIN EN 60529	IP 54
Operating speed	$\leq 6000$ rpm
Rotor moment of inertia	60 gcm <sup>2</sup>
Material	Housing: carbon-fibre reinforced polyamide
Operating temperature	$-20...+80^\circ\text{C}$
Relative humidity	95 % non-condensing
Resistance	DIN EN 60068-2-6 Vibration 10 g, 16-2000 Hz DIN EN 60068-2-27 Shock 200 g, 6 ms
Connection	Cable 1 m
Weight approx.	150 g

### GI341

Shaft type	$\varnothing 10...15$ mm (blind hollow shaft)
Starting torque	$\leq 0.015$ Nm ( $+25^\circ\text{C}$ )

### GI342

Shaft type	$\varnothing 10...15$ mm (through hollow shaft)
Starting torque	$\leq 0.05$ Nm ( $+25^\circ\text{C}$ )

# Incremental encoders

## Blind or through hollow shaft up to $\varnothing 15$ mm

### 5...2048 pulses per revolution

GI341, GI342

#### Part number

##### Blind hollow shaft

GI341.    71

Pulse number - see table

Connection

71 Cable 1 m, tangential

Voltage supply / signals

22 5 VDC / linedriver RS422

70 4.75...30 VDC / push-pull

72 10...30 VDC / linedriver  
RS422 (5 VDC)

Blind hollow shaft

A  $\varnothing 12$  mm, center mounting

B  $\varnothing 10$  mm, center mounting

C  $\varnothing 14$  mm, center mounting

G  $\varnothing 15$  mm, center mounting

##### Through hollow shaft

GI342.   71

Pulse number - see table

Connection

71 Cable 1 m, tangential

Voltage supply / signals

22 5 VDC / linedriver RS422

70 4.75...30 VDC / push-pull

72 10...30 VDC / linedriver  
RS422 (5 VDC)

Through hollow shaft

A  $\varnothing 12$  mm, clamping ring on flange

B  $\varnothing 10$  mm, clamping ring on flange

C  $\varnothing 14$  mm, clamping ring on flange

G  $\varnothing 15$  mm, clamping ring on flange

#### Part number (pulse number)

49 (5)	41 (100)	14 (400)	26 (1500)
36 (10)	57 (128)	15 (500)	29 (2048)
50 (25)	06 (200)	22 (1000)	
39 (50)	09 (250)	23 (1024)	
40 (60)	13 (360)	24 (1250)	

Other pulse numbers on request.

Example: part number 23 = 1024 pulses.

Configurations with commutation tracks on request

#### Accessories

##### Mounting accessories

Z 119.023	Spring coupling for encoders with $\varnothing 58$ mm housing
Z 119.036	Rubber buffer element 7.5 mm long, as torque support
Z 119.040	Shoulder screw M5 as torque support
Z 119.068	Spring coupling for motor's fan guard

# Incremental encoders

Blind or through hollow shaft up to  $\varnothing 15$  mm

5...2048 pulses per revolution

## GI341, GI342

### Output signals

Clockwise rotating when looking at flange.  
Incremental signals

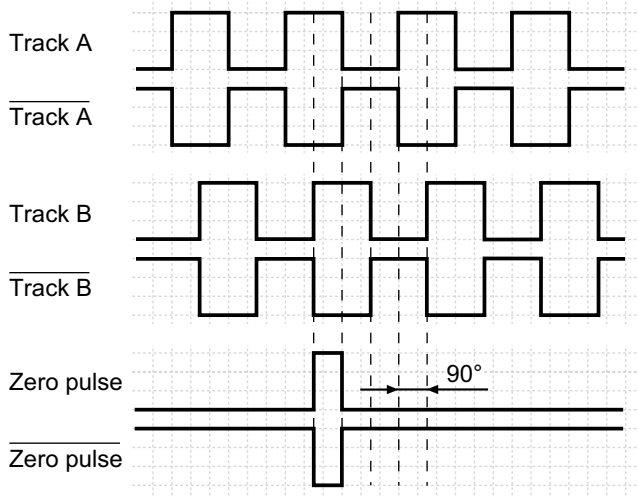

Commutation signals (optional)

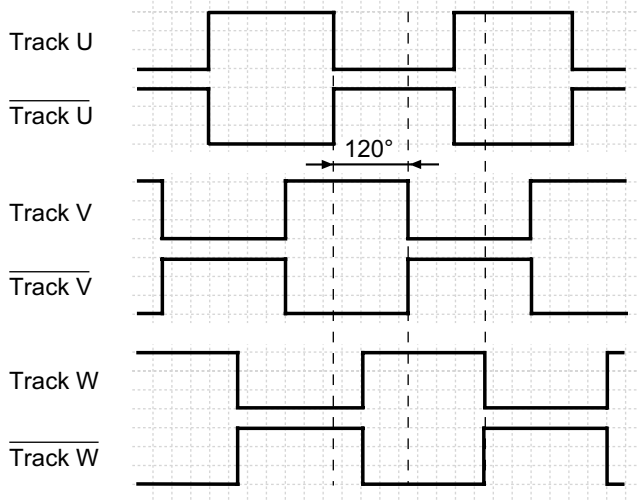

### Terminal assignment

#### Without commutating tracks

Core colour	Assignment
grey	Track B
pink	Track B inv.
red	Track N (zero pulse)
black	Track N inv. (zero pulse inv.)
brown	Track A
green	Track A inv.
white/green	GND
brown/green	UB

#### With commutating tracks

Core colour	Assignment
brown/green	UB
red	Track N (zero pulse)
black	Track N inv. (zero pulse inv.)
brown	Track A
green	Track A inv.
pink	Track B inv.
grey	Track B
white/green	GND
white	Track W inv.
yellow	Track W
blue	Track V
violet	Track V inv.
grey/pink	Track U inv.
red/blue	Track U

Please use cores twisted in pairs (for example track A / track A inv.) for extension cables of more than 10 m length.

### Trigger level

Outputs	Linedriver RS422
Output level High	>2.5 V (I = -20 mA)
Output level Low	<0.5 V (I = 20 mA)
Load High / Low	<20 mA

Outputs	Push-pull short-circuit proof
Output level High	>UB -3 V (I = -20 mA)
Output level Low	<0.5 V (I = 20 mA)
Load High / Low	<20 mA

# Incremental encoders

Blind or through hollow shaft up to  $\varnothing 15$  mm  
5...2048 pulses per revolution

GI341, GI342

## Dimensions

### GI341 - blind hollow shaft

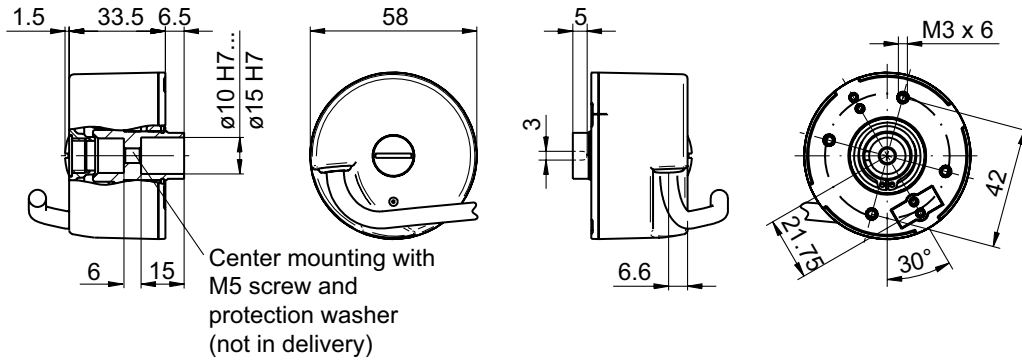

### GI342 - through hollow shaft

