

Incremental encoders

Through hollow shaft $\varnothing 10$ to $\varnothing 14$ mm
100...80000 pulses per revolution

ITD21H00

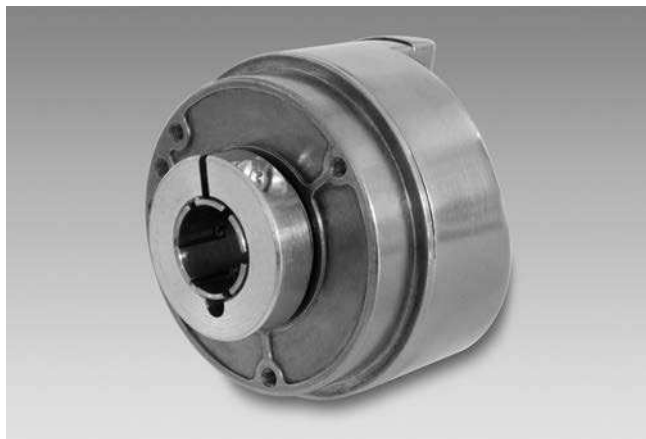

ITD21H00 with through hollow shaft

Features

- Size $\varnothing 58$ mm
- Precise optical sensing
- Output signal level TTL or HTL
- Through hollow shaft $\varnothing 10...14$ mm
- Max. 80000 pulses per revolution
- Operating temperature $-30...+100$ °C
- Detachable cable – tangential outlet
- Top flexibility with numerous models

Technical data - electrical ratings

Voltage supply	5 VDC ± 5 % 8...30 VDC
Reverse polarity protection	Yes
Consumption w/o load	≤ 100 mA
Pulses per revolution	100...80000
Reference signal	Zero pulse, width 90°
Sensing method	Optical
Output frequency	≤ 300 kHz (TTL) ≤ 160 kHz (HTL)
Output signals	A, B, N + inverted
Output stages	TTL linedriver (short-circuit proof) HTL push-pull (short-circuit proof)
Interference immunity	DIN EN 61000-6-2
Emitted interference	DIN EN 61000-6-3

Technical data - mechanical design

Size (flange)	$\varnothing 58$ mm
Shaft type	$\varnothing 10$ mm (through hollow shaft) $\varnothing 12$ mm (through hollow shaft) $\varnothing 14$ mm (through hollow shaft)
Motor shaft tolerance	0.25 mm axial 0.1 mm radial
Protection DIN EN 60529	IP 65
Operating speed	≤ 6000 rpm
Starting torque	≤ 0.015 Nm ($+20$ °C)
Materials	Housing: aluminium Shaft: stainless steel
Operating temperature	$-30...+100$ °C
Relative humidity	90 % non-condensing
Resistance	DIN EN 60068-2-6 Vibration 20 g, 60-2000 Hz DIN EN 60068-2-27 Shock 100 g, 6 ms
Connection	Board connector, 8-pin
Weight approx.	150 g

Incremental encoders

Through hollow shaft $\varnothing 10$ to $\varnothing 14$ mm
100...80000 pulses per revolution

ITD21H00

Part number

ITD21H00

		NI	S21SG8	E		IP65
--	--	----	--------	---	--	------

Protection

IP65 IP 65

Through hollow shaft

10 $\varnothing 10$ mm

12 $\varnothing 12$ mm

14 $\varnothing 14$ mm

Operating temperature

E -30...+100 °C

Connection

S21SG8 Board connector type 21, pin contacts, straight, 8-pin

Output signals

NI A, A inv, B, B inv, 0, 0 inv

Voltage supply / signals

T 5 VDC / TTL level, linedriver

H 8...30 VDC / HTL level, push-pull

R 8...30 VDC / TTL level, linedriver

Pulse number - see table

Pulse number

100	400	1024	2500	10000*
120	500	1200	3000	15000*
150	512	1250	3600	16384*
200	600	1440	4000	20000*
250	720	1500	4096	25000*
256	800	1800	5000	40000*
300	900	2000	6000	80000*
360	1000	2048	8192	

* Pulse numbers are interpolated.

Incremental encoders

Through hollow shaft $\varnothing 10$ to $\varnothing 14$ mm

100...80000 pulses per revolution

ITD21H00

Accessories

Connectors and cables

11072169	Connection cable with FCI, 8-pin / wire end sleeves (UL/CSA), 1 m
11093848	Connection cable with FCI, 8-pin / wire end sleeves (UL/CSA), 2 m
11092928	Connection cable with FCI, 8-pin / wire end sleeves (UL/CSA), 3 m
11077007	Connection cable with FCI, 8-pin / wire end sleeves (UL/CSA), 5 m
11080879	Connection cable with FCI, 8-pin / wire end sleeves (UL/CSA), 10 m
11079089	Connection cable with rear mount socket M23, 12-pin, 1 m
11106562	Connection cable with FCI, 8-pin / D-SUB, 9-pin, 0.3 m
11079111	Connection cable with FCI, 8-pin / D-SUB, 9-pin, 1 m
11079112	Connection cable with crimp contacts (UL/CSA), 0.2 m
11104310	Connection cable with coupling M12, 4-pin, 0.7 m
11079113	Connection cable with coupling M12, 8-pin, 1 m

Mounting accessories

11066080	Torque arm, 1-arm, bolt circle $\varnothing 76$...80 mm, mounting M4 (mounting kit 002)
11066083	Torque arm, 1-arm, bolt circle $\varnothing 74$...94 mm, mounting M4/M5 (mounting kit 006)
11073114	Torque arm, 3-armed, bolt circle $\varnothing 76$ mm, mounting M3 (mounting kit 019)
11073119	Torque arm, 1-arm, bolt circle $\varnothing 65.5$...281 mm, mounting M4, can be cut to length (mounting kit 021)
11069239	Torque arm, 1-arm, bolt circle $\varnothing 110$...130 mm, mounting M5 (mounting kit 092)

Further connection cable lengths see accessories.

Output signals

Clockwise rotation when looking at the mounting side.

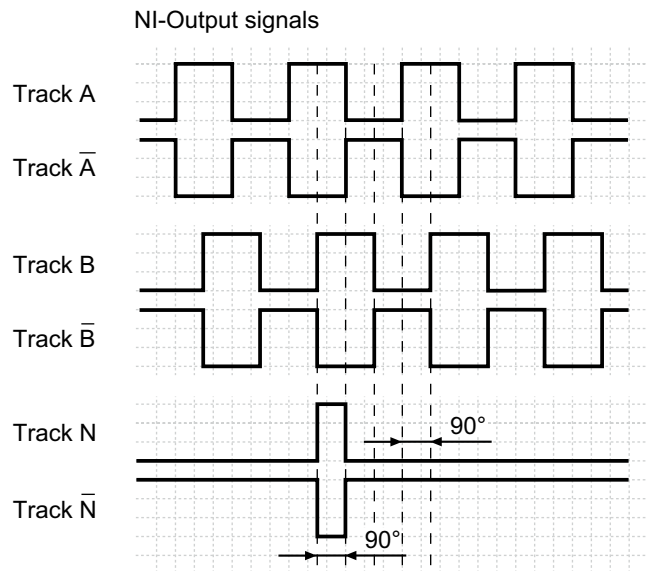

Terminal assignment

Connector	Assignment
Pin 1	UB
Pin 2	GND
Pin 3	Track A
Pin 4	Track A inv.
Pin 5	Track B
Pin 6	Track B inv.
Pin 7	Track N
Pin 8	Track N inv.

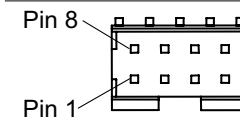

Trigger level

Outputs	Linedriver
Output level High	≥ 2.4 V
Output level Low	≤ 0.5 V
Load	≤ 70 mA

Outputs	Push-pull short-circuit proof
Output level High	$\geq UB - 3$ V
Output level Low	≤ 1.5 V
Load	≤ 70 mA

Incremental encoders

Through hollow shaft $\varnothing 10$ to $\varnothing 14$ mm
100...80000 pulses per revolution

ITD21H00

Dimensions

