

# Incremental encoders

## Blind hollow shaft $\varnothing 10$ to $\varnothing 14$ mm

### 50...1024 pulses per revolution

#### ITD 20 A 4 Y36



ITD 20 A 4 Y36 with blind hollow shaft

#### Technical data - electrical ratings

Voltage supply	5 VDC $\pm 5\%$ 8...30 VDC
Reverse polarity protection	Yes
Consumption w/o load	$\leq 100$ mA
Pulses per revolution	50...1024
Reference signal	Zero pulse, width $90^\circ$
Sensing method	Optical
Output frequency	$\leq 120$ kHz
Output signals	A, B, N + inverted
Output stage	TTL linedriver (short-circuit proof) HTL push-pull (short-circuit proof)
Interference immunity	DIN EN 61000-6-2
Emitted interference	DIN EN 61000-6-3

#### Features

- Encoder with blind hollow shaft  $\varnothing 10...14$  mm
- Max. 1024 pulses per revolution
- Optical sensing
- Mounting by torque support
- TTL or HTL output signals
- Cable output radial

#### Optional

- Cable with connector

#### Technical data - mechanical design

Size (flange)	$\varnothing 58$ mm
Shaft type	$\varnothing 10$ mm (blind hollow shaft) $\varnothing 12$ mm (blind hollow shaft) $\varnothing 14$ mm (blind hollow shaft)
Motor shaft tolerance	0.25 mm axial 0.1 mm radial
Mounting kit	006
Protection DIN EN 60529	IP 65
Operating speed	$\leq 8000$ rpm
Starting torque	$\leq 0.01$ Nm ( $+20^\circ\text{C}$ )
Materials	Housing: aluminium, black, powder-coated Shaft: stainless steel
Operating temperature	$-20...+70^\circ\text{C}$
Relative humidity	90 % non-condensing
Resistance	DIN EN 60068-2-6 Vibration 10 g, 55-2000 Hz DIN EN 60068-2-27 Shock 100 g, 11 ms
Connection	Cable 1 m
Weight approx.	280 g

# Incremental encoders

Blind hollow shaft  $\varnothing 10$  to  $\varnothing 14$  mm  
50...1024 pulses per revolution

ITD 20 A 4 Y36

## Part number

ITD 20 A 4 Y36 

			KR1	S		IP65	006
--	--	--	-----	---	--	------	-----

Mounting kit  
006 Mounting accessory kit 006

Protection  
IP65 IP 65

Blind hollow shaft  
10  $\varnothing 10$  mm  
12  $\varnothing 12$  mm  
14  $\varnothing 14$  mm

Operating temperature  
S -20...+70 °C

Connection  
KR1 Cable 1 m, radial

Output signals  
BI A, A inv, B, B inv  
NI A, A inv, B, B inv, 0, 0 inv

Voltage supply / signals  
T 5 VDC / TTL level, linedriver  
H 8...30 VDC / HTL level, push pull  
R 8...30 VDC / TTL level, linedriver

Pulse number - see table

## Pulse number

50	90	200	360	600
60	100	250	400	1000
64	120	254	500	1024
88	128	256	512	

# Incremental encoders

## Blind hollow shaft $\varnothing 10$ to $\varnothing 14$ mm

### 50...1024 pulses per revolution

#### ITD 20 A 4 Y36

##### Output signals

Clockwise rotation when looking at the mounting side.

##### BI-Output signals

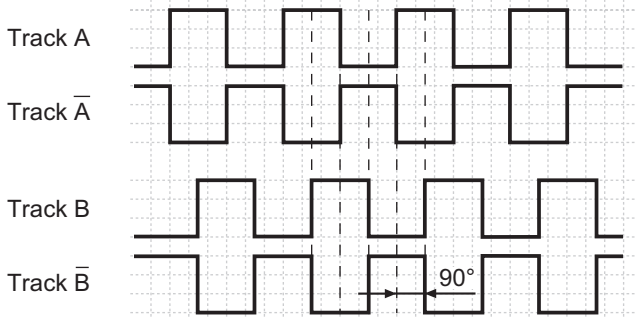

##### NI-Output signals

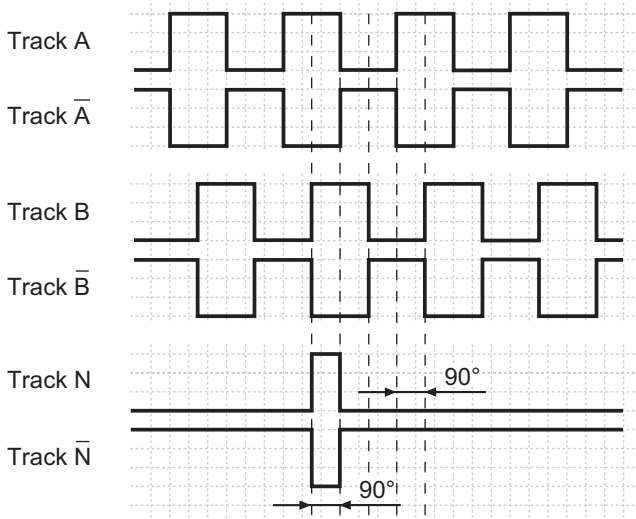

##### Terminal assignment

Core colour	Assignment
brown	Track A
green	Track A inv.
grey	Track B
pink	Track B inv.
red	Track N
black	Track N inv.
brown 0,5 mm <sup>2</sup>	UB
white 0,5 mm <sup>2</sup>	GND
blue	UB-Sense
white	GND-Sense
transparent	Shield/Housing

##### Trigger level

Outputs	Linedriver
Output level High	$\geq 2.4$ V
Output level Low	$\leq 0.5$ V
Load	$\leq 70$ mA

Outputs	Push-pull short-circuit proof
Output level High	$\geq UB - 3$ V
Output level Low	$\leq 1.5$ V
Load	$\leq 70$ mA

##### Dimensions

mounting side  
(proposition)

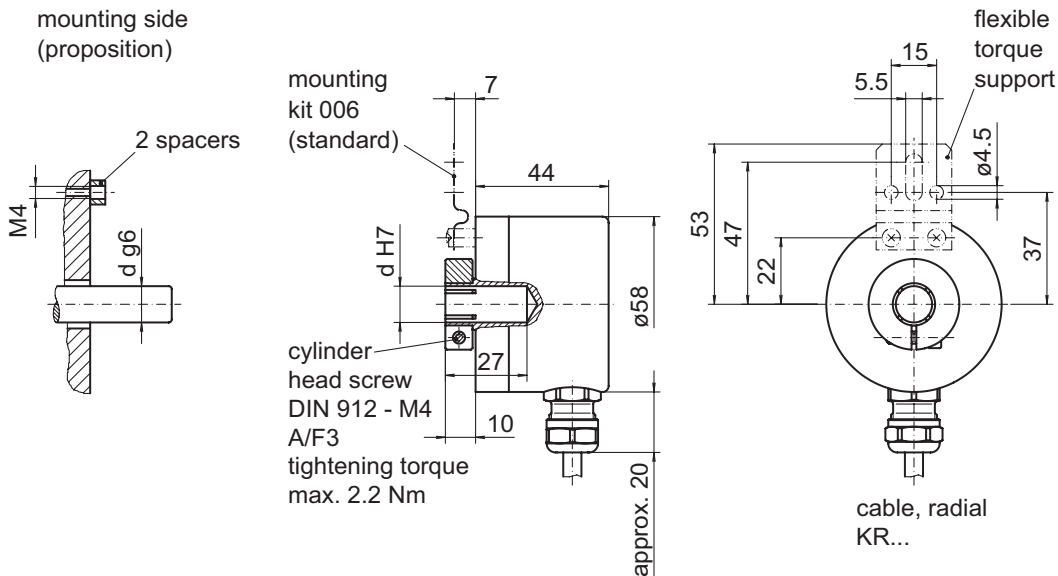

029- 1 Y36

**Incremental encoders**  
Blind hollow shaft  $\varnothing 10$  to  $\varnothing 14$  mm  
50...1024 pulses per revolution

**ITD 20 A 4 Y36**

---