

Sine encoders

Blind hollow shaft $\varnothing 10$ to $\varnothing 16$ mm

1024, 2048 sinewave cycles per turn

ITD 42 A 4



ITD 42 A 4 with blind hollow shaft

Technical data - electrical ratings

Voltage supply	5 VDC ± 10 % 8...30 VDC
Reverse polarity protection	Yes
Consumption w/o load	≤ 90 mA
Sinewave cycles per turn	1024...2048
Sensing method	Optical
Output frequency	≤ 180 kHz (-3 dB)
Output signals	A, B, 0
Output stage	SinCos 1 Vpp

Features

- Encoder with blind hollow shaft $\varnothing 10$...16 mm
- Max. 2048 sinewaves cycles per turn
- Sine output signals 1 Vpp
- Mounting by torque support
- Cable output radial

Optional

- Cable with connector

Technical data - mechanical design

Size (flange)	$\varnothing 80$ mm
Shaft type	$\varnothing 10$...16 mm (blind hollow shaft)
Motor shaft tolerance	0.25 mm axial 0.1 mm radial
Mounting kit	050
Protection DIN EN 60529	IP 65
Operating speed	≤ 8000 rpm
Starting torque	≤ 0.01 Nm (+20 °C)
Materials	Housing: aluminium, black, powder-coated Shaft: stainless steel
Operating temperature	-20...+85 °C
Relative humidity	90 % non-condensing
Resistance	DIN EN 60068-2-6 Vibration 10 g, 55-2000 Hz DIN EN 60068-2-27 Shock 30 g, 11 ms
Connection	Cable 1 m
Weight approx.	550 g

Sine encoders

Blind hollow shaft $\varnothing 10$ to $\varnothing 16$ mm
1024, 2048 sinewave cycles per turn

ITD 42 A 4

Part number

ITD 42 A 4

		NI		S		IP65	050
--	--	----	--	---	--	------	-----

Mounting kit

050 Mounting accessory kit 050

Protection

IP65 IP 65

Blind hollow shaft

10 $\varnothing 10$ mm

11 $\varnothing 11$ mm

12 $\varnothing 12$ mm

12.7 $\varnothing 12.7$ mm

14 $\varnothing 14$ mm

15 $\varnothing 15$ mm

16 $\varnothing 16$ mm

Operating temperature

S -20...+85 °C

Connection

KR1 Cable 1 m, radial

KA1 Cable 1 m, axial

Output signals

NI A+, A-, B+, B-, N+, N-

Voltage supply / signals

M 5 VDC / sine 1 Vpp

S 8...30 VDC / sine 1 Vpp

Sinewave cycles - see table

Sinewave cycles

1024 | 2048

Sine encoders

Blind hollow shaft $\varnothing 10$ to $\varnothing 16$ mm

1024, 2048 sinewave cycles per turn

ITD 42 A 4

Output signals

Clockwise rotation when looking at the mounting side.

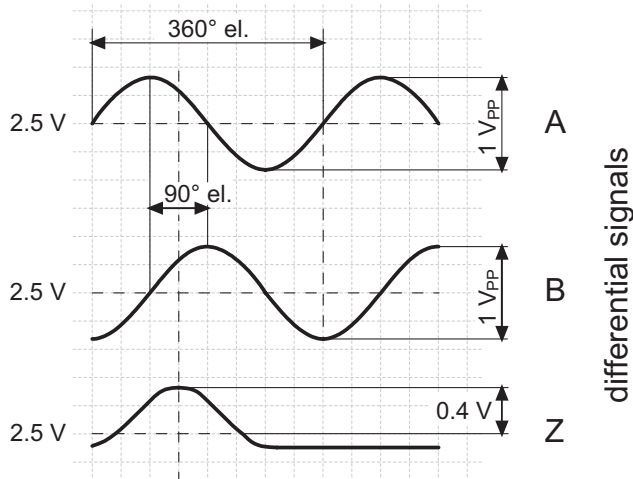

Terminal assignment

Core colour	Assignment
green	Track A +
brown	Track A -
grey	Track B +
black	Track B -
pink	Track N +
white	Track N -
red	UB
blue	GND
yellow	UB-Sense
violet	GND-Sense
transparent	Shield/Housing

Output signal level

Outputs	Sine
Output amplitude A + B	1 V _{PP} at Z ₀ = 120 Ω
Output amplitude N	approx. 0,4 V (useable part) at Z ₀ = 120 Ω

Dimensions

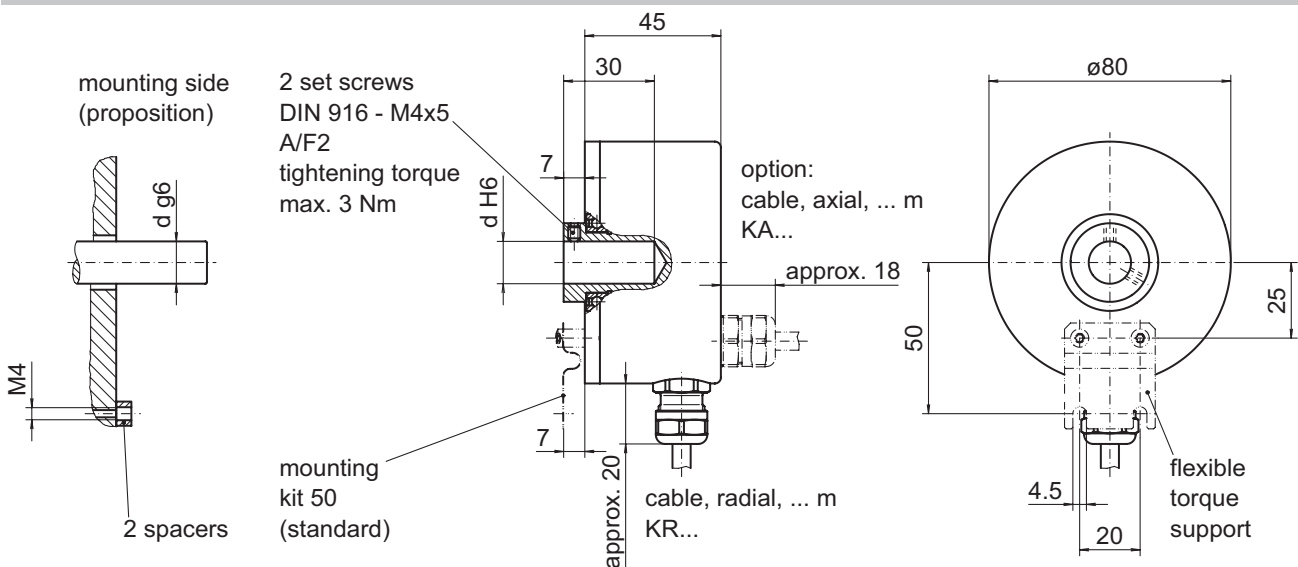

026-5

Sine encoders
Blind hollow shaft $\varnothing 10$ to $\varnothing 16$ mm
1024, 2048 sinewave cycles per turn

ITD 42 A 4
