

Installation instruction protective cover HS35

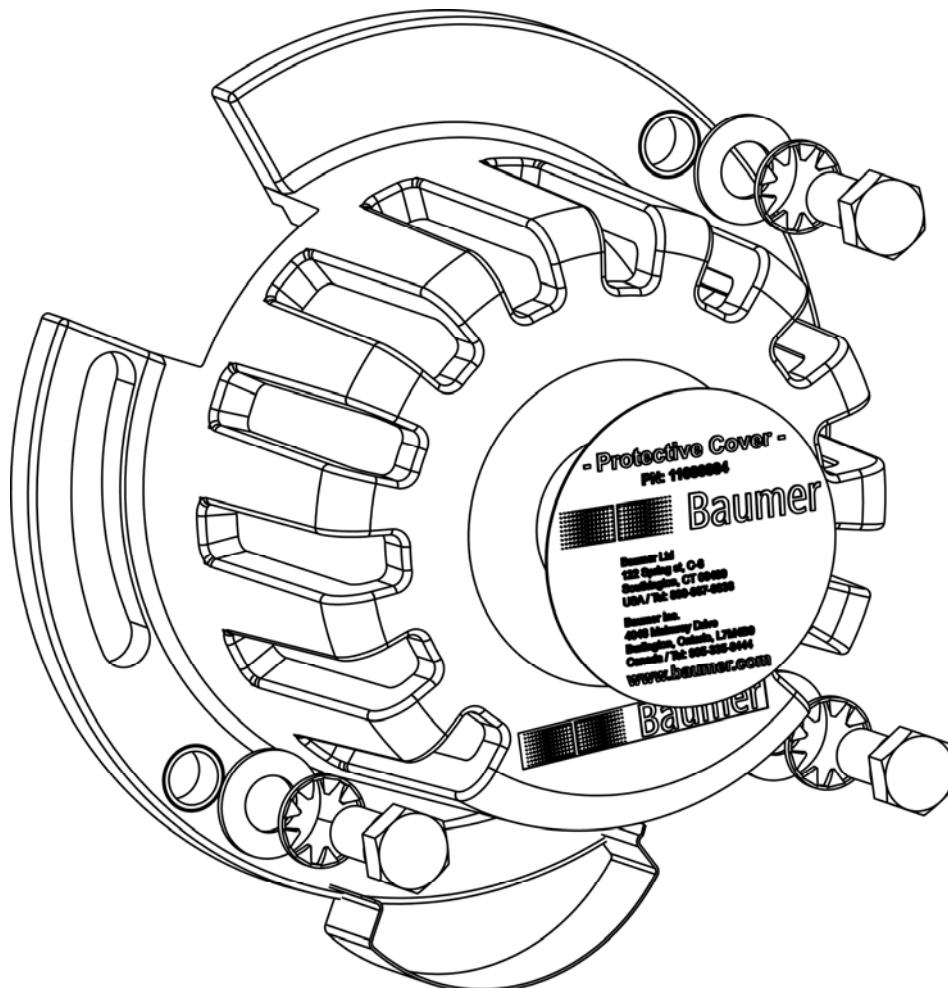

Features

Protective cover for encoder HS35 – matched for motor flange NEMA 56C (4,5“) and fan cover.
For attachment to a fan cover hammer head bolts are recommended (not included).

Scope of delivery

- 1x protective cover HS35
- 1x contact protection clip
- 3x cylinder screw (0.75 inch long)
- 3x flat washer
- 3x lock washer
- 1x protective label

Mounting protective cover HS35

- The incremental encoder must be slide on to driveshaft by hand. Do not force! If necessary check and verify the driveshaft diameter.
- The torque support on mounting side (e.g. motor B-shield) shown in graphic [1] fastening without pressure. Tightening torque max. 1700 oz-in (max. 12 Nm).
- The incremental encoder shaft fastening with the clamping ring on the motor shaft. Tightening torque of the clamping ring screw max. 312 oz-in (2.2 Nm).

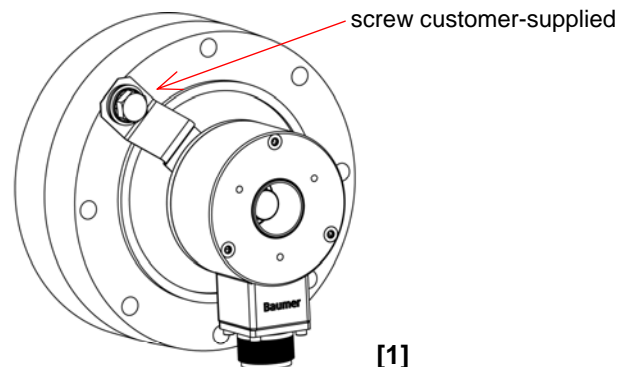

- Protective cover according to graphics[2] put on the mounting side and attach with the supplied accessories (3x cylinder screw (0.75 inch long) with flat washer and lock washer). Tightening torque max. 2690 oz-in (max. 19 Nm).

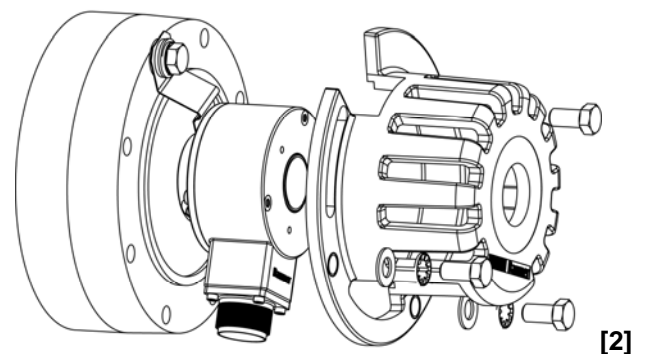

- Set the contact protection clip into the opening of the protective cover (connector/cable gland) (graphics [3]).

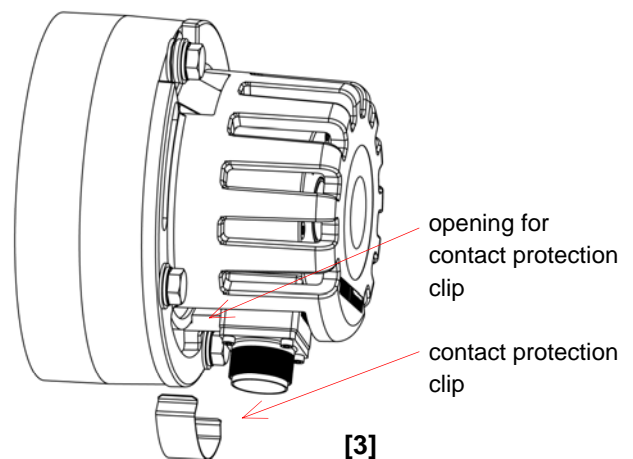

- Protection label glue centred on the opening of the protective cover (graphics [4]).

