

Square Body DC Fuses — 1200Vdc: 160-420A

1200Vdc 160-420A

Specifications

Description: High speed fuses that provides superior protection in light and heavy harsh DC traction applications as 1200Vdc and below circuits, and as DC link/power converters.

Dimensions: See dimensions illustration.

Ratings:

Volts: — 1200Vdc

Amps: — 160-420A

IR: — 1200Vdc = 100kA L/R: 15 ms.

Agency Information: Consult Cooper Bussmann.

Electrical Characteristics

Arc Voltage

This curve gives the peak arc voltage, U_L , which may appear across the fuse during its operation as a function of the applied working voltage E_g .

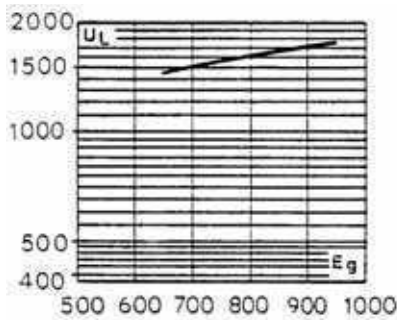

Power Losses

Watts loss at rated current is given in the electrical characteristics. The curve allows the calculation of the power losses at load currents lower than the rated current. The correction factor, K_p , is given as a function of the RMS load current, I_b , in % of the rated current.

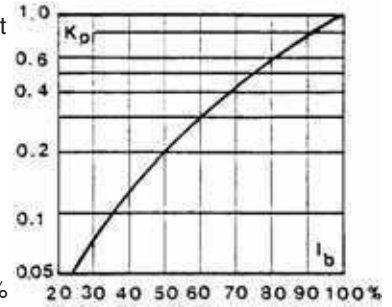

Features and Benefits

- Excellent DC performance
- Low arc voltage and low energy let-through (I^2t)
- Low watts loss
- Superior cycling capability

Typical Applications

- DC common bus
- DC drives
- Power converters/rectifiers
- Reduced voltage starters

Catalog Numbers

Fuse Type	Cat. Numbers -SKNB/140 Type K Indicator	Rated Voltage (Vdc)	Rated Current RMS-Amp	Max Ft (A ² Sec) @ 1000Vdc		Watts Loss (W)		
				L/R = 15ms			L/R = 45ms	
				L/R = 15ms	L/R = 45ms		L/R = 15ms	L/R = 45ms
2SKN / 140	170F8230	1200	160	12000	20000	75.0		
	170F8231		200	20000	35000	85.0		
	170F8232		250	43000	75000	94.0		
	170F8233		315	87000	150000	104.0		
	170F8234		400	180000	310000	120.0		
	170F8235		420	215000	375000	122.0		

Data Sheet: 170K5520

Microswitch: 170H0069, 170H3027 (gold)

Dimensions (mm):

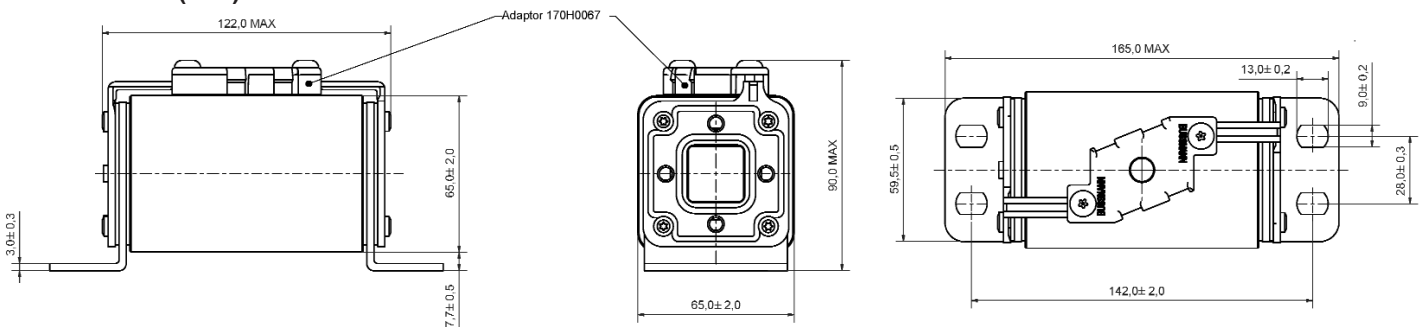

Square Body DC Fuses — 1200Vdc: 160-420A

Square Body DC Fuse — 160-420A: 1200V Time-Current Curve

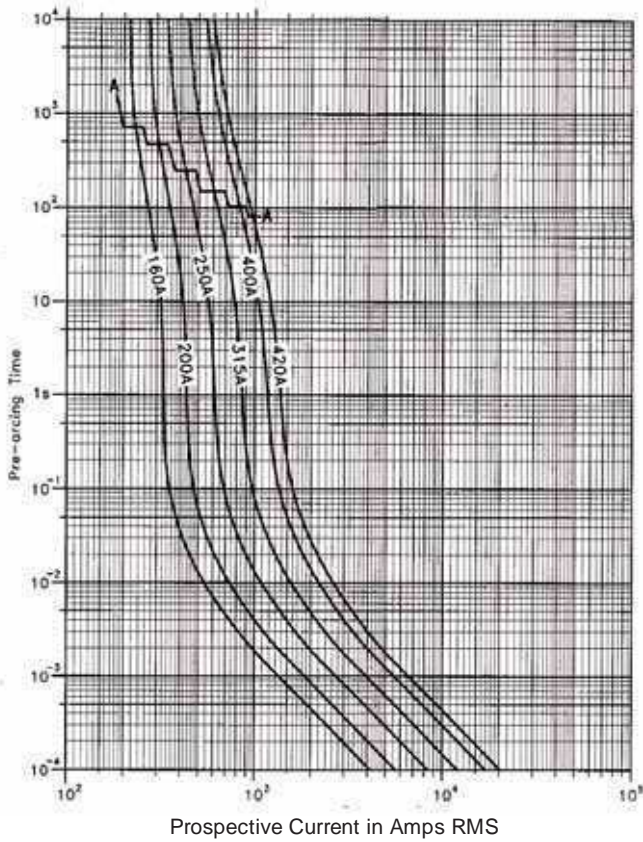

High Speed
Fuses

Data Sheet: Available upon request