

SH-WST-L-10-U

Angle clamp

- Highly flexible versatile mounting system
- All-purpose mounting
- Smooth adjustment
- Robust design

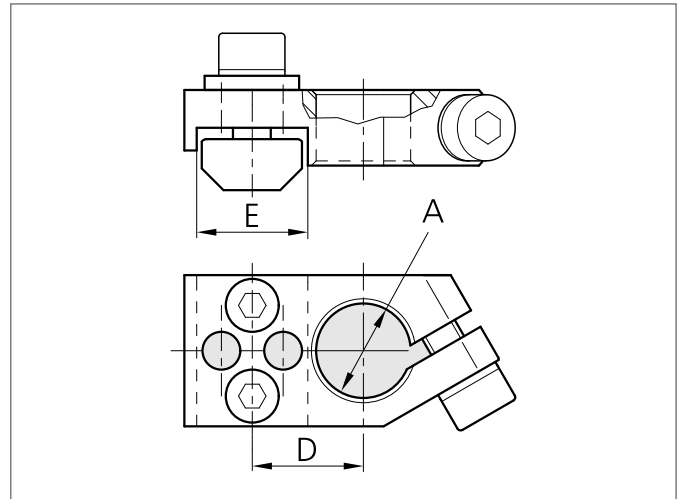
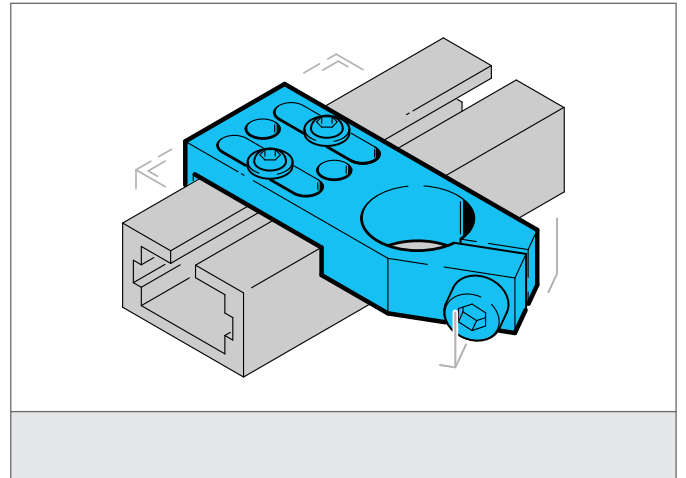

TECHNICAL INFORMATION (typ.)

Size	10 mm (Diameter A) 16 mm (Spacer measure C) 18 mm (Spacer measure E)
For	Clamping pin 10 mm
Casing material	metal
Product series	System holder SH