

# SH-UGU-20-14

## Sensor Holder for Fork light barriers

- Highly flexible versatile mounting system
- All-purpose mounting
- Smooth adjustment
- Robust design

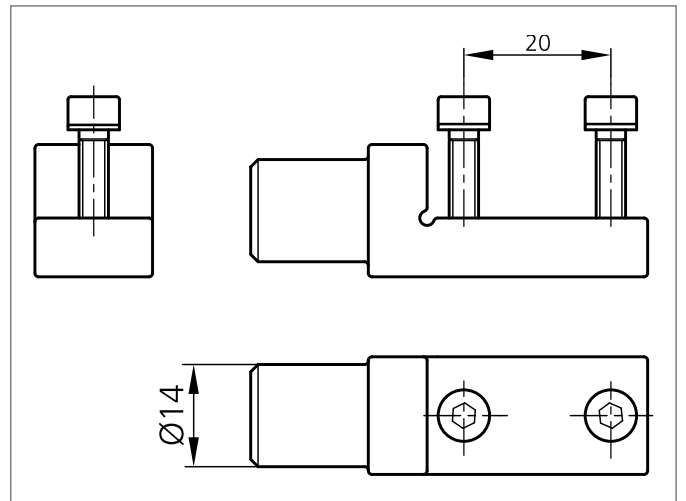
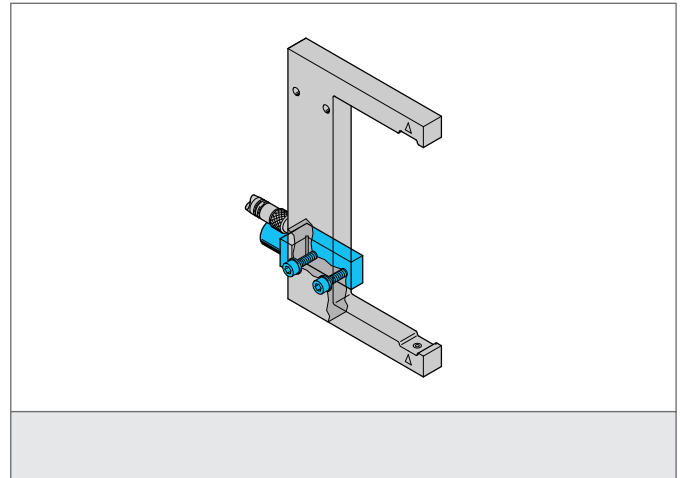

TECHNICAL INFORMATION (typ.)	
Size	+20°C, 24V DC
For	14 mm (A) (Diameter A)
Casing material	Clamping pin 20 mm
Product series	plastics
	System holder HS, System holder SH

