

MB-N-250-K

Machine illumination

- High light intensity thanks to most modern power LEDs
- High colour rendering guarantees safety at the workplace according to DIN EN 12464-1 / EN 12464-1
- Long-life thanks to intelligent thermal management
- Homogeneous wide light field for the optimal machine illumination
- High protection class IP 67
- Trigger input for external control
- Dimmable via PWM signal
- Magnetic Holder Set available as an option
- Adjustable Mounting Bracket available as an option
- Attachable Diffusion filter available as an option

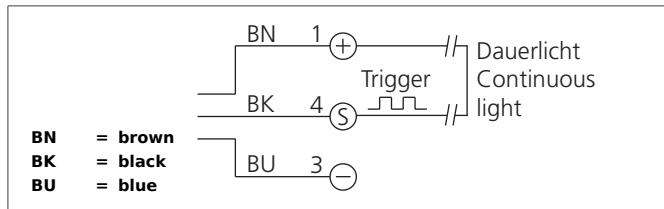

Safety instructions

The Instruments are not to be used for safety applications, in particular applications in which safety of persons depends on proper operation of the instruments.
 These instruments shall exclusively be used by qualified personnel.

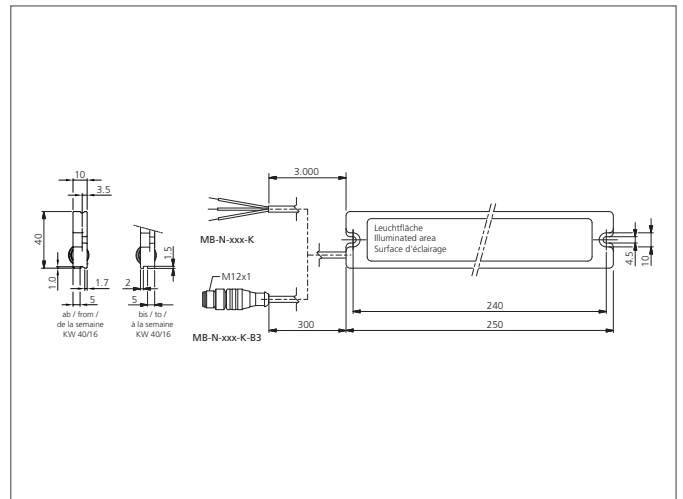

TECHNICAL INFORMATION (typ.)	+20°C, 24V DC
Illuminated area	30 x 220 mm
Light colour	White (5000 K), (LED)
Emission angle	120°
Luminous flux	1.100 lm
Color rendering index CRI	85
Illumination intensity	1.800 Lux (0.5 m / 100%) 530 Lux (1.0 m / 100%)
Service voltage	24 V DC ± 5%, (Supply Class 2)
Internal power consumption	450 mA, (24 V DC)
Trigger input low level	0 ... ≤ 5,0 V
Trigger input high level	≥ 8,0 ... 25,2 V
Power	10,8 W (24 V)
Shock-/vibration load	10 ... 55 Hz / 1,0 mm / 30 g
Inverse polarity protection	Yes
On-delay time (Trig.)	<50 µs
Switch off delay (Trig.)	<50 µs
Ambient temperature	-20 ... +40 °C
Protection class	IP 67
Protection degree	III, operation on protective low voltage
Risk group (DIN EN 62471)	Free group
Casing material	Aluminium black anodized
Material	PU, crystal clear (Window)
Connection	Cable 3 m with flying leads, 3 x 0,34 mm ²

MB-N-250-K
Machine illumination



TECHNICAL INFORMATION (typ.)

+20°C, 24V DC

Weight

260 g