

Quick Start Guide

ID-06 C-Mount Industrial Imager



P/N 83-116801 Rev A

Step 1 — Check Hardware

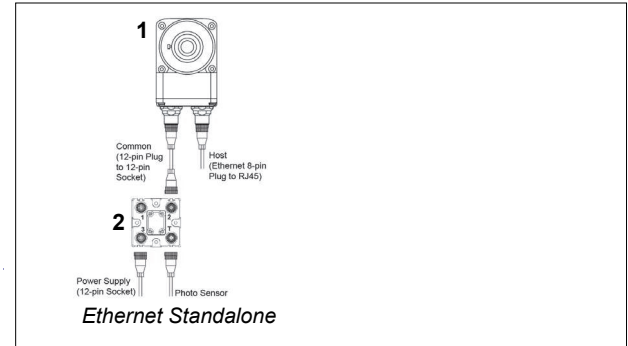

Caution: Be sure that all connections are secure **BEFORE** applying power. Power down **BEFORE** disconnecting any cables.

Item	Description	Part Number
1	ID-06 C-Mount Industrial Imager	ID-06-IXX-00-ES
2	Interface Device	VSID-IB-ES

Note: Additional cordsets and accessories are available in the di-soric Product Catalog.

Step 2 — Connect the System

Important: When connecting cordsets to the ID-06 C-Mount and VSID-IB-ES, align the pins first and then push the connector into place. Do not twist the connectors, as this will bend the pins.

Important: Do not attempt to power more than four imagers with a single power supply in a daisy chain configuration. Add a VSID-IB-ES and one power supply for every four additional imagers in the daisy chain.

RS-232

1. Connect the Serial Communication Cable from "A" on the ID-06 C-Mount to "2" on the VSID-IB-ES.
2. Connect the host cable from "1" on the VSID-IB-ES to the host computer.
3. Connect the photo sensor to "T" on the VSID-IB-ES.
4. Connect the power supply to "3" on the VSID-IB-ES.
5. Plug in the power supply.

Ethernet

1. Connect the Ethernet Cable from "B" on the ID-06 C-Mount to the network.
2. Connect the power supply to "A" on the ID-06 C-Mount.
3. Connect the photo sensor to "T" on the VSID-IB-ES.
4. Plug in the power supply.

Step 3 — Position the Imager

1. Position the imager at a focal distance of one inch or more from a test symbol.
2. Tip the imager relative to the symbol to avoid the glare of direct (specular) reflection. The case parting line should be perpendicular to the plane of the symbol by either pitching the symbol or the imager as shown.
3. Symbols can be rotated (tilted) at any angle; however, for best results symbols should be aligned with the field of view. In the case of linear symbols, aligning the bars in the direction of their movement (ladder orientation) will minimize the chances of blurring and will result in more consistent decodes.

Important: Avoid excessive skew or pitch. Maximum skew is $\pm 30^\circ$; maximum pitch is $\pm 30^\circ$.

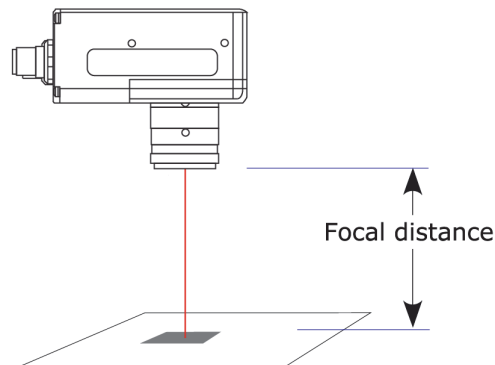

Step 4 — Install di-soric ID

di-soric ID Software can be found on the di-soric USB-Stick that is packaged with the ID-06 C-Mount.

1. Follow the prompts to install di-soric ID from the Tools Drive.
2. Click on the di-soric ID icon to run the program.



Note: di-soric ID can also be installed from the **Download Center** at www.di-soric.com.

Minimum System Requirements

- 233 MHz Pentium processor
- Windows 7 (32-bit or 64-bit), Vista (32-bit or 64-bit), XP, or 2000 operating system
- Internet Explorer 6.0 or higher
- 128 MB RAM or greater
- 80 MB hard drive space
- 800 x 600 minimum 256 color display (1024 x 768 32-bit color recommended)

Refer to the *ID-06 Industrial Imager User's Manual* for detailed information about using di-soric ID to configure the ID-06 C-Mount.

Step 5 — Select Model

When you start di-soric ID, the model menu will appear:

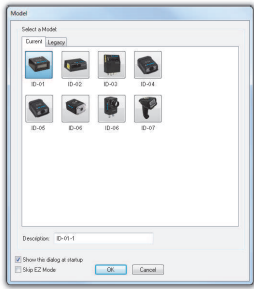

1. Click the button showing the ID-06 C-Mount.
2. Click **OK**.

Note: You can also simply double-click the button showing your imager to make your selection.

3. Click **Yes** when the following dialog appears:

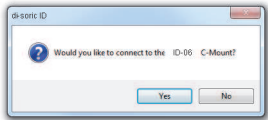

Note: If you need to select another model later, click the **Switch Model** button near the top of the screen or use **Model > New Model** in the menu toolbar.

Step 6 — Connect

To connect using the Connection Wizard:

- Click **Connect** on the menu toolbar, and then select **Connection Wizard**.
- Select **RS-232** or **Ethernet** to activate the appropriate display.
- Configure settings as required by the application, and click **Connect**.

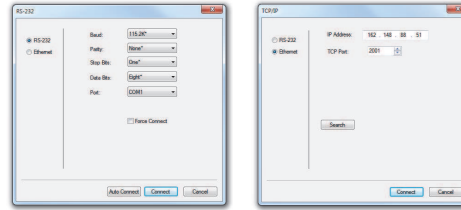

- When a connection is established, the green indicator in the status bar at the bottom right of the screen will be visible:

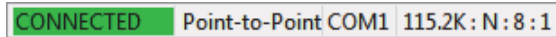

Important: The imager is in **Continuous Read Mode** by default. For best connection results, be sure that no decodable symbols are within the imager's field of view while attempting to connect.

Step 7 — Locate Symbol

Locate by di-soric ID

- In di-soric ID's **EZ Mode**, click the **Locate** button. The symbol in the field of view will appear in the video view beneath the **Locate** and **Calibrate** buttons.
- Center the symbol in the imager's field of view. **Important:** The entire symbol should fall within the field of view (FOV) of the imager. The field of view is what appears in di-soric ID's **Locate/Calibrate** window in **EZ Mode**.
- Click the **Stop** button to end the **Locate** function.



Locate by EZ Button

If you are not connected to a host computer, the EZ Button allows you to locate the symbol in the imager's field of view.

- Hold down the EZ Button for about one second and release when you hear one short beep. The amber **20%** LED will illuminate when the symbol is located.

Note: To end all EZ Button functions, press the EZ Button once and quickly release.

Step 8 — Calibrate

Imager settings can be adjusted automatically for optimum performance by either the EZ Button or by **di-soric ID**.

During the calibration routine, the imager will flash its Read Rate percent LEDs and illumination LEDs while searching camera settings and determining the best configuration for decoding symbol data. If unsuccessful, the imager will emit 5 short beeps and stop searching.

Calibrate by di-soric ID

1. Click the **Calibrate** button.
2. The imager will search camera settings to determine the best configuration for decoding symbol data. A successful calibration will display a green frame around the symbol in di-soric ID, and the following message will appear: "Uploading all reader parameters." After a moment the symbol data will be presented in the field below the image display window.

Calibrate by EZ Button

1. Hold down the EZ Button for about two seconds and release when you hear **two short beeps**. The **20%** and **40%** LEDs will illuminate.
2. The imager will search camera settings to determine the best configuration for decoding symbol data. **Note:** To end all EZ Button functions, press the EZ Button once and quickly release.

Calibrate by Serial Command

Send **<@CAL>** from a terminal program to begin auto-calibration.

Step 9 — Test Read Rate

Read Rate indicates the number of successful decodes per second achieved by the imager.

Test Read Rate by di-soric ID

1. Click the **Test** button to start the **Read Rate** test.



If a symbol has been successfully decoded, its data and related information will be presented in the field below the image display window. While the symbol is being decoded, the Read Rate LEDs will indicate the read rate percentage on the top of the unit.

2. Click the **Stop** button to end the Read Rate test.

Note: Read rate can also be tested using the Read Rate interface in **Utilities**.

Test Read Rate by EZ Button

1. To start the Read Rate test, hold down the EZ Button about three seconds until you hear **three short beeps**. The **20%**, **40%**, and **60%** LEDs on the top of the unit will illuminate. While the symbol is being decoded, the Read Rate LEDs will indicate the read rate percentage on the top of the unit.
2. To end the Read Rate test, press the EZ Button and quickly release.

Test Read Rate by Serial Command

You can also start a test with the **<C>** or **<Cp>** command and end it with the **<J>** command.

Step 10 — Configure and Save

Click the **App Mode** button to make configuration changes.



The following modes are accessible by clicking the buttons at the top of the screen:



- Click the **EZ Mode** button to return to EZ Mode.
- Click the **Autoconnect** button to establish communication.
- Click the **Send/Recv** button to send or receive commands.
- Click the **Switch Model** button to open the model menu.
- Click the **Parameters** button to show the tree controls for Communication, Read Cycle, Symbologies, I/O Parameters, Symbol Quality, Matchcode, and Diagnostics.
- Click the **Setup** button to access the Camera Setup tree and the interfaces for Video, Evaluation, Calibration, Window of Interest (WOI), Configuration Database, Ordered Output, Output Format, and Dynamic Setup.
- Click the **Terminal** button to display decoded symbol data, and to send serial commands to the imager using text or macros.
- Click the **Utilities** button to show the tabbed interfaces for Read Rate, Counters, Device Control, Differences from Default, Master Database, and Firmware.

Saving Options

- **Send, No Save.** Changes will be lost when power is re-applied to the imager.
- **Send and Save.** This activates all changes in current memory and saves to the imager for power-on.