



# VS-05 Smart Camera Guide



Copyright ©2013

All rights reserved. The information contained herein is proprietary and is provided solely for the purpose of allowing customers to operate and/or service di-soric manufactured equipment and is not to be released, reproduced, or used for any other purpose without written permission of di-soric.

Throughout this manual, trademarked names might be used. Rather than place a trademark (™) symbol at every occurrence of a trademarked name, we state herein that we are using the names only in an editorial fashion, and to the benefit of the trademark owner, with no intention of infringement.

## ***Disclaimer***

The information and specifications described in this manual are subject to change without notice.

## ***Latest Manual Version***

For the latest version of this manual, see the Download Center on our web site at:

[www.di-soric.com](http://www.di-soric.com).

## ***Technical Support***

For technical support, e-mail: [service@di-soric.com](mailto:service@di-soric.com).

## ***Warranty and Terms of Sale***

For Standard Warranty information contact:

**di-soric** GmbH & Co. KG

Steinbeisstraße 6

DE-73660 Urbach

Fon: +49 (0) 71 81 / 98 79 - 0

Fax: +49 (0) 71 81 / 98 79 - 179

[info@di-soric.com](mailto:info@di-soric.com)

[www.di-soric.com](http://www.di-soric.com)

---

# Contents

<b>PREFACE</b>	Welcome! v Purpose of This Manual v Manual Conventions v
<b>CHAPTER 1</b>	Introduction 1-1 Product Summary 1-2 Features and Benefits 1-2 Applications 1-3 Package Contents 1-3 VS-05 Smart Camera Models 1-4 Part Number Structure 1-4
<b>CHAPTER 2</b>	System Components 2-1 Hardware Components 2-1 Important Label Information 2-4 Mounting and Wiring the VS-05 Smart Camera 2-5 Status Indicators 2-10 AutoVision Button 2-11 Trigger Debounce 2-12
<b>CHAPTER 3</b>	Optics and Lighting 3-1 Optics 3-2 Illumination 3-3

---

Contents

<b>APPENDIX A</b>	Connector Pinouts A-1 VS-05 Smart Camera Connectors A-2
<b>APPENDIX B</b>	Cable Specifications B-1 61-000208-01 USB Type A to USB Type B Plug Cable B-2 61-000105-01 Host Cable, MS-Connect 210 to Host, Stripped to 9-Pin Socket B-3 VSID-K-25S/9K-2 Communication Cable, DB25 Plug to DB9 Socket B-6 VSID-PS-24V-ES Power Supply, 90-254 VAC, 24VDC, USA/Euro Plug B-8
<b>APPENDIX C</b>	General Specifications C-1 Dimensions C-5 Field of View and Working Distance C-6
<b>APPENDIX D</b>	Serial Commands D-1
<b>APPENDIX E</b>	VS-05 Diagnostic Boot Mode D-1

# Welcome!

## Purpose of This Manual

---

This manual contains detailed information about the VS-05 Smart Camera.

## Manual Conventions

---

The following typographical conventions are used throughout this manual.

- Items emphasizing important information are **bolded**.
- Menu selections, menu items and entries in screen images are indicated as: Run (triggered), Modify..., etc.



---

**CHAPTER 1** Introduction

FIGURE 1-1. VS-05 Smart Camera

---



## Product Summary

---

The VS-05 Smart Camera is designed for reliable vision performance in embedded identification and inspection applications. As the world's smallest fully-integrated vision system, the VS-05's compact size and wide angle optics provide the best performance available for machine vision tasks at close range.

The VS-05 allows OEM design engineers to implement inspection, color matching, symbol decoding, OCR, and more, in a single compact solution. The camera's small form factor allows flexible positioning in tight spaces. The lightweight and durable magnesium alloy case weighs less than 2 ounces.

Pressing the AutoVision button at the back of the VS-05 enables real time dynamic autofocus. When an object is centered in the field of view and the AutoVision button is pressed, the camera automatically adjusts focal distance and sets internal parameters to optimize image captures.

di-soric AutoVision software, designed for use with the VS-05, provides an intuitive interface, step-by-step configuration, and a library of presets that allow easy setup and deployment. For more complex vision applications, the system can be upgraded from AutoVision to VisionScape.

## Features and Benefits

---

- World's smallest fully functional vision system
- USB connectivity
- OEM-ready for easy integration
- Integrated lighting and autofocus lens
- Flexible programming options for custom applications
- AutoVision button for automatic targeting, calibration, and triggering
- Simplified configuration with AutoVision software



---

## Applications

---

- Part presence/absence
- Color detection and matching
- Medical device inspection
- Fiducial location
- Part location/orientation detection
- Packaging
- Robotics
- Auto ID (Data Matrix and other 2D symbologies, 1D, OCR)

---

## Package Contents

---

Before you install AutoVision software and connect your VS-05 Smart Camera, please take a moment to confirm that the following items are available:

- VS-05 Smart Camera — Your package contains one of the available models listed in Table 1–1.
- USB Type A to USB Type B Cable
- AutoVision Software Installation USB Drive

## VS-05 Smart Camera Models

Table 1–1 lists and describes the VS-05 Smart Camera models, including acquisition modes and resolutions.

**TABLE 1–1. VS-05 Smart Camera Models**

<b>Part Number</b>	<b>VS-05 Smart Camera Model</b>
VS-05-BM3-2-US	VS-05 Smart Camera, USB, SD, SXGA, Built-In Light, AutoVision
VS-05E-BM3-2-US	VS-05 Smart Camera, USB, SD, SXGA, Built-In Light, AutoVision + VisionScape
VS-05-BM3-3-US	VS-05 Smart Camera, USB, HD, SXGA, Built-In Light, AutoVision
VS-05E-BM3-3-US	VS-05 Smart Camera, USB, HD, SXGA, Built-In Light, AutoVision + VisionScape
VS-05-BM2-2-US	VS-05 Smart Camera, USB, SD, WVGA, Built-In Light, AutoVision
VS-05E-BM3-2-US	VS-05 Smart Camera, USB, SD, WVGA, Built-In Light, AutoVision + VisionScape
VS-05-BM2-3-US	VS-05 Smart Camera, USB, HD, WVGA, Built-In Light, AutoVision
VS-05E-BM3-3-US	VS-05 Smart Camera, USB, HD, WVGA, Built-In Light, AutoVision + VisionScape

# System Components

This section contains information about system components as well as information to help you connect the VS-05 Smart Camera. Specific information describes connectors, adapters, cables, pinouts, and signals.

Note: There are no user-serviceable parts inside.

## Hardware Components

Table 2-1 lists VS-05 Smart Camera hardware components.

**TABLE 2-1 VS-05 Smart Camera Hardware Components**

Part Number	Description
<b>Upgrade to VisionScape</b>	
VS-UP-AV/VS	Upgrade from AutoVision to verification AM/DPM+VisionScape
VS-UP-AV/VS-OCV	Upgrade from AutoVision to full VisionScape verification AM/DPM+OCV
<b>Power Supply</b>	
VSID-PS-IB	Power Supply, Interface Box, 90-254 VAC, 24VDC, USA/Euro Plug
<b>Communication and I/O Devices and Cables</b>	
VSID-A-24/5V-S	24/5VAdapter
VSID-IB-S	Interface Box, serial

**TABLE 1–1. VS-05 Smart Camera Hardware Components (Continued)**

<b>Part Number</b>	<b>Description</b>
<b>Communication and I/O Devices and Cables</b>	
VSID-A-24/5V-S	Adapter 24V / 5V
VSID-IB-S	Interface Box
VSID-K-25S/9K-2	Communication Cable, DB25 Plug to DB9 Socket, 6'
<b>Mounting Options</b>	
VSID-BW-003	Through-Hole Mount Bracket
VSID-BW-001	Side Mount Bracket
VSID-R90-001	Right-Angle Mirror Kit
VSID-DIF-001	Diffuser Accessory Kit

## Front

Figure 1–1 shows the front of the VS-05 Smart Camera.

**FIGURE 1–1. Front**

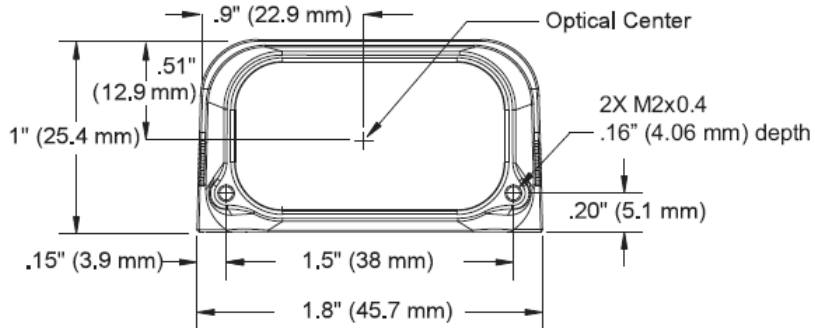

## Base

Figure 2–2 shows the base of the VS-05 Smart Camera.

**FIGURE 1–2. Base**

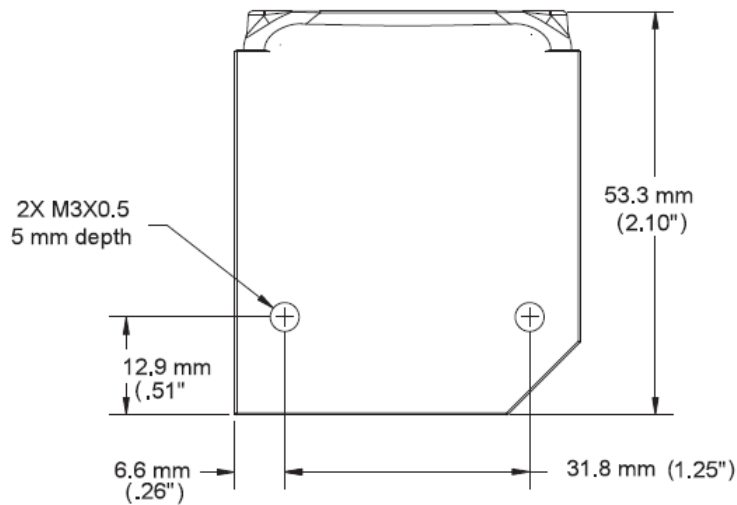

## Back

Figure 2-3 shows the back of the VS-05 Smart Camera.

**FIGURE 1-3. Back**

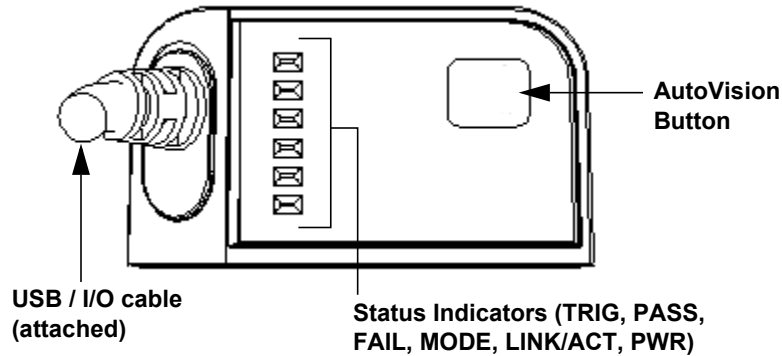

## Important Label Information

Each VS-05 Smart Camera has its own label, which contains important information about that camera.

- P/N — The di-soric part number of your VS-05 Smart Camera.
- S/N — The serial number of your VS-05 Smart Camera.
- MAC — The MAC address of your VS-05 Smart Camera.
- Type — The model type of your VS-05 Smart Camera.

## Mounting and Wiring the VS-05 Smart Camera

- Mount the camera (1) securely in its camera stand (not supplied).
- Make sure the camera (1) is mounted at the optimal distance of 2" to 6".
- Mount the camera (1) as required by the application.
- Connect the USB side of the camera cable (2) to the USB host cable (3).
- Connect the VSID-A-24/5V-S (4) to the VSID-IB-S (5).
- Connect the D-sub side of the camera cable (2) to the VSID-A-24/5V-S (4).
- Connect the trigger (6) to the VSID-IB-S (5).
- Connect the power supply (7) to the VSID-IB-S (5).
- Plug in the power supply (7).

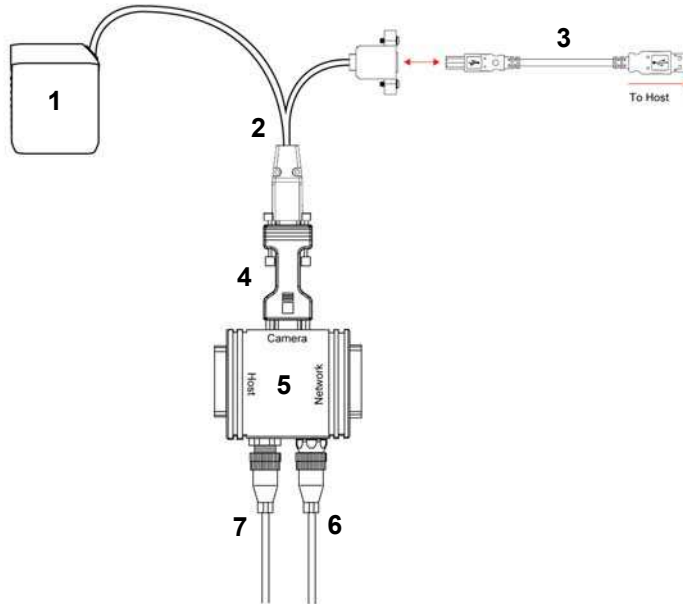

## Direct Input / Output Diagrams

### Trigger Input Example

Trigger, New Master Inputs: 3 to 24V rated, 1mA @ 5VDC

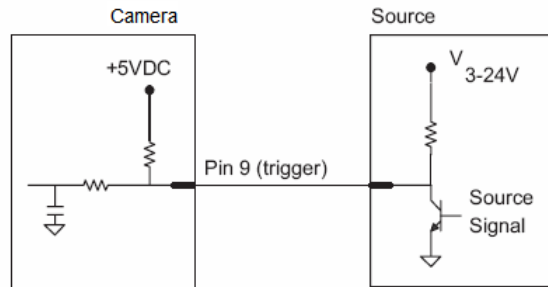

### Output Examples

Outputs (1, 2, 3): 5V TTL compatible, can sink 10mA and source 2mA

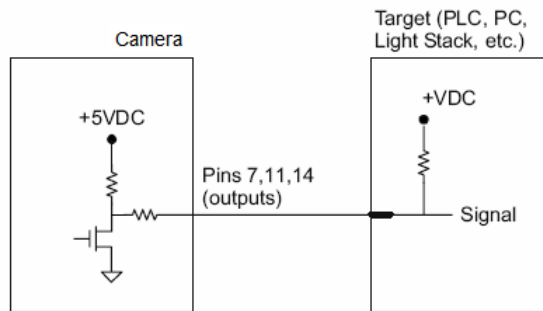
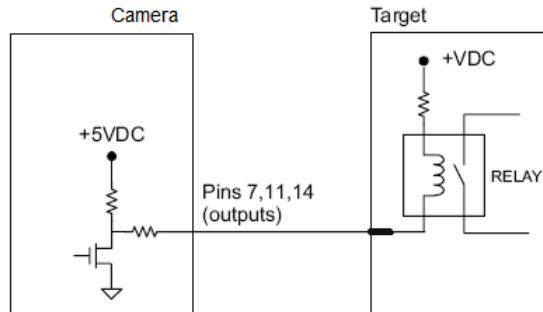



## Isolated Trigger Input with VSID-A-24/5V-S

Trigger input can be fully electrically isolated from an NPN or PNP signal source.

	Minimum	Maximum
$V_{IN-HIGH}/I_{IN-HIGH}$	4.5V/3.0mA	28V/15mA
$V_{IN-LOW}/I_{IN-LOW}$	0V/0mA	2.0V/1mA
Pulse Width <sub>min</sub>	48 $\mu$ s	

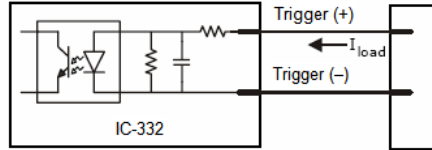

### Input Examples

#### Fully Optoisolated

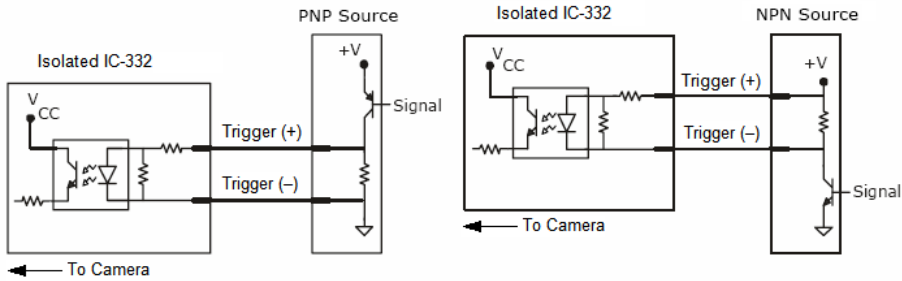

#### Not Optoisolated

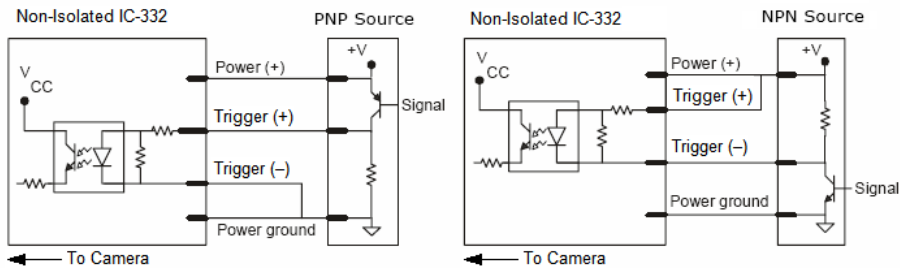

## New Master Input with VSID-A-24/5V-S

The IC-332 converts N/M input to TTL signal through an optoisolator.

Note that the return for N/M is internally grounded, and therefore it is not fully electrically isolated.

	Minimum	Maximum
$V_{IN-HIGH}/I_{IN-HIGH}$	4.5V/3.0mA	28V/15mA
$V_{IN-LOW}/I_{IN-LOW}$	0V/0mA	2.0V/1mA
Pulse Width <sub>min</sub>	48µS	

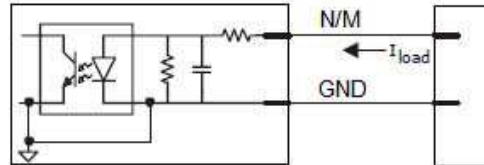

### Example Circuit

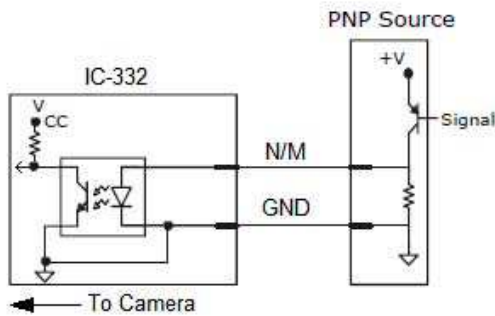

## Power Requirements

Refer to Table 2-3 when determining the power supply requirements for your camera.

**TABLE 1–3. Camera Power Requirements**

<b>Component</b>	<b>5VDC</b>
VS-05 Smart Camera WVGA	5VDC $\pm$ 5%, 200 mV p-p max. ripple, 400 mA @ 5VDC (typ.), 4.0 watts (max.)
VS-05 Smart Camera SXGA	5VDC $\pm$ 5%, 200 mV p-p max. ripple, 465 mA @ 5VDC (typ.), 4.5 watts (max.)

## Status Indicators

The back of the VS-05 Smart Camera has multiple LEDs that indicate different trigger, inspection, camera, communication, and power states.

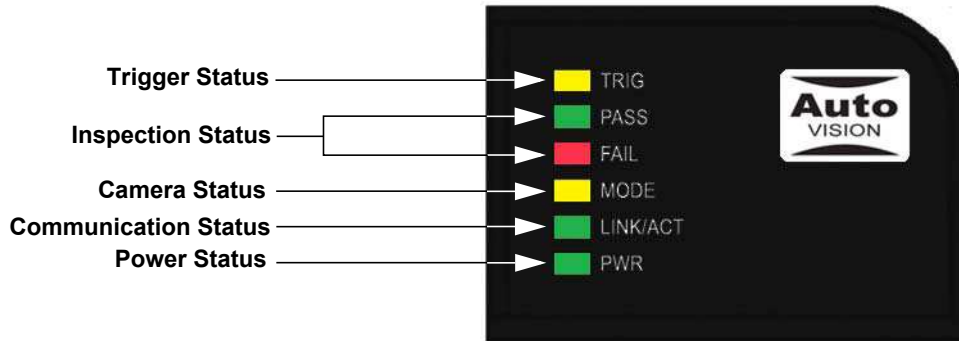

TRIG	On Steady	Continuous Trigger
	Off	Waiting for Trigger Event
	On Flashing	Trigger Event
PASS/FAIL	On	Active State
	Off	Inactive State
MODE	On Steady	Unit Ready
	Off	Unit Not Ready
LINK/ACT	On Steady	Link Established
	Off	No Link/Activity
	On Flashing	Link Established and Activity on Link
PWR	On	Power On
	Off	No Power Applied to Unit

### Additional User Feedback

- Green Flash – A green flash from the front of the unit indicates a Good Read.
- Blue Targeting Pattern – The blue targeting pattern from the front of the unit allows the user to center an object in the camera's field of view.
- Beeper – The beeper is an audible verification that either a Pass or a Fail has occurred.

---

## AutoVision Button

---



The AutoVision Button has three positions, selectable by the length of time the button is held down, and indicated by one, two, or three beeps and LED flashes in succession. It can also be used to send a trigger signal when **Send Trigger** is checked in AutoVision software's **Connect** view. When the trigger functionality is enabled, pushing the AutoVision Button triggers the camera to capture an image.

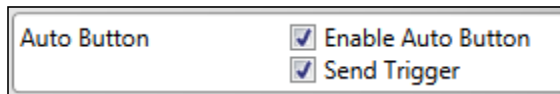

### 1st Position: Blue Targeting Pattern

The first AutoVision Button position turns the targeting system on. This overrides any other targeting modes that have been configured.

### 2nd Position: Auto Calibration

The second AutoVision Button position starts the Auto Calibration process, which selects the appropriate photometry and focus settings for the camera. The selected values are then saved for power-on.

### 3rd Position: Teach

The third AutoVision Button position sets the Match String to the next OCR string or symbol data that is decoded.

## Trigger Debounce

**Trigger Debounce** is the ability of the system to accommodate switching noise on a trigger state change – a common issue with relays that have some intermittent contact while engaging.

Trigger overruns (when the vision system is triggered faster than the device can process) can be avoided by increasing the “debounce” time in the camera definition file located in the C:\di-soric\Vscape\Drivers\CamDefs directory.

The IO Line Debounce High Time and IO Line Debounce Low Time can be added to the file as in the example below. The default debounce time is 1 ms (1,000 µs).

**Note:** Although the value entered for the "IO Line Debounce Time" is in microseconds, it will only be rounded up to a millisecond value. For example, entering the value **1001** will resolve to 2 ms; entering a value of **2800** will resolve to 3 ms.

The min value for "IO Line Debounce Time" is 0, which disables software debounce altogether. The maximum value is 100000 (100 ms).

### Camera Definition File Example

```
// Camera Definition File
// Version: 1.02

Camera Name                VS-05 1280x1024 // Name Displayed in Camdef
Selection Dialog
Digitizer Type             5000                // Number
associated with VS-05 SXGA

Stride                     1280             // Image Width
Rows                      1024            // Image Height
X Offset                   0                // Image X Offset
Y Offset                   0                // Image Y Offset
Bits Per Pixel             8                // Bits that represent Pixel Value
Pixel Type                 0                // Type of Pixel:
MONOCHROME=0, COLOR_RGB=1, COLOR_BGR=2, COLOR_BAYGR8=3, COLOR_BAYRG8=4,
COLOR_BAYGB8=5, COLOR_BAYBG8=6, COLOR_HSI=7
Image Structure            1                // Pixel Organization: Packed=1, TwoPlanes =
2, ThreePlanes = 3
Async Control              1                // Controllable shutter time. Usually
using a pulse width specified in usecs
Usecs Per Frame           62500           // Fastest time to acquire a frame: 16 FPS
// -1 Disables timeout feature

X Offset                   0
Y Offset                   0
// IO Configuration
GPIO Edit Mask             0x0000
GPIO Defaults              0x0001 // 1 General Purpose Input 3 General Purpose
Outputs
GPIO Count                 4
GPIO Inputs                1
GPIO Outputs               3
Sensors                    1                // One input dedicated
to Trigger signal
Strobes                    0
Virtual IO                 2048
IO Line Debounce High Time 2000 //usecs
```

```
IO Line Debounce Low Time 2000 //usecs
// Focus & Photometry Ranges
Gain Dflt          20
Gain Min           0
Gain Max           100           // 0 to 100%
Exp Dflt          4000
Exp Min            66
Exp Max            66667        // 1/15 to 1/15,000
Focus Dflt         400
Focus Min          200
Focus Max          600           // 2 to 6 inches
```





---

# 3

---

## CHAPTER 3

# Optics and Lighting

This section describes the optical and illumination characteristics of the VS-05 Smart Camera.

## Optics

The monochrome and color versions of the VS-05 Smart Camera have a built-in CMOS sensor, available in Standard Density or High Density (2.5 mm).

### WVGA (752 x 480) Field of View

Standard Density			High Density		
Working Distance	Horizontal FOV	Vertical FOV	Working Distance	Horizontal FOV	Vertical FOV
2	1.486	0.949	2	0.663	0.560
3	2.188	1.396	3	0.954	0.824
4	2.889	1.844	4	1.246	1.089
5	3.591	2.292	5	1.537	1.354
6	4.292	2.740	6	1.828	1.619

### SXGA (1280 x 1024) Field of View

Standard Density			High Density		
Working Distance	Horizontal FOV	Vertical FOV	Working Distance	Horizontal FOV	Vertical FOV
2	2.186	1.749	2	1.264	1.011
3	3.182	2.545	3	1.850	1.480
4	4.177	3.342	4	2.436	1.949
5	5.173	4.138	5	3.022	2.418
6	6.168	4.935	6	3.608	2.886

---

## Illumination

---

The VS-05 Smart Camera has built-in lighting (red LEDs). The LEDs can be configured to operate in multiple modes – Continuous, Strobe, and Off.

### Lighting Examples

The following lighting examples were captured with a Standard Density VS-05.

**FIGURE 3–1. Semi-Specular Surface (Fine Matte Metal Ruler) at 2", 90°**

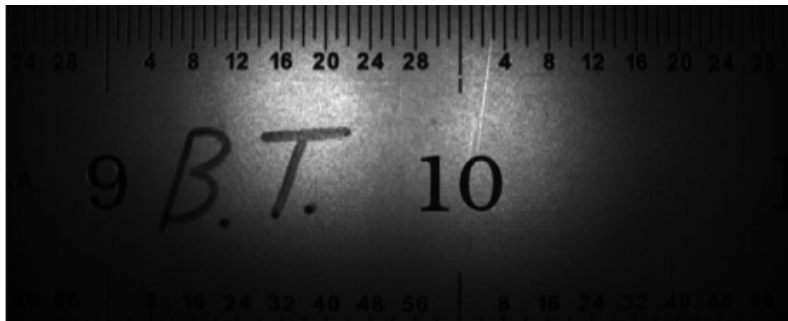

**FIGURE 3–2. Off-Axis – Semi-Specular Surface (Fine Matte Metal Ruler) at 2", 90°**



## Machine Vision Lighting Principles

Proper lighting is critical to the success of a machine vision application. The VS-05 features integrated lighting (built-in red LEDs @ 617nm). Depending on the requirements of your application, you may also need to add external lighting from the machine vision lighting products of di-soric.

Consider the following when setting up your application:

- Is the surface of the object flat, slightly bumpy, or very bumpy?
- Is the surface matte or shiny?
- Is the object curved or flat?
- What is the color of the object or area being inspected?
- Is the object moving or stationary?

Machine vision lighting should maximize contrast of the areas or features being inspected while minimizing the contrast of everything else.



**Before correct lighting**

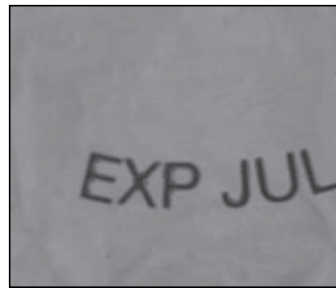

**After correct lighting**

If you need more information about solid solutions with a VS-05 camera and corresponding Lightings, get in contact with di-soric.

---

# A

---

## APPENDIX A

# Connector Pinouts

This section contains information about the VS-05 Smart Camera's USB and I/O connectors.

## VS-05 Smart Camera Connectors

### USB and I/O Cable

Figure A-1 shows the location of the USB and I/O cable.

**FIGURE A-1. USB and I/O Cable**

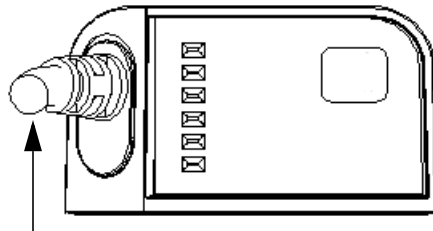

**USB / I/O Cable (attached)**

TABLE A-1. and TABLE A-2. describe the USB and I/O cable signals.

**TABLE A-1. USB and I/O Cable Pin Assignments (15-pin D-sub Socket)**

Pin	Host RS-232	In/Out
1	Power +5VDC	In
2	TxD	Out
3	RxD	In
4	Power/Signal Ground	
5	NC	
6	NC	Out
7	Output 1 TTL (Can sink 10mA and souce 10mA)	Out
8	Default configuration (activated by connecting pin 8 to ground pin 4)	In
9	Trigger	In
10	NC	In
11	Output 3 TTL (Can sink 10mA and souce 10mA)	Out
12	Input 1 (NPN)	In
13	Chassis ground (Connects chassis body to earth ground only. Do not use as power or signal return.)	
14	Output 2 TTL (Can sink 10mA and souce 10mA)	Out
15	NC	

Figure A-2 shows the pinout of the 15-pin D-sub Socket.

**FIGURE A-2. 15-pin D-sub Socket**

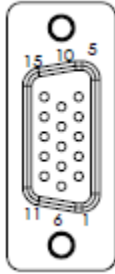
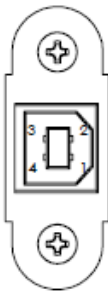

**TABLE A-2. USB and I/O Cable Pin Assignments (USB Type B Socket)**

Pin	Function
1	Vbus (5V)
2	D-
3	D+
4	Ground

Figure A-3 shows the pinout of the USB Type B Socket.

**FIGURE A-3. USB Type B Socket**







## Cable Specifications

This section contains information about VS-05 Smart Camera cables.

Note: Cable specifications are published for information only. di-soric does not guarantee the performance or quality of cables provided by other suppliers.

**TABLE B-1. Cable Part Numbers and Descriptions**

Part Number	Description
VSID-K-25S/9K-2	Communication Cable, DB25 Plug to DB9 Socket, 6'
VSID-K-S/U	Konverter RS 232/USB
VSID-PS-IB	Power Supply, 90-254 VAC, 24VDC, USA/Euro Plug

## 61-000208-01 USB Type A to USB Type B Plug Cable

The USB Type A to USB Type B Plug Cable is a double-ended shielded ferrite bead USB cable.

Figure B-1 shows the USB Type A to USB Type B Plug Cable.

**FIGURE B-1. USB Type A to USB Type B Plug Cable**

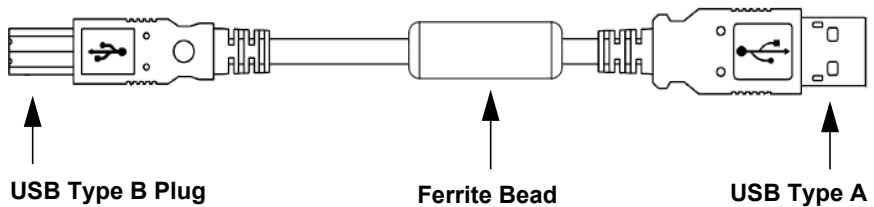

## VS-05 USB / I/O Cable (Attached)

The VS-05 USB / I/O Cable is attached to the camera. It is a shielded cable in a “pigtail” configuration with a USB Type B socket and an RS-232 15-pin D-sub socket.

Figure B-3 shows the USB / I/O Cable.

**FIGURE B-2. VS-05 USB / I/O Cable (Attached)**

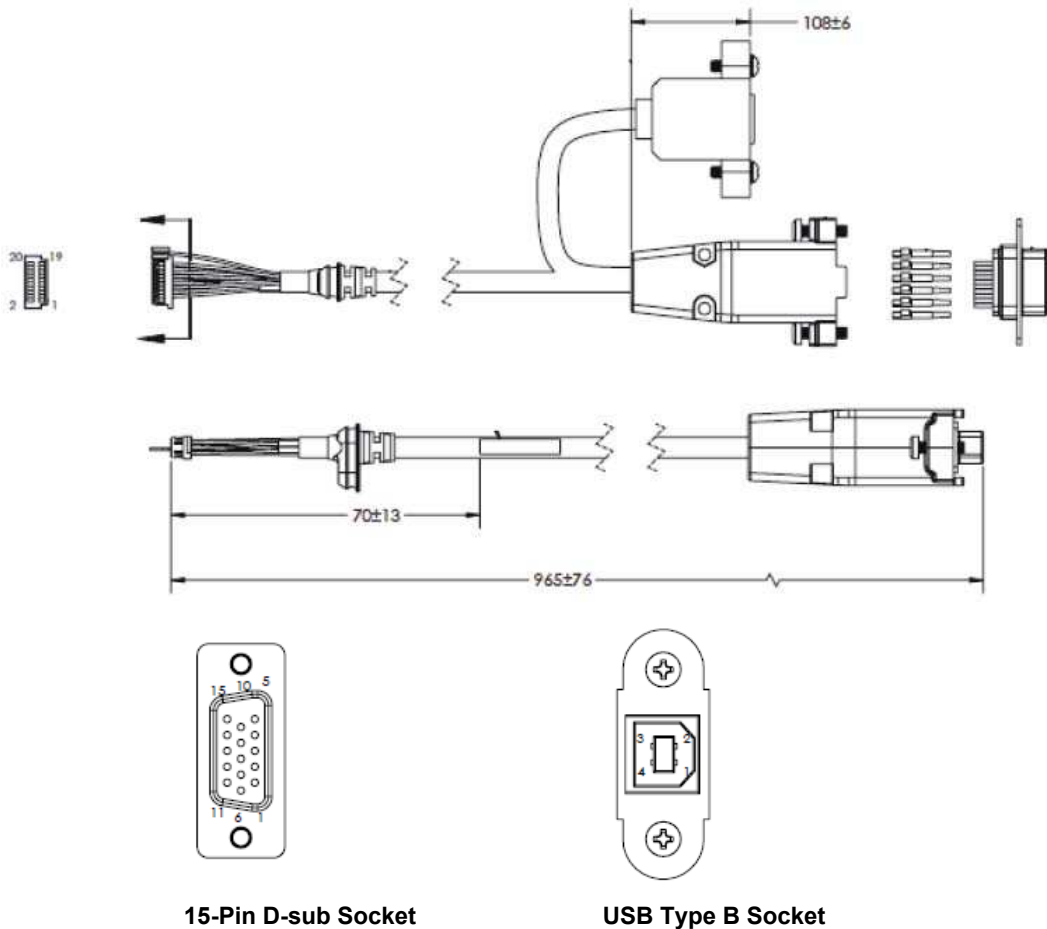

Tables B-3 and B-4 describe the signals for VS-05 USB / I/O Cable.

**TABLE B-2. USB and I/O Cable Pin Assignments (15-pin D-sub Socket)**

Pin	Host RS-232	In/Out
1	Power +5VDC	In
2	TxD	Out
3	RxD	In
4	Power/Signal Ground	
5	NC	
6	NC	Out
7	Output 1 TTL (Can sink 10mA and souce 10mA)	Out
8	Default configuration (activated by connecting pin 8 to ground pin 4)	In
9	Trigger	In
10	NC	In
11	Output 3 TTL (Can sink 10mA and souce 10mA)	Out
12	Input 1 (NPN)	In
13	Chassis ground (Connects chassis body to earth ground only. Do not use as power or signal return.)	
14	Output 2 TTL (Can sink 10mA and souce 10mA)	Out
15	NC	

**TABLE B-3. USB and I/O Cable Pin Assignments (USB Type B Socket)**

Pin	Function
1	Vbus (5V)
2	D-
3	D+
4	Ground

## Communication Cable, DB25 Plug to DB9 Socket

The Communication Cable, DB25 Plug to DB9 Socket is a shielded RS-232 cable ending in a 25-pin D-sub plug and a 9-pin D-sub socket.

Figure B-4 shows the Communication Cable, DB25 Plug to DB9 Socket.

**FIGURE B-3. Communication Cable, DB25 Plug to DB9 Socket**

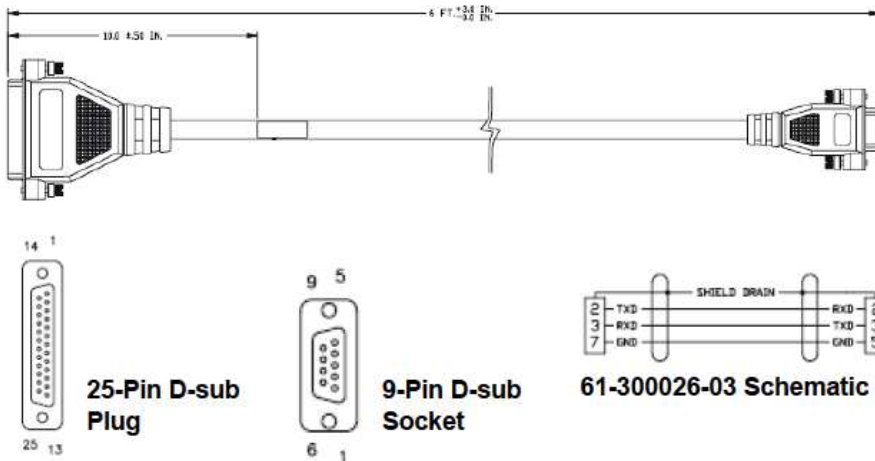

Table B-5 describes the signals for the Communication Cable, DB25 Plug.

**TABLE B-4. Communication Cable, DB25 Plug Pin Assignments**

Pin	Function
2	TxD
3	RxD
7	Ground

Table B-6 describes the signals for the Communication Cable, DB9 Socket.

**TABLE B-5. Communication Cable, DB9 Socket Pin Assignments**

Pin	Function
2	RxD
3	TxD
5	Ground

## Power Supply, 90-254 VAC, +5VDC

The Power Supply, 90-254 VAC, +5VDC ends in a 3-pin Micro-Change connector.

Figure B-5 shows the Power Supply, 90-254 VAC, +5VDC.

**FIGURE B-4. Power Supply, 90-254 VAC, +5VDC**

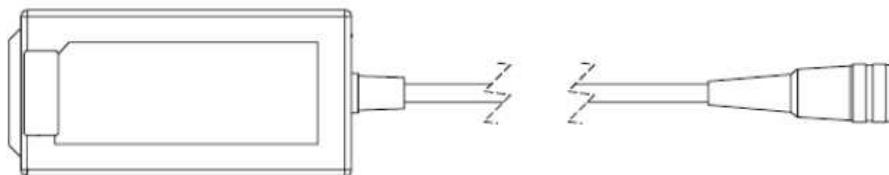

Table B-7 describes the signals for the Power Supply, +5VDC.

**TABLE B-6. Power Supply, +5VDC Pin Assignments**

Pin	Function
1	Ground (Black)
2	Shield (Bare)
3	+5VDC (White)

## Power Supply, 24VDC, USA/Euro Plug

The Power Supply, 24VDC, USA/Euro Plug ends in a 3-pin Micro-Change connector and comes with both a U.S. and Euro plug.

Figure B-6 shows the Power Supply, 24VDC, USA/Euro Plug.

**FIGURE B-5. Power Supply, 24VDC, USA/Euro Plug**

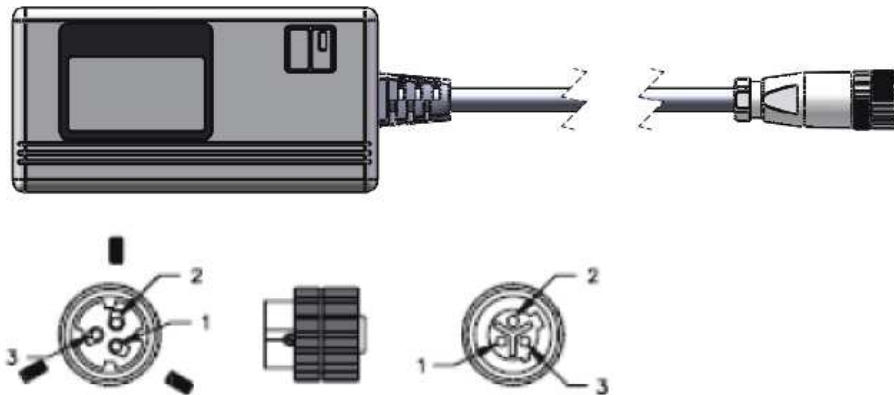

### 3-Pin Micro-Change Connector

Table B-8 describes the signals for the Power Supply, 24VDC, USA/Euro Plug.

**TABLE B-7. Power Supply, 24VDC, USA/Euro Plug Pin Assignments**

Pin	Function
1	Ground (Black)
2	Shield (Bare)
3	+24VDC (White)





APPENDIX C

# General Specifications

This section contains specifications and dimensions for the VS-05 Smart Camera.

**TABLE A-1. General Specifications**

Part Number	VS-05-BM3-2-US	VS-05E-BM3-2-US	VS-05-BM3-3-US	VS-05E-BM3-3-US
Sensor	SXGA (1280 x 1024) CMOS, up to 15 fps			
Sensor Format	1/2"			
Sensor Color	Monochrome			
Height	1" (25.4 mm)			
Width	1.80" (45.7 mm)			
Depth	2.10" (53.3 mm)			
Weight	2 oz. (57 g)			
Power	5VDC +/- 5%, 200 mV p-p max. ripple, 465 mA @ 5VDC (typ.), 4.5 watts (max.)			
Connector	3 ft. cable terminated with high density 15-pin D-sub socket connector and USB Type B socket connector			
Lens Type	Fixed Lens			
Comm.	RS-232, USB 1.1 (Ethernet emulation mode driver available)			
Illumination	Red @ 617nm			
Indicators	<b>LEDs:</b> Trigger, Pass, Fail, Mode, Power, Link/Act; <b>Green Flash:</b> Pass; <b>Blue V:</b> Target			
I/O	<b>Trigger Input:</b> 5 to 28VDC rated (.16 mA); <b>Input 1:</b> 5 to 28VDC rated (.16 mA); <b>Outputs (1, 2, 3):</b> 5V TTL compatible, can sink 10 mA and source 10 mA; <b>Optional I/O:</b> Optoisolated (with VSID-A-24/5V-S accessory)			
Image Acquisition	Progressive scan, square pixel			
Focal Range	2 to 6" (50.8 mm to 152.4 mm – autofocus)			
Shutter	Software-adjustable, 10 μs to 16.7 ms; Rolling Shutter			
Pixel Size	5.2 um x 5.2 um			
Operating Temperature	0° to 40° C (32° to 104° F)			
Storage Temperature	-50° to 75° C (-58° to 167° F)			
Humidity	Up to 90% (non-condensing)			
Enclosure	IP54 (category 2)			
Compliance	<b>FCC, UL/cUL, CE (General Immunity for Light Industry: EN 55024 ITE Immunity Standard; Radiated and Conducted Emissions of ITE Equipment: EN 55022 ITE Disturbances), CB, RoHS/WEEE</b>			

## Dimensions

Front

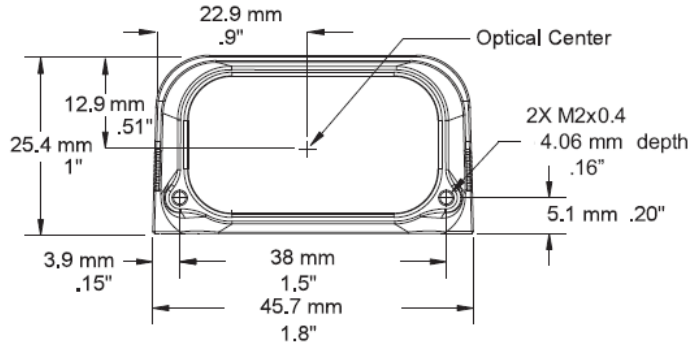

Base

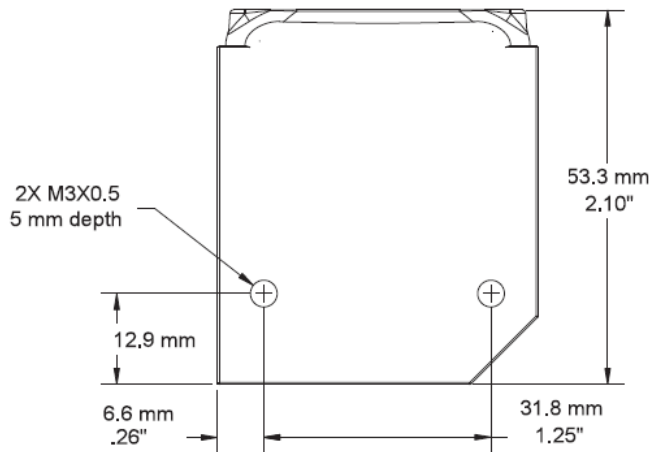

**Note:** Nominal dimensions shown. Typical tolerances apply.

## Field of View and Working Distance

### SXGA

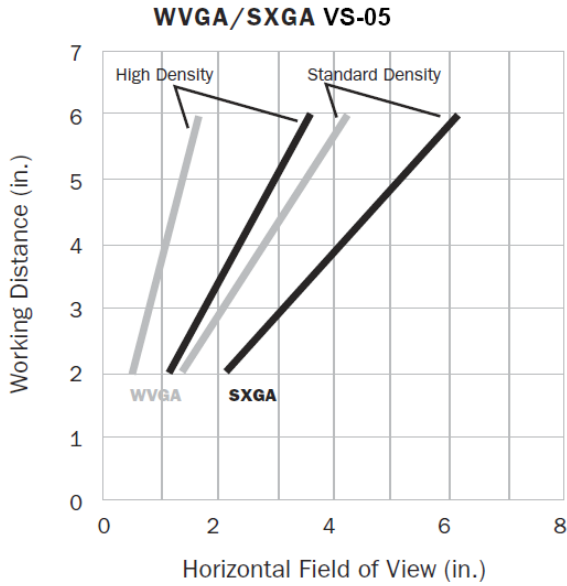



# Serial Commands

This section provides descriptions of the serial commands that can be sent to the camera via TCP (Telnet) port, AutoVision Terminal, or HyperTerminal.

## **SET {tagname}{value}**

Sets value of a global tag.

The tagname must correspond to one of the supported tags within the device.

The value can contain spaces.

The command is terminated by a carriage return and/or line feed character.

The value can be a list of comma-separated items to set a sequence of tags:

Send **SET int1 1, 2, 3** to set int1 = 1, int2 = 2, int3 = 3.

The AVP service allows setting of step and datum information from the job tree using forward slash '/' in the symbolic name path. **SET avp/insp1/snapshot1/acq1/gain 2.0** paths are not case-sensitive and do not need to be fully qualified if unique.

**SET avp/acq1/gain 2.0** will set the same gain value if there is only one acquire.

Control tags in the AVP service such as **START**, **STOP**, and **TRIGGER** act as momentary switches. **SET avp.start 1** is equivalent to the **ONLINE** command. **avp.start** will reset immediately and always read as **0**.

**Success Return:** On success will return **!OK** followed by an echo of the command. For example:

**!OK SET matchstring1 ABCD**

**Fail Return:** On failure will return **!ERROR** followed by the reason for the failure. For example:

**!ERROR Tag matchstring66 not found**

## **GET {tagname}**

Gets value of a global tag.

The tagname must correspond to one of the supported tags within the device.

---

The command is terminated by a carriage return and/or line feed character.

Include an index to get a single value from an array such as **GET int1**. If the index is omitted, the full array of values will be returned in a comma-separated list of values.

Send **Get {tagname}** to get the value of a tag within the global data service. To get the value of a tag within another service, prefix the tagname with the service name. For example, a **GET {service.tagname}** command such as **GET eip.input** for the EIP input assembly.

The AVP service allows retrieval of step and datum information from the job tree using forward slash '/' in the symbolic name path. **GET avp/insp1/snapshot1/status** paths are not case-sensitive and do not need to be fully qualified if unique.

**GET avp/snapshot1/status** will return the same result if there is only one inspection.

When issued against a step, **GET avp/snapshot1** will return the values for all datums.

**Success Return:** On success will return the value stored in the tag. For example:

**ABCD**

**Fail Return:** On failure will return **!ERROR** followed by the reason for the failure. For example:

**!ERROR Tag matchstring66 not found**

## **INFO {service.tagname or service}**

Gets information about a tag or service.

INFO with no arguments gets a list of services.

INFO {service} gets a list of tags in that service.

INFO {service.tagname} gets attributes of the tag as well as a list of subtags.

The AVP service allows retrieval of step and datum information from the job tree using forward slash '/' in the symbolic name path.

**INFO avp/insp1/snapshot1/status** paths are not case-sensitive and do not need to be fully qualified if unique.

**INFO avp/snapshot1/status** will return the same result if there is only one inspection.

When issued against a step, **INFO avp/snapshot1** returns properties of the step, a list of child datums, and a list of child steps. Child steps are indicated by a trailing forward slash.

## **GETIMAGE {-transfer=ymodem} {-type=failed}{-format=[jpg|png]} {-quality=n} {-inspection=n} {woi=l,t,r,b}**

Initiates serial transfer of inspection image.

**-transfer=ymodem** is not currently optional - only Ymodem protocol is supported.

**-type=failed** to retrieve the last failed image. If omitted, the current image is returned.

**-format=[jpg|png]** specifies the format of the image. If omitted, the image format is JPG.

**-quality=n** specifies a JPG compression quality of *n* less than or equal to 100. The default quality is **80** if not specified.

**-inspection=n** specifies the inspection from which to retrieve an image. The image will be from the first snapshot within that inspection. If not specified, the image will be from the first inspection that does contain a snapshot.

**woi=left,top,right,bottom** specifies a rectangular area of the image to be included in the output image. If omitted, the full image buffer is returned.

## **ONLINE**

Starts all inspections.



---

## OFFLINE

Stops all inspections.

## TRIGGER {inspection index}

Triggers inspection. If {inspection index} is omitted, inspection 1 is triggered.

## VT (Virtual Trigger) Command

Triggers an inspection by pulsing a Virtual I/O point. For example:

### VT 1

will return pulse **VIO1**. The inspection will run if it is configured to use **VIO 1** as a trigger.

### Syntax: VT [VIO Index]

- If specified, the VIO index must be in the allowed range for Virtual I/O points within VisionScape. The virtual I/O line will be set high then low.
- If VIO Index is not specified, VIO1 is assumed

**Success Return:** Nothing is echoed on success of the VT command.

**Fail Return:** Return **!ERROR** followed by the reason for the failure. For example:

**!ERROR No such trigger**

## JOBSAVE [-slot=]n

Save job to slot *n*.

## JOBLOAD [-slot=n][-r]

Load job from slot *n*.

-r = Start inspections.

## **JOBDELETE [-slot=n]**

Delete job in slot *n*.

## **JOBINFO [[-slot=n][-v]**

Get job summary or info about slot *n*.

-v = Verbose. This option shows the amount of space that would be freed if the job were deleted. It also lists the total disk space and free disk space.

## **JOBBOOT {-slot=n}**

Set bootup job slot *n*.

## **JOBDOWNLOAD [-transfer=]{YMODEM}**

Download .avz job packaged via transfer method.

## **JOBDELETE -all**

Delete all jobs in job slots.

**Important:** Does not delete the current job loaded in camera memory.

## **GET SYSTEM.JOBSLOT**

Retrieve the slot of the current job. Note that the current job in the camera can be loaded from a job slot or the PC. If it isn't loaded from a job slot then this command will return -1.

---

**APPENDIX E**      **Diagnostic Boot Mode**

This section describes the VS-05's Diagnostic Boot Mode.

## Diagnostic Boot Mode

The VS-05 supports a special boot mode used for diagnostics and recovery. There are two ways in which the camera can be put into this mode:

1. This method requires an Ethernet connection between the host PC and VS-05. Power-on the unit and hold down the AutoVision button until the green flash illuminates once. The unit is now configured for IP address 192.168.188.10 with subnet mask 255.255.255.0. Establish a telnet connection between the host PC and VS-05. The [SAFE-KERNEL] prompt is displayed.
2. This method requires a serial connection between the host PC running a terminal emulator and VS-05 camera. Power-on the unit and hold down the Tab key for several seconds. The unit will boot to a [SAFE-KERNEL] prompt with communication settings of 115200, N, 8, 1 (baud, parity, data bits, stop bits).

Once the unit is booted, there are many possible actions the user can take. However, the most useful actions are listed below.

In rare situations, the boot job executed at camera startup can cause unexpected behavior. If this is the suspected case, it is possible to disable loading and running of the boot job at startup using the following command.

**[SAFE-KERNEL]** BP\_UpdateStartupOptions(0, 0)

Note that the loading and running of the boot job is automatically re-enabled the next time a job is saved to camera flash from AutoVision or FrontRunner.

At boot time, the system configures itself using a set of information known as boot parameters. To obtain a list of the current configuration's boot parameters, issue the following command.

**[SAFE-KERNEL]** BP\_Dump()

Should your device need to be configured with different IP information, follow the example below and substitute the appropriate settings for IP address, subnet mask, and gateway address, respectively.

**[SAFE-KERNEL]** BP\_UpdateIP("192.168.188.10", "255.255.255.0", "192.168.188.1")

---

It is possible to configure the system to acquire its IP address via DHCP or to use a static IP address. Issue the following command with a '0' for static IP or a '1' for DHCP.

**[SAFE-KERNEL]** BP\_UpdateDHCP(0)

