

Insulated Enclosure KO 4300stS

removeable terminal blocks with screw connections
for machine soldering technology

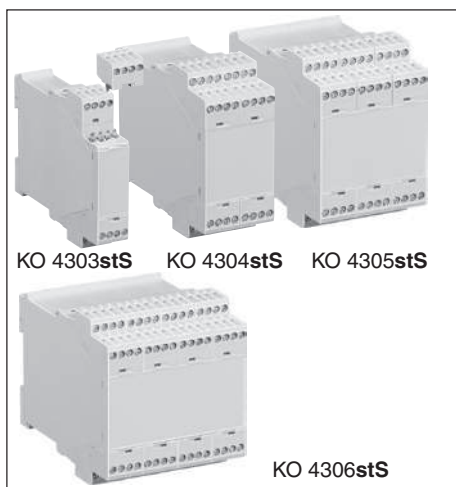

Approvals and Markings



Your Advantages

- modular, flexible
- various connection technologies
- distinctive design
- individual customisation

Features

- Width 22,5 / 45 / 67,5 / 90 mm
- max. 16 / 32 / 48 / 64 terminals
- Large, variable front plate surface
- Large cross section of connections possible (e.g. 2 x 1.5 mm² with stranded ferruled)
- Max. current carrying capacity 16 A
- Machine soldered terminal block, use of heat-resistant plastic means no cover for the terminal block facing the soldering bath is required
- Large plus-minus screws enable high tightening torques
- High-voltage test complying with IEC 60 439-1
- Printed circuit board density t = 1.5 mm and 1 mm possible
- More option possible, see "Other options"

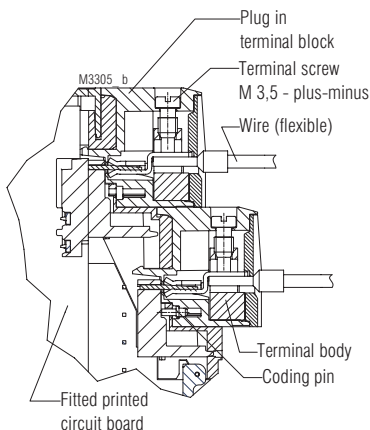

Twin-level box-terminal

Technical Data

Width [mm]	Depth [mm]	Order references	Article-No.:	Version
22,5	118	KO4303stS.	0055673	Standard
	97	KO4323stS.	0066646	UL
			0055684	Standard
45	118	KO4304stS.	0055674	Standard
	97	KO4324stS.	0066648	UL
			0055685	Standard
67,5	118	KO4305stS.	0055675	Standard
	97	KO4325stS.	0066650	UL
			0055686	Standard
90	118	KO4306stS.	0055676	Standard
	97	KO4326stS.	0066652	UL
			0055687	Standard
			0066653	UL

Enclosure material:

Standard version:

PC-GF, light gray RAL 7035

(base plug in terminal block, side part and front plate)
PA4/6, natur (terminal block)

Version UL

as well as standard, but plug in terminal block and side part in PA66/6, light gray RAL 7035

Temperature stability	PC	PA66/6	PA4/6
complying with UL 746 B:	125 °C	120 °C	120 °C
complying with Vicat ISO 306	Meth. B: 148 °C	230 °C	290 °C
compl. with ISO 75-2	Meth. A: 138 °C Meth. B: 144 °C	225 °C 235 °C	290 °C 290 °C

Max. permitted power dissipation: see diagrams

Specific thermal resistance:

KO 4303stS; 04stS; 05stS: R_{th} = 6.5 K/W; 5.5 K/W; 4.2 K/W

KO 4323stS; 24stS; 25stS: R_{th} = 9.0 K/W; 6.5 K/W; 5.4 K/W

Flame retardancy compl. with UL 94: V-0

Number of terminals

KO 4303stS, KO 4323stS: 16
 KO 4304stS, KO 4324stS: 32
 KO 4305stS, KO 4325stS: 48
 KO 4306stS, KO 4326stS: 64 } less, on request

Terminal material:

steel strip, tin-plated

Max. cross section for connection

	AWG	20 - 12	20 - 12
solid / stranded:	mm ²	1 x 0.5 ... 4 / 0.5 ... 4	2 x 0.5 ... 2.5 / 0.5 ... 2.5
stranded ferruled, without or with plastic sleeve	mm ²	1 x 0.5 ... 2.5	2 x 0.5 ... 1.5
stranded twin ferruled and plastic sleeve	mm ²	1 x 0.5 ... 1.5	
stripping length/length of ferrule	mm	8	8

Wire fastening:

Captive plus-minus-terminal screws M3.5 with self raising terminal box

Max. contact resistance

to printed circuit board: 10 m Ω

Max. current carrying capacity:

16 A; US: 15 A; CN: 12 A

Inner connection:

Terminal block can be machine soldered; **use of heat-resistant plastic means no cover for the terminal block facing the soldering bath is required**

Enclosure fastener:

Snap-on fastener on top hat rail IEC/EN 60 715

Creepage resistance:

Standard version:

CTI 175 ≙ insulating material III a IEC 60 664-1

CTI 250 - 400 ≙ insulating material III a IEC 60 664-1

UL version:

same as standard, but the plug in terminal block and side-part CTI 550 ≙ insulating material II IEC 60 664-1

Technical Data

Air gap and creepage distance:	≥ 4,0 mm	IEC 60 664-1
Type of protection		
Enclosure:	IP 40	IEC 60 529
Terminal strip:	IP 20	IEC 60 529
	contact protection complies with VBG 4	
Print area:		
KO 4303stS, KO 4323stS:	20.5 x 43.6 mm	
KO 4304stS, KO 4324stS:	43 x 43.6 mm	
KO 4305stS, KO 4325stS:	65 x 43.6 mm	
KO 4306stS, KO 4326stS:	88 x 43.6 mm	
Printed circuit board:	See printed circuit board design	
Printed circuit board holder:	Guide ribs in base	
Other options:	<ul style="list-style-type: none">- Variable equipping level- With ground terminal to top hat rail- Side openings, e. g. for bus connection or ventilation slots- Openings in base, e. g. for bus connection to top hat rail- Variable front plate, optionally with:<ul style="list-style-type: none">* flap cover* openings, depending on customer specification* combination of 22.5 and 45 mm (width)	

**More informationen
see brochure G23**

Dimensions

KO 430_stS

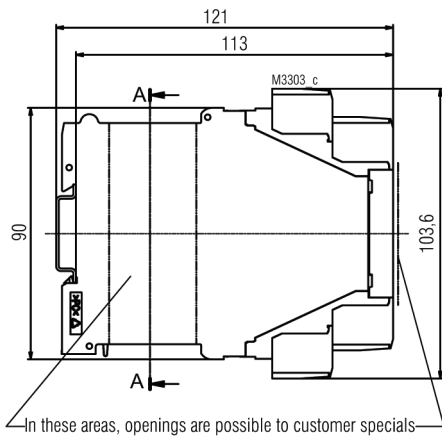

KO 432_stS

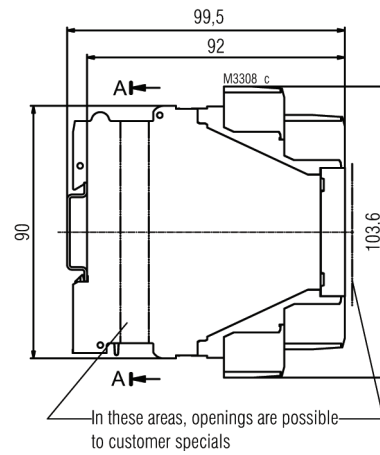

Printed circuit board configuration KO 4303stS / KO 4323stS

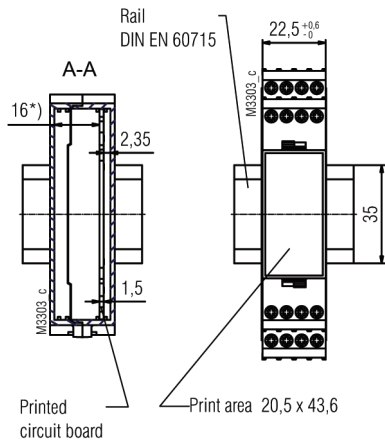

*) 16,5 with printed circuit board thickness $t = 1$ mm

Printed circuit board configuration KO 4304stS / KO 4324stS

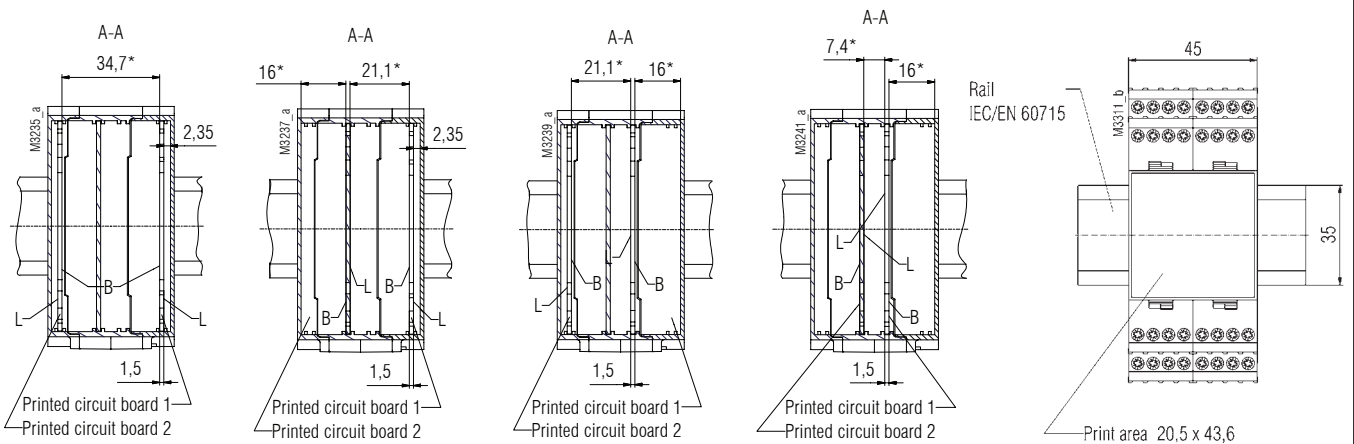

Dimensions

Printed circuit board configuration KO 4305stS / KO 4325stS

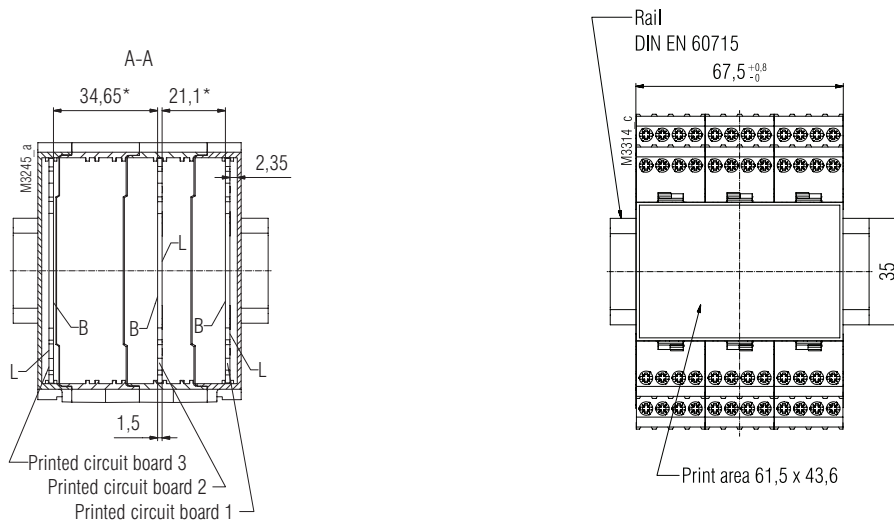

Printed circuit board configuration KO 4306stS / KO 4326stS

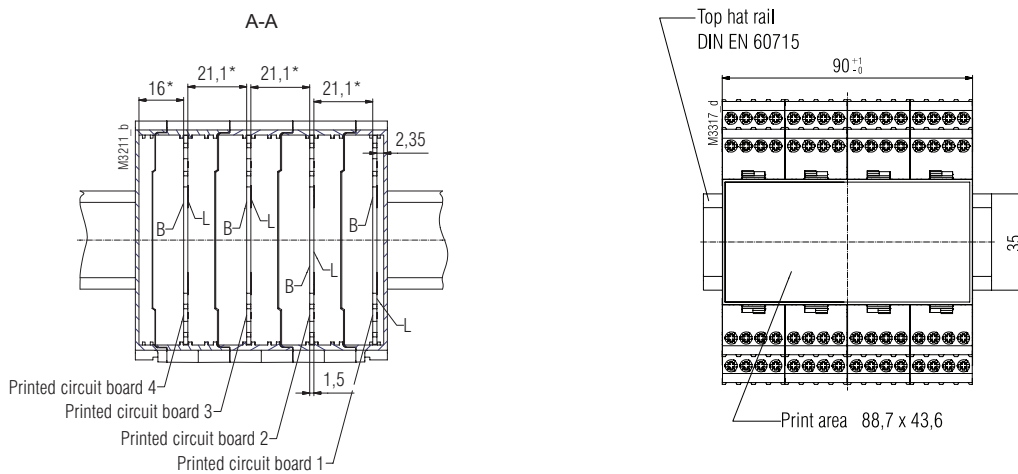

B = Component side
L = Solder side
* = max. component height
Printed circuit board configuration are possible

Printed circuit board design

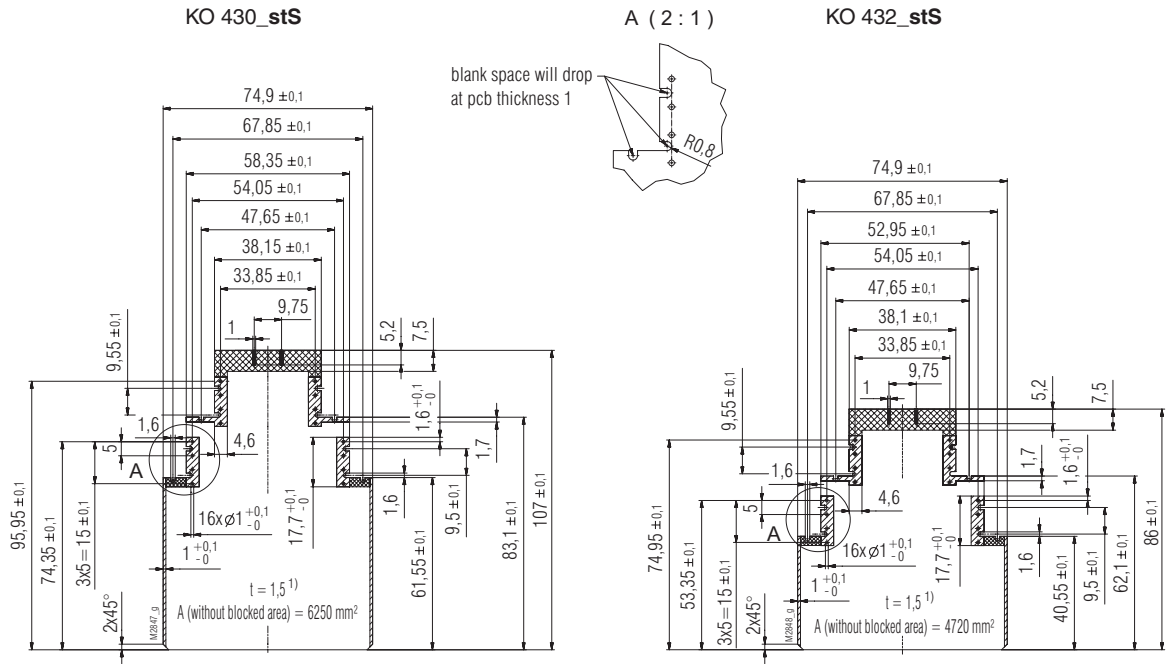

- Land for soldering ∅2
- Blocked area, free of components and conducting material
- Blocked area
- Reduced component height (with pcb thickness = 1,5):
 - under side max. 1,65
 - top side max. 15,2
- under side: Blocked area, free of components
- top side: Reduced component height max. 14,1 (with pcb thickness = 1,5)
- ¹⁾ Tolerance to DIN EN 60249-2-4
- general tolerance : PERFAG 2 E
- Drillings for terminal blocks plated-through 25µm.....50µm

Diagrams (Thermal Resistance)

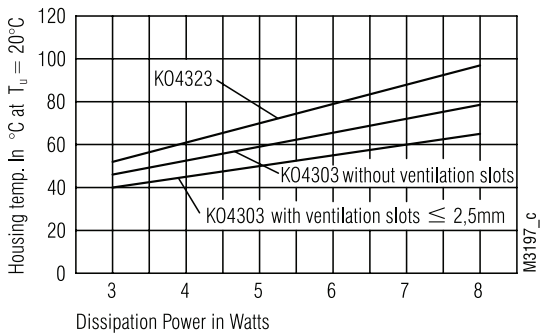

KO 4303stS, KO 4323stS

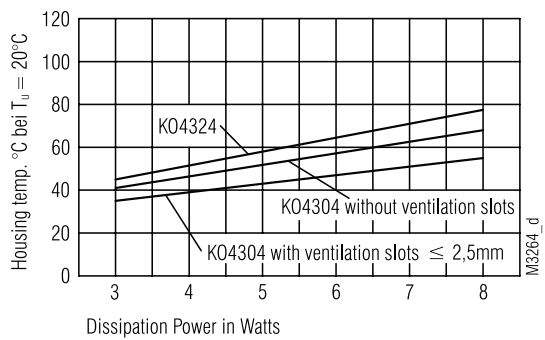

KO 4304stS, KO 4324stS

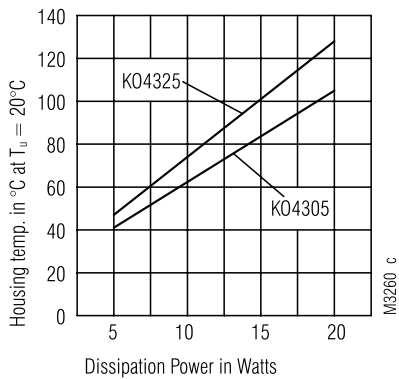

KO 4305stS, KO 4325stS

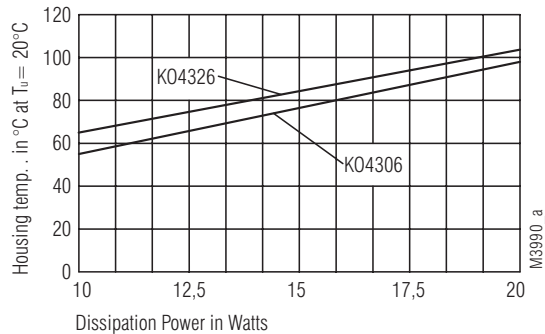

KO 4306stS, KO 4326stS

Notes on Housing Installation

1. Installation of upper section

- Place all assemblies on a level surface.
- Push the side parts over the terminal blocks of the equipped printed circuit board; in doing so, the guide pins of the terminal blocks must slide into the drilled holes in the side parts
- Snap the front plate onto the premounted side parts
- Mounting the pluggable terminal connectors

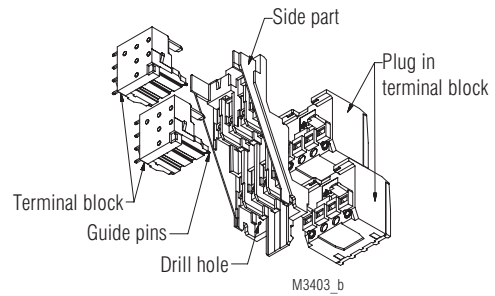

2. Installation of housing

- Place all assemblies on a level surface.
- Slide the printed circuit board of the upper section into the guide grooves of the base.
- When placing the hood and upper section together, ensure that the wall areas overlap correctly. The guide element of the base must slide into the guide recess of the upper section.

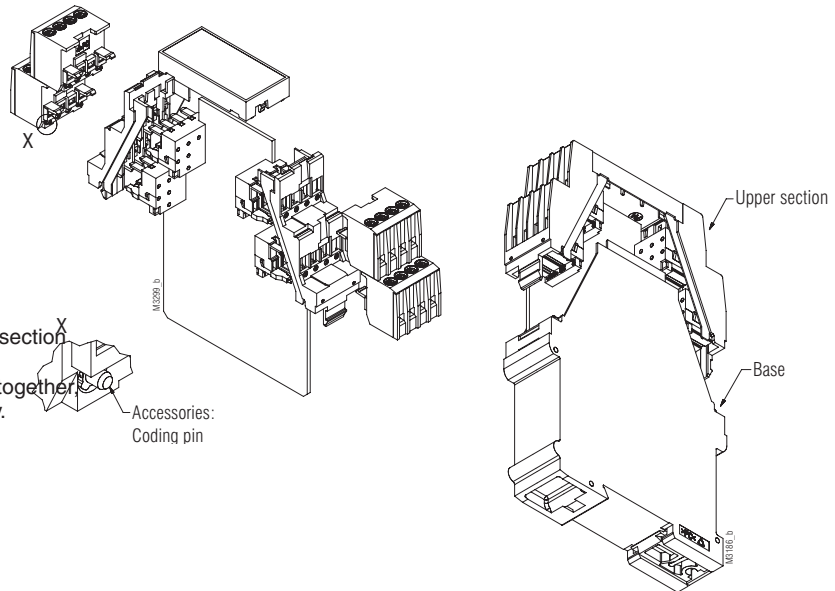

Notes on Housing Deinstallation

1. Removing the pluggable terminal connectors

- Insert a screwdriver in the front recess between connector and front plate.
- Turn the screwdriver to the right and left.

2. Removing the front plate

- Insert a screwdriver in the side recess of the front plate.
- Turn the screwdriver to the right and left.

3. Removing the upper section

- Insert a screwdriver in the snap fastener of the base as far as it will go.
- With a tilting movement, release the snap faster
- Pull the upper section with the printed circuit board out of the base.

