

Insulated Enclosure KO 4731

with twin-level box terminal
for plug-in technology



KO 4731
without terminal
Terminal block
release slots

- Width 45 mm
- Max. 28 box terminals with captive plus-minus terminal screws
- Twin level terminal
- Removable terminal blocks for connection with printed circuit board
- Terminal blocks with choice of 3, 4 or 7 terminals or as blanking block
- Interchangeable plate
- Installation of SMD components on outer surface (soldering side) possible
- can be used for EExi complying with EN 50 020
- Delivered: as kit

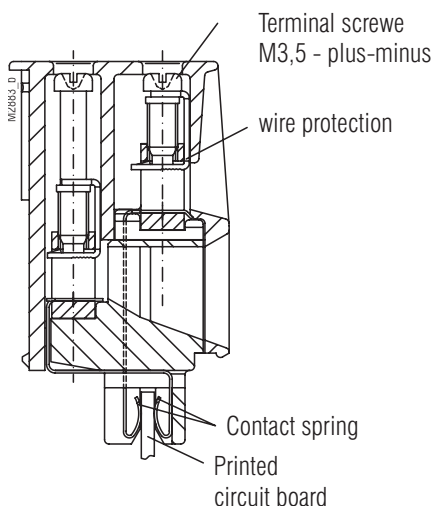

Twin-level box terminal (connectable)

Approval and Marking



Technical Data

Order reference:	beige	grey RAL 7035	blue RAL 5015	clear	black
Base, with one clip PC	KO 4731-	1.3			1.1
Base, with one clip PA (UL)	KO 4731-				1.6
Base, with one clip PBT (UL)	KO 4731-	1.7			
Frame 14-poles PC (UL)	KO 4731-	2-1.1	2-1.3	2-1.4	
Frame 28-poles PC (UL)	KO 4731-	2-2.1	2-2.3	2-2.4	2-2.5
Plate without terminal block release slots PC (UL)	KO 4730-	2-2.11	2-2.13	2-2.14	2-2.15
Plate with terminal block release slots PC (UL)	KO 4731-	5-1.1	5-1.3	5-1.4	5-1.5
Terminal block, 3 term. PC	KO 4733-	3.21	3.23	3.24	
Terminal block, 3 term. PA (UL)	KO 4733-				3.126
Terminal block, 3 term. PBT (UL)	KO 4733-		3.158		
Terminal block, 4 term. PC	KO 4733-	3.11	3.13	3.14	
Terminal block, 4 term. PA (UL)	KO 4733-				3.124
Terminal block, 4 term. PBT (UL)	KO 4733-		3.157		
Terminal block, 7 term. PC	KO 4733-	3.1	3.3	3.4	
Terminal block, 7 term. PA (UL)	KO 4733-				3.123
Terminal block, 7 term. PBT (UL)	KO 4733-		3.156		
Blanking block PC	KO 4733-	3.31	3.33	3.34	

Outer dimensions: 45 x 84 x 118 mm
Enclosure material: PC-GF, base black,
 Front color, see table

Temperature stability:	PC	PA	PBT
complying with UL 746 B:	125 °C	120 °C	120 °C
complying with Vicat Meth. A:		212 °C	
ISO 306 Meth. B:	148 °C	212 °C	134 °C
compl. with ISO 75-2 Meth. A:	138 °C	230 °C	145 °C
Meth. B:	144 °C	210 °C	150 °C

max. permitted power dissipation: 15 W for stand-alone enclosure
 at normal climate 23/50-1 ISO 554

specific thermal resistance: $R_{th} = 6.5 \text{ K/W}$ for stand-alone enclosure

Flame retardancy:
 complying with UL 94: PC: V-0; PA: V-0; PBT: V-0
 complying with IEC 60 707: BH 2-30

Number of terminals: max. 28; less on request

Terminal material: Cu-alloy tin-plated

Max. cross section for connection: each 1 x 2.5 mm² stranded ferruled DIN 46 228-1/-2/-3/-4
 each 1 x 4 mm² solid
 each 2 x 1.5 mm² stranded ferruled

Insulation of wires length: 10 mm

Max. contact resistance to
 printed circuit board: 15 mΩ

Max. current carrying capacity of terminal blocks:	(UL) Ex. 1	Ex. 2	Ex. 3	(UL) Ex. 4	Ex. 5	(UL) Ex. 6
$\infty \Sigma I_{max} = 15 \text{ A}$	5 5					
$\infty \Sigma I_{max} = 28 \text{ A}$	7 7 7 7	8 6 7 7	8 6 8 6			
$\infty \Sigma I_{max} = 35 \text{ A}$	5 5 5 5 5 5 5 5	5 5 5 5 8 4 4 4	3 2 2 8 6 7 7	2 3 2 7 7 7 7	1 1 5 8 6 8 6	5 5 5 3 7 7 3

□ = max. value per terminal point, □ = max. value per terminal row

Wire fastening: captive plus-minus terminal screws M3.5
 Box terminals with self-raising wire protection

Torque: max. 0.8 Nm

Technical Data

Connection inside:	Direct connection of printed circuit board		
Enclosure fastener:	Snap-on fastener on top hat rail or screwed connection M4, grid 86 mm	EN 50 022	
Creepage current resistance:	PC: CTI 175 $\hat{=}$ insulating material III a	IEC 60 664-1	
	PA: CTI 600 $\hat{=}$ insulating material I	IEC 60 664-1	
	PBT: CTI 225 $\hat{=}$ insulating material III	IEC 60 664-1	
Air gap and creepage distance:	≥ 3.3 mm complying with with printed circuit board inserted	61 010-1	
Type of protection:	Enclosure IP 40	IEC 60 529	
	Terminals IP 20 contact protection complies with VBG 4	IEC 60 529	
Print area:	on the front plate 45 x 33 mm		
Printed circuit board size:	① = 30 cm ² , ①a und ①b = 37 cm ² , ② = 55 cm ² ②a = 67 cm ²		
Printed circuit board holder:	Guide ribs in base		
Net weight:	200 g		

Accessories:		beige	grey RAL 7035	blue RAL 5015	black
Legend plate	KO 4730-	3-1.1	3-13	3-1.4	3-1.5
2 clips for screw fastener	ET 4086-0-2				

Exploded view

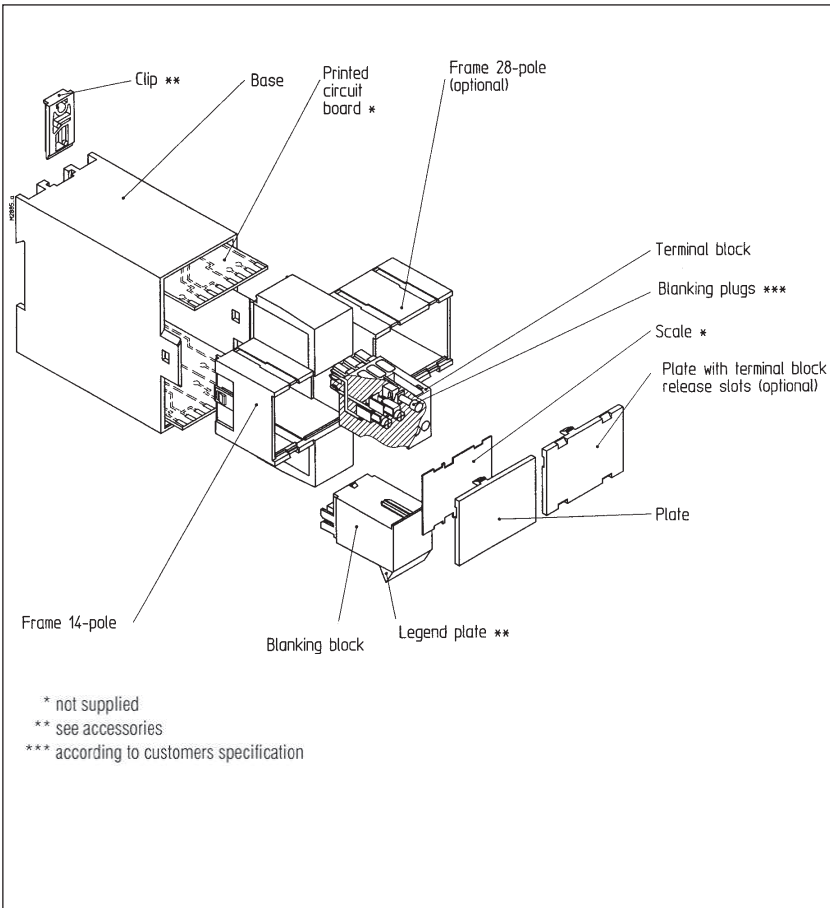

Scala

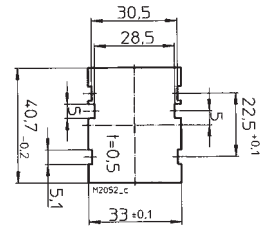

Dimensions

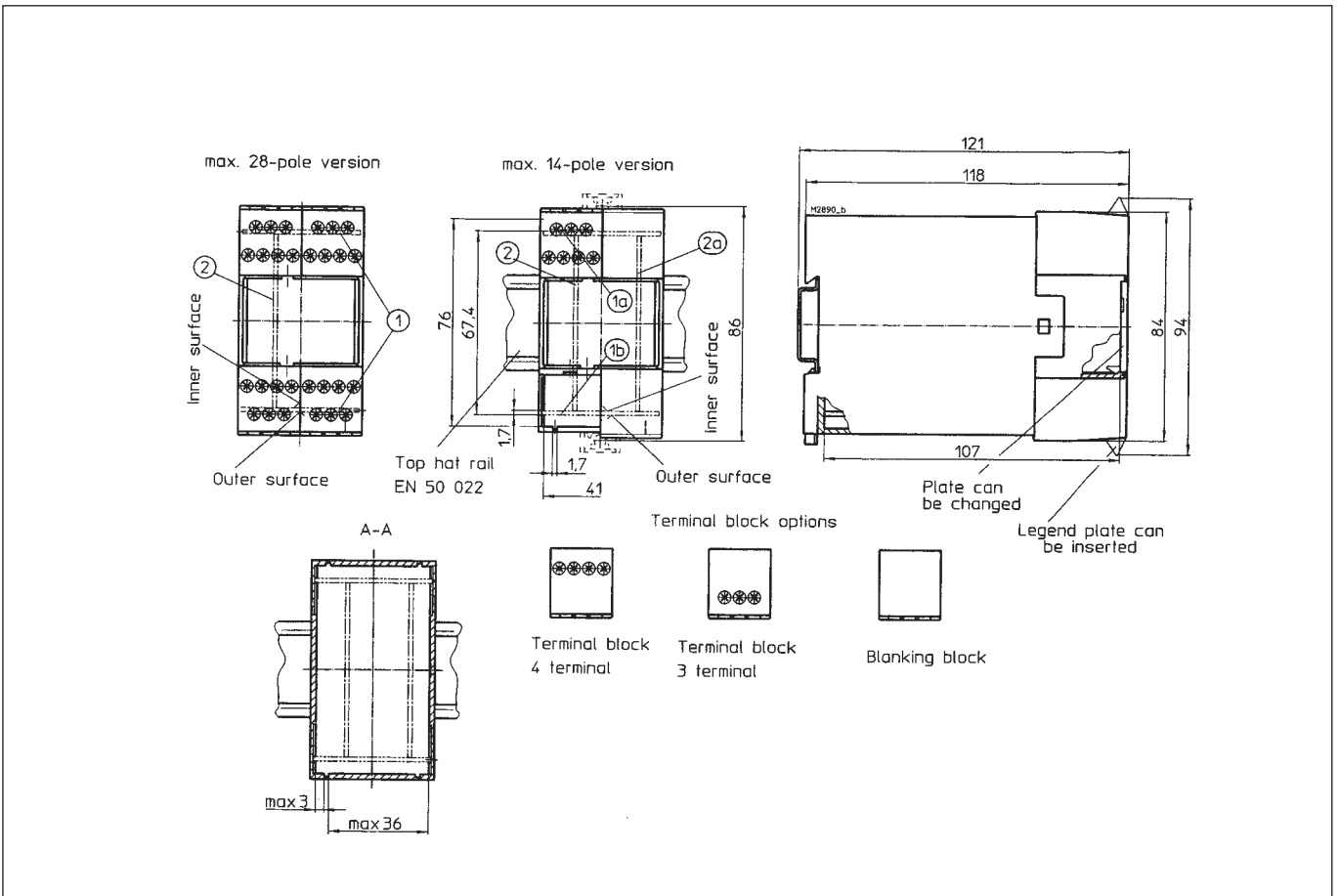

Printed circuit board design

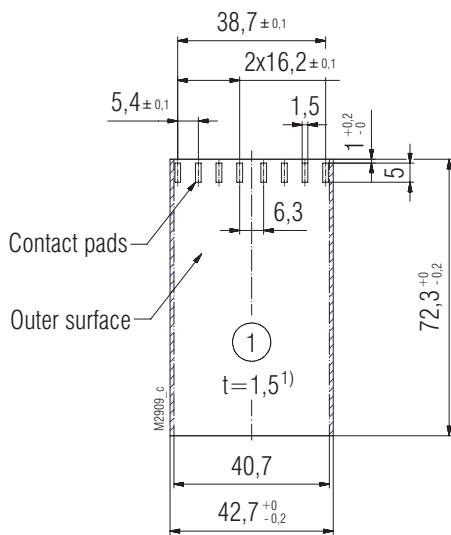

Recommendation for tin plating of contact pads
Pure tin Sn100, 10.....30µm thickness

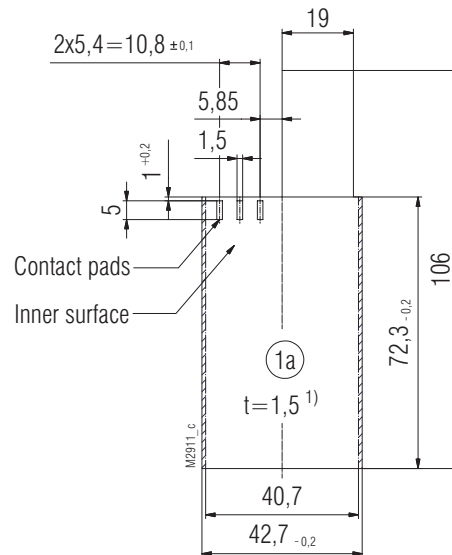
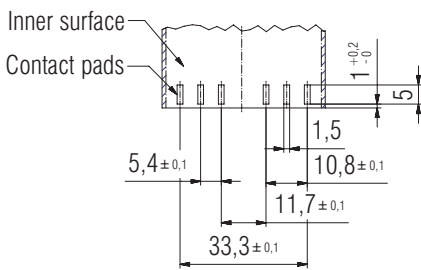

Recommendation for tin plating of contact pads
Pure tin Sn100, 10.....30µm thickness

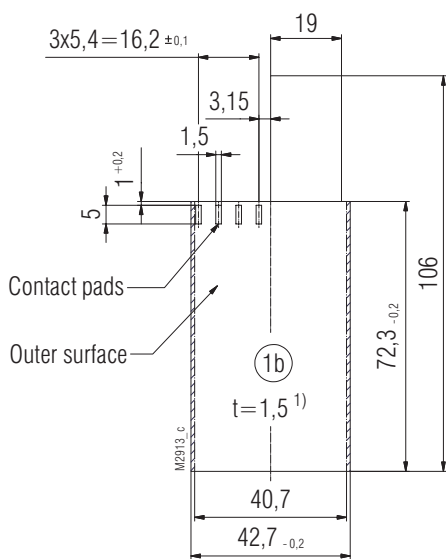
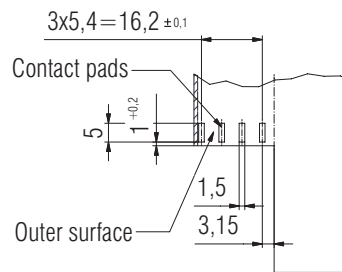

Recommendation for tin plating of contact pads
Pure tin Sn100, 10.....30µm thickness

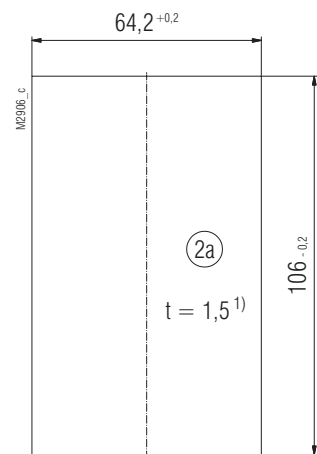
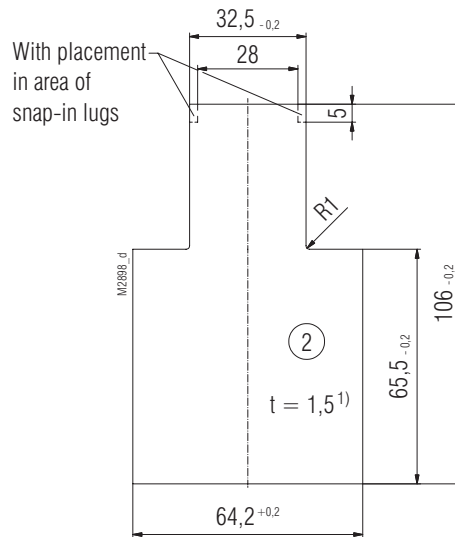
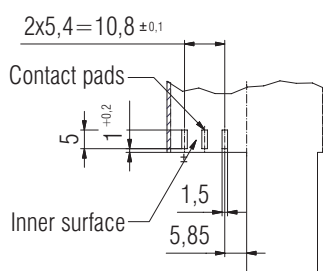

 Inhibited surface

¹⁾ Tolerance to DIN EN 60249-2-4
General tolerance: PERFAG E2

1. Tool

- For all functions, use 0,8 x 4,0 or 0,8 x 4,5 screwdriver

2. Removing terminal blocks

- Insert a screwdriver in the slots of the plate
- Unlock the terminal blocks by moving the screwdriver in the direction of the arrow
- Remove the terminal blocks
- **Note: It is not possible to remove the terminal blocks in the case of the plate without terminal block release slots**

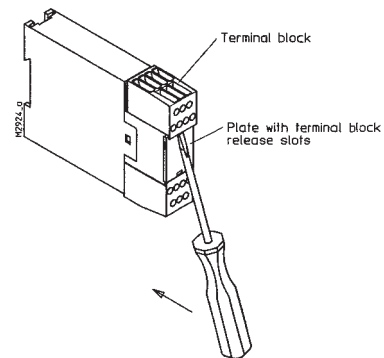

3. Removing the frame

- The terminal blocks must have been removed.
- Insert a screwdriver in the side recesses of the hood (underneath)
- With light pressure, turn the screwdriver to the right or left
- The snap-in lug of the frame disengages
- Repeat disengaging process on opposite side
- The frame can be removed

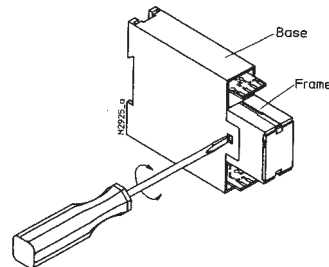

4. Removing the plate

- Insert a screwdriver in the side recess of the plate
- Turn the screwdriver to the right or left
- The plate disengages and can be removed

