

Insulated Enclosure KO 4733

with twin-level box terminal
for plug-in technology

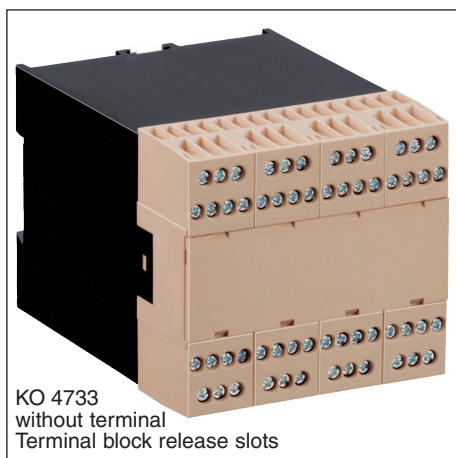

KO 4733
without terminal
Terminal block release slots

- Width 90 mm
- Max. 56 box terminals with captive plus-minus terminal screws
- Twin level terminal
- Removable terminal blocks for connection with printed circuit board
- Terminal blocks with choice of 3, 4 or 7 terminals or as blanking block
- Interchangeable plate
- Installation of SMD components on outer surface (soldering side) possible
- can be used for EExi complying with EN 50 020
- Delivered: as kit

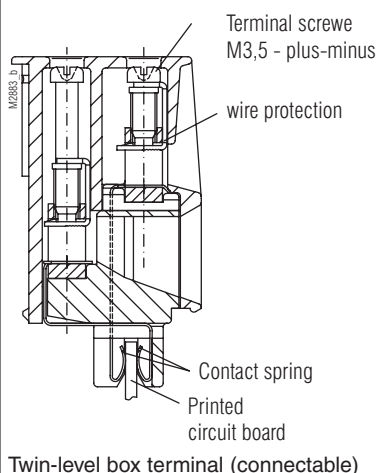

Twin-level box terminal (connectable)

Approval and Marking



Technical Data

Order reference:	beige	grey RAL 7035	blue RAL 5015	clear	black
Base, with one clip PC	KO 4733-	1.6			1.1
Base, with one clip PA (UL)	KO 4733-				1.4
Base, with one clip PBT (UL)	KO 4733-	1.5			
Frame PC (UL)	KO 4733-	2-1.1	2-1.3	2-1.4	2-1.7
Plate without terminal block					
release slots PC (UL)	ET 4720-	59-2.21	59-2.23	59-2.24	59-2.25
Plate with terminal block					
release slots PC (UL)	KO 4733-	13-1.1	13-1.3	13-1.4	13-1.5
Terminal block, 3 term. PC	KO 4733-	3.21	3.23	3.24	
Terminal block, 3 term. PA (UL)	KO 4733-				3.126
Terminal block, 3 term. PBT (UL)	KO 4733-		3.158		
Terminal block, 4 term. PC	KO 4733-	3.11	3.13	3.14	
Terminal block, 4 term. PA (UL)	KO 4733-				3.124
Terminal block, 4 term. PBT (UL)	KO 4733-		3.157		
Terminal block, 7 term. PC	KO 4733-	3.1	3.3	3.4	
Terminal block, 7 term. PA (UL)	KO 4733-				3.123
Terminal block, 7 term. PBT (UL)	KO 4733-		3.156		
Blanking block PC	KO 4733-	3.31	3.33	3.34	

Outer dimensions: 90 x 84 x 118 mm
Enclosure material: PC-GF, base black,
 Front color, see table

Temperature stability:	PC	PA	PBT
complying with UL 746 B:	125 °C	120 °C	120 °C
complying with Vicat Meth. A:		212 °C	
ISO 306 Meth. B:	148 °C	212 °C	134 °C
compl. with ISO 75-2 Meth. A:	138 °C	230 °C	145 °C
Meth. B:	144 °C	210 °C	150 °C

max. permitted power dissipation: 25 W for stand-alone enclosure
 at normal climate 23/50-1 ISO 554

specific thermal resistance: $R_{th} = 4 \text{ K} / \text{W}$ for stand-alone enclosure

Flame retardancy:
 complying with UL 94: PC: V-0; PC: plate clear = V-2; PA: V-0; PBT: V-0
 complying with IEC 60 707: BH 2-30



Number of terminals: max. 56; less on request

Terminal material: Cu-alloy tin-plated

Max. cross section for connection: each 1 x 2.5 mm² stranded ferruled DIN 46 228-1/-2/-3/-4
 each 1 x 4 mm² solid
 each 2 x 1.5 mm² stranded ferruled

Insulation of wires length: 10 mm

Max. contact resistance to printed circuit board: 15 mΩ

Max. current carrying capacity of terminal blocks:	(UL) Ex. 1	Ex. 2	Ex. 3	(UL) Ex. 4	Ex. 5	(UL) Ex. 6
 Σ I _{max} = 15 A	5 5 5					
 Σ I _{max} = 28 A	7 7 7 7	8 6 7 7	8 6 8 6			
 Σ I _{max} = 35 A	5 5 5 5 5 5 5	5 5 5 8 4 4 4	3 2 2 8 6 7 7	2 3 2 7 7 7 7	1 1 5 8 6 8 6	5 5 5 3 7 7 3

 = max. value per terminal point,  = max. value per terminal row

Technical Data

Wire fastening:	captive plus-minus terminal screws M3.,5 Box terminals with self-raising wire protection	
Torque:	max. 0.8 Nm	
Connection inside:	Direct connection of printed circuit board	
Enclosure fastener:	Snap-on fastener on top hat rail or screwed connection M4, grid 86 mm	EN 50 022
Creepage current resistance:	PC: CTI 175 $\hat{=}$ insulating material III a	IEC 60 664-1
	PA: CTI 600 $\hat{=}$ insulating material I	IEC 60 664-1
	PBT: CTI 225 $\hat{=}$ insulating material III	IEC 60 664-1
Air gap and creepage distance:	≥ 3.3 mm complying with with printed circuit board inserted	61 010-1
Type of protection:	Enclosure IP 40	IEC 60 529
	Terminals IP 20	IEC 60 529
Print area:	contact protection complies with VBG 4 on the front plate 90 x 33 mm	
Printed circuit board size:	① = 63 cm ² , ③ = 54 cm ² , ④ = 27 cm ² , ⑥ = 55 cm ²	
Printed circuit board holder:	2 guide ribs on the small side and screw fixing in front frame	
Net weight:	300 g	

Accessories:		beige	grey RAL 7035	blue RAL 5015	black
Legend plate	KO 4730-	3-1.1	3-13	3-1.4	3-1.5
2 clips for screw fastener	ET 4086-0-2				

Exploded view

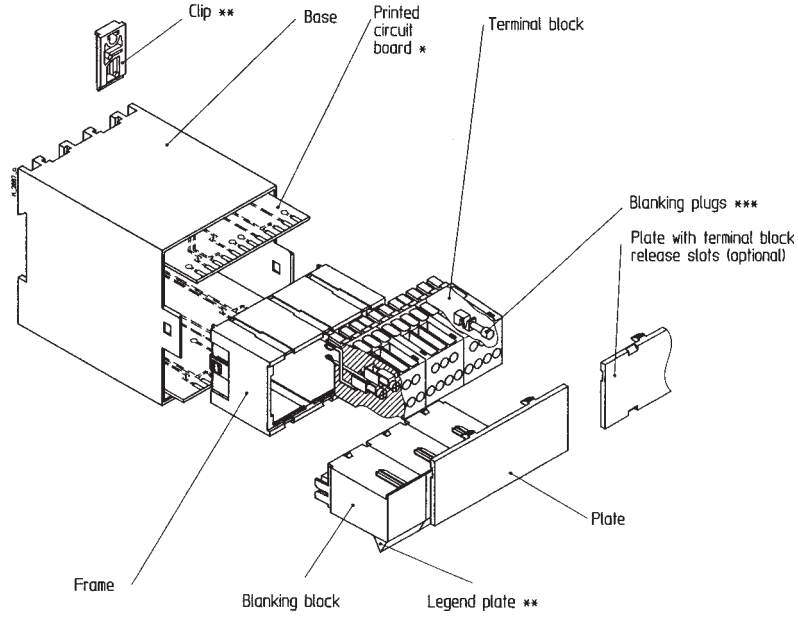

* not supplied
 ** see accessories
 *** according to customers specification

Scala

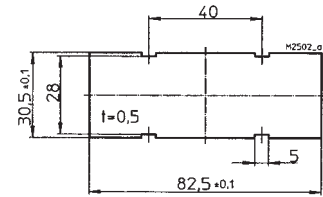

Dimensions

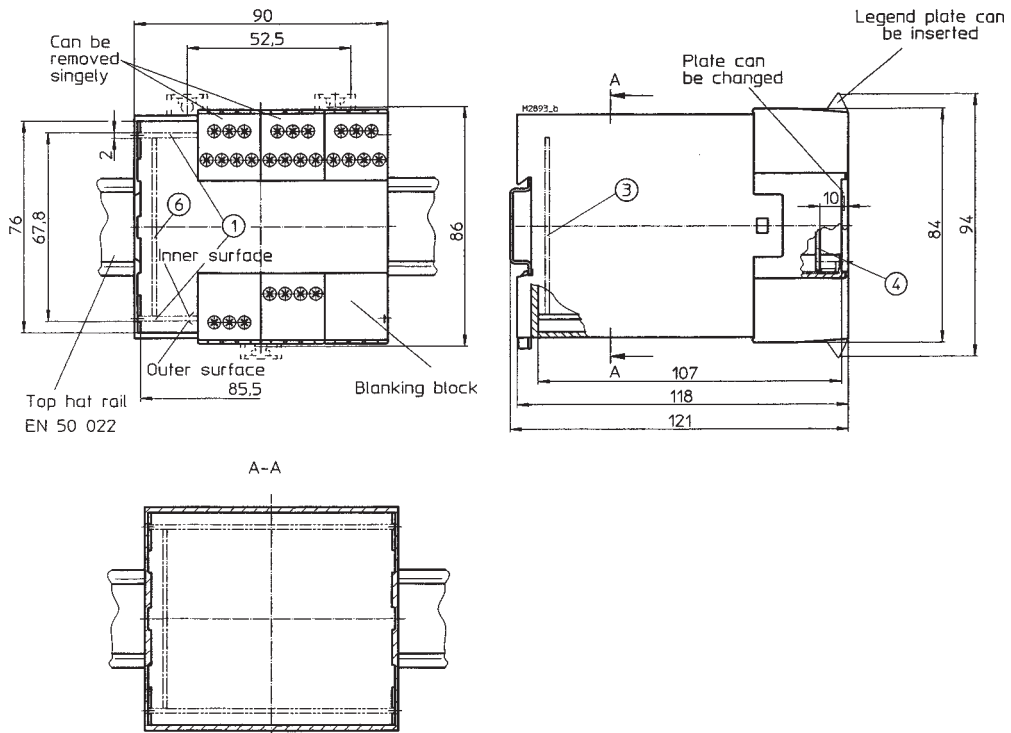

Printed circuit board design

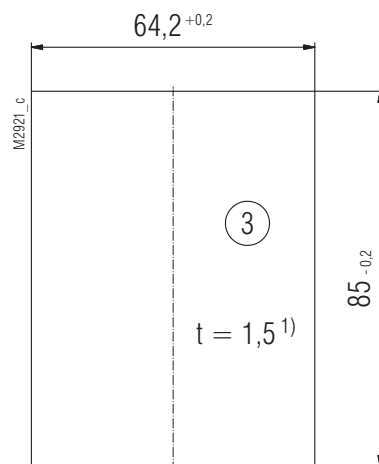
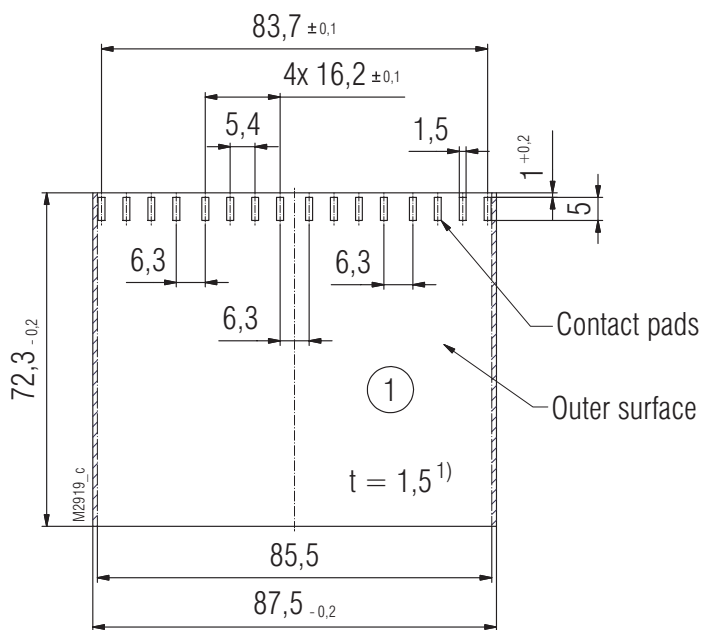

Recommendation for tin plating of contact pads.
Pure tin Sn100, 10.....30µm thickness

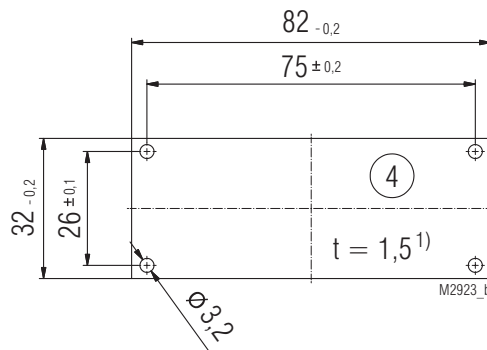
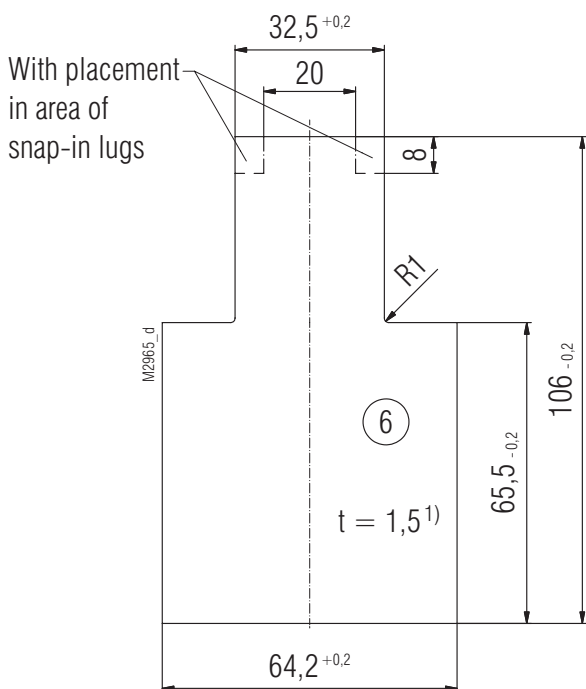
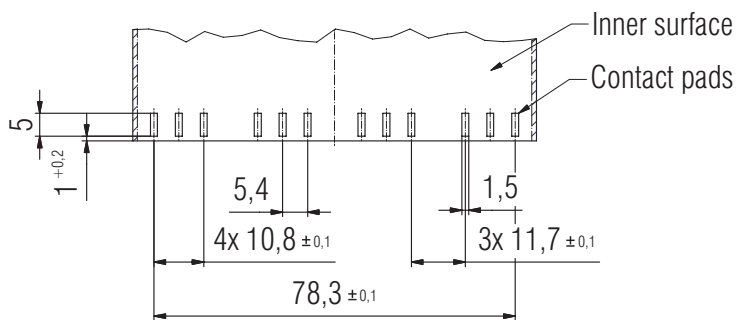

 Inhibited surface

¹) Tolerance to DIN EN 60249-2-4
General tolerance: PERFAG E2

1. Tool

- For all functions, use 0.8 x 4.0 or 0.8 x 4.5 screwdriver

2. Removing terminal blocks

- Insert a screwdriver in the slots of the plate
- Unlock the terminal blocks by moving the screwdriver in the direction of the arrow
- Remove the terminal blocks
- **Note: It is not possible to remove the terminal blocks in the case of the plate without terminal block release slots**

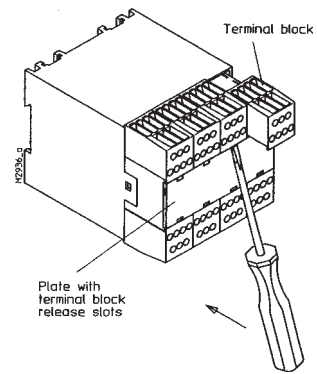

3. Removing the frame

- The terminal blocks must have been removed.
- Insert a screwdriver in the side recesses of the hood (underneath)
- With light pressure, turn the screwdriver to the right or left
- The snap-in lug of the frame disengages
- Repeat disengaging process on opposite side
- The frame can be removed

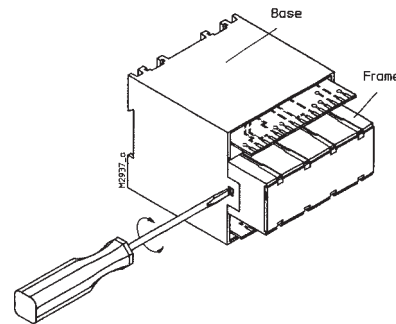

4. Removing the plate

- Insert a screwdriver in the side recess of the plate
- Turn the screwdriver to the right or left
- The plate disengages and can be removed

