

Insulated Enclosures KU 4584

to DIN 43 880 for installation in distribution cabinets
55 mm depth

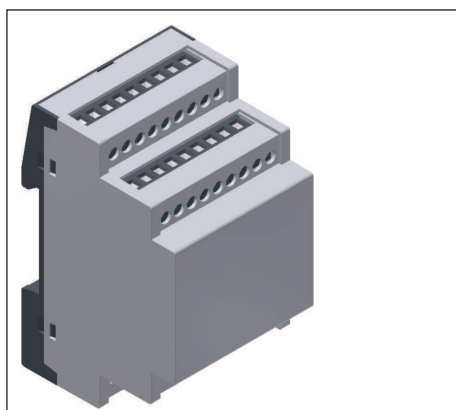

Your Advantages

- Modular and flexible
- Plenty of space
- Variable connection system
- Can be specifically tailored to customer requirements

Features

- Module widths 52.5 mm
- Nominal depth 53 mm for overall panel depth maximum 55 mm to DIN 43 880
- Selectable enclosure configurations
 - without terminal
 - with printed circuit board terminals
 - with plug in screw terminals
 - with plug in cage clamp terminals
 - with various terminal combinations
- Suited for the accommodation of up to two horizontal PCBs with terminals and additional PCB for display and control or elements in the housing front; optionally for the accommodation of up to 6 vertical PCBs with terminals
- Enclosure openings for connection terminals, control elements and bus connectors KNX and RJ45 on request
- Base plates available with side walls for mounting of PCB assemblies

Technical Data

Order reference: UL
 Closed: 0066459
 PCB terminal: 0066460
 Plug in screw terminal: 0066461
 Plug in cage clamp terminal: 0066674

External dimensions: 52.5 x 90 x 60

Enclosure material
 Cover: PC-GF, PC (UL) light grey RAL 7035
 Base plate: PC-GF, PC (UL) dark black RAL 9005

Temperature stability	PC (UL)
complying with UL 746 B:	115 °C
complying with Vicat ISO 306	Meth. B: 146 °C
compl. with ISO 75-2 (1.8 MPa):	123 °C
(0.45 MPa):	142 °C

Max. permitted power dissipation: 6 W for stand-alone enclosure
 at normal climate 23/50-1 ISO 554

Specific thermal resistance: $R_{th} = 10 \text{ K / W}$

Flame retardancy
 complying with UL 94: All Enclosure materials: V-0

Number of terminals: 36; less on request

Enclosure fastener: Snap-on fastener on top hat rail EN 60 715

Creepage current resistance
 PC: CTI 225 $\hat{=}$ insulated material III a IEC 60 112

Type of protection: Enclosure IP 40 IEC 60 529
 Base plate IP 30
 (connector cut outs IP 20)

Print area: 50 x 41.5 mm

Print circuit board: See printed circuit board design

Printed circuit board mounting
 horizontal: Fixed to the base by screws and / or
 by the side walls
 vertical: Guides in base and terminal plate

**More information see
 brochure
 Terminal overview GE02**

Exploded view

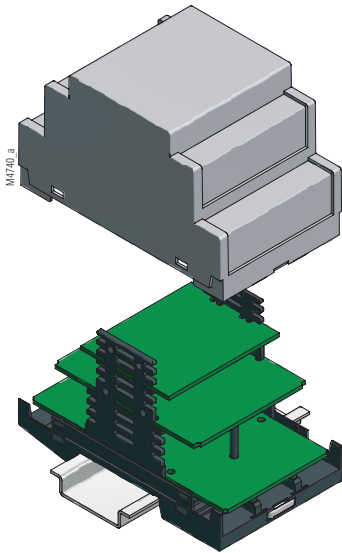

closed

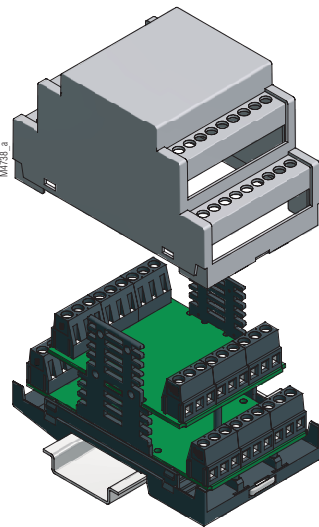

printed circuit board terminal

Dimensions

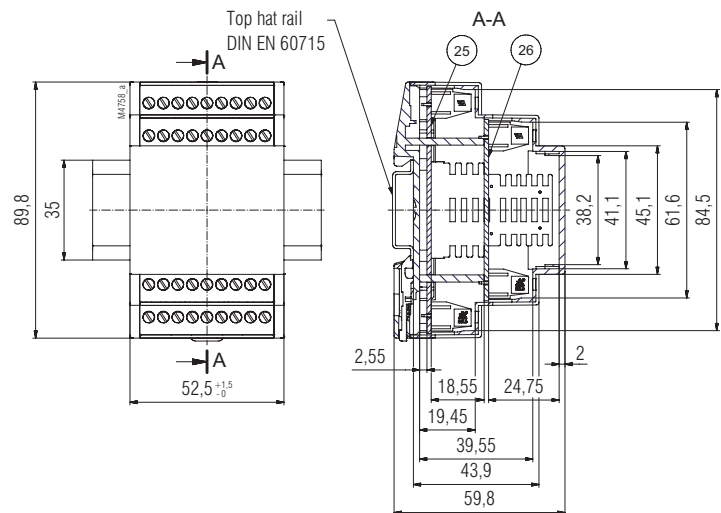
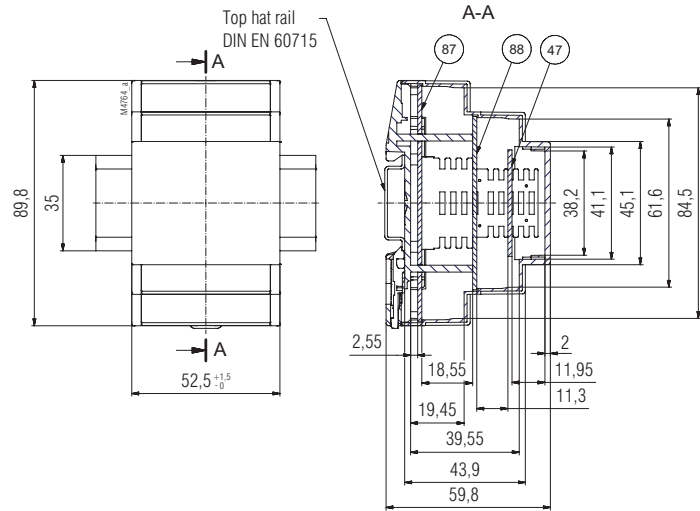

Exploded view

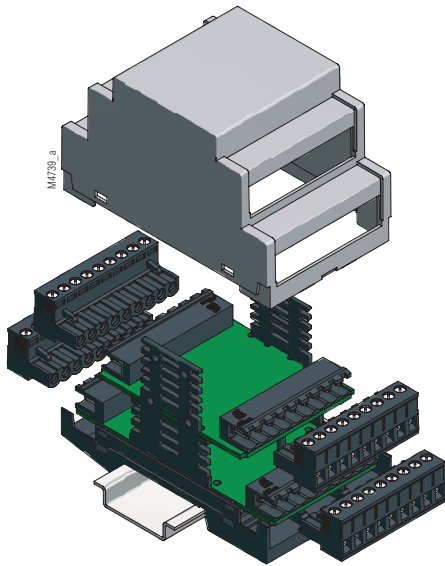

plug in screw terminal

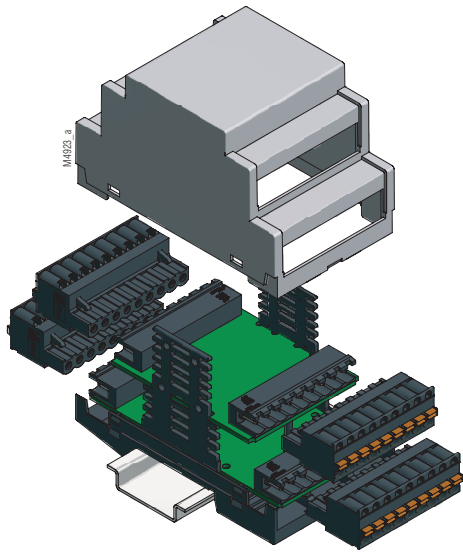

plug in cage clamp terminal

Dimensions

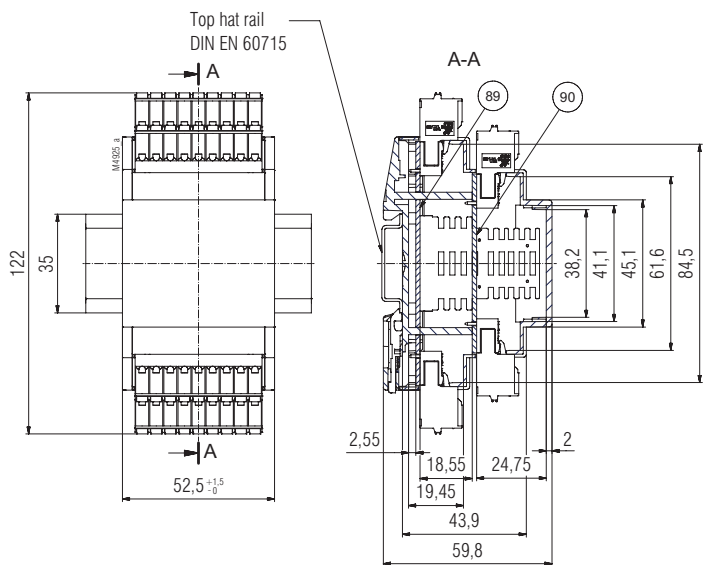
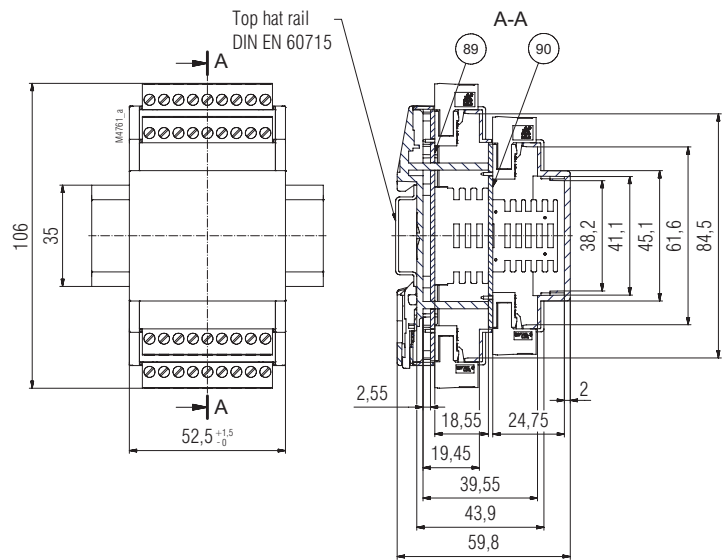

Printed circuit board design

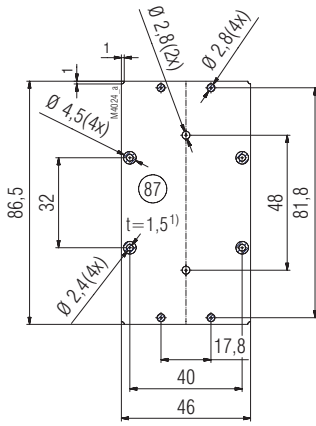

PCB in PCB-position Bottom for closed res. milled enclosure

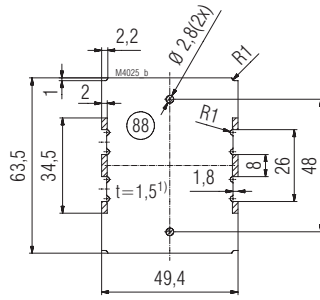

PCB in PCB-position Middle for closed res. milled enclosure

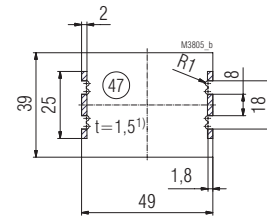

PCB in PCB-position Front for closed res. milled enclosure

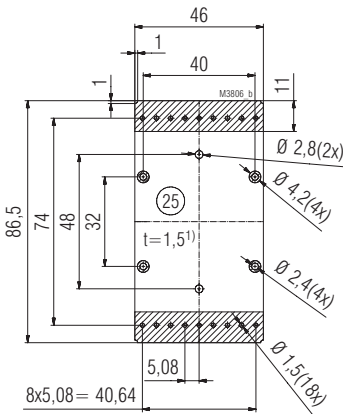

PCB in PCB-position Bottom for 2 x 9-pole PCB terminals

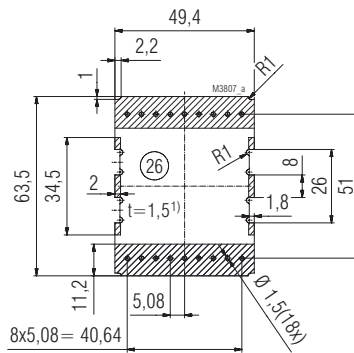

PCB in PCB-position Middle for 2 x 9-pole PCB terminals

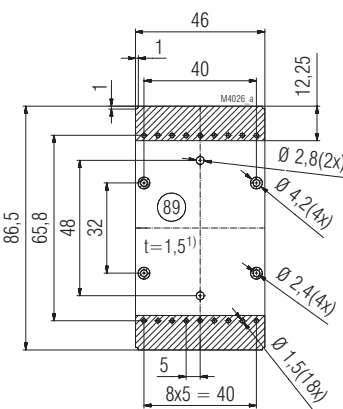

PCB in PCB-position Bottom for 2 x 9-pole contact tag row (plug in screw terminals e.g. plug in cage clamp terminals)

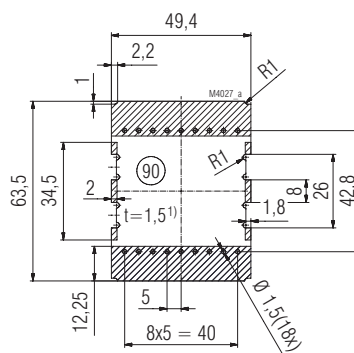

PCB in PCB-position Middle for 2 x 9-pole contact tag row (plug in screw terminals e.g. plug in cage clamp terminals)



1) Tolerance at DIN EN 60 249-2-4; General tolerance: PERFAG 2 E
Holes \varnothing 2,4 on request for cylindrical screws ISO 1207 M2x4