

Printed Circuit Board Relays

monostable

OA 5651, OA 5652, OA 5661, OA 5662, OA 5692

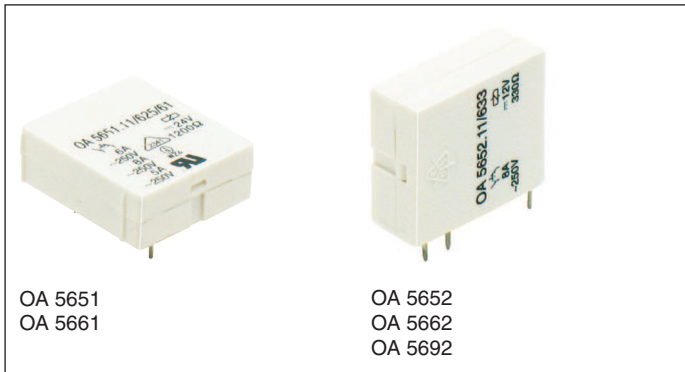

- According to DIN EN 61810-1, DIN EN 60664-1
- Different pin configurations and pin arrangements
- Clearance and creepage distances:
contact-coil ≥ 8 mm
- Compact size, small height (horizontal model)
- OA 5651, 5661 horizontal models
- OA 5652, 5662, 5692 vertical models
- Solder line proof

Applications

- Control technique
- Interface

Approvals and Markings



Technical Data

Relay type		OA 5651, OA 5652, OA 5661, OA 5662, OA 5692
1.0 Relay coil		
1.1 Nominal voltage	DC V	6, 12, 15, 20, 24, 48, 60 (others on request)
1.2 Nominal consumption	W	0.48
1.11 Voltage range	U_N	0.7 ... 1.8
1.13 Holding power (at 0.5 x U_N)	W	0.12
2.0 Contacts		
2.1 Contact arrangement		1 changeover contact ¹⁾
2.2 Contact material		AgSnO ₂ + 0.2 μ m Au; AgNi + 0.2 μ m Au
2.3 Rated insulation voltage	AC V	250
Switching voltage min./max.	V	10 / 400
2.4 Limiting continuous current I_{th}	A	8 (see operating voltage limit curve)
Switching current min./max.	A	10 mA ⁴⁾ / 10 ²⁾
2.5 Switching power min./max.	VA	4 / 2000
Switching power min./max.	W	30 ... 250 (see limit curve for arc-free operation)
2.6 Switching capacity to IEC/EN 60947-5-1		
AC 15		NC: 230 / 1; NO: 230 / 3
DC 13	AC V/A	NC: 24 / 1; NO: 24 / 1
to UL 508	DC V/A	B150
2.7 Electrical life		at 1 s On, 1 s Off (see contacts service life)
at AC 250 V, 8 A, $\cos\phi = 1$	switching cycles	$> 2 \times 10^5$ AgNi 10 $> 3 \times 10^5$ AgSnO ₂
2.8 Switching frequency max.	switching cycles/s	20
2.9 Response time / Release time	ms	typically 5 / typically 7
2.10 Contact force	cN	$> 25 / > 10^3 / > 8^3$
2.14 Contact gap	mm	$> 0,5^2)$
3.0 Other		
3.1 Mechanical life	switching cycles	30×10^6
3.2 Temperature range	$^{\circ}$ C	- 40 ... + 80
3.3 Degree of protection		Solder line proof RT II
3.5 Vibration resistance		≥ 4 g, to max. 100 Hz, IEC/EN 60068-2-6
3.6 Climate resistance		40 / 080 / 04 (climate category); A/B/D IEC/EN 60068-1

¹⁾ NO and NC on request

²⁾ max. 4 s or 10 % ED

³⁾ at OA 5651, OA 5652

⁴⁾ Typical values

Technical Data

3.8	Insulation acc. to IEC 60664-1, EN 50178		
	Rated insulation voltage	AC V	250
	Pollution degree		3
	Overtoltage category		III
	Test voltage		
	Contact- Coil (1 min)	AC kV eff.	≥ 4
	Transient voltage		
	Contact- Coil (1,2 - 50 μs)	kV	≥ 6
	Clearance and creepage distances	mm	≥ 8
3.9	Weight	g	13
4.0 Packing			
4.1	in blister	piece	20
4.2	in case package	piece	200
5.0 Solder method			
5.1	Solder method /-temperature /-duration	°C / s	Wafer soldering / 260 / 5

Design Versions

U _N DC V	Voltage range DC V	Resistance at 20°C Ω	AgNi10-contacts + 0.2 μm Au					AgSnO ₂ -contacts + 0.2 μm Au				
			OA 5651	OA 5652	OA 5661	OA 5662	OA 5692	OA 5651	OA 5652	OA 5661	OA 5662	OA 5692
6	4,2 ... 10,8	80	621	635	285	270	411	651	665	323	328	432
12	8,4 ... 21,6	330	622	636	286	271	412	652	666	324	329	433
15	10,5 ... 27,0	475	623	637	291	272	413	653	667	321	330	434
20	14,0 ... 36,0	880	624	638	287	273	414	654	668	325	331	435
24	16,8 ... 43,2	1 200	625	639	288	274	415	655	669	326	332	436
48	33,6 ... 86,4	4 700	626	640	289	275	416	656	670	327	333	437
60	42,0 ... 108,0	7 250	627	641	293	276	417	657	671	322	334	438

Ordering Example

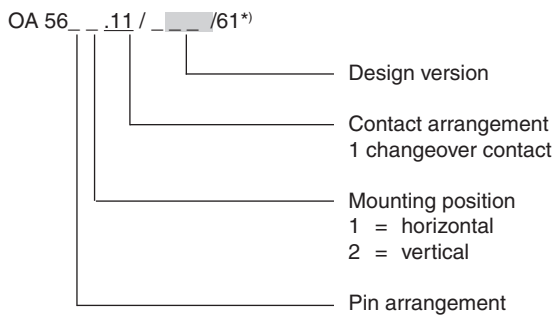

*) /61 cURus approval

Characteristics

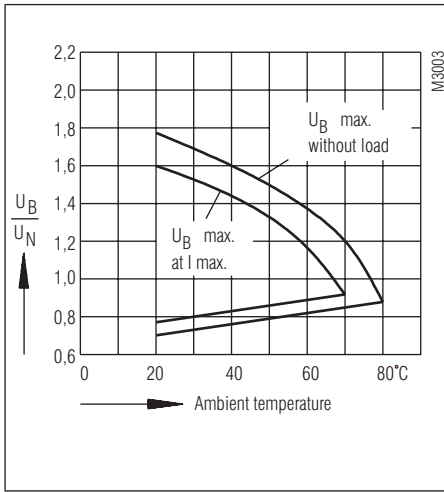

Operating voltage limit curve

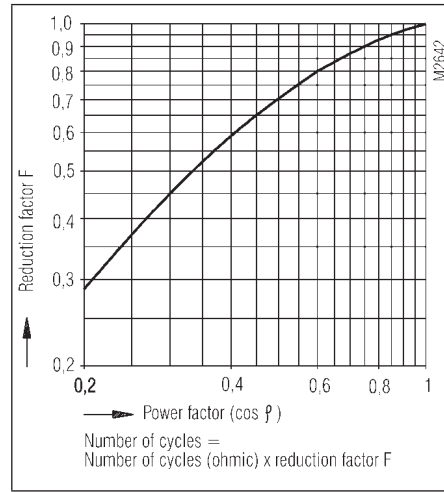

Reduction factor for inductive loads

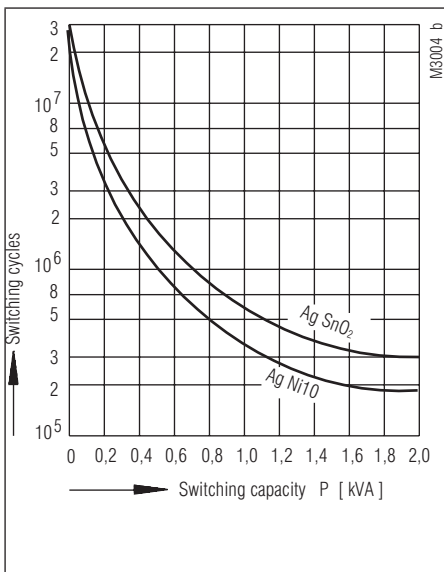

Contact service life (at $t_u = 20^\circ\text{C}$)

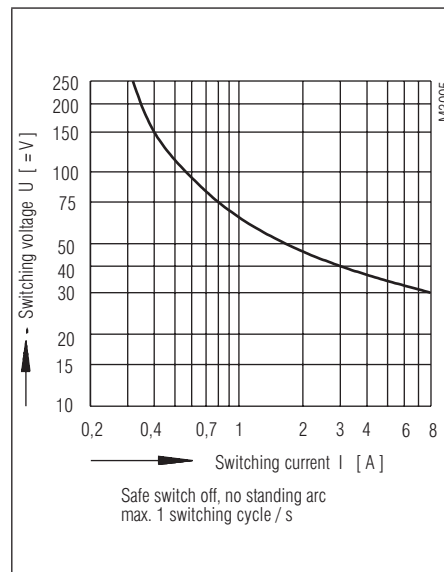

Limit curve for arc-free operation (at $t_u = 20^\circ\text{C}$)

Drilling plan (solder side)

OA 5651

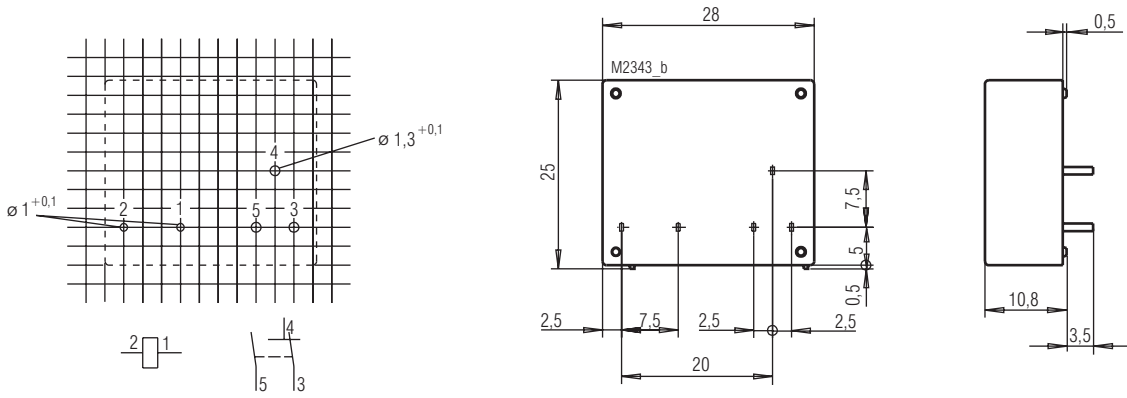

OA 5652

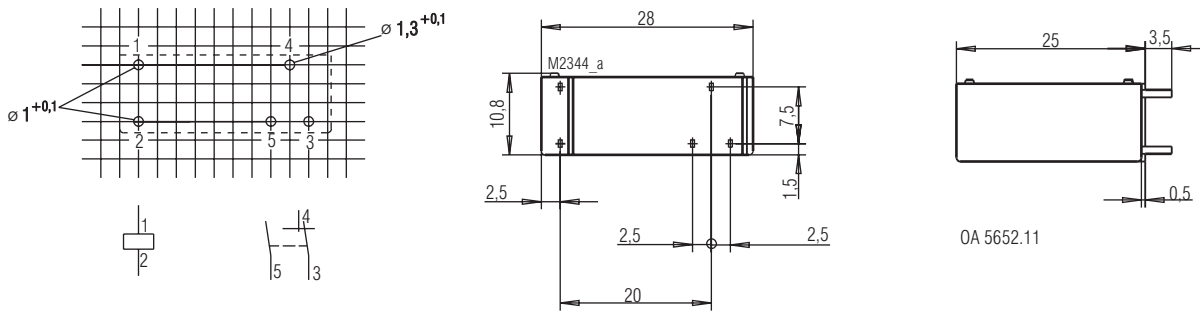

OA 5661

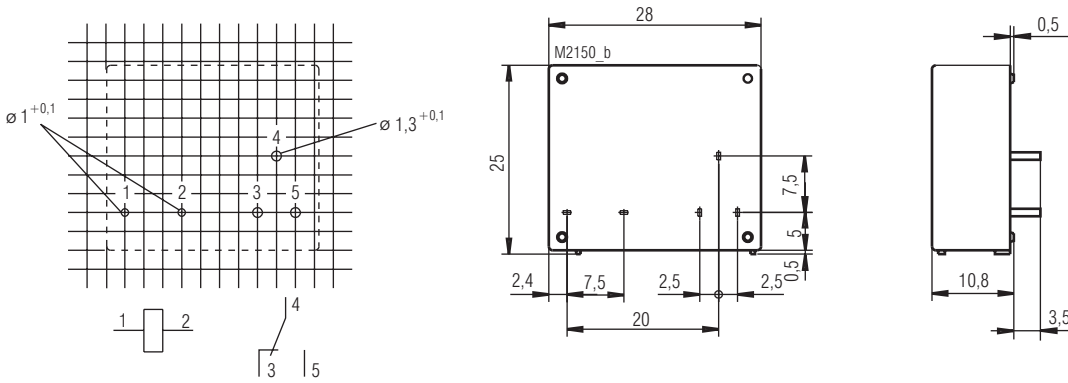

OA 5662

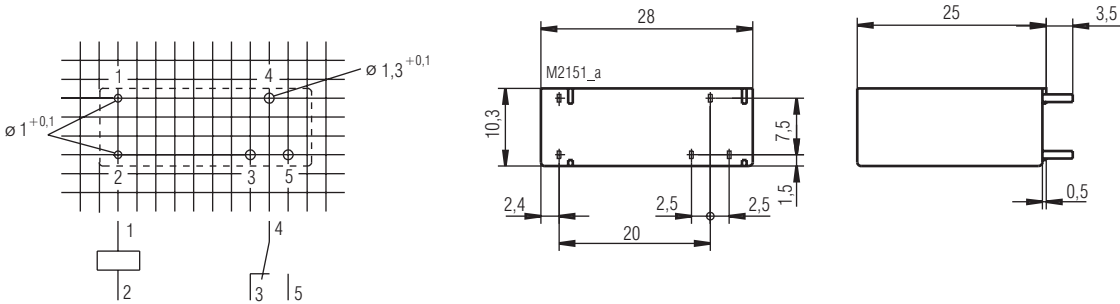

OA 5662.11

Connection for basic grid dimensions 2.5 mm as well as 2.54 mm according to IEC/EN 60097 and IEC 60326 average

Drilling plan (solder side)

OA 5692

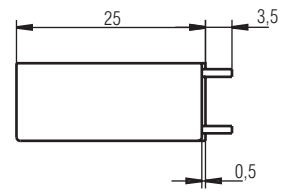
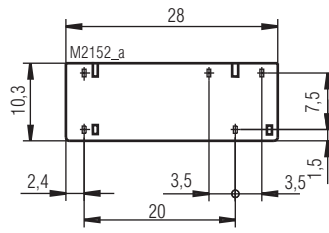
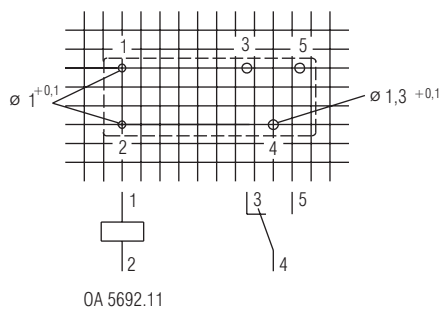

Connection for basic grid divisions 2.5 mm as well as 2.54 mm according to IEC/EN 60097 and IEC 60326 average

