

Safety relay

OA 5667/ _ _ _ _ 4

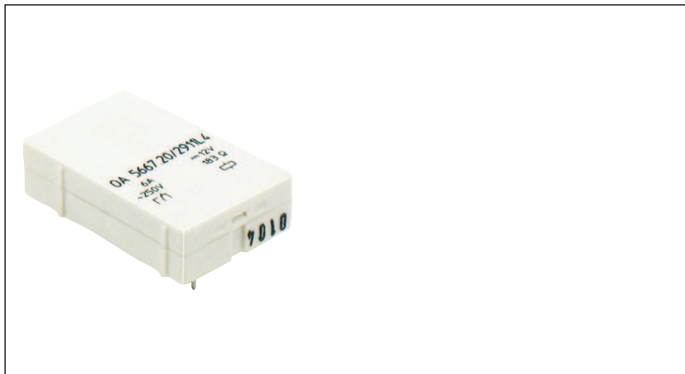

- According to DIN EN 61810-1, DIN EN 61810-3
- With forcibly guided contacts
- Clearance and creepage distances:
contact - coil ≥ 8 mm
contact - contact $\geq 5,5$ mm
- **Double and reinforced insulation between contacts**
- Low rated power consumption
- High voltage resistance ≥ 4 kV at pollution degree 2
- High mechanical service life
- Compact size, small height

Applications

- Switchgear for safety technology
- Press controls

Approvals and Markings

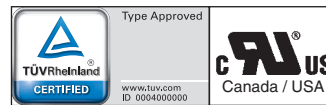

Technical Data

Relay type		OA 5667._ _ / _ _ _ _ 4	
1.0 Relay coil			
1.1 Nominal voltage	DC V	6, 12, 24, 48, 60, 110	
1.2 Nominal consumption	W	0.75	
1.11 Voltage range	U_N	0.75 ... 1.3	
1.13 Holding Power (at 0.5 x U_N)	W	0.19	
2.0 Contacts			
2.1 Contact arrangement		2 changeover contacts / 1 NO, 1 NC	
2.2 Contact material		AgSnO ₂ + 0.2 μ m Au; AgNi + 0.2 μ m Au, AgNi + 5 μ m Au	
2.3 Rated insulation voltage	AC V	250	
Switching voltage min./max.	V	AC/DC 10 / DC 250, AC 400 (AC/DC 2 V / 60 V) ¹⁾	
2.4 Limiting continuous current I_{th}	A	2 x 6 (see operating voltage limit curve)	
Switching current min./max.	A	10 mA ³⁾ / 6 (2 mA / 0.3 A) ¹⁾	
2.5 Switching power min./max.	VA	0.1 / 1 500 (10 mVA / 12 VA) ¹⁾	
Switching power min./max.	W	0.1 / 200 (10 mW / 12 W) ¹⁾ (see limit curve for arc-free operation)	
2.6 Switching capacity to IEC/EN 60947-5-1			
AC 15 ⁴⁾	AC V/A	NO: 250 / 3	NC: 250 / 1
AC 15 ⁵⁾	AC V/A	NO: 250 / 3	NC: 250 / 1
DC 13 ⁴⁾	DC V/A	NO: 24 / 2	NC: 24 / 1
DC 13 ⁴⁾ at 0.1 Hz to UL 508	DC V/A	NO: 24 / 4	NC: 24 / 3
		R300	
2.7 Electrical life	switching cycles	at 1 s On, 1 s Off (see contacts service life)	
at AC 250 V, 6 A, $\cos\phi = 1$	switching cycles	> 10 ⁵ AgNi 10	> 1.25 x 10 ⁵ AgSnO ₂
2.8 Switching frequency max.	switching cycles / s	10	
2.9 Response time / Release time	ms	typically 10 / typically 6	
2.10 Contact force NO / NC	cN	≥ 20 / ≥ 8	
2.14 Contact gap	mm	> 0,5 ²⁾	
3.0 Other			
3.1 Mechanical life	switching cycles	$\geq 10^7$	
3.2 Temperature range	°C	- 40 ... + 85	
3.3 Degree of protection, housing		Solder line proof RT II	
3.4 Test procedure		A (group mounting)	
3.5 Vibration resistance		10 ... 100 Hz; 0.35 mm Amplitude; 4 g max. IEC/EN 60068-2-6	
3.6 Climate resistance		40 / 085 / 04; A/B/D IEC/EN 60068-1	
3.7 Short circuit strength 1 kA / AC 250 V	AgNi or AgSnO ₂	6 AgL	IEC/EN 60947-5-1

¹⁾ Values for AgNi 10-contacts + 5 μ m Au

²⁾ over entire service life, even when under fault and at 1,3 x U_N

³⁾ Typical values

⁴⁾ Values for AgNi-contacts

⁵⁾ Values for AgSnO₂-contacts

Technical Data

3.8	Insulation acc. to IEC 60664-1, EN 50178		double and reinforced insulation
	Rated insulation voltage	AC V	250
	Pollution degree		2
	Overtoltage category		III
	Test voltage		
	Contact-coil (1 min)	AC kV eff.	≥ 4
	Contact-contact (1min)	AC kV eff.	≥ 4
	Open contact acc. to DIN EN 61810-1	AC kV eff.	1.5
	Transient voltage		
	Contact-coil (1.2 - 50 μs)	kV	≥ 6
	Clearance and creepage distances		
	Contact-coil	mm	≥ 8
	Contact-contact	mm	≥ 5.5
3.9	Weight	g	approx. 17
4.0 Packing			
4.1	on cardboard	piece	24
4.2	in case package	piece	240
5.0 Solder method			
5.1	Solder method /-temperature /-duration	°C / s	Wafer soldering / 260 / 5

Design Versions

U _N (DC V)	Voltage range (DC V)	Resistance at 20°C	AgNi10-contacts + 0,2 μm Au		AgNi10-contacts + 5 μm Au	
			OA 5667.12 2 C/O	OA 5667.16 1NO, 1NC	OA 5667.12 2 C/O	OA 5667.16 1NO, 1NC
6	4.5 ... 7.8	48	2861	2891	2871	2901
12	9.0 ... 15.6	183	2862	2892	2872	2902
24	18.0 ... 31.2	750	2863	2893	2873	2903
48	36.0 ... 62.4	3200	2864	2894	2874	2904
60	45.0 ... 78.0	4700	2865	2895	2875	2905
110	82.5 ... 143.5	15300	2866	2896	2876	2906

Ordering Example

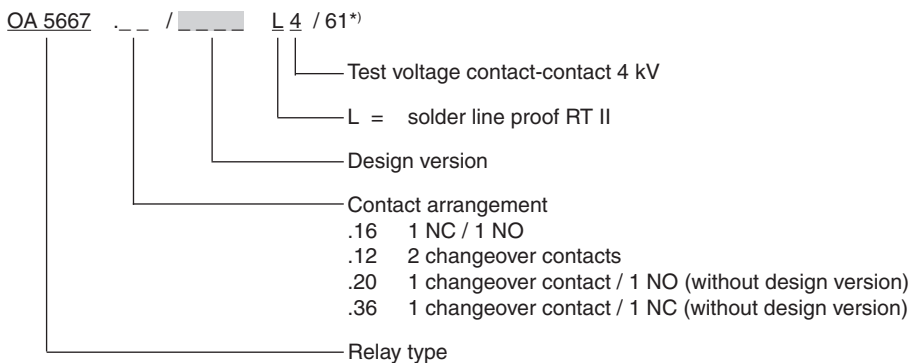

*) /61 cURus approval

Characteristics

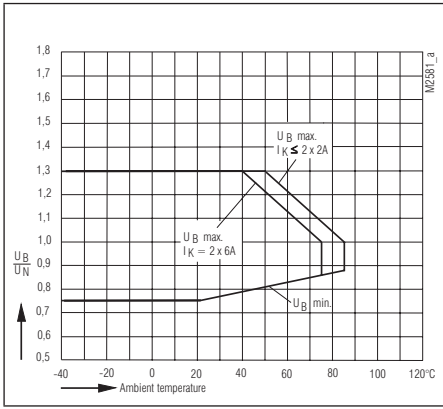

Operating voltage limit curve

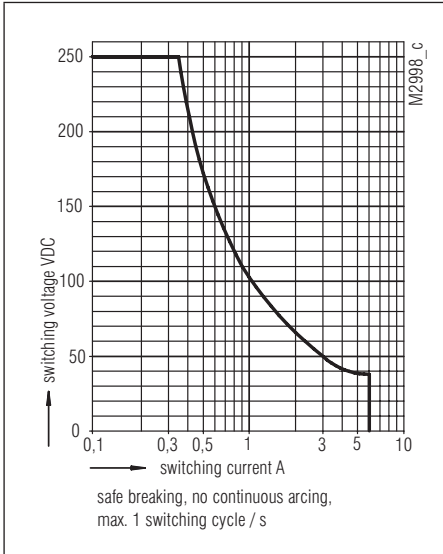

Limit curve for arc-free operation

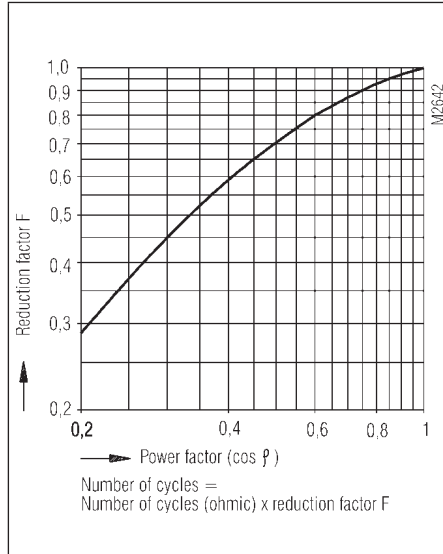

Reduction factor for inductive loads

Electrical life of the output contacts determined by
DIN EN 60947-5-1 / Annex C.3

M4727_a

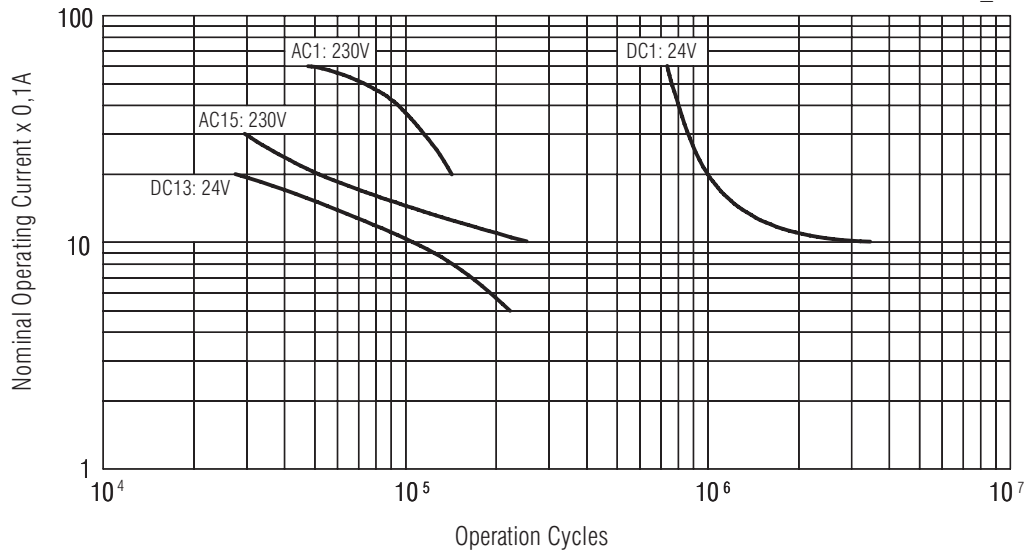

Drilling plan (solder side)

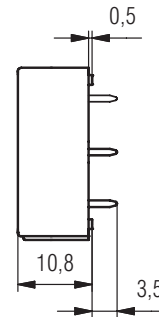
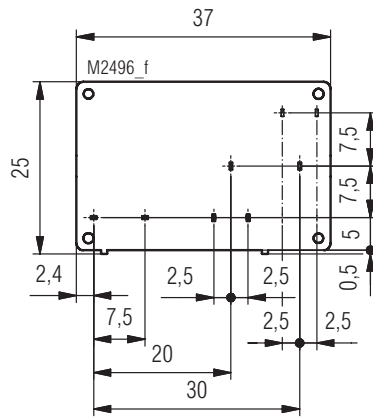
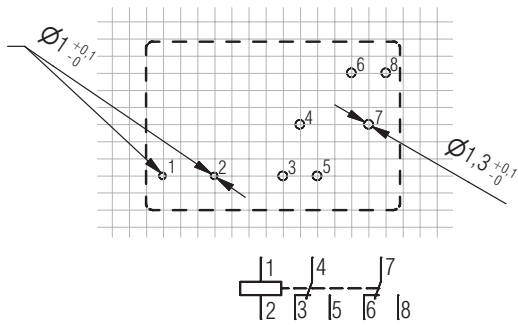

OA 5667.12/...L4
 OA 5667.20/...L4 contact 6 not fitted

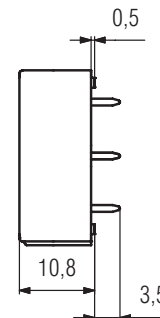
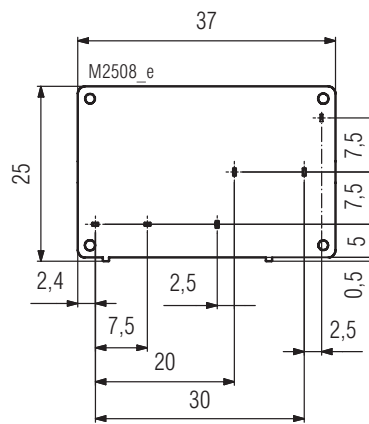
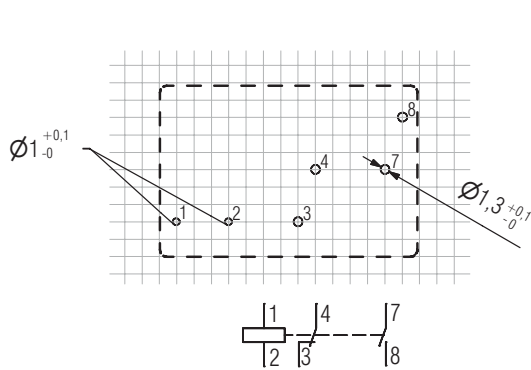

OA 5667.16/...L4

Connection for basic grid dimensions 2.5 mm as well as 2.54 mm according to IEC/EN 60097 and IEC 60326 average