

PCB-relay with 1 NO or 1 changeover contact.
The contacts of the remanence relays stay in position after a current pulse until a pulse in reverse direction resets the contacts.

- According to DIN EN 61810-1, DIN EN 60664-1
- Clearance and creepage distances:
contact - coil ≥ 5.5 mm
- High dielectric strength ≥ 4 kV
- High thermal continuous current $I_{th} = 5$ A
- High switching power AC 250 V / 5 A
- Compact size $V = 2.47$ cm³
- Very small volume **DIL model**, can be plugged into standard IC-socket
- Wash proof RT III

Applications

- Control technique
- Interface

Approvals and Markings



Technical Data

Relay type	OR 5691	
1.0 Relay coil		
1.1 Nominal voltage	DC V	4, 5, 6, 12, 20, 24, 48
1.2 Nominal consumption	W	0.7 (1u)
1.3 Test voltage coil/chassis	AC kV	≥ 2.5
1.4 Pulse length	ms	see diagram operate pulse length
1.5 Non operation voltage		$\leq 0.40 \times U_N$
1.6 Hold voltage		$\leq 0.025 \times U_N$ (opposite polarity of operating voltage)
1.7 Release voltage		see diagram reset time
1.8 Reset voltage		$\leq 0.18 \times U_N$ (opposite polarity of operating voltage)
1.9 max. permitted coil temperature	°C	120°C
1.10 Coil data		see page 4
1.11 Voltage range		$0.80 \dots 1.3 \times U_N$
1.12 Temperature resistance	k / W	
2.0 Contacts		
2.1 Contact arrangement		1 NO, 1 changeover contact
2.2 Contact material		AgSnO ₂ + 0.3 µm Au; AgNi + 0.3 µm Au
2.3 Rated insulation voltage	AC V	250
Switching voltage min./max.	V	AC/DC 10 / DC 120, AC 250 V
2.4 Limiting continuous current I_{th}	A	5
Switching current min./max.	A	0.01 ¹⁾ / 5
2.5 Switching power min./max.	VA	0.1 / 1 250
Switching power min./max.	W	0.1 / 120
2.6 Switching capacity to IEC/EN 60947-5-1		
AC 15	AC V/A	NC: 230 / 1 NO: 230 / 3
2.7 Electrical Life		at 1 s On, 1 s Off (see contacts service life)
at AC 230 V 1 A $\cos \varphi = 1$	switching cycles	5×10^5
at AC 230 V 5 A $\cos \varphi = 1$	switching cycles	1.5×10^5
2.8 Switching frequency max.	switching cycles / s	20
2.9 Response time / Release time	ms	typically ≤ 8 / (see diagram reset time)
2.10 Contact force NO / NC	cN	8
2.12 Contact model		spring contact
2.13 Contact resistance	mΩ	≤ 30 (measuring current 10 mA, measuring voltage 2 V DC)
2.14 Contact gap	mm	0.3 ... 0.4
2.15 Contact override	mm	≥ 0.3
2.16 Bouncing time		
(at U_N) NC	ms	≤ 8 (typisch 5.5) at $U_{AB} = 0.3 \times U_N$
(at U_N) NO	ms	≤ 4.2 (typisch 2.6) at $U_{AN} = U_N$
2.17 Impulse with stand voltage	kV	2; 1.2/50
2.18 Capacity		
between open contacts	pF	≤ 2 (typically 1.5)
between contact and coil	pF	≤ 9 (typically 7)

¹⁾ Typical values

Technical Data

3.0 Other

3.1	Mechanical life	switching cycles	≥ 10 ⁸
3.2	Temperature range	°C	- 40 ... + 65
3.3	Degree of protection		Wash proof RT III
3.5	Vibration resistance		10 ... 55 Hz; 1.2 mm amplitude; 10 g max. IEC/EN 60068-2-6
3.6	Climate resistance		20 / 065 / 04 (climate category); A/B/D IEC/EN 60068-1
3.8	Insulation according to IEC 60664-1		
	Rated insulation voltage	AC V	250
	Pollution degree		3
	Overvoltage category		III
	Test voltage		
	contact-coil (1 min)	AC kV eff.	≥ 4
	Clearance and creepage distances		
	Contact- Coil	mm	≥ 5.5 (safe separation acc. to EN 50178)
3.9	Weight	g	approx. 5
3.10	Dimensions	mm	see dimensions
3.13	Mounting direction		free
3.14	Operating mode		100 % duty cycle
3.15	Sealing		epoxy resin

4.0 Packing

4.1	on cardboard in slipcase	piece	100
4.2	in case package	piece	1000

5.0 Solder method

5.1	Solder method /-temperature /-duration	°C / s	Wafe soldering / 260 / 5
-----	--	--------	--------------------------

Design Versions

U _N DC	Resistance at 20°C Ω ± 10%	AgNi 0,15 + 0.3 μm Au	
		OR 5691.11/..	OR 5691.01/..
4.5	27	7521	7531
6	50	7522	7532
12	200	7523	7533
20	600	7524	7534
24	820	7525	7535
48	3300	7526	7536

Ordering Example

OR 5691 . . . / . . . / 61*)

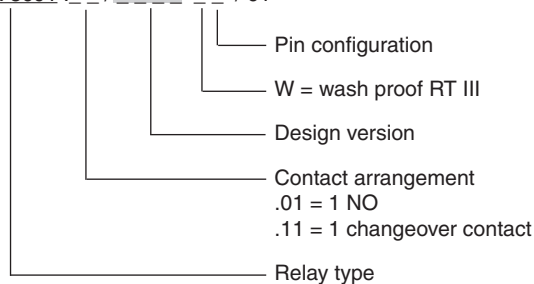

*) /61 cURus approval

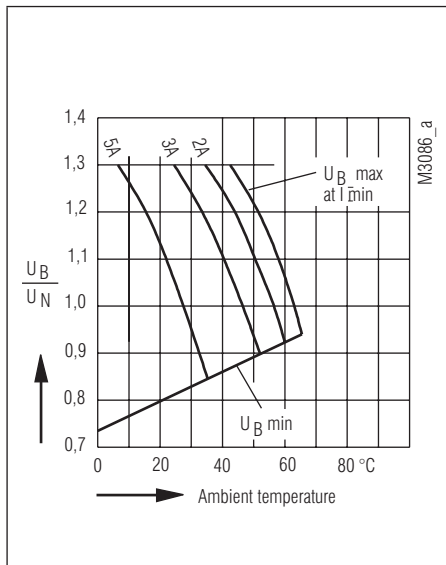

Operating voltage limit curve

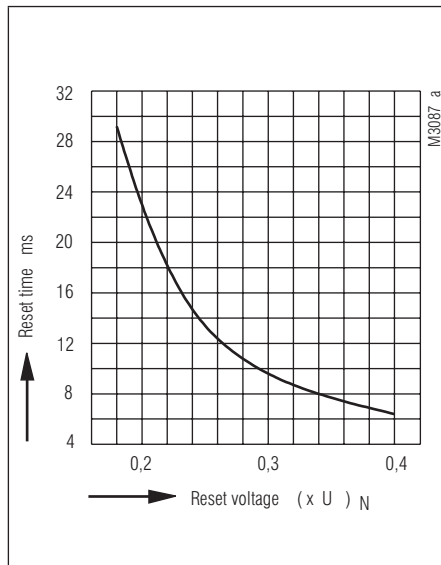

Reset time

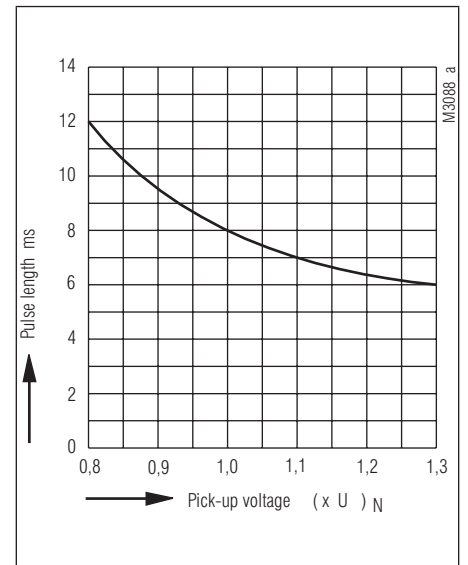

Response-Impulse length

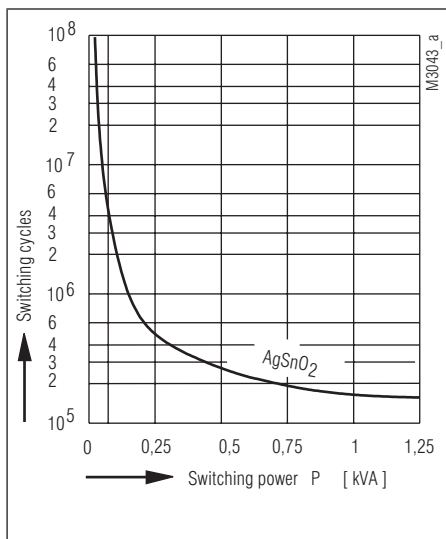

Contact service life

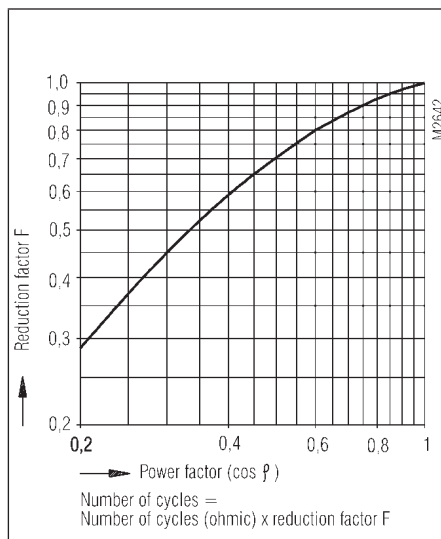

Reduction factor for inductive loads

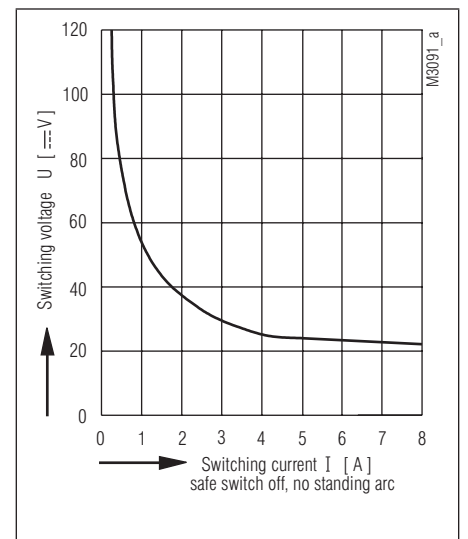

Limit curve for arc-free operation

Dimensions, Pin Configuration, Connection Diagrams

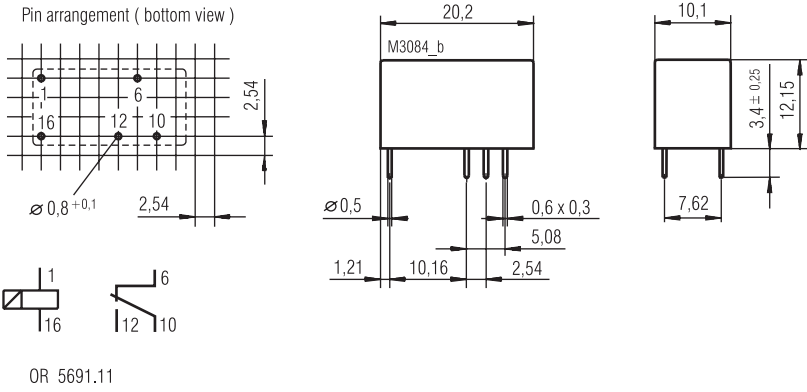
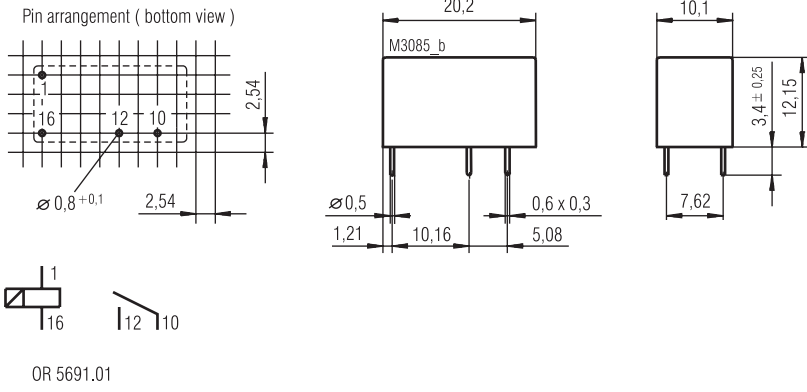

Connections for basic grid dimensions 2.5 mm as well as 2.54 mm according to IEC/EN 60 097 and IEC 60 326 average.
Pin distance tolerance measured at the pin ends ± 0.3 mm. Dimensions are valid for untinned state.