

Presentation in the deactivated condition:
1st key inserted; 2nd key and actuator removed

STS/K-System Benefits

- EU-Test certificate according to the directive 2006/42/EG, annex IX
- For safety applications up to PLe/Category 4 according to EN ISO 13849-1
- Modular and expandable system
- Rugged composite version of stainless steel and plastic design
- Wireless mechanical safeguarding
- Combines the benefits of safety switch, solenoid locking and key transfer in a single system
- Easy installation through comprehensive accessories
- Protection against lock-in
- Coding level low, medium, high according to DIN EN ISO 14119:2014-03

Features

- The unit is particularly suitable for applications with:
- Full body access (lock-in danger)
- Optional key removal
- Several secured entries
- Rugged ambient conditions
- This units are also available in stainless steel

Approvals and Markings



Function

Mechanical solenoid locking for separating guards with forced key entry and forced key removal as well as electrical monitoring function.

Application

To secure separating guards such as safety gates and hoods in machine and plant engineering.

Design and Operation

Attention!



Hazards must be ruled out before the movable part of the guard can then be opened! and the dangerous location can be reached!

The STS/K solenoid locking unit is to be integrated into a system and connected with a control unit so that the hazardous machine can run only when the guard is locked and closed.

After entering a first key the second key can be removed. The first key is blocked and the actuator released after removing the second key. The second key is blocked when the access is opened and the actuator is thus removed from actuator module B/K. This disables a restart of the plant. Only after the access is locked, the actuator and then the second key were returned to their starting position can the first key be removed again and the solenoid locking is activated.

RXK11M/K und RX11BM/K are used in the system in connection with additional STS/K units and SAFEMASTER products. The first key to be entered may originate from these units (e.g. release through upstream solenoid locking ZRH01BM/K in connection with a speed monitor UH 5947 or standstill monitor LH 5946). The second key to be removed can serve as protection against lock-in or for the operating release of additional units (e.g. M10BM/K, M11BM/K, M12M/K, M10B01M/K). On the base unit RX11BM/K the key can be assigned to a person with access rights.

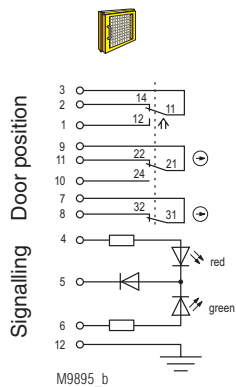

Fig. 1:
Locked while activated:
Actuator inserted,
2nd key inserted,
Actuator removed,
1st key removed
Door closed

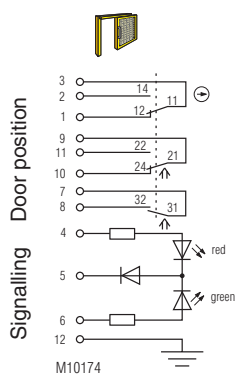

Fig. 2:
Lock deactivated:
2nd key removed,
Actuator removed,
1st key inserted
Door open

Switching logic

			Fig. 1	Fig. 2
Door contacts	3	2		
	3	1		
	9	11		
	9	10		
	7	8		

closed
 open

Enclosure: PA + GF
 Internal parts and inserting slots: Stainless steel V4A / AISI 316 / AISI 630
 Degree of protection: IP 65
 Temperature range: - 25 °C to + 40 °C
 Storage temperature: - 25 °C to + 60 °C
 Mechanical principle: Rotating axis with redundant actuator
 Connection method: Cage clamp terminals
 min. connection cross-section: 0.25 mm²
 max. connection cross-section: 0.75 mm²
 Cable entry: 1 x M20 x 1.5
 B10_d: 2 x 10⁶ switching cycles
 Electrical service life: 5 x 10⁶ switching cycles
 Locking force: min. 2000 N
 min. operating speed: 100 mm/s
 max. operating speed: 250 mm/s
 max. switching frequency: 360/h
 Nominal voltage U_N: AC/DC 24 V
 Nominal voltage range: 0.85 ... 1.1 U_N
 Power consumption: 0.3 W
 Rated impulse voltage: 0.8 kV
 Rated insulation voltage: ≤ 50 V
 Overvoltage category: III
 Pollution degree: 2
 max. operating current: 2 A
 Contacts: 1 NC contact, 2 antivalent changeover contacts

Switching principle: Changeover contact with forced-opening snap-action switch

Utilization category of switching elements
 to AC 15: 1 A
 to DC 13: 0.5 A
 Short circuit strength, max. fusing: 2 A gG
 Rated conditional short circuit current: 1000 A
 Contact material: Ag / AgSnO₂
 Indicator: LED red/green, separate selection possible

Test principles: EN ISO 13849-1:2008
 DIN EN ISO 14119:2014-03
 EN 60947-5-1:2005
 GS-ET-15:02.2011
 GS-ET-19:02-2011
 GS-ET-31:02-2010

Intended use: up to max. cat. 4, PL e according to EN ISO 13849-1
 according to DIN EN 50041
 IEC EN 60947-5-1 Appendix K

Mounting: according to DIN EN 50041
 Contact elements: IEC EN 60947-5-1 Appendix K

Additional requirement for cat. 4 structure (as single unit): Add 2nd actuator module

Logic and output	cat. 2	cat. 3	cat. 4
RX11BM/K:	90 %	90 %	
RXK11M/K:	90 %	90 %	
RX11BBM/K:	90 %	90 %	99 %
RXKK11M/K:	90 %	90 %	99 %

Protection against faults of common cause: see table in STS design guide
 Repair and replacement: by manufacturer only
 Test intervals:
 for PL a to d: min. once a year
 for PL e: min. once a month

ATTENTION !



To avoid wrong usage (e.g. by overload, mounting position or usage in acid, alkaline or other hostile ambient conditions) the limitations of the product have to be observed. Please check in advance if your application requires the usage of the more robust stainless steel model of SAFE-MASTER STS. The requirements of the mounting and operating instruction must be fulfilled.

Ordering Example

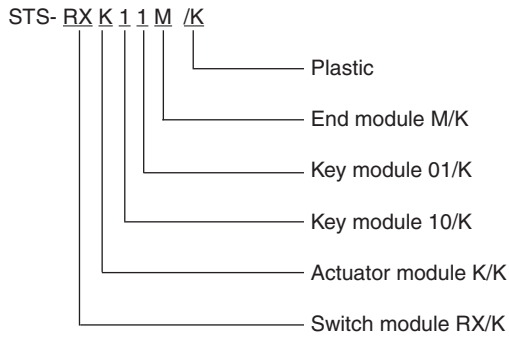

Ordering Example

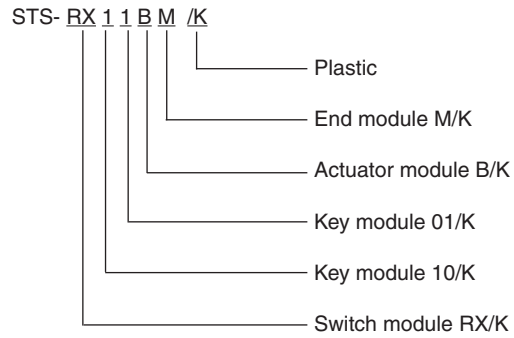

Variants and Combination Options

Because of their modular design the basic units of the SAFEMASTER STS/K System can be combined and expanded according to customer requests. This allows for a variety of possible units and functions.

Overview of the basic units

Functions	Safety switches design type 2	Safety switches design type 2 with solenoid lock	Mechanical units design type 2	Mechanical units with electrical monitoring	Mechanical units with electrical release
Units with standard function	SXBM/K	ZRHBM/K	M10BM/K	RXK01M/K RX10BM/K	YRXKM/K YRXK01M/K
Units with mechanical lock and forced key extraction	SX01BM/K	ZRH01BM/K	M11BM/K	RXK11M/K RX11BM/K	YRX10BM/K YRX11BM/K
Units with optional key extraction	SXB01M/K	ZRHB01M/K	M10B01M/K	RX10B01M/K RX10K01M/K	YRX10B01M/K
Units without actuator	SX01M/K	ZRH01M/K	M12M/K	RX11M/K	YRX11M/K

For additional information refer to the data sheets of the individual modules and other basic units.

Data sheets

Switching module RX/K
Key module 01/K / 10/K
Actuator module B/K
Actuator module K/K
End module M/K



Take advantage of the advice of the **E. DOLD & SÖHNE KG** specialists regarding the choice of units and combination of a system.

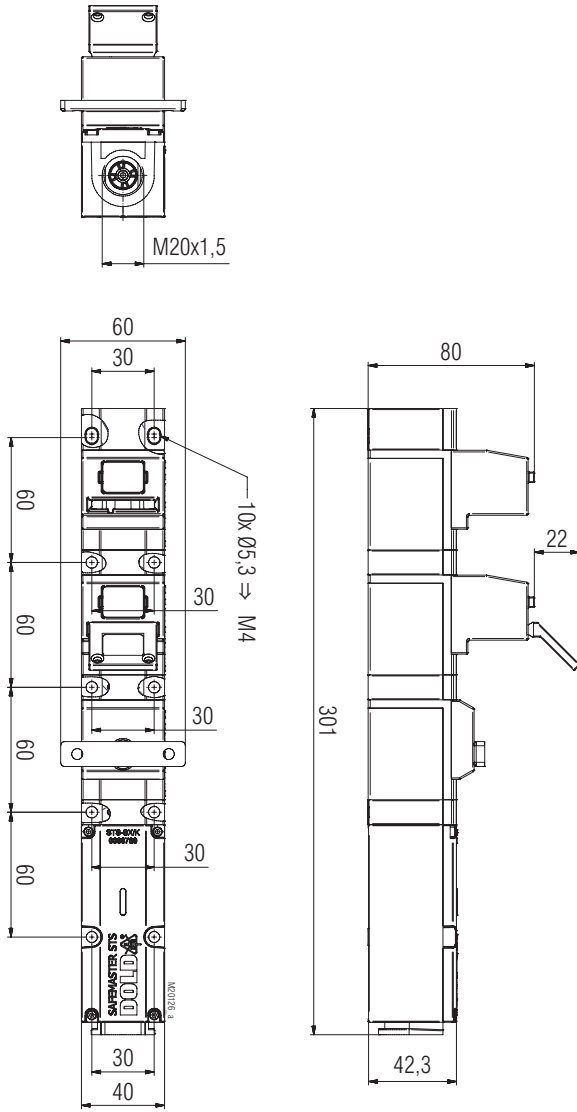

RXK11M/K
Clearance tolerances ± 2%

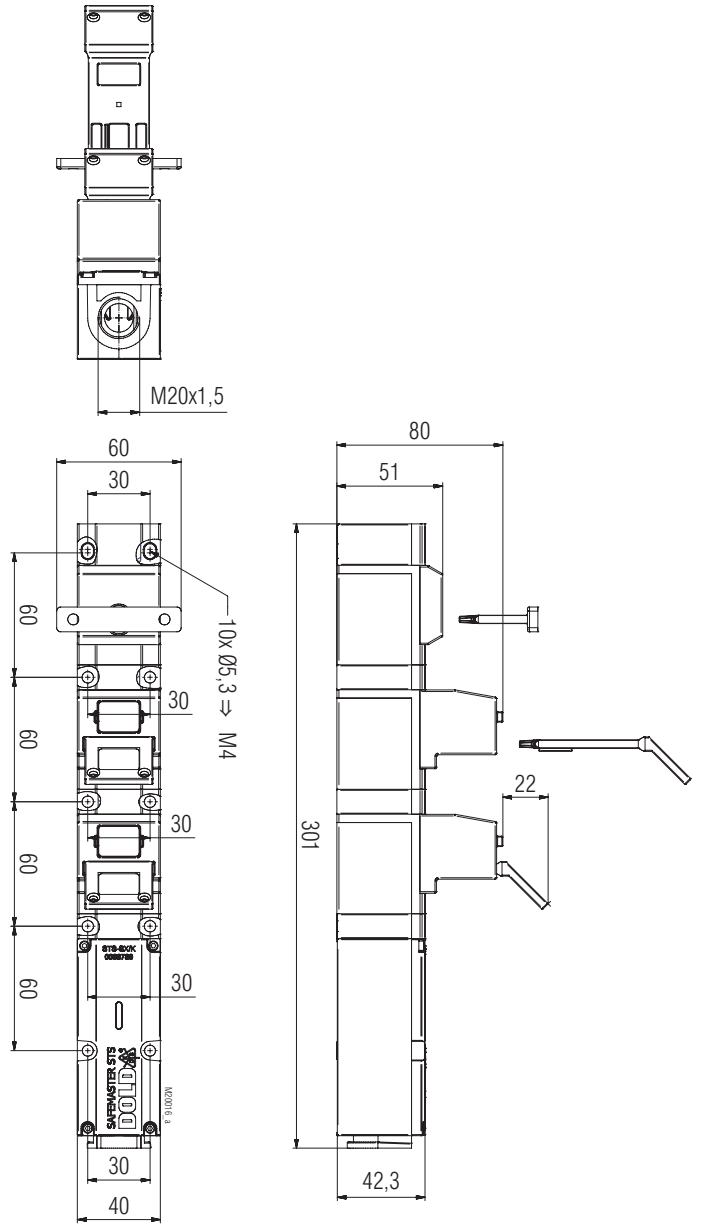

RX11BM/K
Clearance tolerances ± 2%

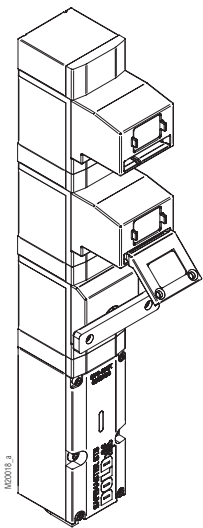

RXK11M/K

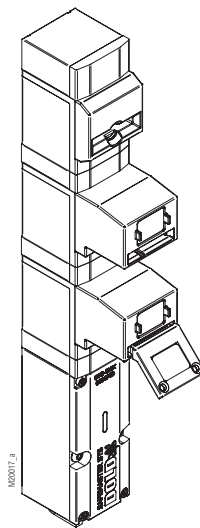

RX11BM/K