

Operating Instructions

Proline Promag 53

FOUNDATION Fieldbus

Electromagnetic flowmeter

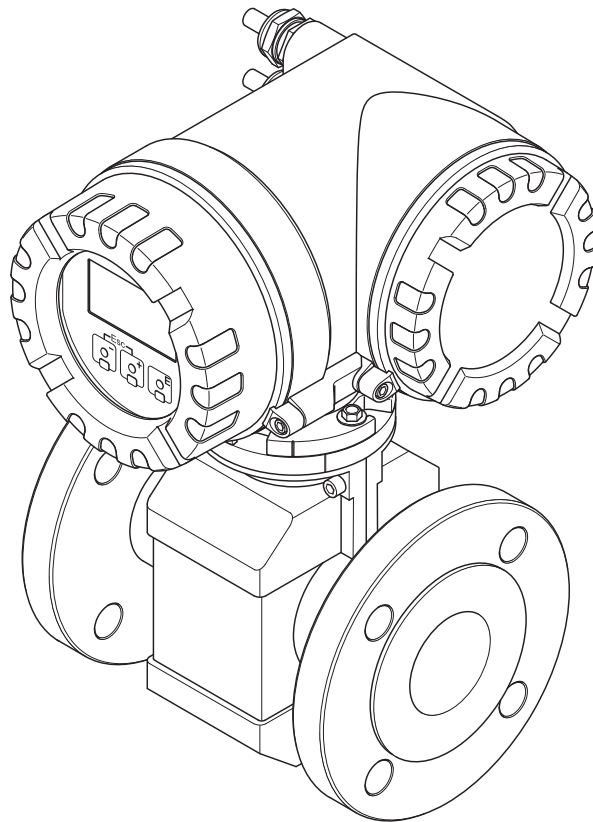

Table of contents

1	Safety instructions	4	8.3	Communication-specific accessories	79
1.1	Designated use	4	8.4	Service-specific accessories	79
1.2	Installation, commissioning and operation	4	9	Troubleshooting	80
1.3	Operational safety	4	9.1	Troubleshooting instructions	80
1.4	Return	5	9.2	System/process error messages	84
1.5	Notes on safety conventions and icons	5	9.3	Process errors without a message	90
2	Identification	6	9.4	Spare parts	91
2.1	Device designation	6	9.5	Return	99
2.2	Certificates and approvals	9	9.6	Disposal	99
2.3	FOUNDATION Fieldbus device certification	9	9.7	Software history	99
2.4	Registered trademarks	9	10	Technical data	100
3	Installation	10	10.1	Technical data at a glance	100
3.1	Incoming acceptance, transport and storage	10	Index	124	
3.2	Installation conditions	12			
3.3	Installation	20			
3.4	Post-installation check	40			
4	Wiring	41			
4.1	FOUNDATION Fieldbus cable specification	41			
4.2	Shielding and grounding	43			
4.3	Connecting the remote version	44			
4.4	Connecting the measuring unit	49			
4.5	Potential equalization	53			
4.6	Degree of protection	55			
4.7	Post-connection check	56			
5	Operation	57			
5.1	Quick operation guide	57			
5.2	Local display	58			
5.3	Brief Operating Instructions for the function matrix	61			
5.4	Error messages	63			
5.5	Operating programs	64			
5.6	FOUNDATION Fieldbus hardware settings	66			
6	Commissioning	67			
6.1	Function check	67			
6.2	Switching on the measuring device	67			
6.3	Commissioning using FOUNDATION Fieldbus	68			
6.4	Adjustment	74			
6.5	Data storage devices	76			
7	Maintenance	77			
7.1	Exterior cleaning	77			
7.2	Seals	77			
8	Accessories	78			
8.1	Device-specific accessories	78			
8.2	Accessories specific to measuring principle	78			

1 Safety instructions

1.1 Designated use

The measuring device described in this Operating Manual is to be used only for measuring the flow rate of conductive fluids in closed pipes.

All fluids (including demineralized water) can be metered, provided they have a minimum conductivity of 5 $\mu\text{S}/\text{cm}$, for example:

- acids, alkalis, pastes, paps, pulps, black liquor, green liquor
- drinking water, wastewater, sewage sludge
- milk, beer, wine, mineral water, yoghurt, molasses, fruit mash

Incorrect use or use other than that designated may result in the operational safety of the measuring devices being suspended. The manufacturer accepts no liability for damages resulting from this.



1.2 Installation, commissioning and operation

Note the following points:

- Installation, connection to the electricity supply, commissioning and maintenance of the device must be carried out by trained, qualified specialists authorized to perform such work by the facility's owner-operator. The specialist must have read and understood these Operating Instructions and must follow the instructions they contain.
- The device must be operated only by persons authorized and trained by the system operator. Strict compliance with the instructions in the Operating Instructions is mandatory.
- Endress+Hauser is willing to assist in clarifying the chemical resistance properties of parts wetted by special fluids, including fluids used for cleaning. However, small changes in temperature, concentration or the degree of contamination in the process can result in changes to the chemical resistance properties. For this reason, Endress+Hauser does not accept any responsibility with regard to the corrosion resistance of materials wetted by fluids in a specific application. The user is responsible for the choice of wetted materials with regard to their in-process resistance to corrosion.
- If welding work is performed on the piping system, do not ground the welding appliance through the flowmeter.
- The installer must ensure that the measuring system is correctly wired in accordance with the wiring diagrams. The transmitter must be grounded, except in cases where special protective measures have been taken (e.g. galvanically isolated power supply SELV or PELV).
- Always note the regulations applicable in your country to the operation, maintenance and repair of electrical devices. Special instructions relating to the device can be found in the relevant sections of the documentation.

1.3 Operational safety

Note the following points:

- Measuring systems for use in hazardous environments are accompanied by separate "Ex documentation", which is an integral part of these Operating Instructions. Strict compliance with the installation instructions and ratings as stated in this supplementary documentation is mandatory. Depending on the approval and certification agency, the relevant symbol is depicted on the front page of the supplementary documentation on Ex ratings (e.g.  Europe,  USA,  Canada).
- The measuring device meets the general safety requirements according to EN 61010-1 and the EMC requirements according to IEC/EN 61326 in addition to the NAMUR recommendations NE 21, NE 43 and NE 53.

- Due to the performance rate in the electronic components, the external housing surfaces are heated to a maximum of 10 K. When conducting hot media through the measuring tube, the surface temperature of the housing increases. Particularly in the case of the sensor, temperatures close to the fluid temperature must be anticipated. In the event of elevated fluid temperatures, please ensure that fire protection is in place.
- The manufacturer reserves the right to modify technical data without prior notice. Your Endress+Hauser distributor will supply you with current information and updates to these Operating Instructions.

1.4 Return

- Do not return a measuring device if you are not absolutely certain that all traces of hazardous substances have been removed, e.g. substances which have penetrated crevices or diffused through plastic.
- Costs incurred for waste disposal and injury (burns, etc.) due to inadequate cleaning will be charged to the owner-operator.

1.5 Notes on safety conventions and icons

The devices are designed and tested to meet state-of-the-art safety requirements, and have left the factory in a condition in which they are safe to operate. The devices comply with the applicable standards and regulations in accordance with EN 61010 -1 "Protection Measures for Electrical Equipment for Measurement, Control, Regulation and Laboratory Procedures". The devices can, however, be a source of danger if used incorrectly or for other than the designated use.

For this reason, always pay particular attention to the safety instructions indicated in these Operating Instructions by the following icons:



Warning!

"Warning" indicates an action or procedure which, if not performed correctly, can result in personal injury or a safety hazard. Comply strictly with the instructions and proceed with care.



Caution!

"Caution" indicates an action or procedure which, if not performed correctly, can result in incorrect operation or destruction of the device. Comply strictly with the instructions.



Note!

"Note" indicates an action or procedure which, if not performed correctly, can have an indirect effect on operation or trigger an unexpected response on the part of the device.

2 Identification

2.1 Device designation

The flow measuring system consists of the following components:

- Promag 53 transmitter
- Promag E/H/P/W sensors

Two versions are available:

- Compact version: transmitter and sensor form a single mechanical unit
- Remote version: transmitter and sensor are installed separately

2.1.1 Nameplate of the transmitter

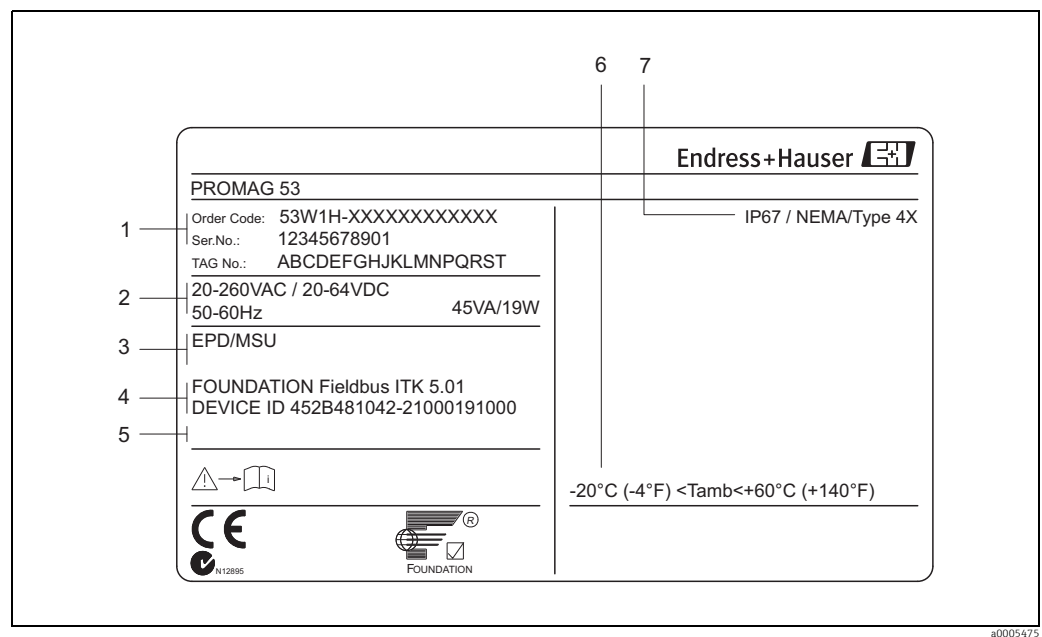

Fig. 1: Nameplate specifications for the "Promag 53" transmitter (example)

- 1 Order code/serial number: See the specifications on the order confirmation for the meanings of the individual letters and digits
- 2 Power supply/frequency
Power consumption
- 3 Additional functions and software
 - EPD: with empty pipe detection electrode
 - ECC: with electrode cleaning
- 4 FOUNDATION Fieldbus: equipped with FOUNDATION Fieldbus H1 interface
ITK 5.01: certified by the Fieldbus Foundation; Interoperability Test Kit, revision 5.01
DEVICE ID: FOUNDATION Fieldbus device identification
- 5 Reserved for additional information on special products
- 6 Permitted ambient temperature range
- 7 Degree of protection

2.1.2 Nameplate of the sensor

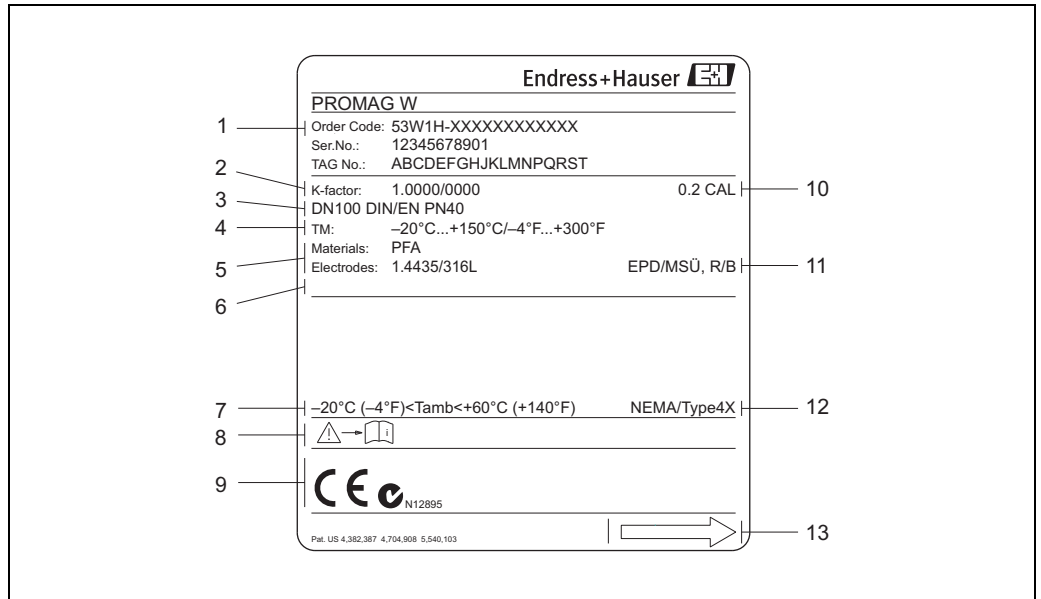

Fig. 2: Nameplate specifications for the "Promag W" sensor (example)

- 1 Order code/serial number: See the specifications on the order confirmation for the meanings of the individual letters and digits
- 2 Calibration factor with zero point
- 3 Nominal diameter/nominal pressure
- 4 Medium temperature range
- 5 Materials: lining/measuring electrode
- 6 Reserved for additional information on special products
- 7 Permitted ambient temperature range
- 8 Please comply with the Operating Instructions
- 9 Reserved for additional information on device version (approvals, certificates)
- 10 Calibration tolerance
- 11 Additional information
 - EPD: with empty pipe detection electrode
 - R/B: with reference electrode
- 12 Degree of protection
- 13 Flow direction

2.1.3 Nameplate for connections

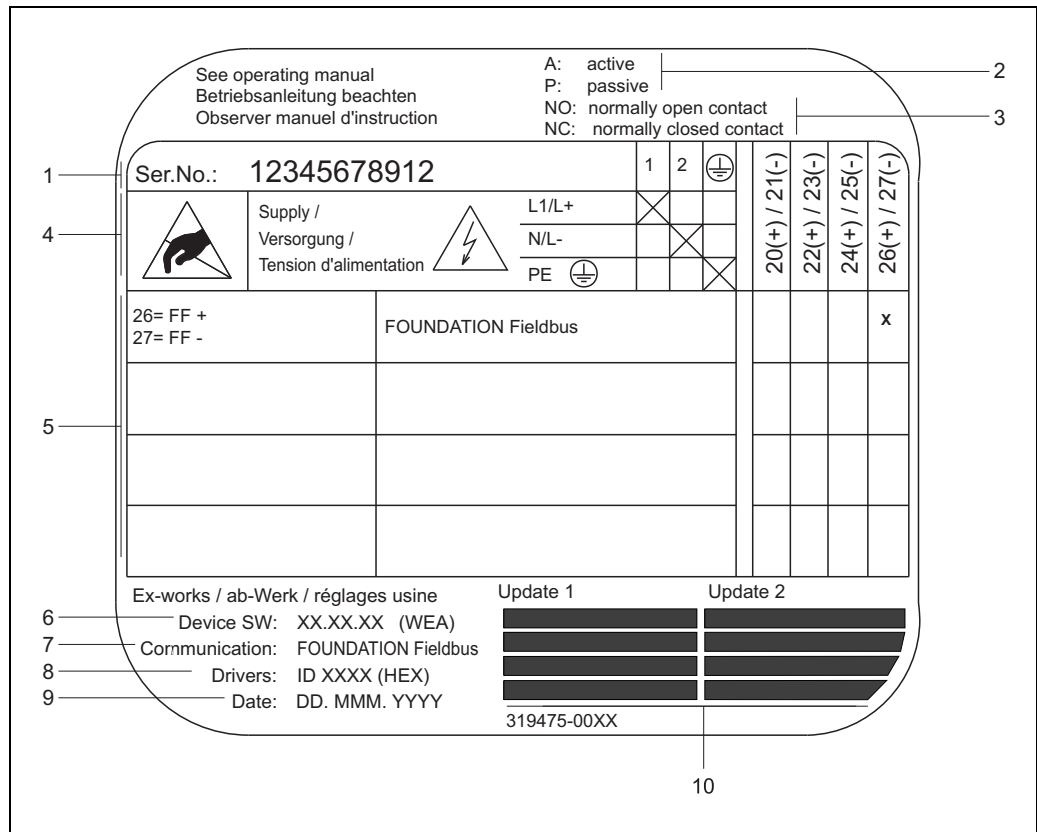

Fig. 3: Nameplate specifications for Proline transmitter connections (example)

- 1 Serial number
- 2 Possible configuration of current output
- 3 Possible configuration of relay contacts
- 4 Terminal assignment, cable for power supply
 Terminal no. 1:
 - L1 for AC, L+ for DC
 Terminal no. 2:
 - N for AC, L- for DC
- 5 Signals present at inputs and outputs, possible configurations and terminal assignment
- 6 Version of device software currently installed (incl. language group)
- 7 Type of communication installed
- 8 Information on current communication software (Device Revision, Device Description)
- 9 Date of installation
- 10 Current updates to data specified in points 6 to 9

2.2 Certificates and approvals

The devices are designed and tested to meet state-of-the-art safety requirements in accordance with sound engineering practice. They have left the factory in a condition in which they are safe to operate. The devices comply with the standards EN 61010 -1 "Protection Measures for Electrical Equipment for Measurement, Control, Regulation and Laboratory Procedures" and with the EMC requirements of IEC/EN 61326. The measuring system described in these Operating Instructions therefore complies with the legal requirements of the EU Directives. Endress+Hauser confirms this by affixing the CE mark to it and by issuing the CE Declaration of Conformity. The measuring system is in conformity with the EMC requirements of the "Australian Communications and Media Authority (ACMA)".

2.3 FOUNDATION Fieldbus device certification

The flowmeter has passed all the test procedures implemented and has been certified and registered by the Fieldbus Foundation. The device thus meets all the requirements of the following specifications:

- Certified to FOUNDATION Fieldbus specification
- The flowmeter meets all the specifications of the FOUNDATION Fieldbus H1.
- Interoperability Test Kit (ITK), revision 5.01: The device can also be operated in conjunction with other manufactures certified devices.
- Physical Layer Conformance Test by Fieldbus Foundation

2.4 Registered trademarks

KALREZ® and VITON®

Registered trademarks of E.I. Du Pont de Nemours & Co., Wilmington, USA

TRI-CLAMP®

Registered trademark of Ladish & Co., Inc., Kenosha, USA

FOUNDATION™ Fieldbus

Registered trademark of the Fieldbus Foundation, Austin, USA

HistoROM™, S-DAT®, T-DAT™, F-CHIP®, FieldCare®, Fieldcheck®, Applicator®

Registered or registration-pending trademarks of Endress+Hauser Flowtec AG, Reinach, CH

3 Installation

3.1 Incoming acceptance, transport and storage

3.1.1 Incoming acceptance

On receipt of the goods, check the following points:

- Check the packaging and the contents for damage.
- Check the shipment, make sure nothing is missing and that the scope of supply matches your order.

3.1.2 Transport

The following instructions apply to unpacking and to transporting the device to its final location:

- Transport the devices in the containers in which they are delivered.
- Do not remove the protection plates or caps on the process connections until you are ready to install the device. This is particularly important in the case of sensors with PTFE linings.

Special notes on flanged devices



Caution!

- The wooden covers mounted on the flanges before the device leaves the factory protect the linings on the flanges during storage and transportation. Do not remove these protection plates until *immediately before* the device is installed in the pipe.
- Do not lift flanged devices by the transmitter housing or, in the case of the remote version, by the connection housing.

Transporting flanged devices $DN \leq 300$ (12")

Use webbing slings slung round the two process connections. Do not use chains, as they could damage the housing.



Warning!

Risk of injury if the measuring device slips. The center of gravity of the assembled measuring device might be higher than the points around which the slings are slung. At all times, therefore, make sure that the device does not unexpectedly turn around its axis or slip.

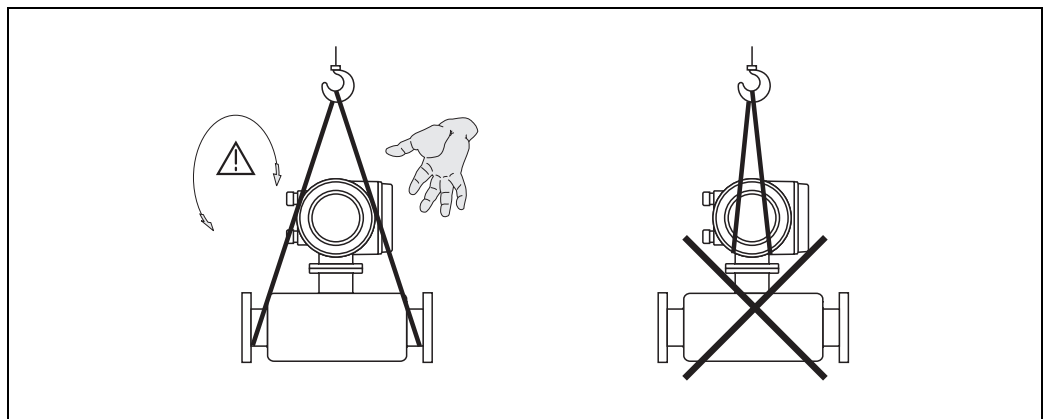

Fig. 4: Transporting sensors with $DN \leq 300$ (12")

a0004294

Transporting flanged devices DN > 300 (12")

Use only the metal eyes on the flanges for transporting the device, lifting it and positioning the sensor in the piping.



Caution!

Do not attempt to lift the sensor with the tines of a fork-lift truck beneath the metal casing. This would buckle the casing and damage the internal magnetic coils.

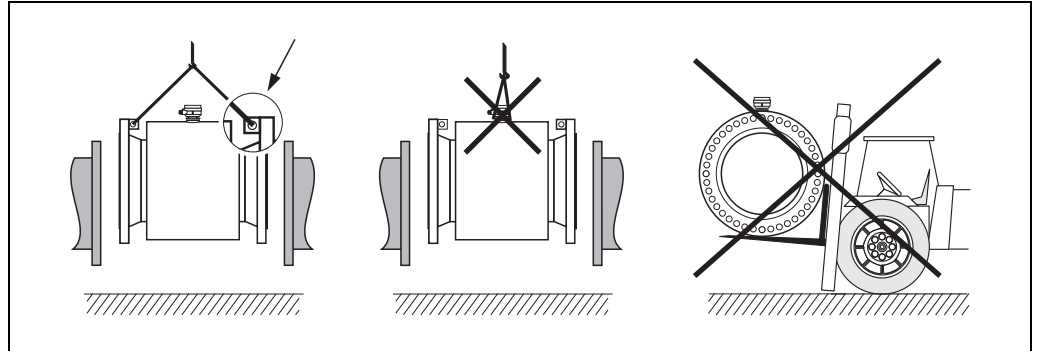

Fig. 5: Transporting sensors with DN > 300 (12")

3.1.3 Storage

Note the following points:

- Pack the measuring device in such a way as to protect it reliably against impact for storage (and transportation). The original packaging provides optimum protection.
- The storage temperature corresponds to the operating temperature range of the measuring transmitter and the appropriate measuring sensors → 104.
- The measuring device must be protected against direct sunlight during storage in order to avoid unacceptably high surface temperatures.
- Choose a storage location where moisture does not collect in the measuring device. This will help prevent fungus and bacteria infestation which can damage the lining.
- Do not remove the protection plates or caps on the process connections until you are ready to install the device. This is particularly important in the case of sensors with PTFE linings.

3.2 Installation conditions

3.2.1 Dimensions

All the dimensions and lengths of the sensor and transmitter are provided in the separate documentation "Technical Information".

3.2.2 Mounting location

The accumulation of air or gas bubbles in the measuring tube could result in an increase in measuring errors.

Avoid the following locations:

- At the highest point of a pipeline. Risk of air accumulating.
- Directly upstream from a free pipe outlet in a vertical pipeline.

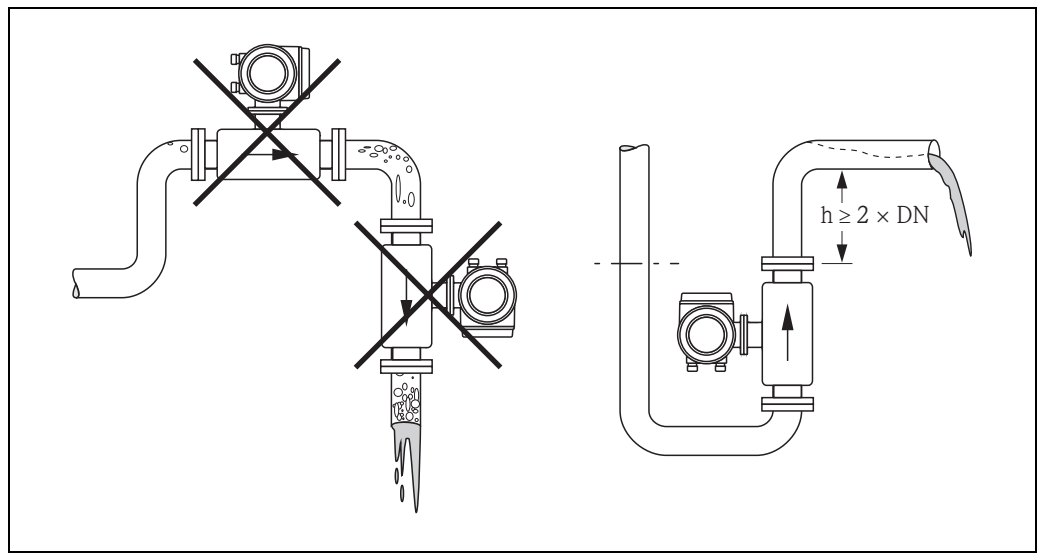

Fig. 6: Mounting location

Installing pumps

Do not install the sensor on the intake side of a pump. This precaution is to avoid low pressure and the consequent risk of damage to the lining of the measuring tube. Information on the lining's resistance to partial vacuum → 109.

It might be necessary to install pulse dampers in systems incorporating reciprocating, diaphragm or peristaltic pumps. Information on the measuring system's resistance to vibration and shock → 105.

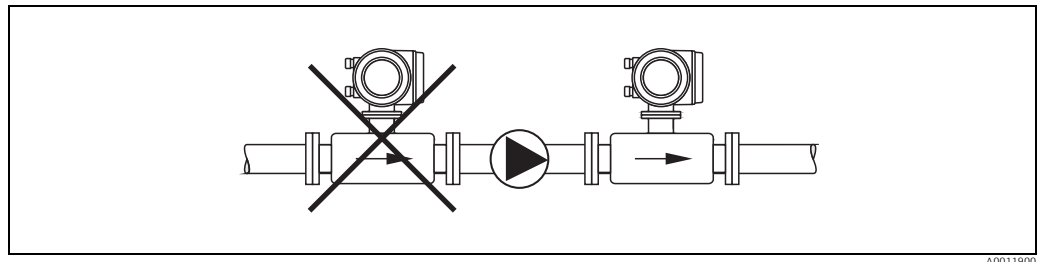

Fig. 7: Installing pumps

Partially filled pipes

Partially filled pipes with gradients necessitate a drain-type configuration. The Empty Pipe Detection function offers additional protection by detecting empty or partially filled pipes →

74.

**Caution!**

Risk of solids accumulating. Do not install the sensor at the lowest point in the drain. It is advisable to install a cleaning valve.

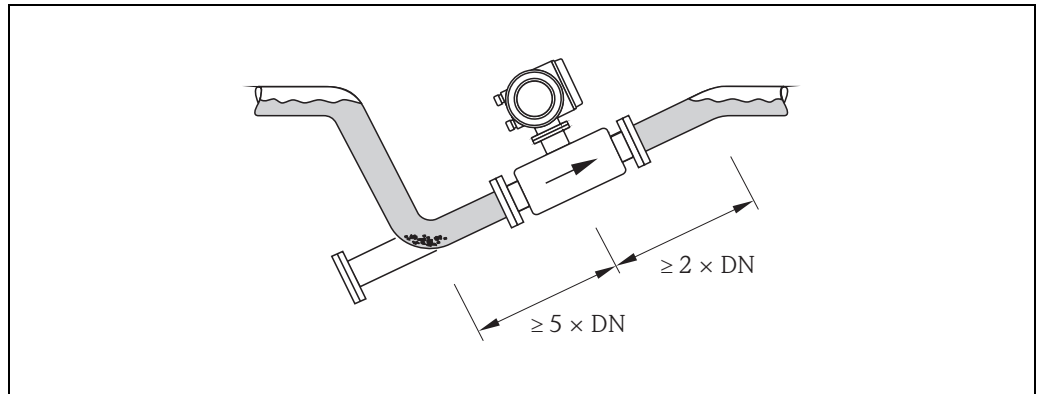

Fig. 8: Installation in partially filled pipe

A0011901

Down pipes

Install a siphon or a vent valve downstream of the sensor in down pipes longer than 5 m (16 ft). This precaution is to avoid low pressure and the consequent risk of damage to the lining of the measuring tube. This measure also prevents the system losing prime, which could cause air inclusions.

Information on the lining's resistance to partial vacuum → 109

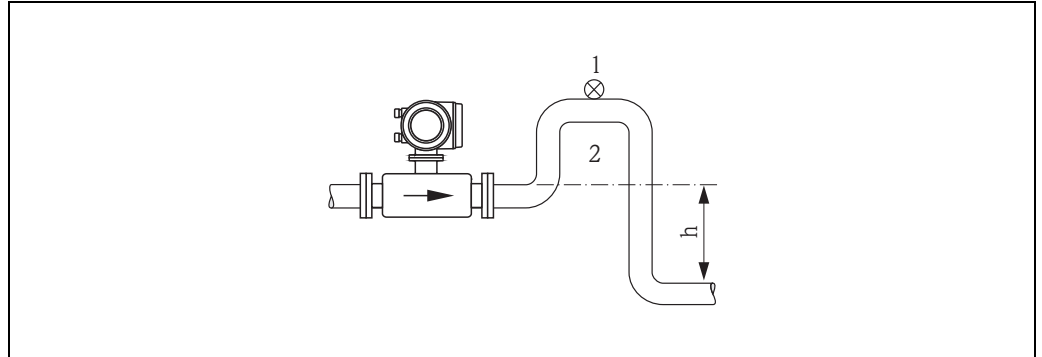

Fig. 9: Measures for installation in a down pipe ($h > 5 \text{ m} / 16 \text{ ft}$)

- 1 Vent valve
- 2 Siphon

A0011902

3.2.3 Orientation

An optimum orientation position helps avoid gas and air accumulations and deposits in the measuring tube. Promag, nevertheless, supplies a range of functions and accessories for correct measuring of problematic fluids:

- Electrode Cleaning Circuitry (ECC) to prevent electrically conductive deposits in the measuring tube, e.g. for fluids causing buildup (see "Description of Device Functions" manual).
- Empty Pipe Detection (EPD) ensures the detection of partially filled measuring tubes or in the case of degassing fluids → 74.

Vertical orientation

A vertical orientation is ideal in the following cases:

- For self-emptying piping systems and when using empty pipe detection.
- For sludge containing sand or stones and where the solids cause sedimentation.

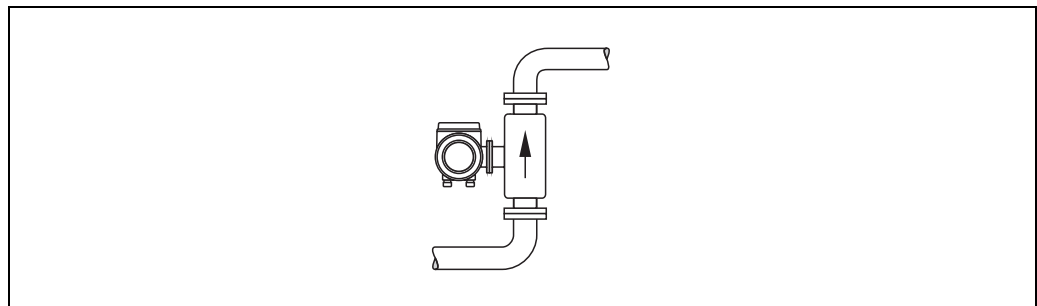

A0011903

Fig. 10: Vertical orientation

Horizontal orientation

The measuring electrode plane should be horizontal. This prevents brief insulation of the two electrodes by entrained air bubbles.



Caution!

Empty Pipe Detection functions correctly with the measuring device installed horizontally only when the transmitter housing is facing upward (see diagram). Otherwise there is no guarantee that Empty Pipe Detection will respond if the measuring tube is only partially filled.

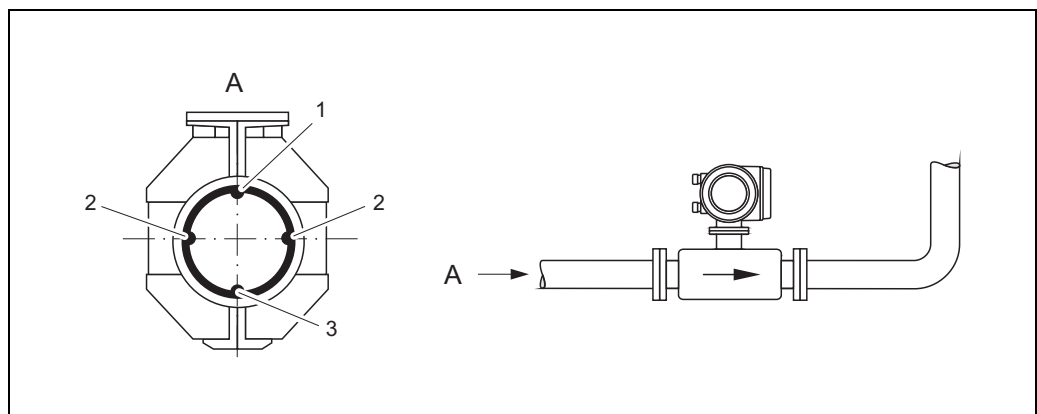

A0011904

Fig. 11: Horizontal orientation

- 1 EPD electrode for empty pipe detection
(not available for "measuring electrode only" option, not in Promag H, DN 2 to 15 (1/12 to 1/2"))
- 2 Measuring electrodes for signal detection
- 3 Reference electrode for potential equalization
(not available for "measuring electrode only" option, not in Promag H)

3.2.4 Inlet and outlet runs

If possible, install the sensor in a location upstream of fittings such as valves, T-pieces, elbows, etc.

Compliance with the following requirements for the inlet and outlet runs is necessary in order to ensure measuring accuracy.

- Inlet run $\geq 5 \times DN$
- Outlet run $\geq 2 \times DN$

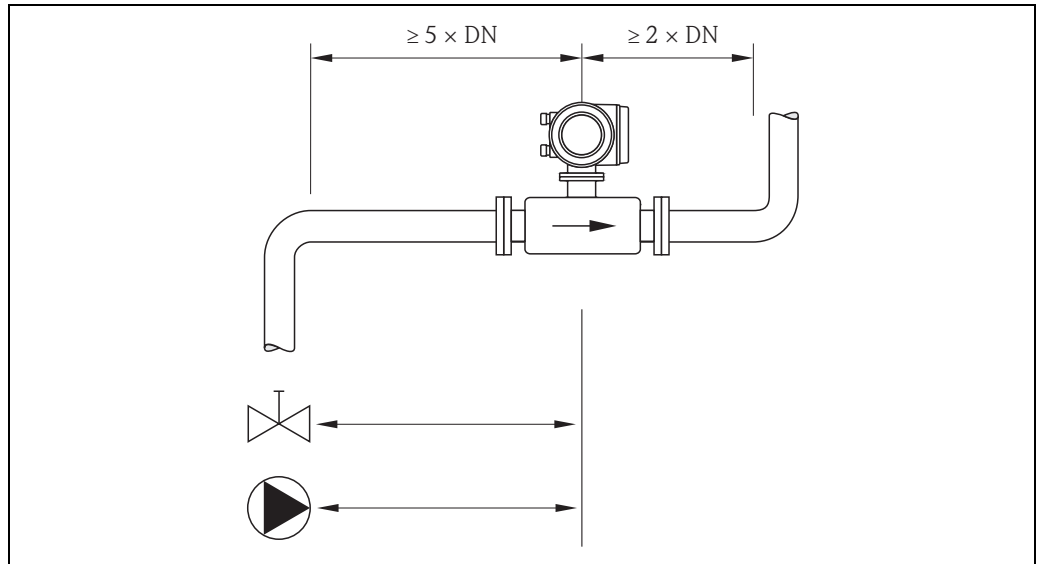

Fig. 12: Inlet and outlet runs

3.2.5 Vibrations

Secure and fix both the piping and the sensor if the vibrations are severe.



Caution!

It is advisable to install sensor and transmitter separately if vibration is excessively severe. Information on the permitted resistance to vibration and shock → 105.

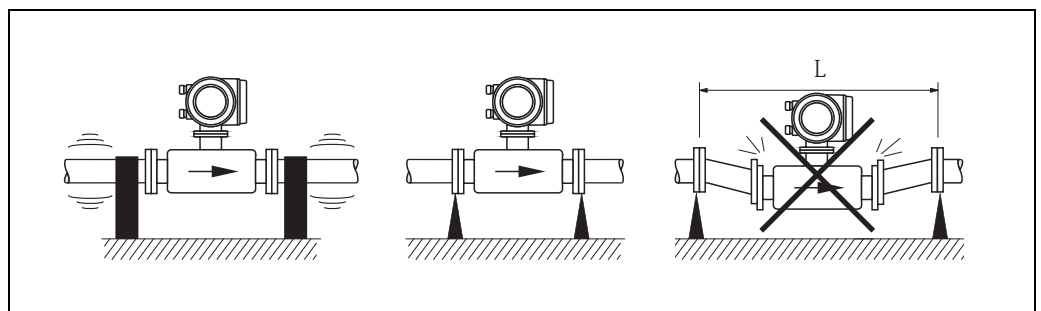

Fig. 13: Measures to prevent vibration of the measuring device ($L > 10\text{ m} / 33\text{ ft}$)

3.2.6 Foundations, supports

If the nominal diameter is $DN \geq 350$ (14"), mount the sensor on a foundation of adequate load-bearing strength.



Caution!

Risk of damage.

Do not support the weight of the sensor on the metal casing: the casing would buckle and damage the internal magnetic coils.

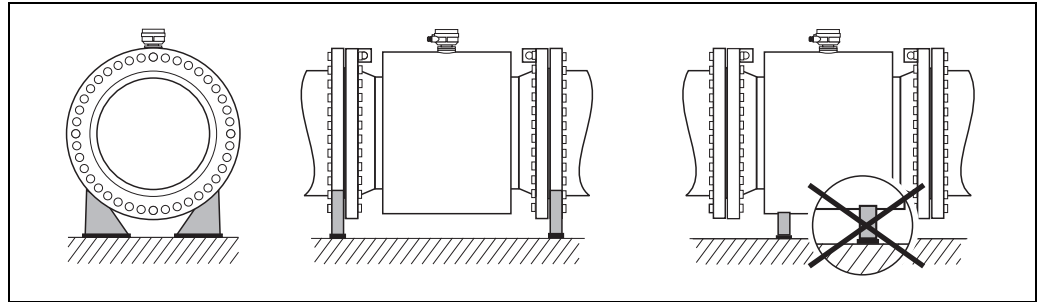

Fig. 14: Correct support for large nominal diameters ($DN \geq 350 / 14''$)

3.2.7 Adapters

Suitable adapters to DIN EN 545 (double-flange reducers) can be used to install the sensor in larger-diameter pipes. The resultant increase in the rate of flow improves measuring accuracy with very slow-moving fluids.

The nomogram shown here can be used to calculate the pressure loss caused by cross-section reduction.



Note!

The nomogram only applies to liquids of viscosity similar to water.

1. Calculate the ratio of the diameters d/D .
2. From the nomogram, read off the pressure loss as a function of fluid velocity (*downstream* from the reduction) and the d/D ratio.

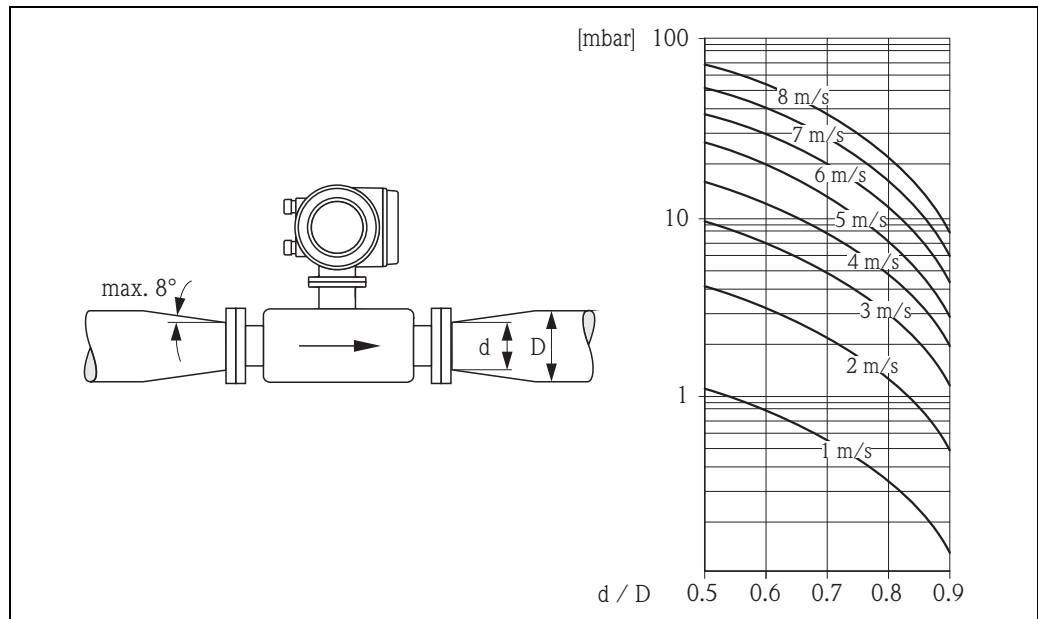

Fig. 15: Pressure loss due to adapters

3.2.8 Nominal diameter and flow rate

The diameter of the pipe and the flow rate determine the nominal diameter of the sensor. The optimum flow velocity is between 2 and 3 m/s (6 to 10 ft/s). The flow velocity (v), moreover, has to be matched to the physical properties of the fluid:

- $v < 2$ m/s (6 ft/s): for abrasive fluids where solids do not cause sedimentation (e.g. lime milk)
- $v > 2$ m/s (6 ft/s): for fluids producing buildup (e.g. wastewater sludge)



Note!

Flow velocity can be increased, if necessary, by reducing the nominal diameter of the sensor through the use of adapters → 16.

Recommended flow (SI units)

Nominal diameter [mm]	Promag E/P	Promag H	Promag W
	Min./max. full scale value ($v \approx 0.3$ or 10 m/s) in [dm ³ /min]		
2	-	0.06 to 1.8	-
4	-	0.25 to 7	-
8	-	1 to 30	-
15	4 to 100	4 to 100	-
25	9 to 300	9 to 300	9 to 300
32	15 to 500	-	15 to 500
40	25 to 700	25 to 700	25 to 700
50	35 to 1100	35 to 1100	35 to 1100
65	60 to 2000	60 to 2000	60 to 2000
80	90 to 3000	90 to 3000	90 to 3000
100	145 to 4700	145 to 4700	145 to 4700
125	220 to 7500	-	220 to 7500
[mm]	Min./max. full scale value ($v \approx 0.3$ or 10 m/s) in [m ³ /h]		
150	20 to 600	-	20 to 600
200	35 to 1100	-	35 to 1100
250	55 to 1700	-	55 to 1700
300	80 to 2400	-	80 to 2400
350	110 to 3300	-	110 to 3300
375	-	-	140 to 4200
400	140 to 4200	-	140 to 4200
450	180 to 5400	-	180 to 5400
500	220 to 6600	-	220 to 6600
600	310 to 9600	-	310 to 9600
700	-	-	420 to 13500
800	-	-	550 to 18000
900	-	-	690 to 22500
1000	-	-	850 to 28000
1200	-	-	1250 to 40000
1400	-	-	1700 to 55000
1600	-	-	2200 to 70000
1800	-	-	2800 to 90000
2000	-	-	3400 to 110000

Recommended flow (US units)

Nominal diameter [inch]	Promag E/P	Promag H	Promag W
	Min./max. full scale value ($v \approx 0.3$ or 10 m/s) in [gal/min]		
1 1/12"	-	0.015 to 0.5	-
5/32"	-	0.07 to 2	-
5/16"	-	0.25 to 8	-
1/2"	1.0 to 27	1.0 to 27	-
1"	2.5 to 80	2.5 to 80	2.5 to 80
1 1/4"	4 to 130	-	4 to 130
1 1/2"	7 to 190	7 to 190	7 to 190
2"	10 to 300	10 to 300	10 to 300
2 1/2"	16 to 500	16 to 500	16 to 500
3"	24 to 800	24 to 800	24 to 800
4"	40 to 1250	40 to 1250	40 to 1250
5"	60 to 1950	-	60 to 1950
6"	90 to 2650	-	90 to 2650
8"	155 to 4850	-	155 to 4850
10"	250 to 7500	-	250 to 7500
12"	350 to 10600	-	350 to 10600
14"	500 to 15000	-	500 to 15000
15"	-	-	600 to 19000
16"	600 to 19000	-	600 to 19000
18"	800 to 24000	-	800 to 24000
20"	1000 to 30000	-	1000 to 30000
24"	1400 to 44000	-	1400 to 44000
28"	-	-	1900 to 60000
30"	-	-	2150 to 67000
32"	-	-	2450 to 80000
36"	-	-	3100 to 100000
40"	-	-	3800 to 125000
42"	-	-	4200 to 135000
48"	-	-	5500 to 175000
[inch]	Min./max. full scale value ($v \approx 0.3$ or 10 m/s) in [Mgal/d]		
54"	-	-	9 to 300
60"	-	-	12 to 380
66"	-	-	14 to 500
72"	-	-	16 to 570
78"	-	-	18 to 650

3.2.9 Length of connecting cable

In order to ensure measuring accuracy, please comply with the following instructions when installing the remote version:

- Secure the cable run or route the cable in an armored conduit. Movement of the cable can falsify the measuring signal, particularly if the fluid conductivity is low.
- Route the cable well clear of electrical machines and switching elements.
- Ensure potential equalization between sensor and transmitter, if necessary.
- The permissible cable length L_{max} depends on the fluid conductivity (\rightarrow 19).

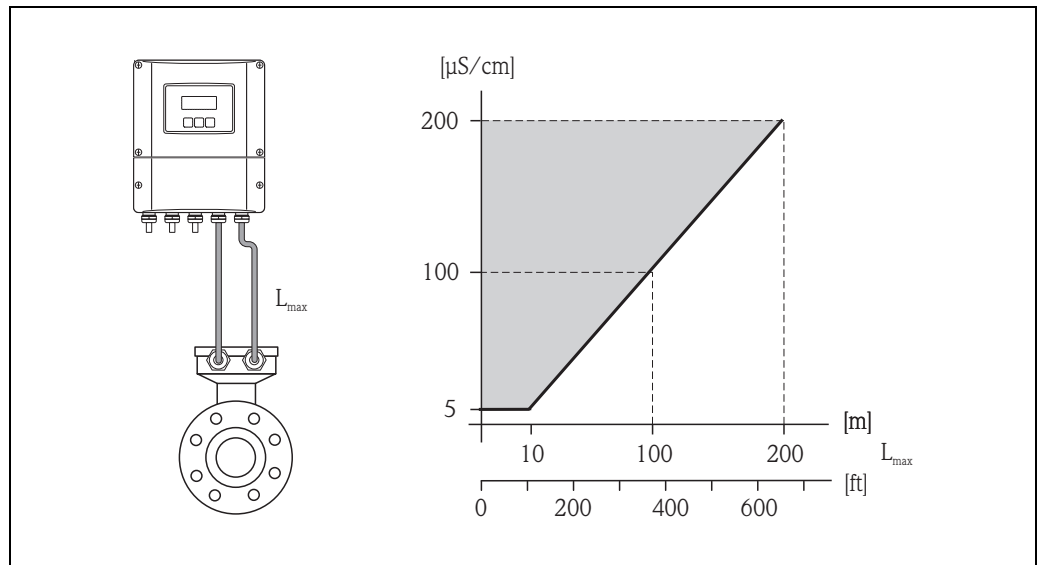

Fig. 16: Permitted lengths for connecting cable in remote version, as a function of the conductivity of the fluid

Gray shaded area = permissible range
 L_{max} = length of connecting cable

3.3 Installation

3.3.1 Installing the Promag E sensor



Caution!

- The protective covers mounted on the two sensor flanges guard the PTFE lining, which is turned over the flanges. Consequently, do not remove these protection plates **until immediately before** the sensor is installed in the pipe.
- Protection plates must remain in place while the device is in storage.
- Make sure that the lining is not damaged or removed from the flanges.



Note!

Bolts, nuts, seals, etc. are not included in the scope of supply and must be supplied by the customer.

The sensor is designed for installation between the two piping flanges:

- It is essential that you observe the necessary screw tightening torques on → 21.
- If grounding disks are used, follow the mounting instructions which will be enclosed with the shipment.

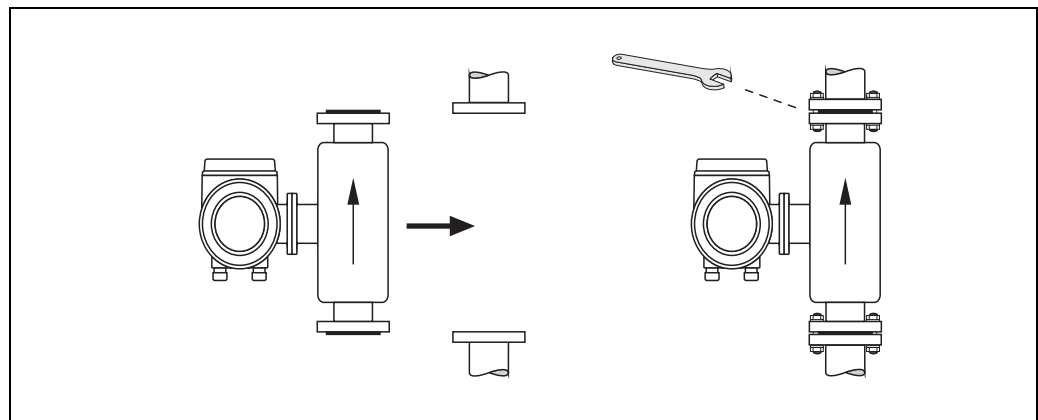

Fig. 17: Installing the Promag P sensor

A0011908

Seals

Comply with the following instructions when installing seals:

- PFA or PTFE lining → seals are **not** required.
- Only use seals that comply with DIN EN 1514-1 for DIN flanges.
- Make sure that the seals do not protrude into the piping cross-section.



Caution!

Risk of short circuit! Do not use electrically conductive sealing compound such as graphite. An electrically conductive layer could form on the inside of the measuring tube and short-circuit the measuring signal.

Ground cable

- If necessary, special ground cables can be ordered as accessories for potential equalization, → 78.
- For information on potential equalization and detailed installation instructions for using ground cables, please refer to → 53.

Screw tightening torques (Promag E)

Note the following points:

- The tightening torques listed below are for lubricated threads only.
- Always tighten the screws uniformly and in diagonally opposite sequence.
- Overtightening the screws will deform the sealing faces or damage the seals.
- The tightening torques listed below apply only to pipes not subjected to tensile stress.

Tightening torques for:

- EN (DIN) → 21
- ASME → 22
- JIS → 22

Promag E tightening torques for EN (DIN)

Nominal diameter [mm]	EN (DIN) Pressure rating [bar]	Threaded fasteners	Max. tightening torque [Nm]
15	PN 40	4 × M 12	11
25	PN 40	4 × M 12	26
32	PN 40	4 × M 16	41
40	PN 40	4 × M 16	52
50	PN 40	4 × M 16	65
65 *	PN 16	8 × M 16	43
80	PN 16	8 × M 16	53
100	PN 16	8 × M 16	57
125	PN 16	8 × M 16	75
150	PN 16	8 × M 20	99
200	PN 10	8 × M 20	141
200	PN 16	12 × M 20	94
250	PN 10	12 × M 20	110
250	PN 16	12 × M 24	131
300	PN 10	12 × M 20	125
300	PN 16	12 × M 24	179
350	PN 6	12 × M 20	200
350	PN 10	16 × M 20	188
350	PN 16	16 × M 24	254
400	PN 6	16 × M 20	166
400	PN 10	16 × M 24	260
400	PN 16	16 × M 27	330
450	PN 6	16 × M 20	202
450	PN 10	20 × M 24	235
450	PN 16	20 × M 27	300
500	PN 6	20 × M 20	176
500	PN 10	20 × M 24	265
500	PN 16	20 × M 30	448
600	PN 6	20 × M 24	242
600	PN 10	20 × M 27	345
600 *	PN 16	20 × M 33	658

* Designed acc. to EN 1092-1 (not to DIN 2501)

Promag E tightening torques for ASME

Nominal diameter		ASME Pressure rating [lbs]	Threaded fasteners	Max. tightening torque PTFE	
[mm]	[inch]			[Nm]	[lbf · ft]
15	½"	Class 150	4 × ½"	6	4
25	1"	Class 150	4 × ½"	11	8
40	1 ½"	Class 150	4 × ½"	24	18
50	2"	Class 150	4 × 5/8"	47	35
80	3"	Class 150	4 × 5/8"	79	58
100	4"	Class 150	8 × 5/8"	56	41
150	6"	Class 150	8 × ¾"	106	78
200	8"	Class 150	8 × ¾"	143	105
250	10"	Class 150	12 × 7/8"	135	100
300	12"	Class 150	12 × 7/8"	178	131
350	14"	Class 150	12 × 1"	260	192
400	16"	Class 150	16 × 1"	246	181
450	18"	Class 150	16 × 1 1/8"	371	274
500	20"	Class 150	20 × 1 1/8"	341	252
600	24"	Class 150	20 × 1 ¼"	477	352

Promag E tightening torques for JIS

Nominal diameter [mm]	JIS Pressure rating	Threaded fasteners	Max. tightening torque [Nm] PTFE
15	20K	4 × M 12	16
25	20K	4 × M 16	32
32	20K	4 × M 16	38
40	20K	4 × M 16	41
50	10K	4 × M 16	54
65	10K	4 × M 16	74
80	10K	8 × M 16	38
100	10K	8 × M 16	47
125	10K	8 × M 20	80
150	10K	8 × M 20	99
200	10K	12 × M 20	82
250	10K	12 × M 22	133
300	10K	16 × M 22	99

3.3.2 Installing the Promag H sensor

The sensor is supplied, as per your order, with or without installed process connections. Installed process connections are screwed onto the sensor using 4 or 6 hexagonal-headed bolts.



Caution!

Depending on the application and the length of the pipe, the sensor must be supported or more securely mounted if necessary. Particularly when using process connections made of plastic, it is essential that the sensor be mounted securely. A wall mounting kit for this purpose can be ordered separately as an accessory from Endress+Hauser (→ 78).

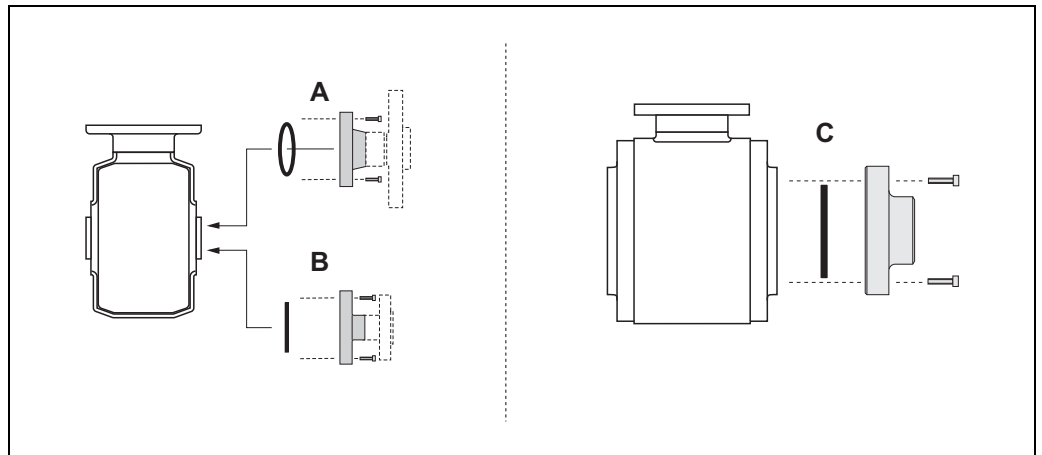

Fig. 18: Promag H process connections; DN 2 to 25 (1/12 to 1"), DN 40 to 100 (1 1/2 to 4")

A = DN 2 to 25 (1/12 to 1") / Process connections with O-ring

Weld nipple (DIN EN ISO 1127, ODT / SMS), flange (EN (DIN), ASME, JIS), flange made of PVDF (EN (DIN), ASME, JIS), external thread, internal thread, hose connection, PVC adhesive fitting

B = DN 2 to 25 (1/12 to 1") / Process connections with aseptic molded seal

Weld nipple (DIN 11850, ODT / SMS), clamp (ISO 2852, DIN 32676, L14 AM7), coupling (DIN 11851, DIN 11864-1, SMS 1145), flange DIN 11864-2

C = DN 40 to 100 (1 1/2 to 4") / Process connections with aseptic molded seal

Weld nipple (DIN 11850, ODT / SMS), clamp (ISO 2852, DIN 32676, L14 AM7), coupling (DIN 11851, DIN 11864-1, ISO 2853, SMS 1145), flange DIN 11864-2

Seals

When mounting the process connections, please ensure that the relevant seals are clean and properly centered.



Caution!

- In the case of metallic process connections, the screws must be fully tightened. The process connection forms a metallic connection with the sensor, which ensures a defined compression of the seal.
- In the case of process connections made of plastic, the maximum screw tightening torques for lubricated threads (7 Nm / 5.2 lbf ft) must be adhered to. In the case of plastic flanges, a seal must always be used between the connection and the counterflange.
- Depending on the application, the seals should be replaced periodically, particularly when molded seals (aseptic version) are used!

The interval between replacements depends on the frequency of the cleaning cycles and on the temperatures of the fluid and the cleaning process. Replacement seals can be ordered as an accessory at a later stage → 78.

Using and installing grounding rings (DN 2 to 25 / 1/12 to 1")

In case the process connections are made of plastic (e.g. flanges or adhesive fittings), the potential between the sensor and the fluid must be equalised using additional ground rings. If the ground rings are not installed this can affect the accuracy of the measurements or cause the destruction of the sensor through the galvanic corrosion of the electrodes.



Caution!

- Depending on the option ordered, plastic rings may be installed at the process connections instead of ground rings. These plastic rings serve only as spacers and have no potential equalization function. In addition, they provide a sealing function at the interface between the sensor and process connection. For this reason, with process connections without ground rings, these plastic rings/seals must not be removed, or must always be installed.
- Ground rings can be ordered separately from Endress+Hauser as accessories → 78. When placing the order, make certain that the ground ring is compatible with the material used for the electrodes. Otherwise, there is a risk that the electrodes may be destroyed by galvanic corrosion! Information about the materials can be found on → 117.
- Ground rings, including the seals, are mounted within the process connections. Therefore, the fitting length is not affected.

1. Loosen the four or six hexagonal headed bolts (1) and remove the process connection from the sensor (4).
2. Remove the plastic ring (3), including the two O-ring seals (2).
3. Place one seal (2) in the groove of the process connection.
4. Place the metal ground ring (3) on the process connection.
5. Now place the second seal (2) in the groove of the ground ring.
6. Finally, mount the process connection on the sensor again. With plastic process connections, note the max. torques for lubricated threads (7 Nm / 5.2 lbf ft).

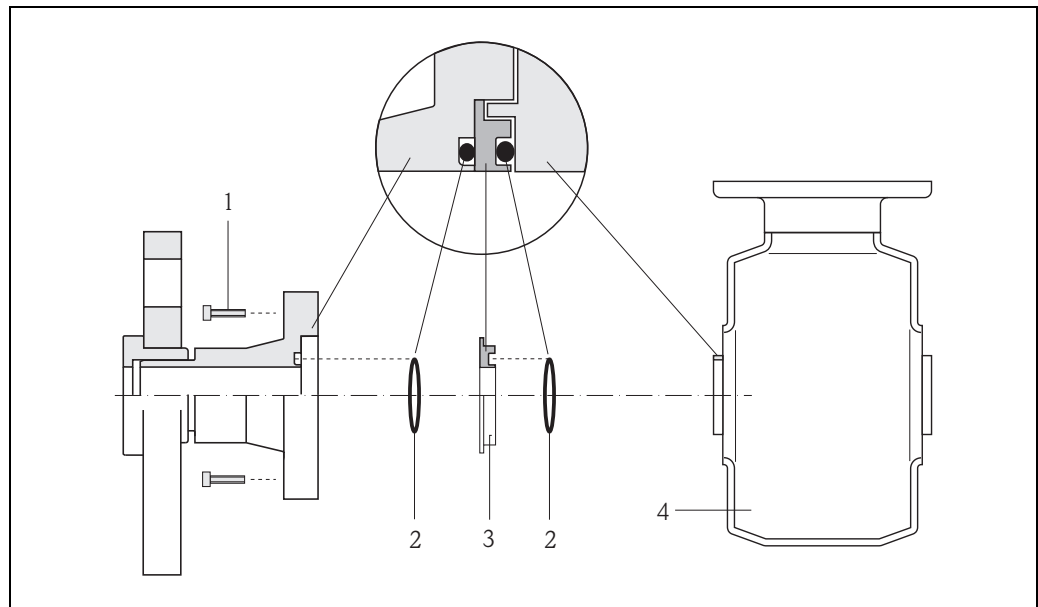

Fig. 19: Installing grounding rings in the Promag H (DN 2 to 25 / 1/12 to 1")

- 1 = Hexagonal-headed bolts, process connection
 2 = O-ring seals
 3 = Grounding ring or plastic ring (spacer)
 4 = Sensor

Welding the transmitter into the pipe (weld nipple)



Caution!

Risk of electronics being destroyed. Please ensure that the welding system is *not* grounded via the sensor or transmitter.

1. Secure the sensor using several welding points in the piping. A welding jig suitable for this purpose can be ordered separately as an accessory → 78.
2. Loosen the screws at the process connection flange, and remove the sensor incl. seal from the piping.
3. Weld the process connection into the pipe.
4. Mount the sensor back into the pipe. When doing so, make sure that the seal is clean and positioned correctly.



Note!

- If the welding is done properly with thin-walled food pipes, the seal will not be damaged by heat even when mounted. Nonetheless, it is recommended that you dismantle the sensor and seal.
- For dismantling purposes, it must be possible to open the piping a total of approx. 8 mm.

Cleaning using pigs

When cleaning using pigs, please note the internal diameters of the measuring tube and the process connection. All the dimensions and lengths of the sensor and transmitter are provided in the separate documentation "Technical Information" → 123.

3.3.3 Installing the Promag P sensor



Caution!

- The protective covers mounted on the two sensor flanges guard the PTFE lining, which is turned over the flanges. Consequently, do not remove these protection plates **until immediately before** the sensor is installed in the pipe.
- Protection plates must remain in place while the device is in storage.
- Make sure that the lining is not damaged or removed from the flanges.



Note!

Bolts, nuts, seals, etc. are not included in the scope of supply and must be supplied by the customer.

The sensor is designed for installation between the two piping flanges:

- It is essential that you observe the necessary screw tightening torques on → 27.
- If grounding disks are used, follow the mounting instructions which will be enclosed with the shipment.

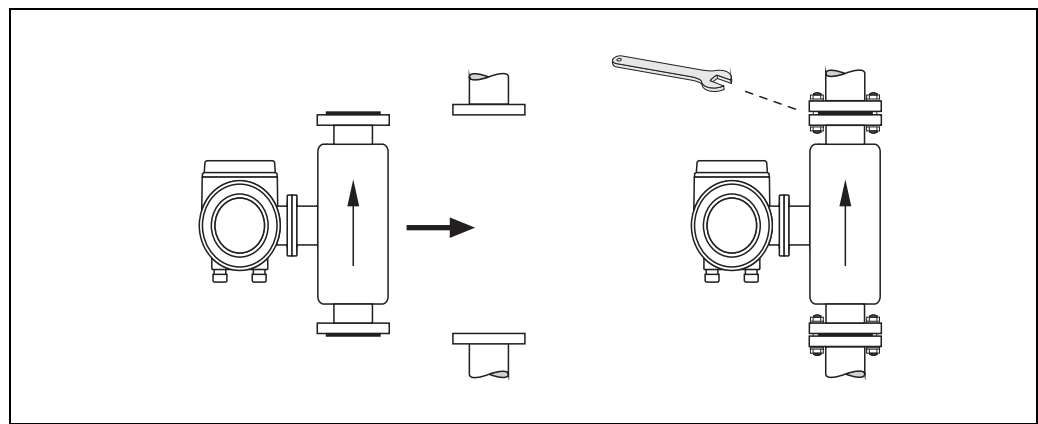

A0011908

Fig. 20: Installing the Promag P sensor

Seals

Comply with the following instructions when installing seals:

- PFA or PTFE lining → seals are **not** required.
- Only use seals that comply with DIN EN 1514-1 for DIN flanges.
- Make sure that the seals do not protrude into the piping cross-section.



Caution!

Risk of short circuit! Do not use electrically conductive sealing compound such as graphite. An electrically conductive layer could form on the inside of the measuring tube and short-circuit the measuring signal.

Ground cable

- If necessary, special ground cables can be ordered as accessories for potential equalization, → 78.
- For information on potential equalization and detailed installation instructions for using ground cables, please refer to → 53.

Installing the high-temperature version (with PFA lining)

The high-temperature version has a housing support for the thermal separation of sensor and transmitter. The high-temperature version is always used for applications in which high ambient temperatures are encountered in conjunction with high fluid temperatures. The high-temperature version is obligatory if the fluid temperature exceeds $+150\text{ °C}$ ($+300\text{ °F}$).



Note!

You will find information on permissible temperature ranges on → 106.

Insulation

Pipes generally have to be insulated if they carry very hot fluids to avoid energy losses and prevent accidental contact with pipes at temperatures that could cause injury. Guidelines regulating the insulation of pipes have to be taken into account.



Caution!

Risk of electronics overheating. The housing support dissipates heat and its entire surface area must remain uncovered. Make sure that the sensor insulation does not extend past the top of the two sensor half-shells.

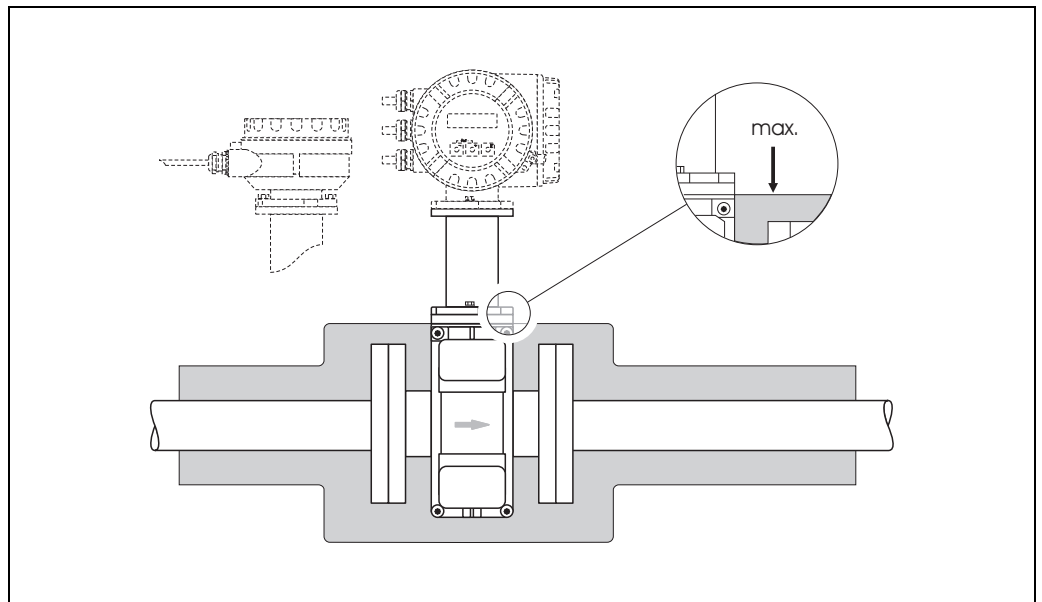

Fig. 21: Promag P sensor (high-temperature version): insulating the pipe

Screw tightening torques (Promag P)

Note the following points:

- The tightening torques listed below are for lubricated threads only.
- Always tighten the screws uniformly and in diagonally opposite sequence.
- Overtightening the screws will deform the sealing faces or damage the seals.
- The tightening torques listed below apply only to pipes not subjected to tensile stress.

Tightening torques for:

- EN (DIN) → 28
- ASME → 29
- JIS → 29
- AS 2129 → 30
- AS 4087 → 30

Promag P tightening torques for EN (DIN)

Nominal diameter [mm]	EN (DIN) Pressure rating [bar]	Screws	Max. tightening torque [Nm]	
			PTFE	PFA
15	PN 40	4 × M 12	11	-
25	PN 40	4 × M 12	26	20
32	PN 40	4 × M 16	41	35
40	PN 40	4 × M 16	52	47
50	PN 40	4 × M 16	65	59
65 *	PN 16	8 × M 16	43	40
65	PN 40	8 × M 16	43	40
80	PN 16	8 × M 16	53	48
80	PN 40	8 × M 16	53	48
100	PN 16	8 × M 16	57	51
100	PN 40	8 × M 20	78	70
125	PN 16	8 × M 16	75	67
125	PN 40	8 × M 24	111	99
150	PN 16	8 × M 20	99	85
150	PN 40	8 × M 24	136	120
200	PN 10	8 × M 20	141	101
200	PN 16	12 × M 20	94	67
200	PN 25	12 × M 24	138	105
250	PN 10	12 × M 20	110	-
250	PN 16	12 × M 24	131	-
250	PN 25	12 × M 27	200	-
300	PN 10	12 × M 20	125	-
300	PN 16	12 × M 24	179	-
300	PN 25	16 × M 27	204	-
350	PN 10	16 × M 20	188	-
350	PN 16	16 × M 24	254	-
350	PN 25	16 × M 30	380	-
400	PN 10	16 × M 24	260	-
400	PN 16	16 × M 27	330	-
400	PN 25	16 × M 33	488	-
450	PN 10	20 × M 24	235	-
450	PN 16	20 × M 27	300	-
450	PN 25	20 × M 33	385	-
500	PN 10	20 × M 24	265	-
500	PN 16	20 × M 30	448	-
500	PN 25	20 × M 33	533	-
600	PN 10	20 × M 27	345	-
600 *	PN 16	20 × M 33	658	-
600	PN 25	20 × M 36	731	-
* Designed acc. to EN 1092-1 (not to DIN 2501)				

Promag P tightening torques for ASME

Nominal diameter		ASME Pressure rating [lbs]	Screws	Max. tightening torque			
[mm]	[inch]			PTFE		PFA	
				[Nm]	[lbf · ft]	[Nm]	[lbf · ft]
15	½"	Class 150	4 × ½"	6	4	–	–
15	½"	Class 300	4 × ½"	6	4	–	–
25	1"	Class 150	4 × ½"	11	8	10	7
25	1"	Class 300	4 × 5/8"	14	10	12	9
40	1 ½"	Class 150	4 × ½"	24	18	21	15
40	1 ½"	Class 300	4 × ¾"	34	25	31	23
50	2"	Class 150	4 × 5/8"	47	35	44	32
50	2"	Class 300	8 × 5/8"	23	17	22	16
80	3"	Class 150	4 × 5/8"	79	58	67	49
80	3"	Class 300	8 × ¾"	47	35	42	31
100	4"	Class 150	8 × 5/8"	56	41	50	37
100	4"	Class 300	8 × ¾"	67	49	59	44
150	6"	Class 150	8 × ¾"	106	78	86	63
150	6"	Class 300	12 × ¾"	73	54	67	49
200	8"	Class 150	8 × ¾"	143	105	109	80
250	10"	Class 150	12 × 7/8"	135	100	–	–
300	12"	Class 150	12 × 7/8"	178	131	–	–
350	14"	Class 150	12 × 1"	260	192	–	–
400	16"	Class 150	16 × 1"	246	181	–	–
450	18"	Class 150	16 × 1 1/8"	371	274	–	–
500	20"	Class 150	20 × 1 1/8"	341	252	–	–
600	24"	Class 150	20 × 1 ¼"	477	352	–	–

Promag P tightening torques for JIS

Nominal diameter		JIS Pressure rating	Screws	Max. tightening torque [Nm]	
[mm]				PTFE	PFA
15		10K	4 × M 12	16	–
15		20K	4 × M 12	16	–
25		10K	4 × M 16	32	27
25		20K	4 × M 16	32	27
32		10K	4 × M 16	38	–
32		20K	4 × M 16	38	–
40		10K	4 × M 16	41	37
40		20K	4 × M 16	41	37
50		10K	4 × M 16	54	46
50		20K	8 × M 16	27	23
65		10K	4 × M 16	74	63
65		20K	8 × M 16	37	31
80		10K	8 × M 16	38	32
80		20K	8 × M 20	57	46
100		10K	8 × M 16	47	38
100		20K	8 × M 20	75	58
125		10K	8 × M 20	80	66
125		20K	8 × M 22	121	103

Nominal diameter [mm]	JIS Pressure rating	Screws	Max. tightening torque [Nm]	
			PTFE	PFA
150	10K	8 × M 20	99	81
150	20K	12 × M 22	108	72
200	10K	12 × M 20	82	54
200	20K	12 × M 22	121	88
250	10K	12 × M 22	133	-
250	20K	12 × M 24	212	-
300	10K	16 × M 22	99	-
300	20K	16 × M 24	183	-

Promag P tightening torques for AS 2129

Nominal diameter [mm]	AS 2129 Pressure rating	Screws	Max. tightening torque [Nm] PTFE
25	Table E	4 × M 12	21
50	Table E	4 × M 16	42

Promag P tightening torques for AS 4087

Nominal diameter [mm]	AS 4087 Pressure rating	Screws	Max. tightening torque [Nm] PTFE
50	PN 16	4 × M 16	42

3.3.4 Installing the Promag W sensor



Note!

Bolts, nuts, seals, etc. are not included in the scope of supply and must be supplied by the customer.

The sensor is designed for installation between the two piping flanges:

- It is essential that you observe the necessary screw tightening torques on → 31.
- If grounding disks are used, follow the mounting instructions which will be enclosed with the shipment.

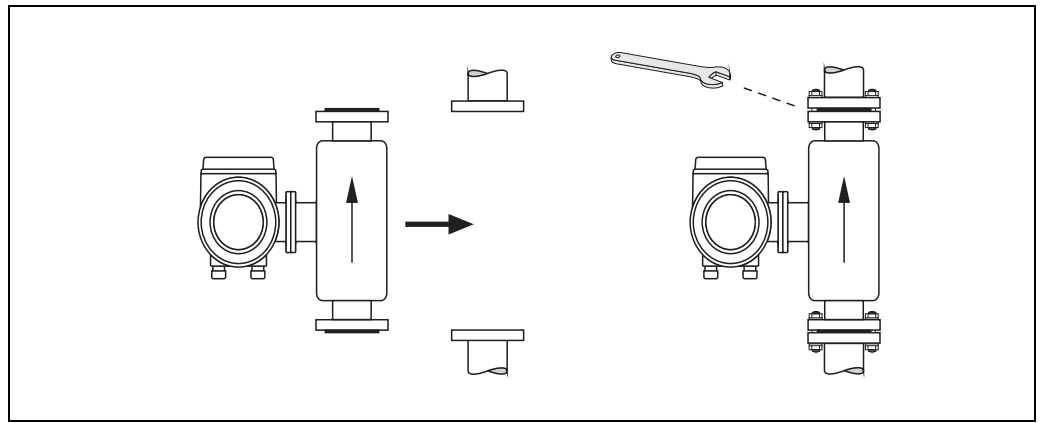

Fig. 22: Installing the Promag W sensor

Seals

Comply with the following instructions when installing seals:

- Hard rubber lining → additional seals are **always** required.
- Polyurethane lining → seals are **not** required.
- Only use seals that comply with DIN EN 1514-1 for DIN flanges.
- Make sure that the seals do not protrude into the piping cross-section.



Caution!

Risk of short circuit! Do not use electrically conductive sealing compound such as graphite. An electrically conductive layer could form on the inside of the measuring tube and short-circuit the measuring signal.

Ground cable

- If necessary, special ground cables can be ordered as accessories for potential equalization, → 78.
- For information on potential equalization and detailed installation instructions for using ground cables, please refer to → 53.

Screw tightening torques (Promag W)

Note the following points:

- The tightening torques listed below are for lubricated threads only.
- Always tighten the screws uniformly and in diagonally opposite sequence.
- Overtightening the screws will deform the sealing faces or damage the seals.
- The tightening torques listed below apply only to pipes not subjected to tensile stress.

Tightening torques for:

- EN (DIN) → 32
- JIS → 33
- ASME → 34
- AWWA → 34
- AS 2129 → 35
- AS 4087 → 35

Promag W tightening torques for EN (DIN)

Nominal diameter [mm]	EN (DIN) Pressure rating [bar]	Screws	Max. tightening torque [Nm]	
			Hard rubber	Polyurethane
25	PN 40	4 × M 12	-	15
32	PN 40	4 × M 16	-	24
40	PN 40	4 × M 16	-	31
50	PN 40	4 × M 16	-	40
65*	PN 16	8 × M 16	32	27
65	PN 40	8 × M 16	32	27
80	PN 16	8 × M 16	40	34
80	PN 40	8 × M 16	40	34
100	PN 16	8 × M 16	43	36
100	PN 40	8 × M 20	59	50
125	PN 16	8 × M 16	56	48
125	PN 40	8 × M 24	83	71
150	PN 16	8 × M 20	74	63
150	PN 40	8 × M 24	104	88
200	PN 10	8 × M 20	106	91
200	PN 16	12 × M 20	70	61
200	PN 25	12 × M 24	104	92
250	PN 10	12 × M 20	82	71
250	PN 16	12 × M 24	98	85
250	PN 25	12 × M 27	150	134
300	PN 10	12 × M 20	94	81
300	PN 16	12 × M 24	134	118
300	PN 25	16 × M 27	153	138
350	PN 6	12 × M 20	111	120
350	PN 10	16 × M 20	112	118
350	PN 16	16 × M 24	152	165
350	PN 25	16 × M 30	227	252
400	PN 6	16 × M 20	90	98
400	PN 10	16 × M 24	151	167
400	PN 16	16 × M 27	193	215
400	PN 25	16 × M 33	289	326
450	PN 6	16 × M 20	112	126
450	PN 10	20 × M 24	153	133
450	PN 16	20 × M 27	198	196
450	PN 25	20 × M 33	256	253
500	PN 6	20 × M 20	119	123
500	PN 10	20 × M 24	155	171
500	PN 16	20 × M 30	275	300
500	PN 25	20 × M 33	317	360
600	PN 6	20 × M 24	139	147
600	PN 10	20 × M 27	206	219
600 *	PN 16	20 × M 33	415	443
600	PN 25	20 × M 36	431	516
700	PN 6	24 × M 24	148	139
700	PN 10	24 × M 27	246	246

Nominal diameter [mm]	EN (DIN) Pressure rating [bar]	Screws	Max. tightening torque [Nm]	
			Hard rubber	Polyurethane
700	PN 16	24 × M 33	278	318
700	PN 25	24 × M 39	449	507
800	PN 6	24 × M 27	206	182
800	PN 10	24 × M 30	331	316
800	PN 16	24 × M 36	369	385
800	PN 25	24 × M 45	664	721
900	PN 6	24 × M 27	230	637
900	PN 10	28 × M 30	316	307
900	PN 16	28 × M 36	353	398
900	PN 25	28 × M 45	690	716
1000	PN 6	28 × M 27	218	208
1000	PN 10	28 × M 33	402	405
1000	PN 16	28 × M 39	502	518
1000	PN 25	28 × M 52	970	971
1200	PN 6	32 × M 30	319	299
1200	PN 10	32 × M 36	564	568
1200	PN 16	32 × M 45	701	753
1400	PN 6	36 × M 33	430	398
1400	PN 10	36 × M 39	654	618
1400	PN 16	36 × M 45	729	762
1600	PN 6	40 × M 33	440	417
1600	PN 10	40 × M 45	946	893
1600	PN 16	40 × M 52	1007	1100
1800	PN 6	44 × M 36	547	521
1800	PN 10	44 × M 45	961	895
1800	PN 16	44 × M 52	1108	1003
2000	PN 6	48 × M 39	629	605
2000	PN 10	48 × M 45	1047	1092
2000	PN 16	48 × M 56	1324	1261

* Designed acc. to EN 1092-1 (not to DIN 2501)

Promag W tightening torques for JIS

Sensor Nominal diameter [mm]	JIS Pressure rating	Screws	Max. tightening torque [Nm]	
			Hard rubber	Polyurethane
25	10K	4 × M 16	-	19
25	20K	4 × M 16	-	19
32	10K	4 × M 16	-	22
32	20K	4 × M 16	-	22
40	10K	4 × M 16	-	24
40	20K	4 × M 16	-	24
50	10K	4 × M 16	-	33
50	20K	8 × M 16	-	17
65	10K	4 × M 16	55	45
65	20K	8 × M 16	28	23
80	10K	8 × M 16	29	23
80	20K	8 × M 20	42	35
100	10K	8 × M 16	35	29
100	20K	8 × M 20	56	48
125	10K	8 × M 20	60	51
125	20K	8 × M 22	91	79
150	10K	8 × M 20	75	63

Sensor Nominal diameter [mm]	JIS Pressure rating	Screws	Max. tightening torque [Nm]	
			Hard rubber	Polyurethane
150	20K	12 × M 22	81	72
200	10K	12 × M 20	61	52
200	20K	12 × M 22	91	80
250	10K	12 × M 22	100	87
250	20K	12 × M 24	159	144
300	10K	16 × M 22	74	63
300	20K	16 × M 24	138	124

Promag W tightening torques for ASME

Sensor Nominal diameter [inch]	ASME Pressure rating [lbs]	Screws	Max. tightening torque [Nm]	
			Hard rubber	Polyurethane
1"	Class 150	4 × ½"	–	7
1"	Class 300	4 × 5/8"	–	8
1 ½"	Class 150	4 × ½"	–	10
1 ½"	Class 300	4 × ¾"	–	15
2"	Class 150	4 × 5/8"	–	22
2"	Class 300	8 × 5/8"	–	11
3"	Class 150	4 × 5/8"	60	43
3"	Class 300	8 × ¾"	38	26
4"	Class 150	8 × 5/8"	42	31
4"	Class 300	8 × ¾"	58	40
6"	Class 150	8 × ¾"	79	59
6"	Class 300	12 × ¾"	70	51
8"	Class 150	8 × ¾"	107	80
10"	Class 150	12 × 7/8"	101	75
12"	Class 150	12 × 7/8"	133	103
14"	Class 150	12 × 1"	135	158
16"	Class 150	16 × 1"	128	150
18"	Class 150	16 × 1 1/8"	204	234
20"	Class 150	20 × 1 1/8"	183	217
24"	Class 150	20 × 1 ¼"	268	307

Promag W tightening torques for AWWA

Sensor Nominal diameter [inch]	AWWA Pressure rating	Screws	Max. tightening torque [Nm]	
			Hard rubber	Polyurethane
28"	Class D	28 × 1 ¼"	247	292
30"	Class D	28 × 1 ¼"	287	302
32"	Class D	28 × 1 ½"	394	422
36"	Class D	32 × 1 ½"	419	430
40"	Class D	36 × 1 ½"	420	477
42"	Class D	36 × 1 ½"	528	518
48"	Class D	44 × 1 ½"	552	531
54"	Class D	44 × 1 ¾"	730	633

Sensor Nominal diameter [inch]	AWWA Pressure rating	Screws	Max. tightening torque [Nm]	
			Hard rubber	Polyurethane
60"	Class D	52 × 1 ¾"	758	832
66"	Class D	52 × 1 ¾"	946	955
72"	Class D	60 × 1 ¾"	975	1087
78"	Class D	64 × 2"	853	786

Promag W tightening torques for AS 2129

Sensor Nominal diameter [mm]	AS 2129 Pressure rating	Screws	Max. tightening torque [Nm]
			Hard rubber
80	Table E	4 × M 16	49
100	Table E	8 × M 16	38
150	Table E	8 × M 20	64
200	Table E	8 × M 20	96
250	Table E	12 × M 20	98
300	Table E	12 × M 24	123
350	Table E	12 × M 24	203
400	Table E	12 × M 24	226
500	Table E	16 × M 24	271
600	Table E	16 × M 30	439
700	Table E	20 × M 30	355
750	Table E	20 × M 30	559
800	Table E	20 × M 30	631
900	Table E	24 × M 30	627
1000	Table E	24 × M 30	634
1200	Table E	32 × M 30	727

Promag W tightening torques for AS 4087

Sensor Nominal diameter [mm]	AS 4087 Pressure rating	Screws	Max. tightening torque [Nm]
			Hard rubber
80	PN 16	4 × M 16	49
100 *	PN 16	8 × M 16	38
150	PN 16	8 × M 20	52
200	PN 16	8 × M 20	77
250	PN 16	8 × M 20	147
300	PN 16	12 × M 24	103
350	PN 16	12 × M 24	203
375	PN 16	12 × M 24	137
400	PN 16	12 × M 24	226
500	PN 16	16 × M 24	271
600	PN 16	16 × M 30	393
700	PN 16	20 × M 27	330
750	PN 16	20 × M 30	529
800	PN 16	20 × M 33	631
900	PN 16	24 × M 33	627
1000	PN 16	24 × M 33	595
1200	PN 16	32 × M 33	703

* Designed acc. to AS 2129 (not to AS 4087)

3.3.5 Turning the transmitter housing

Turning the aluminum field housing



Warning!

The rotating mechanism in devices with Ex d/de or FM/CSA Cl. I Div. 1 approval is different to that described here. The relevant procedure is described in the Ex-specific documentation.

1. Loosen the two securing screws.
2. Turn the bayonet catch as far as it will go.
3. Carefully lift the transmitter housing as far as it will go.
4. Turn the transmitter housing to the desired position (max. $2 \times 90^\circ$ in either direction).
5. Lower the housing into position and reengage the bayonet catch.
6. Retighten the two securing screws.

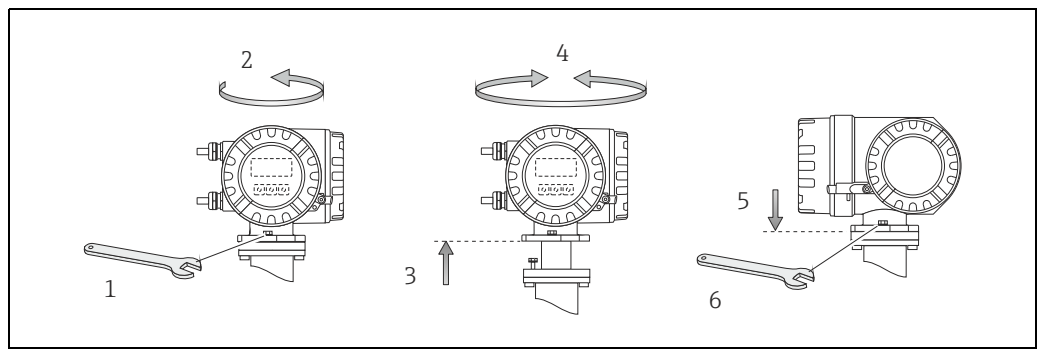

Fig. 23: Turning the transmitter housing (aluminum field housing)

Turning the stainless steel field housing

1. Loosen the two securing screws.
2. Carefully lift the transmitter housing as far as it will go.
3. Turn the transmitter housing to the desired position (max. $2 \times 90^\circ$ in either direction).
4. Lower the housing into position once more.
5. Retighten the two securing screws.

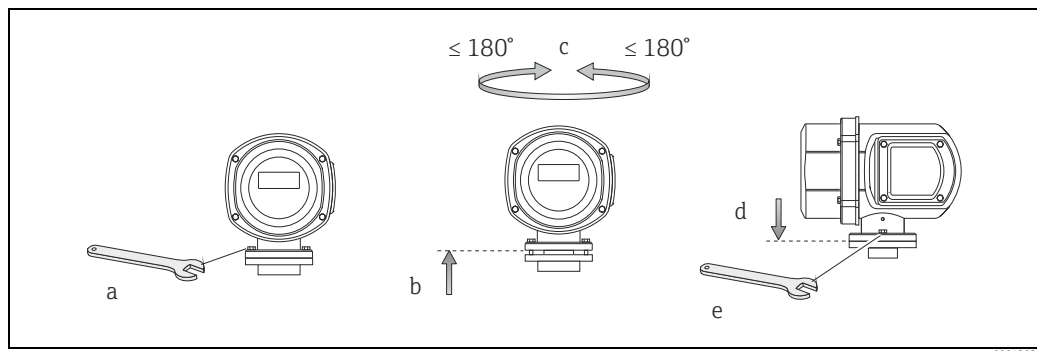

Fig. 24: Turning the transmitter housing (stainless steel field housing)

3.3.6 Turning the local display

1. Unscrew the electronics compartment cover from the transmitter housing.
2. Press the latches on the side of the display module and pull the module out of the electronics compartment cover.
3. Turn the display to the desired position (max. $4 \times 45^\circ$ in both directions) and position it back on the electronics compartment cover.
4. Screw the cover of the electronics compartment firmly onto the transmitter housing.

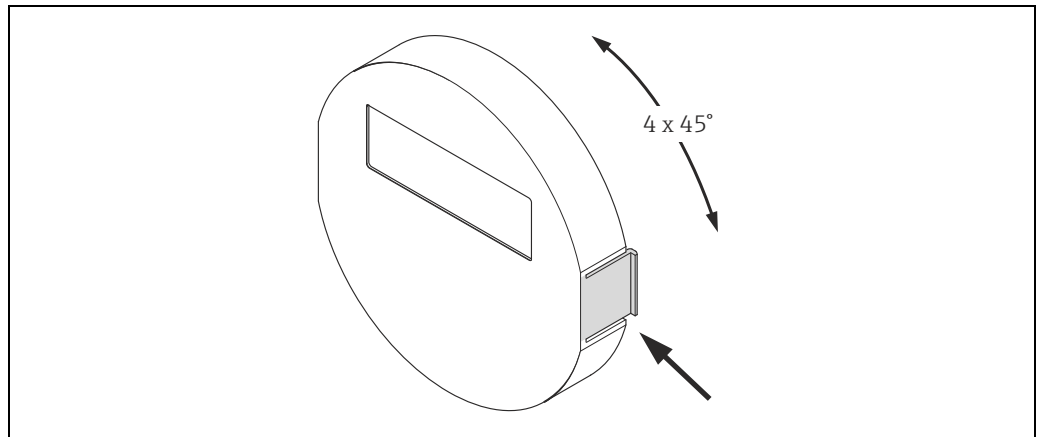



Fig. 25: Turning the local display (field housing)

a0003236

3.3.7 Installing the wall-mount housing

There are various ways of installing the wall-mount housing:

- Mounted directly on the wall
- Panel mounting (with separate mounting kit, accessories) →  39
- Pipe mounting (with separate mounting kit, accessories) →  39



Caution!

- Make sure that the permitted ambient temperature range is observed (see nameplate or →  104). Install the device in a shady location. Avoid direct sunlight.
- Always install the wall-mount housing in such a way that the cable entries are pointing down.

Mounted directly on the wall

1. Drill the holes as illustrated.
2. Remove the cover of the connection compartment (a).
3. Push the two securing screws (b) through the appropriate bores (c) in the housing.
 - Securing screws (M6): max. \varnothing 6.5 mm (0.24")
 - Screw head: max. \varnothing 10.5 mm (0.4")
4. Secure the transmitter housing to the wall as indicated.
5. Screw the cover of the connection compartment (a) firmly onto the housing.

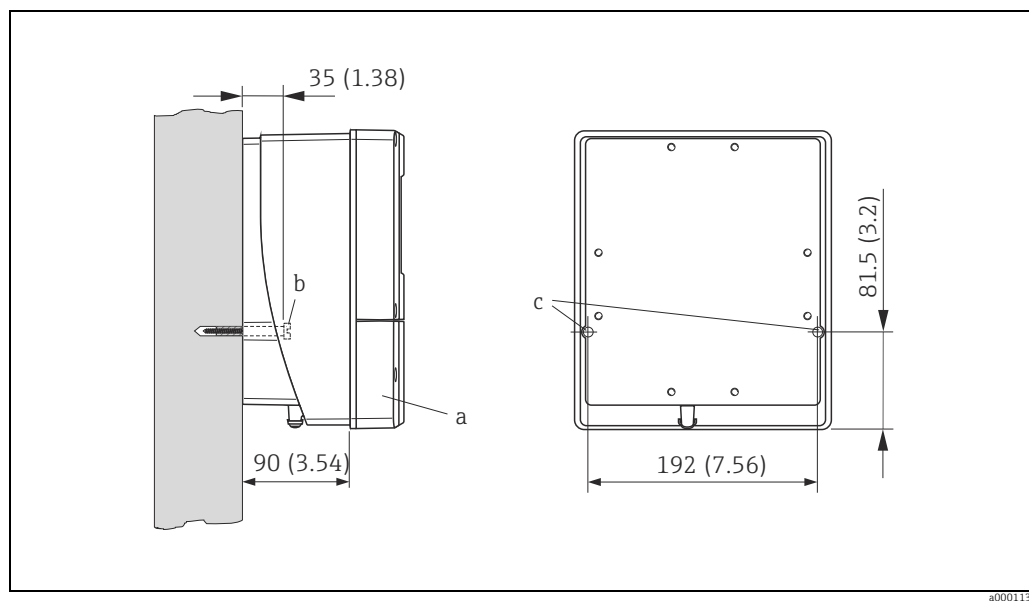

Fig. 26: Mounted directly on the wall

a0001130

Panel mounting

1. Prepare the opening in the panel as illustrated.
2. Slide the housing into the opening in the panel from the front.
3. Screw the fasteners onto the wall-mount housing.
4. Place the threaded rods in the fasteners and screw them down until the housing is seated tightly against the panel wall. Afterwards, tighten the locking nuts.
Additional support is not necessary.

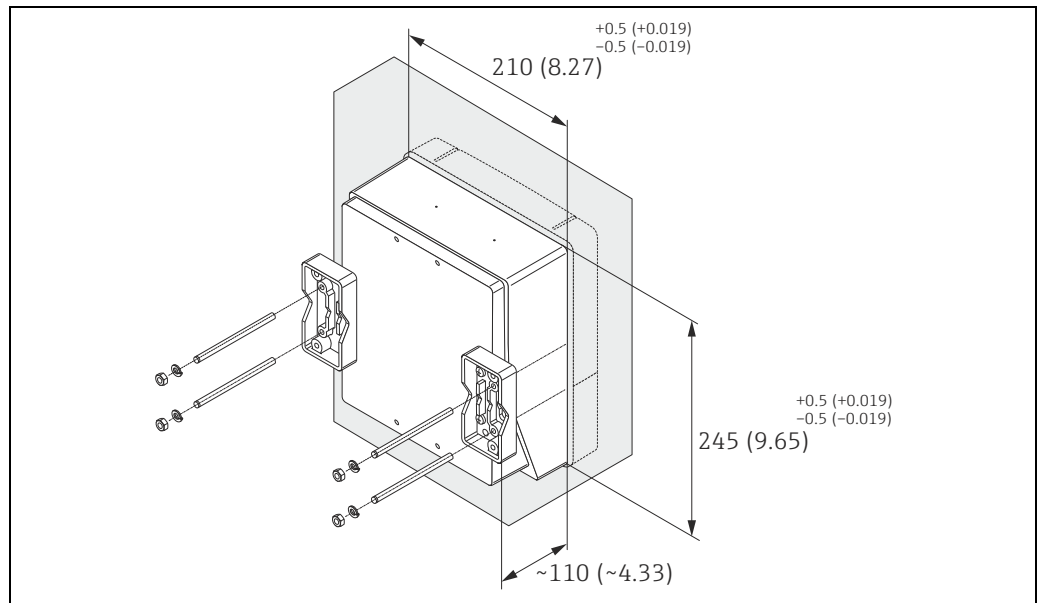

Fig. 27: Panel mounting (wall-mount housing)

Pipe mounting

The assembly should be performed by following the instructions in the following diagram.



Caution!

If the device is mounted to a warm pipe, make sure that the housing temperature does not exceed +60 °C (+140 °F), which is the maximum permissible temperature.

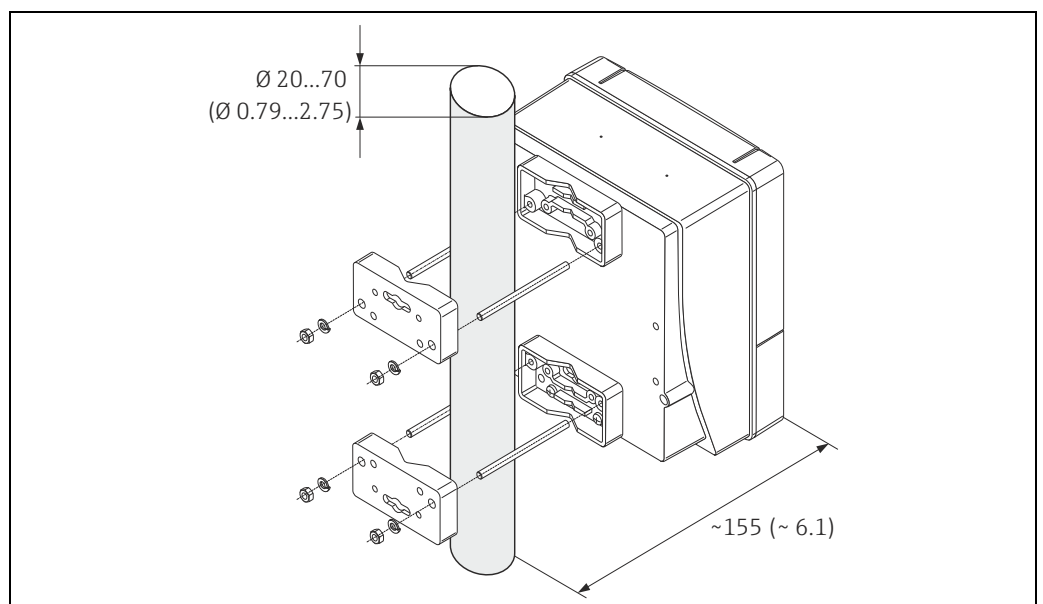

Fig. 28: Pipe mounting (wall-mount housing)

3.4 Post-installation check

Perform the following checks after installing the measuring device in the pipe:

Device condition/specifications	Notes
Is the device damaged (visual inspection)?	–
Does the device correspond to specifications at the measuring point, including process temperature and pressure, ambient temperature, minimum fluid conductivity, measuring range, etc.?	→ 100
Installation	Notes
Does the arrow on the sensor nameplate match the direction of flow through the pipe?	–
Is the position of the measuring electrode plane correct?	→ 14
Is the position of the empty pipe detection electrode correct?	→ 14
Were all screws tightened to the specified tightening torques when the sensor was installed?	→ 20
Were the correct seals installed (type, material, installation)?	→ 31
Are the measuring point number and labeling correct (visual inspection)?	–
Process environment / process conditions	Notes
Are the inlet and outlet runs respected?	Inlet run $\geq 5 \times \text{DN}$ Outlet run $\geq 2 \times \text{DN}$
Is the measuring device protected against moisture and direct sunlight?	–
Is the sensor adequately protected against vibration (attachment, support)?	Acceleration up to 2 g in accordance with IEC 600 68-2-6 → 105

4 Wiring



Warning!

- When connecting Ex-certified devices, please take note of the instructions and wiring diagrams in the Ex-specific supplement to these Operating Instructions. Should you have any questions, please contact your Endress+Hauser sales office for assistance.
- When installing remote versions, please make sure that the serial number on the sensor and the serial number on the transmitter are *identical*. Measuring errors can occur if this is not adhered to.



Note!

The device does not have an internal circuit breaker. An external switch or circuit breaker must therefore be installed which can be used to disconnect the device from the main power source.

4.1 FOUNDATION Fieldbus cable specification

4.1.1 Cable type

Twin-core cable is recommended for connecting the flowmeter to the FOUNDATION Fieldbus H1. In accordance with IEC 61158-2 (MBP), four different cable types (A, B, C, D) can be used with the FOUNDATION Fieldbus Protocol, only two of which (cable types A and B) are shielded.

- Cable types A or B are particularly preferable for new installations. Only these types have cable shielding that guarantees adequate protection from electromagnetic interference and thus the most reliable data transfer. With cable type B more than one fieldbus (with the same degree of protection) may be operated in a cable. No other circuits are permissible in the same cable.
- Practical experience has shown that cable types C and D should not be used due to the lack of shielding, since the freedom from interference generally does not meet the requirements described in the standard.

The electrical data of the fieldbus cable have not been specified. However, they determine important characteristics of the design of the fieldbus, such as distances bridged, number of users, electromagnetic compatibility, etc.

	Type A	Type B
Cable structure	Twisted pair, shielded	One or more twisted pairs, fully shielded
Wire cross-section	0.8 mm ² (AWG 18)	0.32 mm ² (AWG 22)
Loop-resistance (DC)	44 Ω/km	112 Ω/km
Characteristic impedance at 31.25 kHz	100 Ω ± 20%	100 Ω ± 30%
Attenuation constant at 39 kHz	3 dB/km	5 dB/km
Capacitive asymmetry	2 nF/km	2 nF/km
Envelope delay distortion (7.9 to 39 kHz)	1.7 μs/km	*
Shield coverage	90%	*
Max. cable length (incl. spurs >1 m)	1900 m (6233 ft)	1200 m (3937 ft)
* Not specified		

Suitable fieldbus cables (Type A) from various manufacturers for non-hazardous areas are listed below:

- Siemens: 6XV1 830-5BH10
- Belden: 3076F
- Kerpen: CeL-PE/OSCR/PVC/FRLA FB-02YS(ST)YFL

4.1.2 Maximum overall cable length

The maximum network length depends on the type of protection and the cable specifications. The overall cable length combines the length of the main cable and the length of all spurs (> 1 m / 3.28 ft). Note the following points:

- The maximum permissible overall cable length depends on the cable type used.
- If repeaters are used, the maximum permissible cable length is doubled. A maximum of three repeaters are permitted between user and master.

4.1.3 Maximum spur length

The line between the distribution box and field device is described as a spur. In the case of non-Ex applications, the max. length of a spur depends on the number of spurs (> 1 m / 3.28 ft):

Number of spurs	1 to 12	13 to 14	15 to 18	19 to 24	25 to 32
Max. length per spur	120 m (393 ft)	90 m (295 ft)	60 m (196 ft)	30 m (98 ft)	1 m (3.28 ft)

4.1.4 Number of field devices

According to IEC 61158-2 (MBP) a maximum of 32 field devices may be connected per fieldbus segment. However, this number may be restricted in certain circumstances (type of ignition protection, bus power option, current consumption of field device). A maximum of four field devices can be connected to a spur.

4.1.5 Shielding and grounding

The optimum electromagnetic compatibility of the fieldbus system is guaranteed only when system components and in particular lines are shielded and the shielding provides the most complete coverage possible. Shield coverage of 90% is ideal.

Shielding should be connected as often as possible with the reference ground. The national regulations and guidelines governing the installation of electrical equipment also apply where relevant!

Where there are large differences in potential between the individual grounding points, only one point of the shielding is connected directly with the reference ground. In systems without potential equalization, cable shielding of fieldbus systems should therefore only be grounded on one side, for example at the fieldbus supply unit or at safety barriers.



Caution!

If the cable shielding is grounded at more than one point in systems without potential equalization, network frequency equalization currents can occur that damage the bus cable or the bus shielding and substantially affect signal transmission.

4.1.6 Bus termination

The start and end of each fieldbus segment are always to be terminated with a bus terminator. With various junction boxes (non-Ex), the bus termination can be activated via a switch. If this is not the case, a separate bus terminator must be installed. Please also note the following points:

- In the case of a branched bus segment, the device furthest from the segment coupler constitutes the end of the bus.
- If the fieldbus is extended with a repeater then the extension must also be terminated at both ends.

4.1.7 Further information

General information and further notes on connections can be found on the website (www.fieldbus.org) of the Fieldbus Foundation or in the Operating Instructions "FOUNDATION Fieldbus Overview" (available at: → www.endress.com → Download).

4.2 Shielding and grounding

When planning the shielding and grounding for a fieldbus system, there are three important points to consider:

- Electromagnetic compatibility (EMC)
- Explosion protection
- Safety of the personnel

To ensure the optimum electromagnetic compatibility of systems, it is important that the system components and above all the cables, which connect the components, are shielded and that no portion of the system is unshielded. Ideally, the cable shields are connected to the normally metal housings of the connected field devices. Since these are generally connected to the protective earth, the shield of the bus cable is grounded many times. Keep the stripped and twisted lengths of cable shield to the terminals as short as possible.

This approach, which provides the best electromagnetic compatibility and personal safety, can be used without restriction in systems with good potential matching.

In the case of systems without potential matching, a power supply frequency (50 Hz) equalizing current can flow between two grounding points which, in unfavorable cases, e.g. when it exceeds the permissible shield current, may destroy the cable.

To suppress the low frequency equalizing currents on systems without potential equalization, it is therefore recommended to connect the cable shield directly to the building ground (or protective earth) at one end only and to use capacitive coupling to connect all other grounding points.



Caution!

The legal EMC requirements are fulfilled only when the cable shield is grounded on both sides!

4.3 Connecting the remote version

4.3.1 Connecting the sensor



Warning!

- Risk of electric shock. Switch off the power supply before opening the device. Do not install or wire the device while it is connected to the power supply. Failure to comply with this precaution can result in irreparable damage to the electronics.
- Risk of electric shock. Connect the protective conductor to the ground terminal on the housing before the power supply is applied.



Caution!

- Only sensors and transmitters with the same serial number may be connected with each other. Communication problems may occur if this is not adhered to.
- Risk of damaging the coil driver. Do not connect or remove the coil cable until the power supply has been switched off.

Procedure

1. Transmitter: Remove the cover from the connection compartment (a).
2. Sensor: Remove the cover from the connection housing (b).
3. Feed the signal cable (c) and coil current cable (d) through the appropriate cable entries.



Caution!

Secure the connecting cable (see "Length of connecting cable" → 19).

4. Terminate the signal and coil current cable in accordance with the table:
 Promag E/P/W → Please see the "Cable termination" table → 46
 Promag H → Please see the "Cable termination" table → 47
5. Set up the wiring between the sensor and the transmitter.
 The wiring diagram applicable to your device can be found:
 - ▶ in the relevant diagram:
 → 29 (Promag E/P/W); → 30 (Promag H)
 - ▶ in the cover of the sensor and transmitter.



Note!

The cable shields of the Promag H sensor are grounded using strain relief clamps (please see the "Cable termination" table → 47).



Caution!

Insulate the cable shields that are not connected. This eliminates the risk of short-circuits with neighboring cable shields inside the connection housing.

6. Transmitter: Secure the cover on the connection compartment (a).
7. Sensor: Mount the cover on the connection housing (b).

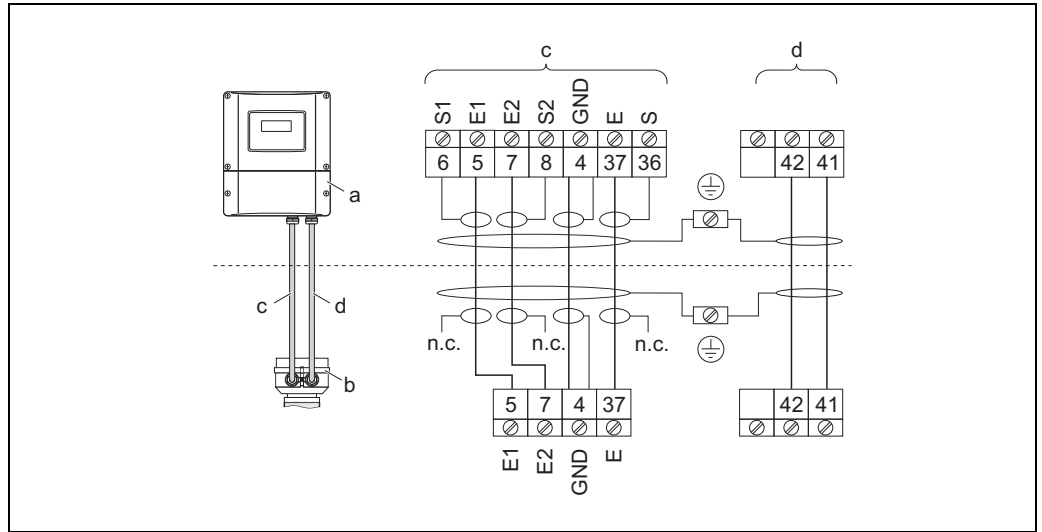

A0011722

Fig. 29: Connecting the remote version of the Promag E/P/W

- a Connection compartment, wall-mount housing
- b Connection housing, sensor
- c Signal cable
- d Coil current cable
- n.c. Not connected, insulated cable shields

n.c. Cable colors/numbers for terminals:
 5/6 = brown, 7/8 = white, 4 = green, 37/36 = yellow

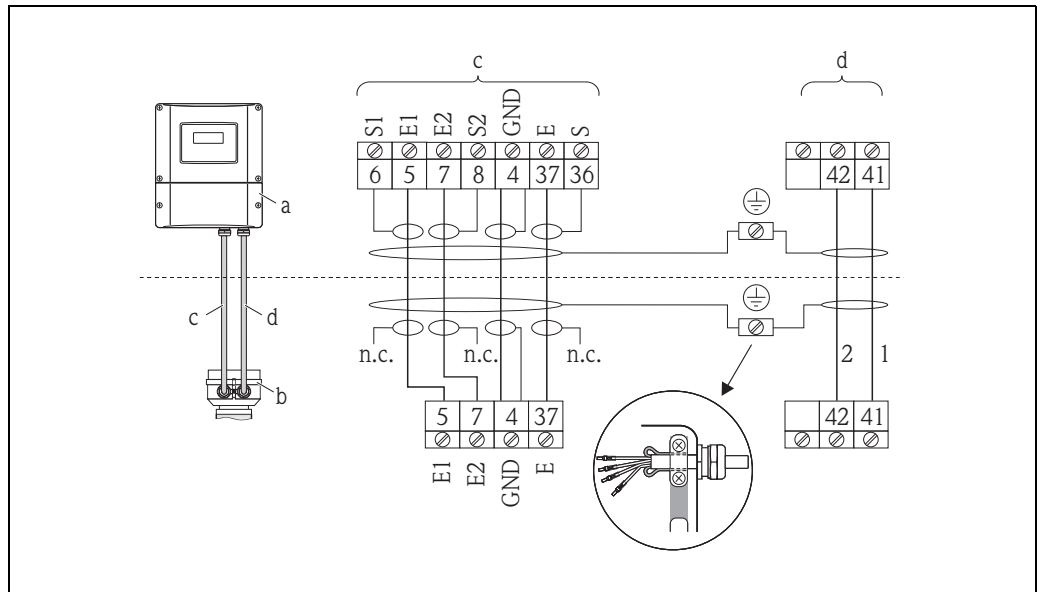

A0011747

Fig. 30: Connecting the remote version of the Promag H

- a Connection compartment, wall-mount housing
- b Connection housing, sensor
- c Signal cable
- d Coil current cable
- n.c. Not connected, insulated cable shields

n.c. Cable colors/numbers for terminals:
 5/6 = brown, 7/8 = white, 4 = green, 37/36 = yellow

**Cable termination in remote version
Promag E/P/W**

Terminate the signal and coil current cables as shown in the figure below (Detail A).
Fit the fine-wire cores with wire end ferrules (detail B: ① = red ferrules, Ø 1.0 mm; ② = white ferrules, Ø 0.5 mm)
* Stripping for reinforced cables only

Caution!

When fitting the connectors, pay attention to the following points:

- *Signal cable* → Make sure that the wire end ferrules do not touch the wire shields on the sensor side!
Minimum distance = 1 mm (exception "GND" = green cable)
- *Coil current cable* → Insulate one core of the three-core wire at the level of the core reinforcement; you only require two cores for the connection.

TRANSMITTER

Signal cable

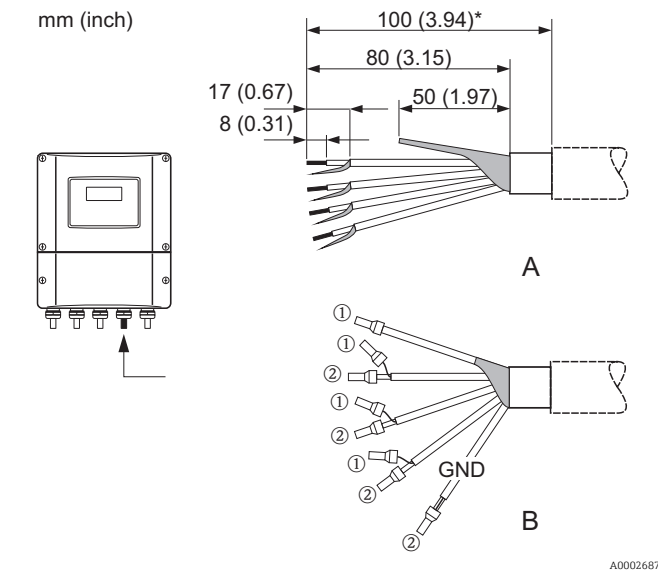

Coil current cable

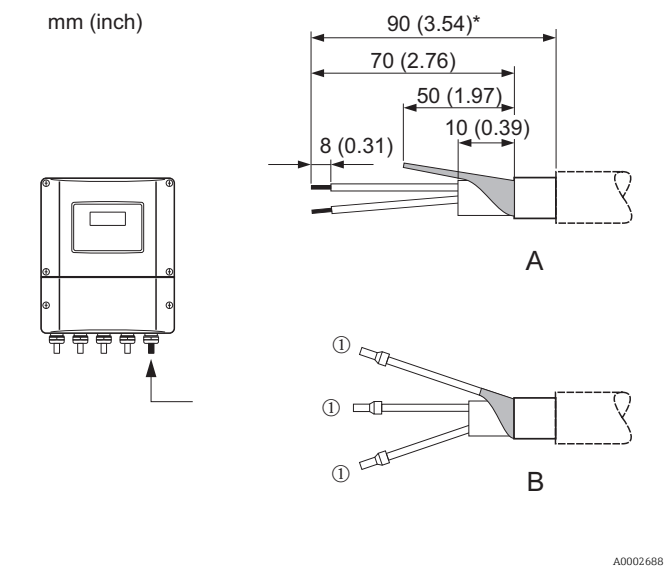

SENSOR

Signal cable

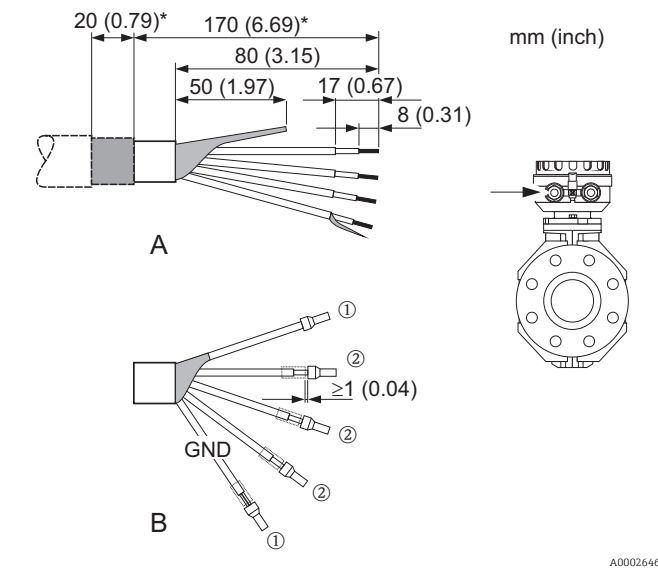

Coil current cable

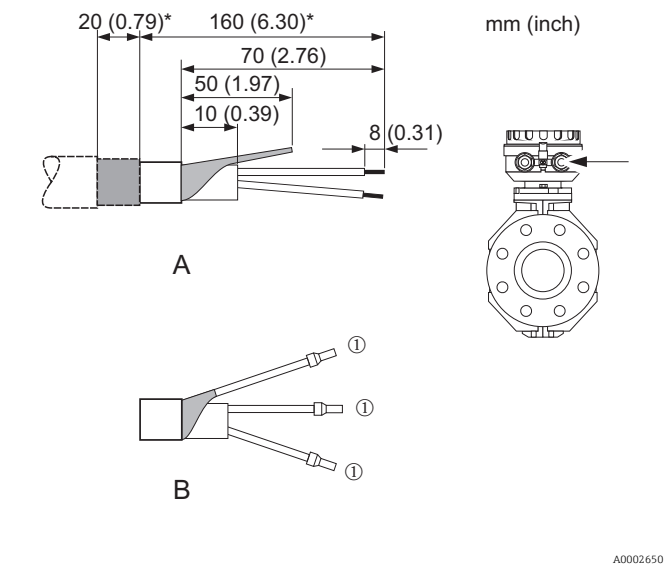

**Cable termination in remote version
Promag H**

Terminate the signal and coil current cables as shown in the figure below (Detail A).
Fit the fine-wire cores with wire end ferrules (detail B: ① = ferrules red, Ø 1.0 mm; ② = ferrule white, Ø 0.5 mm)

⚠ Caution!

When fitting the connectors, pay attention to the following points:

- *Signal cable* → Make sure that the wire end ferrules do not touch the wire shields on the sensor side!
Minimum distance = 1 mm (exception "GND" = green cable)
- *Coil current cable* → Insulate one core of the three-core wire at the level of the core reinforcement; you only require two cores for the connection.
- On the sensor side, reverse both cable shields approx. 15 mm over the outer jacket. The strain relief ensures an electrical connection with the connection housing.

TRANSMITTER

Signal cable

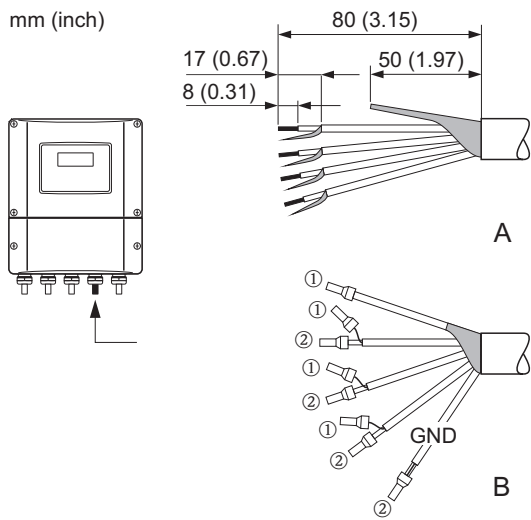

A0002686

Coil current cable

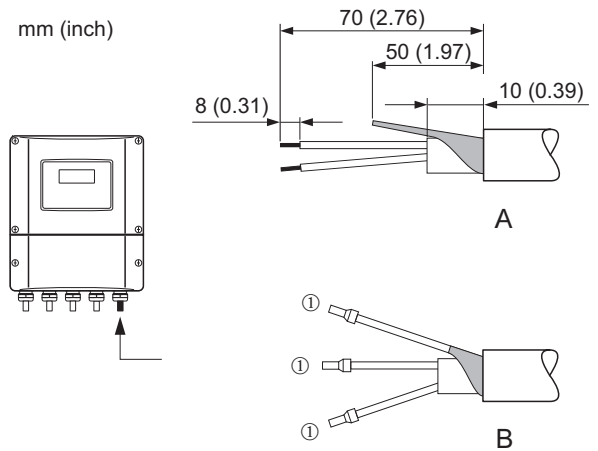

A0002684

SENSOR

Signal cable

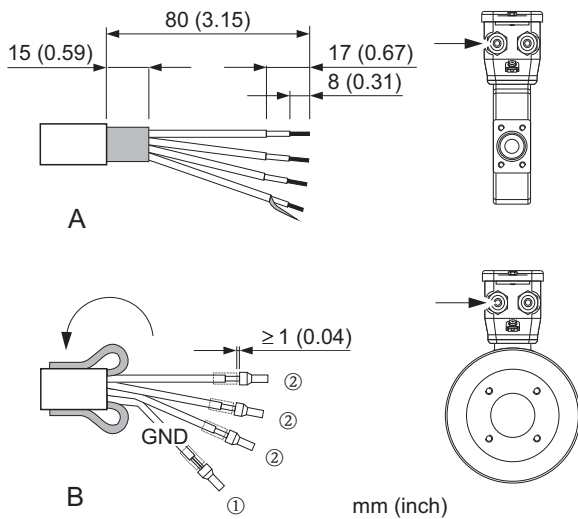

A0002647

Coil current cable

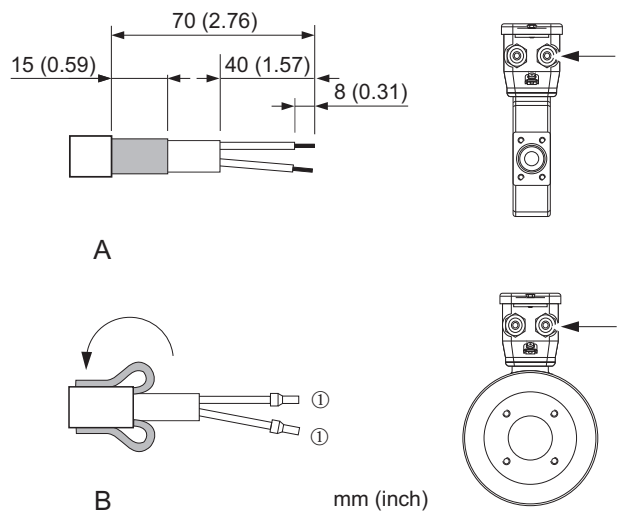

A0002648

4.3.2 Cable specifications

Signal cable

- $3 \times 0.38 \text{ mm}^2$ PVC cable with common, braided copper shield ($\varnothing \sim 7 \text{ mm}$) and individually shielded cores
- With Empty Pipe Detection (EPD): $4 \times 0.38 \text{ mm}^2$ PVC cable with common, braided copper shield ($\varnothing \sim 7 \text{ mm}$) and individually shielded cores
- Conductor resistance: $\leq 50 \text{ } \Omega/\text{km}$
- Capacitance: core/shield: $\leq 420 \text{ pF/m}$
- Operating temperature: -20 to $+80 \text{ }^\circ\text{C}$
- Conductor cross-section: max. 2.5 mm^2

Coil cable

- $2 \times 0.75 \text{ mm}^2$ PVC cable with common, braided copper shield ($\varnothing \sim 7 \text{ mm}$)
- Conductor resistance: $\leq 37 \text{ } \Omega/\text{km}$
- Capacitance: core/core, shield grounded: $\leq 120 \text{ pF/m}$
- Operating temperature: -20 to $+80 \text{ }^\circ\text{C}$
- Conductor cross-section: max. 2.5 mm^2
- Test current for cable insulation: $\geq 1433 \text{ V AC rms } 50/60 \text{ Hz}$ or $\geq 2026 \text{ V DC}$

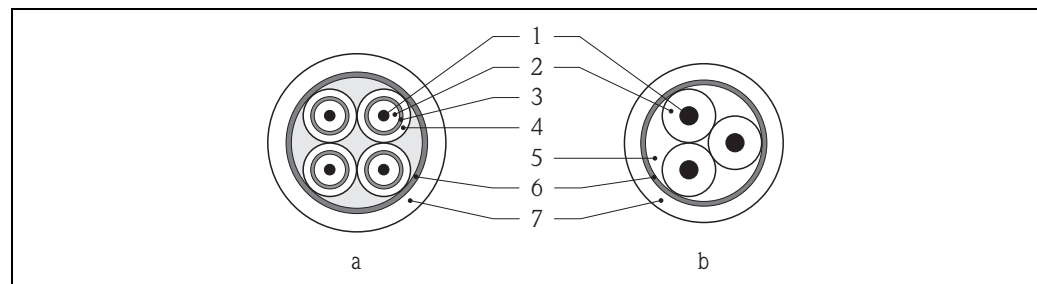

A0003194

Fig. 31: Cable cross-section

- | | |
|---|--------------------|
| a | Signal cable |
| b | Coil current cable |
| 1 | Core |
| 2 | Core insulation |
| 3 | Core shield |
| 4 | Core jacket |
| 5 | Core reinforcement |
| 6 | Cable shield |
| 7 | Outer jacket |

Reinforced connecting cables

As an option, Endress+Hauser can also deliver reinforced connecting cables with an additional reinforcing metal braid. Reinforced connecting cables should be used where cables are laid directly into the ground, where there is a risk of rodent damage to cables and where device operation should comply with the IP 68 standard of protection.

Operation in zones of severe electrical interference

The measuring device complies with the general safety requirements in accordance with EN 61010 and the EMC requirements of IEC/EN 61326.





Caution!

Grounding is by means of the ground terminals provided for the purpose inside the connection housing. Keep the stripped and twisted lengths of cable shield to the terminals as short as possible.

4.4 Connecting the measuring unit

Field instruments can be connected to the FOUNDATION Fieldbus in two ways:

- Connection via conventional cable gland →  41
- Connection using prefabricated fieldbus connector (option) →  51

4.4.1 Connecting the transmitter





Warning!

- Risk of electric shock. Switch off the power supply before opening the device. Do not install or wire the device while it is connected to the power supply. Failure to comply with this precaution can result in irreparable damage to the electronics.
- Risk of electric shock. Connect the protective earth to the ground terminal on the housing before the power supply is applied (e.g. galvanically isolated power supply SELV or PELV).
- Compare the specifications on the nameplate with the local voltage supply and frequency. Also observe the national regulations governing the installation of electrical equipment.

Procedure (→  32):

1. Unscrew the connection compartment cover (a) from the transmitter housing.
2. Feed the power supply cable (b) and fieldbus cable (d) through the appropriate cable entries.

 Note!

The device can also be supplied with the option of a ready-mounted fieldbus connector. More information on this can be found on →  51.

3. Perform wiring in accordance with the respective terminal assignment and the associated wiring diagram.

 Caution!

- Risk of damage to the fieldbus cable!
Observe the information about shielding and grounding the fieldbus cable →  43.
- We recommend that the fieldbus cable not be looped using conventional cable glands. If, at a later stage, you replace even just one measuring device, the bus communication will have to be interrupted.

 Note!

- The terminals for the fieldbus connection (26/27) have integrated reverse polarity protection. This ensures correct signal transmission via the fieldbus even if lines are transposed.
 - Conductor cross-section: max. 2.5 mm²
 - Between the stripped fieldbus cable shielding and the ground terminal (e), the cable shielding should not exceed a length of 5 mm.
4. Screw the cover of the connection compartment (a) back onto the transmitter housing.

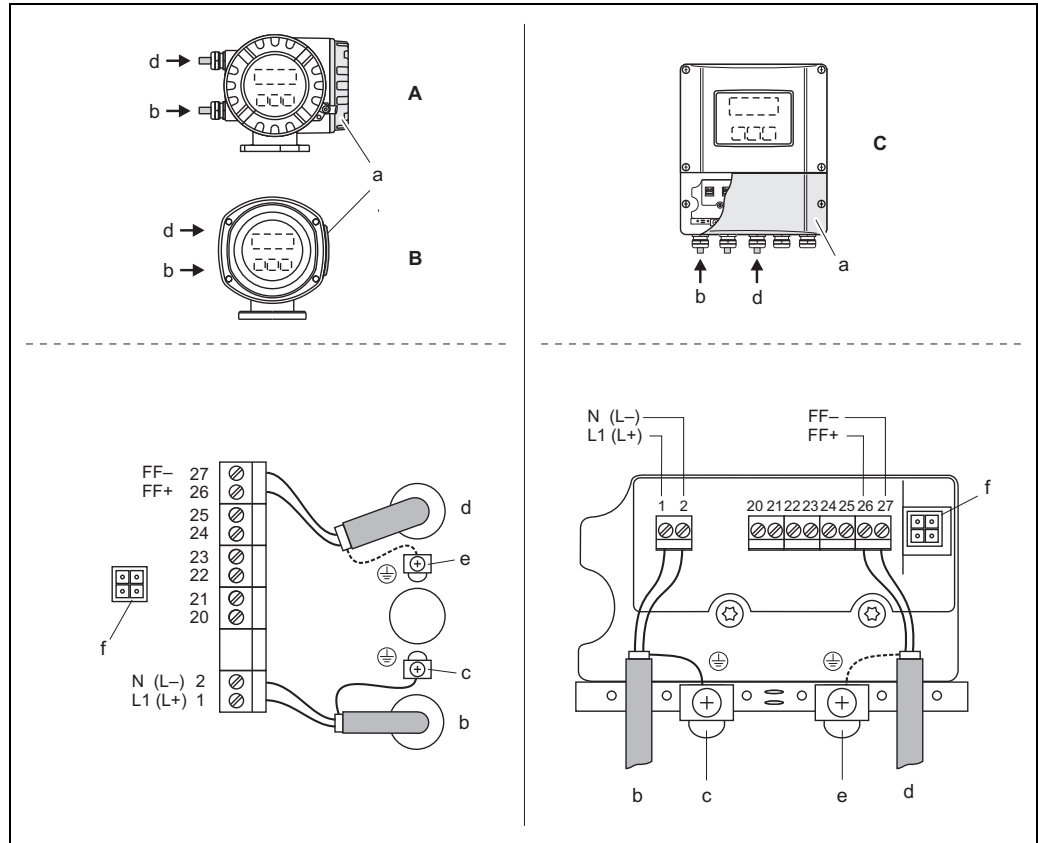

a0004723

Fig. 32: Connecting the transmitter, cable cross-section: max. 2,5 mm²

- A View A (field housing)
 B View B (stainless steel housing)
 C View C (wall-mount housing)

a Connection compartment cover

b Cable for power supply
 Terminal no. 1:
 - L1 for AC, L+ for DC

Terminal no. 2:
 - N for AC, L- for DC

c Ground terminal for protective ground

d Fieldbus cable

Terminal no. 26:
 - FF+ (with reverse polarity protection)

Terminal no. 27:
 - FF- (with reverse polarity protection)

e Fieldbus cable shield ground terminal

Observe the following:

- The shielding and grounding of the fieldbus cable → 43
- Ensure the stripped and twisted lengths of cable shield to the ground terminal are as short as possible

f Service connector for connecting the service interface FXA193 (Fieldcheck, FieldCare)

4.4.2 Fieldbus connector

The connection technology of FOUNDATION Fieldbus allows measuring devices to be connected to the fieldbus via uniform mechanical connections such as T-boxes, junction boxes, etc.

This connection technology using prefabricated distribution modules and plug-in connectors offers substantial advantages over conventional wiring:

- Field devices can be removed, replaced or added at any time during normal operation. Communication is not interrupted.
- Installation and maintenance are significantly easier.
- Existing cable infrastructures can be used and expanded instantly, e.g. when constructing new star distributors using 4-channel or 8-channel distribution modules.

The device can therefore be supplied with the option of a ready-mounted fieldbus connector. Fieldbus connectors for retrofitting can be ordered from Endress+Hauser as a spare part →  78.

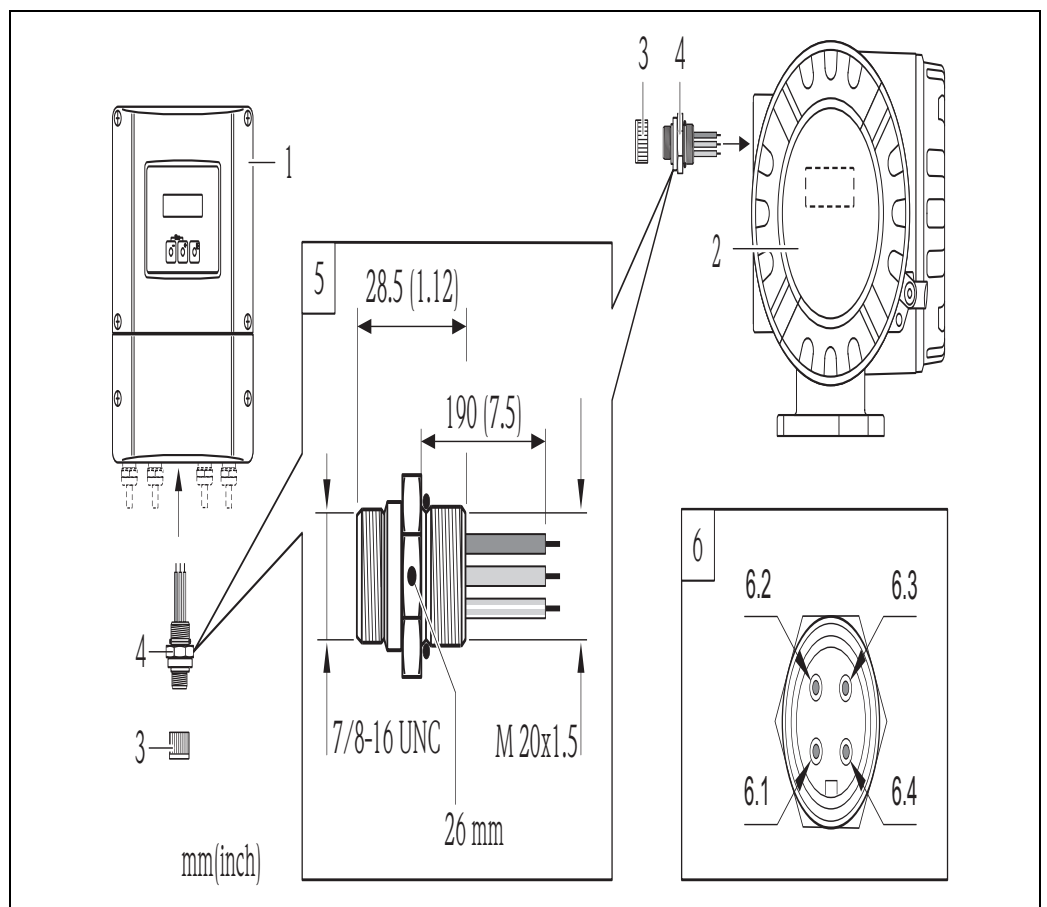



Fig. 33: Connector for connecting to the FOUNDATION Fieldbus

- A Wall-mount housing
 B Aluminum field housing
 C Protection cap for connector
 D Fieldbus connector
- 1 Protection cap for connector
 2 Field bus connector (pin assignment/color codes)
 2.1 Brown wire: FF + (Terminal 26)
 2.2 Blue wire: FF - (Terminal 27)
 2.3 Not assigned
 2.4 Green/yellow: ground (notes on connection →  50)

Technical data, connector:

- Degree of protection IP 67
- Ambient temperature: -40 to +150 °C (-40 to +302 °F)

4.4.3 Terminal assignment



Note!

The electrical characteristic quantities are listed in the "Technical data" section → 100.

Order version	Terminal No. (inputs / outputs)			
	20 (+) / 21 (-)	22 (+) / 23 (-)	24 (+) / 25 (-)	26 = FF + ¹⁾ 27 = FF - ¹⁾
53***_*****G	-	-	-	FOUNDATION Fieldbus Ex i
53***_*****K	-	-	-	FOUNDATION Fieldbus

¹⁾ With integrated reverse polarity protection

4.5 Potential equalization



Warning!

The measuring system must be included in potential equalization.

Perfect measurement is only ensured when the medium and the sensor have the same electrical potential. Most Promag sensors have a reference electrode installed as standard, which guarantees the required potential equalization.

The following must also be taken into account for potential equalization:

- Company-internal grounding guidelines
- Operating conditions such as material/grounding of piping etc. (see table)

4.5.1 Potential equalization, Promag E/P/W

Reference electrode available as standard

4.5.2 Potential equalization, Promag H

No reference electrode available!

There is always one electrical connection to the fluid via the metallic process connection.



Caution!

When using process connections made of plastic, potential equalization must be guaranteed through the use of grounding rings → 24.

The necessary grounding rings may be ordered separately as an accessory from Endress+Hauser (→ 78).

4.5.3 Connection examples for potential equalization

Standard case

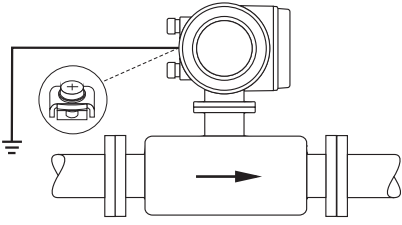
Operating conditions	Potential equalization
<p>When using the measuring device in:</p> <ul style="list-style-type: none"> ▪ metallic, grounded piping <p>Potential equalization is carried out via the ground terminal of the transmitter.</p> <p> Note! For installation in metal pipes, it is advisable to connect the ground terminal of the transmitter housing to the piping.</p>	 <p style="text-align: right; font-size: small;">A0011892</p> <p><i>Fig. 34: Via the transmitter's ground terminal</i></p>

Special cases

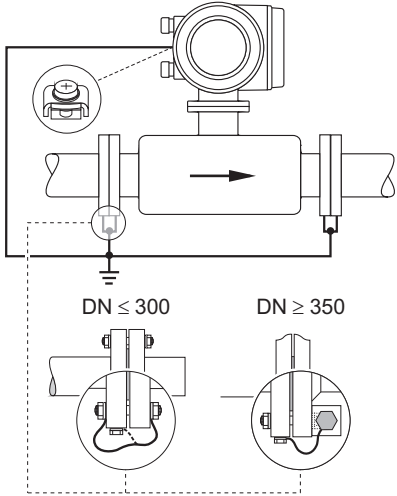
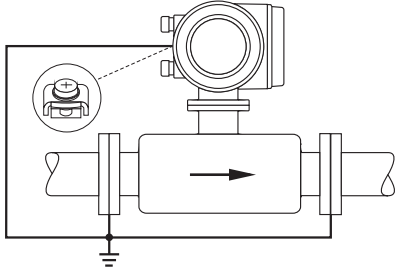
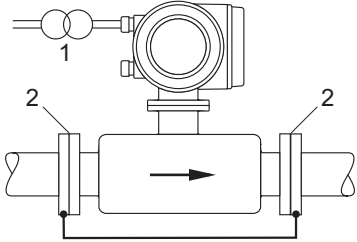
Operating conditions	Potential equalization
<p>When using the measuring device in:</p> <ul style="list-style-type: none"> metallic, ungrounded piping <p>This type of connection occurs when:</p> <ul style="list-style-type: none"> the usual potential equalization cannot be guaranteed extremely high equalizing currents are expected <p>A ground cable (copper wire, at least 6 mm² (0.0093 in²)) is used to connect both sensor flanges to the respective pipe flange and ground them. Connect the transmitter or sensor connection housing, as applicable, to ground potential by means of the ground terminal provided for the purpose.</p> <p>The installation of the ground cable depends on the nominal diameter:</p> <ul style="list-style-type: none"> DN ≤ 300 (12"): The ground cable is in direct connection with the conductive flange coating and is secured by the flange screws. DN ≥ 350 (14"): The ground cable connects directly to the metal transport bracket. <p> Note! The ground cable for flange-to-flange connections can be ordered separately as an accessory from Endress+Hauser.</p>	 <p style="text-align: right;">A0011893</p> <p><i>Fig. 35: Via the transmitter's ground terminal and the pipe flanges</i></p>
<p>When using the measuring device in:</p> <ul style="list-style-type: none"> Plastic pipes Isolating lined pipes <p>This type of connection occurs when:</p> <ul style="list-style-type: none"> the usual potential equalization cannot be guaranteed extremely high equalizing currents are expected <p>Potential equalization takes place using additional ground disks, which are connected to the ground terminal via a ground cable (copper wire, min. 6 mm² (0.0093 in²)). When installing the ground disks, please comply with the enclosed Installation Instructions.</p>	 <p style="text-align: right;">A0011895</p> <p><i>Fig. 36: Via the transmitter's ground terminal and the optionally available ground disks</i></p>
<p>When using the measuring device in:</p> <ul style="list-style-type: none"> pipes with cathodic protection <p>The device is installed in the pipeline in such a way that it is potential-free.</p> <p>Using a ground cable (copper wire, min. 6 mm² (0.0093 in²)), only the two pipe flanges are connected. When doing so, the ground cable is mounted directly on the conductive flange coating using flange screws.</p> <p>Please note the following during installation:</p> <ul style="list-style-type: none"> The relevant regulations for potential-free installations must be observed. There must not be an electrically conductive connection between the piping and the device. The mounting material must be able to withstand the relevant torques. 	 <p style="text-align: right;">A0011896</p> <p><i>Fig. 37: Potential equalization and cathodic protection</i></p> <p>1 Isolation transformer power supply 2 Electrically isolated</p>

4.6 Degree of protection

The devices fulfill all the requirements for IP 67 (NEMA 4X).

Compliance with the following points is mandatory following installation in the field or servicing, in order to ensure that IP 67 protection (NEMA 4X) is maintained:

- The housing seals must be clean and undamaged when inserted into their grooves. The seals must be dried, cleaned or replaced if necessary.
- All housing screws and screw covers must be firmly tightened.
- The cables used for connection must be of the specified external diameter → 103.
- Tighten cable glands to prevent leakages.
- The cables must loop down before they enter the cable entries ("water trap"). This arrangement prevents moisture penetrating the entry. Always install the measuring device in such a way that the cable entries do not point up.
- Close off unused cable entries using suitable insert plugs.
- Do not remove the grommet from the cable entry.

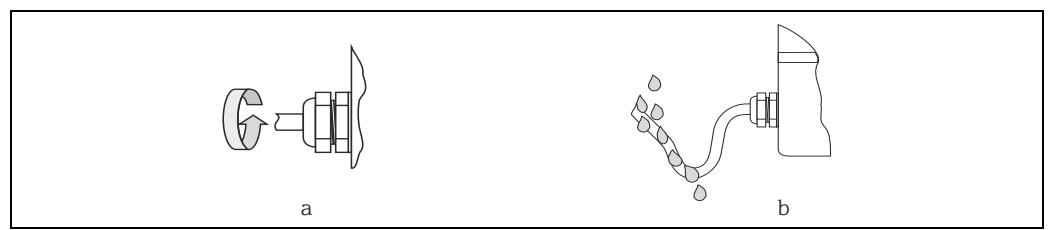

Fig. 38: Installation instructions, cable entries



Caution!

Do not loosen the screws of the sensor housing as otherwise the degree of protection guaranteed by Endress+Hauser no longer applies.







Note!

The sensor can also be supplied with IP 68 rating (permanent immersion in water to a depth of 3 meters). In this case the transmitter must be installed remote from the sensor.

4.7 Post-connection check



Perform the following checks after completing electrical installation of the measuring device:

Device condition and specifications	Notes
Are cables or the device damaged (visual inspection)?	–
Electrical connection	Notes
Do the cables have adequate strain relief?	–
Is the cable type route completely isolated? Without loops and crossovers?	–
Are the power-supply and signal cables correctly connected?	See the wiring diagram inside the cover of the connection compartment
Are all screw terminals firmly tightened?	–
Have the measures for grounding/potential equalization been correctly implemented?	→  53
Are all cable entries installed, firmly tightened and correctly sealed? Cables looped as "water traps"?	→  55
Are all housing covers installed and firmly tightened?	–
Electrical connection of FOUNDATION Fieldbus H1	Notes
Are all the connecting components (T-boxes, junction boxes, connectors, etc.) correctly connected with each other?	–
Has each fieldbus segment been terminated at both ends with a bus terminator?	–
Has the max. length of the fieldbus cable been observed in accordance with the FOUNDATION Fieldbus specifications?	→  42
Has the max. length of the spurs been observed in accordance with the FOUNDATION Fieldbus specifications?	→  42
Is the fieldbus cable fully shielded (90 %) and correctly grounded?	→  43

5 Operation

5.1 Quick operation guide

The user has a number of options for configuring and commissioning the device:

1. Local display (option) →  58
The local display enables you to read all important variables directly at the measuring point, configure device-specific parameters in the field and perform commissioning.
2. Operating programs →  64
The FF functions and device-specific parameters are configured primarily via the fieldbus interface. Special configuration and operating programs from various manufacturers are available to users for this purpose.
3. Jumpers for diverse hardware settings →  66
Jumpers on the I/O board provide the means of setting the following hardware parameters for the FOUNDATION Fieldbus:
 - ▶ Enabling/disabling the simulation mode in the function blocks (e.g. AI, DO function block)
 - ▶ Switching the hardware write protection on and off

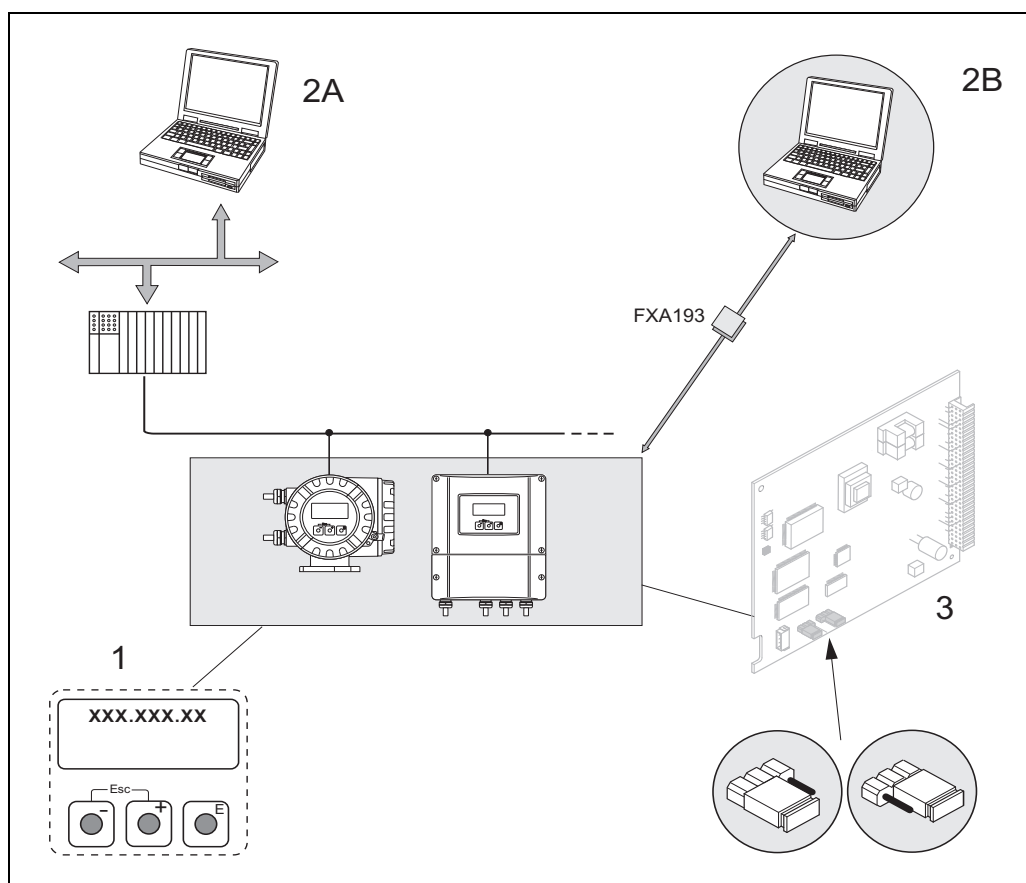

Fig. 39: FOUNDATION Fieldbus operating options

- 1 Local display for device operation in the field (option)
- 2A Configuration/operating programs for operating via the FOUNDATION Fieldbus (FF functions, device parameters)
- 2B Configuration/operating program for operating via the FXA193 service interface (e.g. FieldCare)
- 3 Jumper/miniature switches for hardware settings (write protection, simulation mode)

5.2 Local display

5.2.1 Display and operating elements

The local display enables you to read important parameters directly at the measuring point or to configure your device using the "Quick Setup" or the function matrix.

The display consists of four lines; this is where measured values and/or status variables (direction of flow, empty pipe, bar graph, etc.) are displayed. You can change the assignment of display lines to variables at will in order to customize the display to suit your needs and preferences (→ see the "Description of Device Functions" manual).

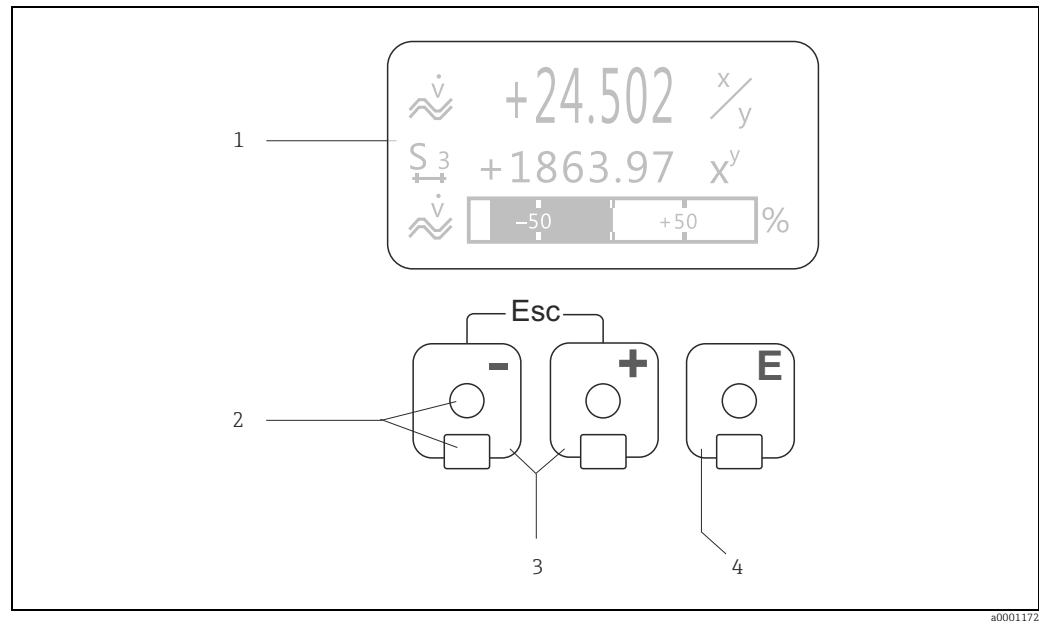

Fig. 40: Display and operating elements

- 1 **Liquid crystal display**
The backlit, four-line liquid crystal display shows measured values, dialog texts, fault messages and notice messages. The display as it appears when normal measuring is in progress is known as the HOME position (operating mode display).
Display
- 2 **Optical sensors for Touch Control**
- 3 **+/- keys**
 - HOME position → Direct access to totalizer values and actual values of inputs/outputs
 - Enter numerical values, select parameters
 - Select different blocks, groups and function groups within the function matrix

Press the +/- keys simultaneously to trigger the following functions:

 - Exit the function matrix step by step → HOME position
 - Press and hold down the +/- keys for longer than 3 seconds → Return directly to the HOME position
 - Cancel data entry
- 4 **E/ key (Enter key)**
 - HOME position → Entry into the function matrix
 - Save the numerical values you input or settings you change

5.2.2 Display (operating mode)

The display area consists of three lines in all; this is where measured values are displayed, and/or status variables (direction of flow, bar graph, etc.). You can change the assignment of display lines to variables at will in order to customize the display to suit your needs and preferences (→ see the "Description of Device Functions" manual).

Multiplex mode:

A maximum of two different display variables can be assigned to each line. Variables multiplexed in this way alternate every 10 seconds on the display.

Error messages:

Display and presentation of system/process errors →  63

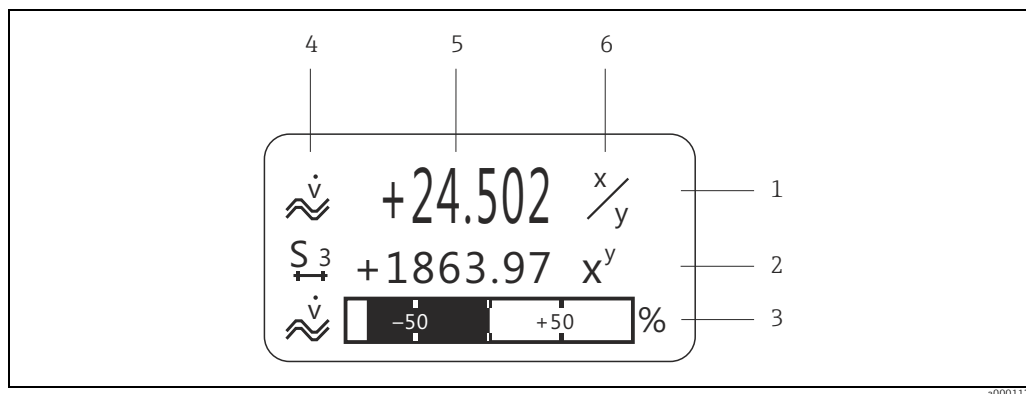





Fig. 41: Typical display for normal operating mode (HOME position)



- 1 Main line shows main measured values, e.g. flow
- 2 Supplementary line shows supplementary measured or status variables, e.g. totalizer reading.
- 3 Information line shows additional information on measured or status variables, e.g. bar graph representation of the full scale value attained by the flow rate
- 4 "Info icons" field shows additional information in the form of icons on the measured values displayed. A complete overview of all icons and their meaning can be found on →  60
- 5 "Measured values" field shows the current measured values
- 6 "Engineering unit" field shows the engineering units and time units defined for the current measured values.



Note!

In the HOME position, you can use the   keys to call up a list containing the following information:







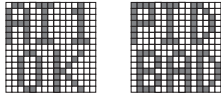

- Totalizer values (including overflow)
- Tag name (DEVICE PD-TAG)

  key → queries individual values in the list

Simultaneously press Esc key () → Return to the HOME position

5.2.3 Icons

The icons which appear in the field on the left make it easier to read and recognize measured variables, device status, and error messages.

Icon	Meaning	Icon	Meaning
S	System error	P	Process error
	Fault message (with impact on outputs)	!	Notice message (without impact on outputs)
Σ 1...n	Totalizer 1...n	AI 1 (...n)	Analog Input function block 1 (...n), output value OUT
PID	PID function block: A PID function block value as listed below is output, depending on the assignment of the lines in the local display: - OUT value (= manipulated variable) - IN value (= control variable) - CAS_IN value (= external set point)		
The messages listed below describe the status of the OUT value of the Analog Input function block and the value assigned to the PID function block.			
OK	Status = GOOD (valid)	UNC	Status = UNCERTAIN (conditionally valid)
BAD	Status = BAD (invalid)	Example:  <small>a0006255</small>	
 <small>a0001182</small>	Measuring mode: SYMMETRY (bidirectional)	 <small>a0001183</small>	Measuring mode: STANDARD
 <small>a0001184</small>	Totalizer counting mode: BALANCE (forward and reverse flow)	 <small>a0001185</small>	Totalizer counting mode: forward
 <small>a0001186</small>	Totalizer counting mode: reverse		
 <small>a0001188</small>	Volume flow	 <small>a0001195</small>	Mass flow

5.3 Brief Operating Instructions for the function matrix



Note!

- See the general notes → 62
 - Function descriptions → See the "Description of Device Functions" manual
1. HOME position → **E** → Enter the function matrix
 2. **+/-** → Select a block (e.g. MEASURED VARIABLES) → **E**
 3. **+/-** → Select a group (e.g. SYSTEM UNITS) → **E**
 4. **+/-** → Select a function group (e.g. CONFIGURATION) → **E**
 5. Select a function (e.g. UNIT VOLUME FLOW) and change parameters/enter numerical values:
 - +/-** → Select or enter release code, parameters, numerical values
 - E** → Save entries
 6. Exit the function matrix:
 - Press and hold down Esc key (**Esc**) for longer than 3 seconds → HOME position
 - Repeatedly press Esc key (**Esc**) → Return step by step to HOME position

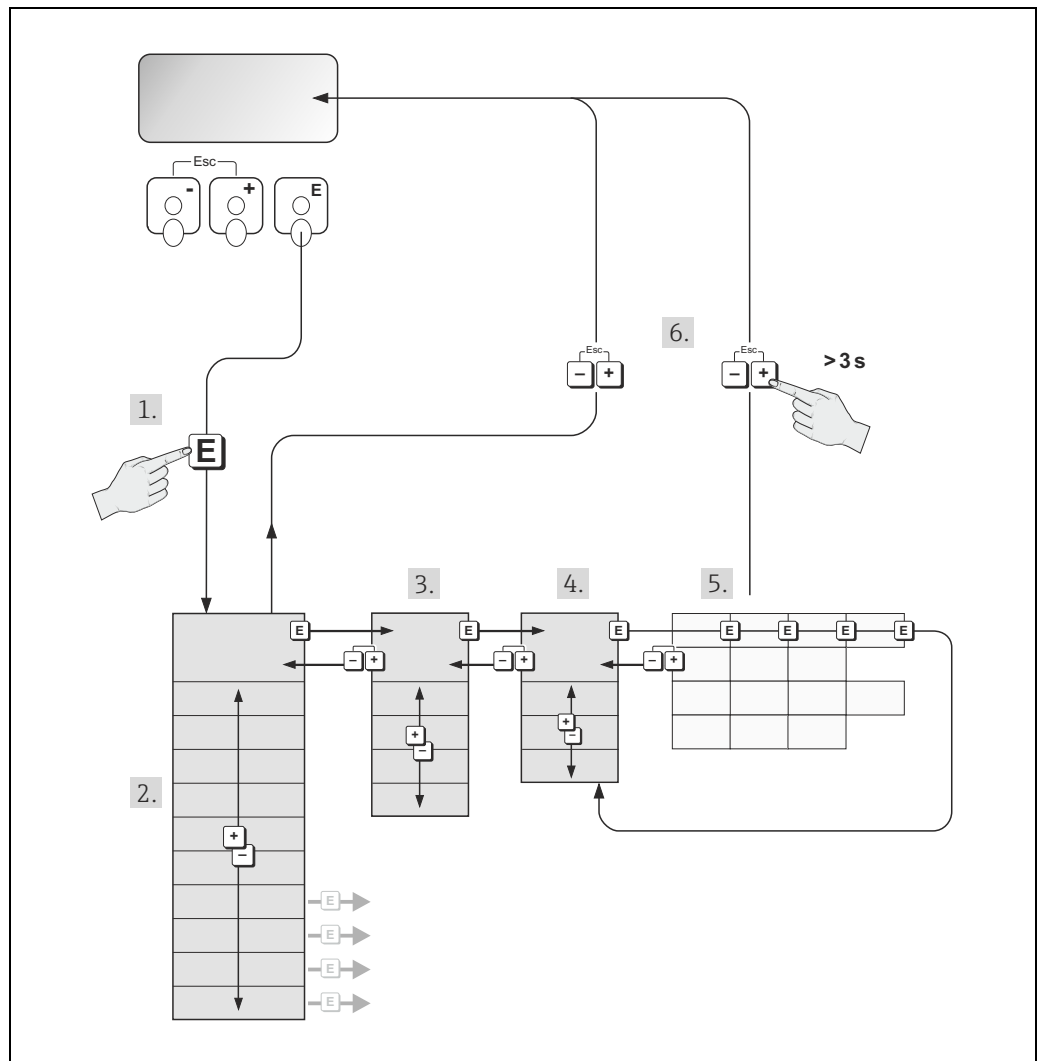





Fig. 42: Selecting functions and configuring parameters (function matrix)

a00012.10

5.3.1 General notes

The Quick Setup menu is adequate for commissioning with the necessary standard settings. Complex measuring operations on the other hand necessitate additional functions that you can configure as necessary and customize to suit your process parameters. The function matrix, therefore, comprises a multiplicity of additional functions which, for the sake of clarity, are arranged on a number of menu levels (blocks, groups, and function groups).

Comply with the following instructions when configuring functions:

- You select functions as described →  61.
 - Each cell in the function matrix is identified by a numerical or letter code on the display.
- You can switch off certain functions (OFF). If you do so, related functions in other function groups will no longer be displayed.
- Certain functions prompt you to confirm your data entries. Press / to select "SURE | YES |" and press  again to confirm. This saves your setting or starts a function, as applicable.
- Return to the HOME position is automatic if no key is pressed for 5 minutes.
- Programming mode is automatically disabled if you do not press a key within 60 seconds following automatic return to the HOME position.



Caution!

All functions are described in detail, including the function matrix itself, in the "Description of Device Functions" manual, which is a separate part of these Operating Instructions.



Note!



- The transmitter continues to measure while data entry is in progress, i.e. the current measured values are output via the signal outputs in the normal way.
- If the power supply fails, all preset and parameterized values remain safely stored in the EEPROM.

5.3.2 Enabling the programming mode

The function matrix can be disabled. Disabling the function matrix rules out the possibility of inadvertent changes to device functions, numerical values or factory settings. A numerical code (factory setting = 53) has to be entered before settings can be changed.

If you use a code number of your choice, you exclude the possibility of unauthorized persons accessing data (→ "Description of Device Functions" manual).

Comply with the following instructions when entering codes:

- If programming is disabled and the / keys are pressed in any function, a prompt for the code automatically appears on the display.
- If "0" is entered as the customer's code, programming is always enabled.
- The Endress+Hauser service organization can be of assistance if you mislay your personal code.



Caution!

- Changing certain parameters such as all sensor characteristics, for example, influences numerous functions of the entire measuring system, particularly measuring accuracy. There is no need to change these parameters under normal circumstances and consequently, they are protected by a special code known only to the Endress+Hauser service organization. Please contact Endress+Hauser first if you have any questions.
- With FF, programming is enabled separately in the Transducer Blocks.

5.3.3 Disabling the programming mode

Programming mode is disabled if you do not press a key within 60 seconds following automatic return to the HOME position.

You can also disable programming in the ACCESS CODE function by entering any number (other than the customer's code).

5.4 Error messages

5.4.1 Type of error

Errors which occur during commissioning or measuring operation are displayed immediately. If two or more system or process errors occur, the error with the highest priority is the one shown on the display.

The measuring system distinguishes between two types of error:

- **System errors:** This group comprises all device errors, e.g. communication errors, hardware errors, etc. → 85
- **Process error:** This group includes all application errors e.g. empty pipe, etc. → 89

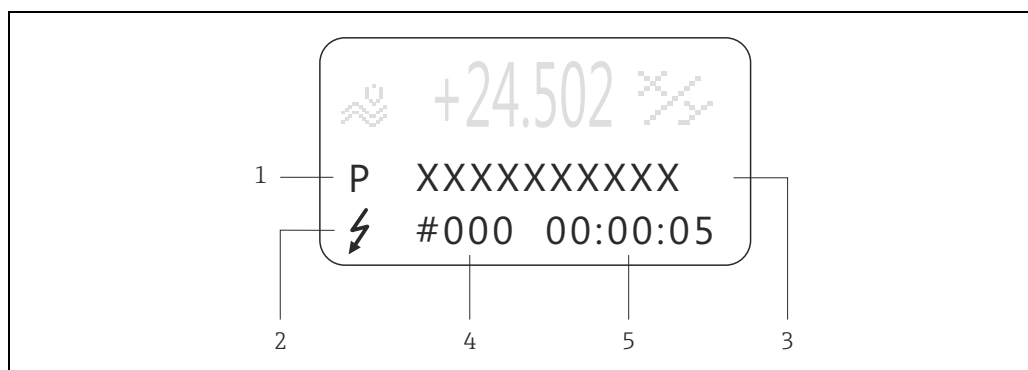

Fig. 43: Error messages on the display (example)

- 1 Error type: P = process error, S = system error
- 2 Error message type: ⚡ = fault message, ! = notice message
- 3 Error designation
- 4 Error number
- 5 Duration of most recent error occurrence (hours : minutes : seconds)

5.4.2 Error message type

The device always assigns system and process errors to two error message types (fault or notice message), with the result that they are evaluated differently → 80.

Critical system errors, e.g. module defects, are always identified and displayed as "fault messages" by the measuring device.

Notice message (!)

- The error in question has no effect on the current operation.
- Displayed as → exclamation mark (!), error type (S: system error, P: process error)
- FOUNDATION Fieldbus → Notice messages are transmitted to downstream function blocks or higher-level process control systems using the "UNCERTAIN" status of the output value OUT (AI Block).

Fault message (⚡)

- The error in question interrupts or stops the current operation.
- Displayed as → lightning flash (⚡), error type (S: system error, P: process error)
- FOUNDATION Fieldbus → Fault messages are transmitted to downstream function blocks or higher-level process control systems using the "BAD" status of the output value OUT (AI Block).

5.5 Operating programs

5.5.1 "FieldCare" operating program

FieldCare is Endress+Hauser's FDT-based plant asset management tool and enables the configuration and diagnosis of intelligent field devices. Through the use of status information, you also avail of a simple but effective tool for monitoring devices. The Proline flowmeters are accessed via a service interface e.g. service interface FXA193.

5.5.2 Operating with the FF configuration programs

The user can obtain special configuration and operating programs offered by the different manufacturers for use in configuration. These can be used for configuring both the FF functions and all the device-specific parameters. The predefined function blocks allow uniform access to all the network and fieldbus device data.

A step-by-step description of the procedure for commissioning the FF functions is given on →  68, along with the configuration of device-specific parameters.

General information on FOUNDATION Fieldbus is provided in the Operating Instructions "FOUNDATION Fieldbus Overview" (BA013S) available at: → www.endress.com → Download.

System files

You will need the following files for commissioning and network configuration:

- Commissioning → Device description (Device Description: *.sym, *.ffo)
- Network configuration → CFF file (Common File Format: *.cff)

You can obtain these files as follows:

- Free of charge from the internet → www.endress.com
- From Endress+Hauser stating the order number (No. 56003896)
- Via the Fieldbus Foundation Organization → www.fieldbus.org



Note!

Ensure you use the correct system files for linking the field devices into the host system. Appropriate version information can be called up via the following functions/parameters:

Local display:

- HOME → BASIC FUNCTION → FOUND. FIELDBUS → INFORMATION → DEVICE REVISION (6243)
- HOME → BASIC FUNCTION → FOUND. FIELDBUS → INFORMATION → DD REVISION (6244)

FF configuration program:

- Resource Block → Parameter DEV_REV
- Resource Block → Parameter DD_REV

Example (with local display):

Displayed in the DEVICE REVISION (6243) function → 04

Displayed in the DD REVISION (6244) function → 01

Device description file (DD) required → 0401.sym / 0401.ffo

5.5.3 Current device description files

The following table illustrates the suitable device description file for the operating tool in question and then indicates where these can be obtained.

FOUNDATION Fieldbus protocol:

Valid for software	3.00.XX	→ "Device software" function (8100)
FOUNDATION Fieldbus device data		
Manufacturer ID:	11 _{hex} (ENDRESS+HAUSER)	→ "Manufact ID" function (6040)
Device ID:	1042 _{hex}	→ "Device ID" function (6041)
FOUNDATION Fieldbus version data	Device Revision 4/DD Revision 1	
Software release	10.2009	
Operating program:	Sources for obtaining device descriptions/program updates::	
Device Description (DD) and Capability File (CFF)	<ul style="list-style-type: none"> ■ www.endress.com (→ Download → Software → Driver) ■ CD-ROM (Endress+Hauser order number: 56003896) ■ www.fieldbus.org 	
Device driver for the FF host systems::	Sources for obtaining:	
ABB (FieldController 800)	www.abb.com	
Allen Bradley (Control Logix)	See FF standard device driver	
Emerson (Delta V)	www.easydeltav.com	
Endress+Hauser (ControlCare)	See FF standard device driver	
Honeywell (Experion PKS)	www.honeywell.com	
SMAR (System 302)	See FF standard device driver	
Yokogawa (CENTUM CS 3000)	www.yokogawa.com	
Device driver for further FOUNDATION Fieldbus operating tools:	Sources for obtaining updates:	
Handheld terminal DXR375	<ul style="list-style-type: none"> ■ www.fieldcommunicator.com <p> Note! The device drivers can be added and updated via the 375 Field Communicator easy upgrade program utility.</p>	

Operation via the service protocol:

Tester/simulator::	Sources for obtaining updates:
Fieldcheck	<ul style="list-style-type: none"> ■ Update via FieldCare using the Flow Device FXA193/291 DTM in the Fieldflash module

5.6 FOUNDATION Fieldbus hardware settings

5.6.1 Switching hardware write protection on and off

Two jumpers on the I/O board provide the means of activating or deactivating hardware write protection and simulation mode (for AI and DO function block).



Warning!

Risk of electric shock. Exposed components carry dangerous voltages. Make sure that the power supply is switched off before you remove the cover of the electronics compartment.

1. Switch off power supply.
2. Remove the I/O board → 92.
3. Configure the hardware write protection and simulation mode accordingly with the aid of the jumpers (see Figure).
4. Installation of the I/O board is the reverse of the removal procedure.

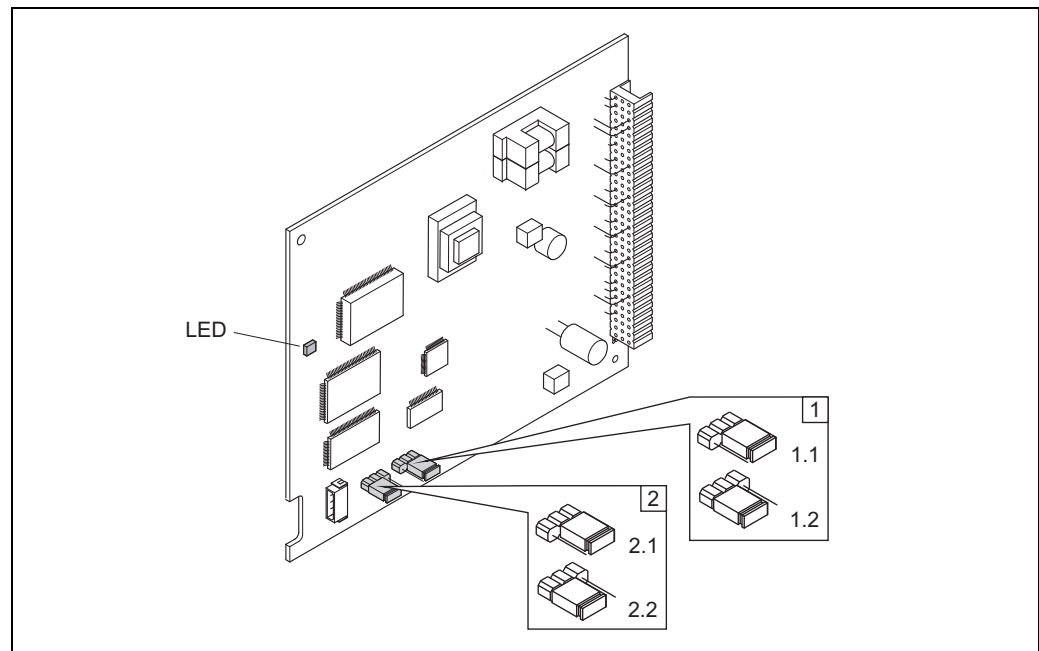

A0004731

Fig. 44: Hardware configuration (I/O board)

- 1 Jumper for switching on/off the write protection:
- 1.1 Write protection switched off (default value) = write access to device functions via FF interface is possible
 - 1.2 Write protection switched on (default value) = write access to device functions via FF interface is not possible
- 2 Jumper for simulation mode:
- 2.1 Simulation mode enabled (default value) = simulation in Analog Input function block or in Discrete Output function block is possible
 - 2.2 Simulation mode disabled = simulation in Analog Input function block or in Discrete Output function block is not possible
- LED LED:
- Continuously lit → Ready (no communication via FF active)
 - Not lit → Not ready for operation
 - Flashes slowly → Ready (communication via FF active)
 - Flashes quickly → Device failure present (error message type "fault message") → 80

6 Commissioning

6.1 Function check

Make sure that all final checks have been completed before you start up your measuring point:

- Checklist for "Post-installation check" →  40
- Checklist for "Post-connection check" →  56

6.2 Switching on the measuring device

Once the connection checks have been successfully completed, it is time to switch on the power supply. The device is now operational.

The measuring device performs a number of post switch-on self-tests. As this procedure progresses the following sequence of messages appears on the local display:

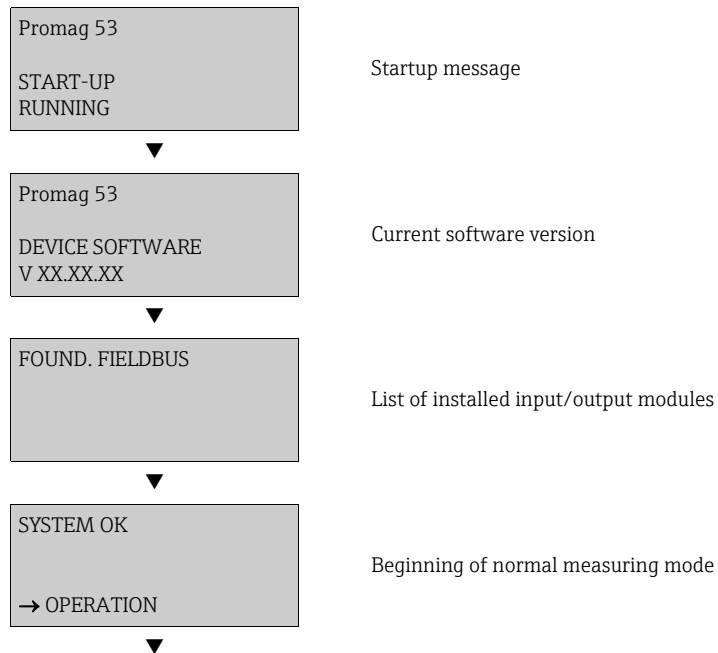

Normal measuring mode commences as soon as startup completes.

Various measured value and/or status variables appear on the display (HOME position).



Note!

If startup fails, an error message indicating the cause is displayed.

6.3 Commissioning using FOUNDATION Fieldbus

Note the following points:

- The files required for commissioning and network configuration can be obtained as described on → [64](#).
- The device is identified by the FOUNDATION Fieldbus in the host or configuration system via the device ID (DEVICE_ID). The DEVICE_ID is a combination of the manufacturer ID, device type and device serial number. It is unique and can never be duplicated. The DEVICE_ID of Promag 53 is composed as follows:

```
DEVICE_ID = 452B481042-XXXXXXXXXXXX
452B48 = Endress+Hauser
1042 = Promag 53
XXXXXXXXXXXX = device serial number (11-digit)
```

6.3.1 Commissioning

The following description allows step-by-step commissioning of the measuring device and all the necessary configuration for the FOUNDATION Fieldbus:

1. Switch on the measuring device.
2. Note the DEVICE_ID on the device nameplate → [6](#).
3. Open the configuration program.
4. Load the device description file or CFF file into the host system or into the configuration program. Ensure you use the correct system files. Refer to the example on → [64](#).
The first time it is connected Promag 53 reports as follows:

- E+H_PROMAG_53_XXXXXXXXXXXX (tag name PD-TAG)
- 452B481042-XXXXXXXXXXXX (Device_ID)
- Block structure:

Display text (xxx... = serial number)	Base index	Description
RESOURCE_XXXXXXXXXXXX	400	Resource Block
TRANSDUCER_FLOW_XXXXXXXXXXXX	1400	"Flow" Transducer Block
TRANSDUCER_DIAG_XXXXXXXXXXXX	1600	"Diagnosis" Transducer Block
TRANSDUCER_DISP_XXXXXXXXXXXX	1800	"Display" Transducer Block
TRANSDUCER_TOT_XXXXXXXXXXXX	1900	"Totalizer" Transducer Block
ANALOG_INPUT_1_XXXXXXXXXXXX	500	Analog Input function block 1
ANALOG_INPUT_2_XXXXXXXXXXXX	550	Analog Input function block 2
ANALOG_INPUT_3_XXXXXXXXXXXX	600	Analog Input function block 3
ANALOG_INPUT_4_XXXXXXXXXXXX	650	Analog Input function block 4
ANALOG_INPUT_5_XXXXXXXXXXXX	700	Analog Input function block 5
ANALOG_OUTPUT_XXXXXXXXXXXX	2300	Analog Output function block (AO)
DISCRETE_OUTPUT_XXXXXXXXXXXX	900	Discrete Output function block (DO)
PID_XXXXXXXXXXXX	1000	PID function block (PID)
ARITHMETIC_XXXXXXXXXXXX	1100	Arithmetic function block (ARTH)
INPUT_SELECTOR_XXXXXXXXXXXX	1150	Input Selector function block (ISEL)
SIGNAL_CHARACTER_XXXXXXXXXXXX	1200	Signal Characterizer function block (CHAR)
INTEGRATOR_XXXXXXXXXXXX	1250	Integrator function block (INTG)



Note!

The Promag 53 is supplied with the bus address "250" and is thus in the address range reserved for readdressing field devices, from 248 and 251. This means that the LAS (Link Active Scheduler) automatically assigns the device a free bus address in the initialization phase.

5. Identify the field device using the DEVICE_ID that you noted down and assign the desired field device tag name (PD_TAG) to the fieldbus device in question.
Factory setting: EH_PROMAG_53_XXXXXXXXXX

Configuration of the "Resource Block" (base index 400)

6. Open the Resource Block.
7. On delivery write protection is disabled so that you can access the write parameters via FF. Check this status via the parameter WRITE_LOCK:
 - Write protection activated = LOCKED
 - Write protection deactivated = NOT LOCKED

Deactivate the write protection if necessary → 66.

8. Enter the desired block name (optional).
Factory setting: RESOURCE_XXXXXXXXXX
9. Set the operating mode in the MODE_BLK parameter group (TARGET parameter) to AUTO.

Configuration of the "Transducer Blocks"

The individual Transducer Blocks comprise various parameter groups ordered by device-specific functions:

Transducer Block	Base index	Description
"Flow" Transducer Block	1400	Flow measurement
"Diagnosis" Transducer Block	1600	Diagnostic functions
"Display" Transducer Block	1800	Local display functions
"Totalizer" Transducer Block	1900	Totalizer 1 to 3

The following description provides an example for the "Flow" Transducer Block (base index: 1400).

10. Enter the desired block name (optional).
Factory setting: TRANSDUCER_FLOW_XXXXXXXXXX
11. Open the "Flow" Transducer Block.
12. Now configure the device-specific parameters relevant for your application.



Note!

- Changes to the device parameters can only be made after entering a valid access code in the "Access - Code" parameter.
- The selection of the system units in the "Flow" Transducer Block has no effect on the output value OUT (AI Block). Units of the process variables which are transmitted via the FF interface must be specified separately in the Analog Input function block via the XD_SCALE and OUT_SCALE parameter group.

13. Set the "Flow" and "Totalizer" Transducer Blocks to AUTO in the MODE_BLK parameter group (TARGET parameter). Only then is it ensured that the process variables can be processed correctly by the downstream AI function block.

Configuration of the "Analog Input function blocks"

The measuring device has five Analog Input function blocks that can be assigned to the various process variables. The following description provides an example for the Analog Input function block 1 (base index: 500).

14. Enter the desired name for the Analog Input function block (optional).
Factory setting: ANALOG_INPUT_1xxxxxxxxxxx
15. Open the Analog Input function block 1.
16. Set the operating mode in the MODE_BLK parameter group (TARGET parameter) to OOS, i.e. block Out Of Service.
17. Using the CHANNEL parameter select the process variable that is to be used as the input value for the function block algorithm (scaling and limit value monitoring functions).
The following settings are possible:

Process variable	Channel parameter
Mass flow	1
Volume flow	2
Totalizer 1	7
Totalizer 2	8
Totalizer 3	9

18. In the XD_SCALE parameter group, select the desired engineering unit and the block input range (e.g. measurement range of the flow application) for the process variable in question (see the example below).



Caution!

Make sure that the selected unit is suitable for the measurement variable of the selected process variable. Otherwise, the BLOCK_ERROR parameter will display the error message "Block Configuration Error", and the block operating mode cannot be set to AUTO.

19. In the L_TYPE parameter, select the mode of linearization for the input variable (Direct, Indirect, Indirect Sq Root) Æ "Description of Device Functions" manual



Caution!

Note that with the type of linearization "Direct" the configuration of the OUT_SCALE parameter group must agree with the configuration of the XD_SCALE parameter group. Otherwise the block operating mode cannot be set to AUTO. Such incorrect configuration is indicated in the BLOCK_ERROR parameter via the "Block Configuration Error" message.

Example:

- The measurement range of the sensor is 0 to 30 m³/h.
- The output range to the automation system should be 0 to 30 m³/h also.

The following settings should be made:

- Analog Input function block/CHANNEL parameter (selection of input value),
selection: 2 Æ Volume flow
- L_TYPE parameter Æ Direct
- XD_SCALE parameter group
XD_SCALE 0% = 0
XD_SCALE 100% = 30
XD_SCALE UNIT = m³/h
- OUT_SCALE parameter group
OUT_SCALE 0% = 0
OUT_SCALE 100% = 30
OUT_SCALE UNIT = m³/h

20. Use the following parameters to define the limit values for alarm and warning messages:
 - HI_HI_LIM → Limit value for the upper alarm
 - HI_LIM → Limit value for the upper warning
 - LO_LIM → Limit value for the lower warning
 - LO_LO_LIM → Limit value for the lower alarmThe limit values entered must be within the value range specified in the OUT_SCALE parameter group.
21. In addition to the actual limit values you must also specify the action taken if a limit value is exceeded using so-called "alarm priorities" (parameters HI_HI_PRI, HI_PRI, LO_PR, LO_LO_PRI) → See the "Description of Device Functions" manual. Reporting to the fieldbus host system only takes place if the alarm priority is higher than 2.
22. System configuration/connection of function blocks:

A concluding "overall system configuration" is essential so that the operating mode of the Analog Input function block can be set to AUTO and so that the field device is integrated into the system application. To do this, configuration software such as the NI-FBUS Configurator from National Instruments is used to connect the function blocks to the desired control strategy - generally graphically - and then the sequence of the individual process control functions is specified.
23. After specifying the active LAS, download all the data and parameters into the field device.
24. Set the operating mode in the MODE_BLK parameter group (TARGET parameter) to AUTO. However, this is possible only under two conditions:
 - The function blocks are correctly connected with each other.
 - The Resource Block is in operating mode AUTO.

6.3.2 "Commissioning" Quick Setup menu

If the measuring device is equipped with a local display, all device-specific parameters that are important for standard measuring operation can be configured easily and quickly using the "Commissioning" Quick Setup menu.

In the case of measuring devices without a local display, the individual parameters and functions must be configured via the configuration program, e.g. NI-FBUS Configurator.

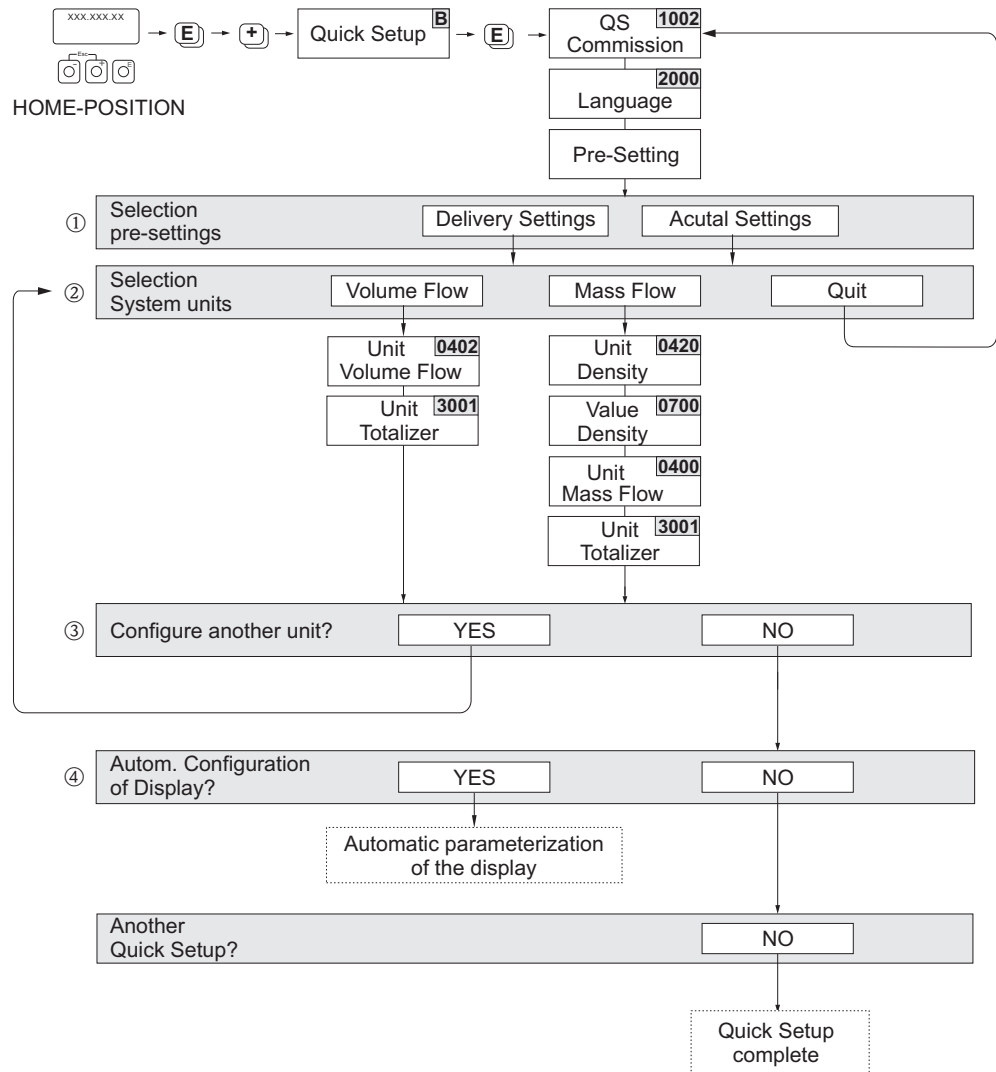

a0006395-en

Fig. 45: Quick Setup for straightforward commissioning

- ① The DELIVERY SETTINGS option sets each selected unit to the factory setting
The ACT.SETTING option accepts the units previously set by you.
- ② Only units not yet configured in the current setup are offered for selection in each cycle. The unit for Mass and Volume is derived from the corresponding flow unit.
- ③ The "YES" option remains visible until all the units have been configured.
"NO" is the only option displayed when no further units are available.
- ④ The "automatic parameterization of the display" option contains the following basic settings/factory settings:

YES	Main line = Volume flow
	Additional line = Totalizer 1
	Information line = Operating/System conditions
NO	The existing (selected) settings remain.



Note!

- The display returns to the SETUP COMMISSIONING (1002) cell if you press the key combination during parameter interrogation. The stored parameters remain valid.
- The system units selected via the Quick Setup are only valid for the local display and for parameters in the Transducer Blocks. You cannot influence the process variables which are transmitted via FOUNDATION Fieldbus.

6.3.3 Data backup/transmission

Using the T-DAT SAVE/LOAD function, you can transfer data (device parameters and settings) between the T-DAT (exchangeable memory) and the EEPROM (device storage unit).

This is required in the following instances:

- Creating a backup: current data are transferred from an EEPROM to the T-DAT.
- Replacing a transmitter: current data are copied from an EEPROM to the T-DAT and then transferred to the EEPROM of the new transmitter.
- Duplicating data: current data are copied from an EEPROM to the T-DAT and then transferred to EEPROMs of identical measuring points.



Note!

For information on installing and removing the T-DAT → 91.

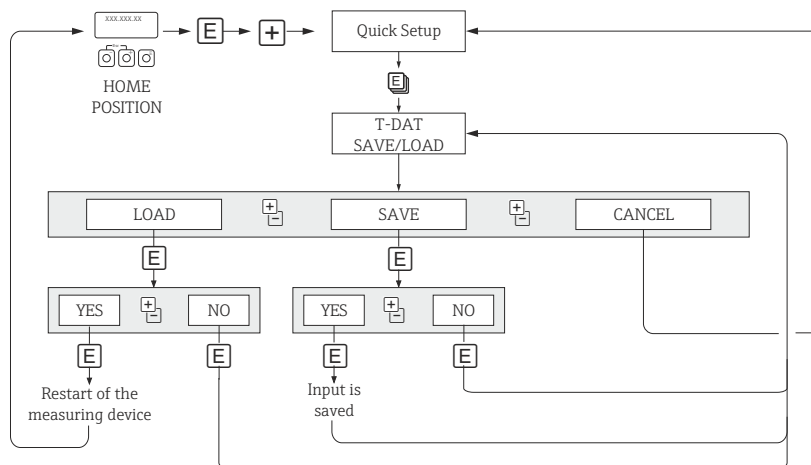

a0001221-en

Fig. 46: Data backup/transmission with T-DAT SAVE/LOAD function

Information on the LOAD and SAVE options available:

LOAD: Data are transferred from the T-DAT to the EEPROM.



Note!

- Any settings already saved on the EEPROM are deleted.
- This option is only available if the T-DAT contains valid data.
- This option can be performed only if the T-DAT is using either the same software version as the EEPROM or a newer version. Otherwise, the error message "TRANSM. SW-DAT" appears after a restart, and the LOAD function is then no longer available.

SAVE:

Data are transferred from the EEPROM to the T-DAT

6.4 Adjustment

6.4.1 Empty pipe/full pipe adjustment

Flow cannot be measured correctly unless the measuring tube is full. This state can be permanently monitored by means of empty pipe detection (EPD).



Caution!

A detailed description and other helpful hints for the empty pipe/full pipe adjustment procedure can be found in the separate "Description of Device Functions" manual:

- EPD ADJUSTMENT (6480) → Carrying out the adjustment.
- EMPTY PIPE DET. (6420) → Switching EPD on and off
- EPD RESPONSE TIME (6425) → Input of the response time for EPD



Note!

- The EPD function is not available unless the sensor is fitted with an EPD electrode.
- The devices are already calibrated at the factory using water (approx. 500 µS/cm). If the fluid conductivity differs from this reference, empty pipe/full pipe adjustment must be performed again on site.
- The default setting for the EPD function when the devices are delivered is OFF; the function must be activated if required.
- The EPD process error can be output by means of the configurable relay outputs.

Performing empty pipe and full pipe adjustment (EPD)

1. Select the appropriate function in the function matrix:
HOME → → → BASIC FUNCTIONS → → → PROCESSPARAMETER → → → ADJUSTMENT → → EPD ADJUSTMENT
2. Empty the piping. For EPD empty pipe adjustment, the wall of the measuring tube should be wetted with fluid.
3. Start empty pipe adjustment: Select "EMPTY PIPE ADJUST" and confirm by pressing .
4. After empty pipe adjustment, fill the piping with fluid.
5. Start full pipe adjustment: Select "FULL PIPE ADJUST" and confirm by pressing .
6. Having completed the full pipe adjustment, select the "OFF" setting and exit the function by pressing .
7. Now select the EMPTY PIPE DET. function (6420). Switch on the empty pipe detection by selecting "ON STANDARD" and confirm by pressing .





Caution!

The adjustment coefficients must be valid before you can activate the EPD function. If adjustment is incorrect, the following messages might appear on the display:

- ADJUSTMENT FULL = EMPTY
The calibration values for empty pipe and full pipe are identical. In such cases you must repeat empty pipe or full pipe adjustment.
- ADJUSTMENT NOT OK
Adjustment is not possible because the fluid's conductivity is out of range.

Performing empty pipe/full pipe adjustment (with configuration program )

1. Make sure that hardware write protection is switched off →  66.
2. In the configuration program, open the "Flow" Transducer Block (TRANSDUCER_FLOW_XXXXXXXXXX/base index: 1400).
3. Enable programming:
 - Enter the access code in the "Access – Code" parameter.
 - In the "Access – Status" parameter, the message "ACCESS CUSTOMER" should now appear.
4. Empty the piping. For the following empty pipe adjustment, the wall of the measuring tube should be wetted with fluid.
5. Start empty pipe adjustment:
 - In the "EPD – Adjustment" parameter, select the "Empty Pipe Adjust" setting.
 - Start the empty pipe adjustment by sending this setting to the field device.
6. After empty pipe adjustment, fill the piping with fluid.
7. Start full pipe adjustment when the medium is stagnant:
 - In the "EPD – Adjustment" parameter, select the "Full Pipe Adjust" setting.
 - Now start the full pipe adjustment by sending this setting to the field device.
8. On completion of the adjustment, select the setting "Off" and exit the function by sending this setting to the field device.
9. Now select the "EPD – Empty Pipe Detection" parameter. Switch on empty pipe detection by selecting the setting "ON (for EPD)" and sending the setting to the field device.

 **Caution!**

The adjustment values must be valid before you can activate the EPD function. If the adjustment is incorrect, the following messages are output in the "Diagnosis" Transducer Block (base index: 1600) by means of the "Diag. – Act.Sys.Condition" parameter:

- EPD adjustment wrong – Err. No. 463

The adjustment values for empty pipe and full pipe are identical. In such cases you must repeat empty pipe or full pipe adjustment.

This error (→  89) is conveyed to the downstream function blocks by means of the "BAD" status of the AI Block output variable OUT.

- EPD adjustment not possible – Err. No. 461

Adjustment is not possible as the conductivity of the medium is outside the permitted range.

This error (→  89) is conveyed to the downstream function blocks by means of the "UNCERTAIN" status of the AI Block output variable OUT.

6.5 Data storage devices

At Endress+Hauser, the term HistoROM refers to various types of data storage modules on which process and measuring device data are stored. By plugging and unplugging such modules, device configurations can be duplicated onto other measuring devices to cite just one example.

6.5.1 HistoROM/S-DAT (sensor DAT)

The S-DAT is an exchangeable data storage device in which all sensor data are stored, i.e., nominal diameter, serial number, calibration factor, zero point.

6.5.2 HistoROM/T-DAT (transmitter DAT)

The T-DAT is an exchangeable data storage device in which all transmitter parameters and settings are stored.

Storing of specific parameter settings from the device memory (EEPROM) to the T-DAT module and vice versa must be carried out by the user (= manual save function). Detailed instructions regarding this can be found on →  73.

6.5.3 F-CHIP (function chip)

The F-CHIP is a microprocessor component which contains additional software packages which are used to enhance the functionality and therefore the range of application of the transmitter.

If an upgrade is carried out at a later stage, the F-CHIP can be ordered as an accessory and can simply be inserted into the I/O board. After startup, the transmitter can access this software immediately.

Accessories →  78

Inserting into the I/O board →  91



Caution!

To avoid any confusion, once the F-CHIP has been put on the I/O board, it is labeled with the transmitter's serial number i.e. the F-CHIP can then no longer be used for another measuring device.

7 Maintenance

No special maintenance work is required.

7.1 Exterior cleaning

When cleaning the exterior of measuring devices, always use cleaning agents that do not attack the surface of the housing or the seals.

7.2 Seals

The seals in the Promag H sensor should be replaced periodically, particularly when molded seals (aseptic version) are used!

The interval between replacements depends on the frequency of the cleaning cycles and on the temperature of the fluid and of the cleaning process.

Replacement seals (accessory) →  78.

8 Accessories

Various accessories, which can be ordered separately from Endress+Hauser, are available for the transmitter and the sensor. Your Endress+Hauser service organization can provide detailed information on the order code of your choice.

8.1 Device-specific accessories

Accessory	Description	Order code
Transmitter Promag 53 FOUNDATION Fieldbus	Transmitter for replacement or for stock. Use the order code to define the following specifications: <ul style="list-style-type: none"> - Approvals - Degree of protection / version - Cable type for remote version - Cable entries - Display / power supply / operation - Software - Outputs / inputs 	53XXX - XXXXX * * * * * * * *
Software packages for Promag 53 FOUNDATION Fieldbus	Additional software on F-Chip can be ordered individually: <ul style="list-style-type: none"> - ECC electrode cleaning 	DK5SO-X
Conversion kit for outputs/inputs	Conversion kit with appropriate plug-in point modules to change the current input/output configuration to a new version.	DKUI-*

8.2 Accessories specific to measuring principle

Accessory	Description	Order code
Mounting kit for Promag 53 transmitter	Mounting kit for wall-mount housing (remote version). Suitable for: <ul style="list-style-type: none"> ■ Wall mounting ■ Pipe mounting ■ Panel mounting Mounting set for aluminum field housing. Suitable for: <ul style="list-style-type: none"> ■ Pipe mounting 	DK5WM - *
Cable for remote version	Coil and signal cables, various lengths. Reinforced cable on request.	DK5CA - **
Ground cable for Promag E/P/W	A set consists of two ground cables.	DK5GC - ***
Ground disk for Promag E/P/W	Ground disk for potential equalization.	DK5GD - * * * * *
Mounting kit for Promag H	Mounting kit for Promag H, consisting of: <ul style="list-style-type: none"> ■ 2 Process connections ■ Screws ■ Seals 	DKH ** - * * * * *
Adapter connection for Promag A/H	Adapter connections for installation of Promag 53 H instead of Promag 30/33 A or Promag 30/33 H/DN 25.	DK5HA - * * * * * * *
Grounding rings for Promag H	Grounding rings for potential equalization.	DK5HR - ***
Seal set for Promag H	For regular replacement of seals in the Promag H sensor.	DK5HS - ***
Wall mounting kit Promag H	Wall mounting kit for Promag H transmitter.	DK5HM - **
Welding jig for Promag H	Weld nipple as process connection: Welding jig for installation in piping.	DK5HW - ***

8.3 Communication-specific accessories

Accessory	Description	Order code
Handheld terminal DXR375	Handheld terminal for remote parameterization and for fetching measured values via the FOUNDATION Fieldbus H1. Contact your Endress+Hauser representative for more information.	DXR375 - * * * * *

8.4 Service-specific accessories

Accessory	Description	Order code
Applicator	Software for selecting and configuring flowmeters. Applicator can be downloaded from the Internet or ordered on CD-ROM for installation on a local PC. Contact your Endress+Hauser representative for more information.	DXA80 - *
Fieldcheck	Tester/simulator for testing flowmeters in the field. When used in conjunction with the "FieldCare" software package, test results can be imported into a database, printed and used for official certification. Contact your Endress+Hauser representative for more information.	50098801
FieldCare	FieldCare is Endress+Hauser's FDT-based plant asset management tool. It can configure all intelligent field devices in your plant and supports you in the administration of these devices. Through the use of status information, it is also an easy but effective means of monitoring the status of these devices.	See product list on the Endress+Hauser website: www.endress.com
FXA193	Service interface of device to the PC for operation via FieldCare.	FXA193 - *
Memograph M graphic display recorder	The Memograph M graphic display recorder provides information on all relevant process variables: Measuring values are recorded reliably, limit values monitored and measuring points analyzed. The data are stored in the 256 MB internal memory and also on an SD card or USB stick. The PC software package ReadWin® 2000, which is supplied as standard, is used for configuration, visualization and storage of the recorded data.	RSG40-*****

9 Troubleshooting

9.1 Troubleshooting instructions

If faults occur after commissioning or during operation, always start troubleshooting with the checklist below. The routine takes you directly to the cause of the problem and the appropriate remedial measures.



Caution!

In the event of a serious fault, a flowmeter might have to be returned to the manufacturer for repair. The necessary procedures must be carried out before you return the device to Endress+Hauser → 5.

Always enclose a duly completed "Declaration of Contamination" form. You will find a preprinted blank of this form at the back of this manual.



Check the display	
No display visible. No connection to the FF host system	<ol style="list-style-type: none"> 1. Check the supply voltage → Terminals 1, 2 2. Check device fuse → 96 85 to 260 V AC: 0.8 A slow-blow / 250 V 20 to 55 V AC and 16 to 62 V DC: 2 A slow-blow / 250 V 3. Measuring electronics defective → Order spare part → 91
No display visible. Connection to the FF host system established however.	<ol style="list-style-type: none"> 1. Check whether the ribbon-cable connector of the display module is correctly plugged into the amplifier board → 91 2. Display module defective → Order spare part → 91 3. Measuring electronics defective → Order spare part → 91
Display texts are in a foreign language.	Switch off power supply. Then press the keys simultaneously to switch the device back on. The display text will appear in English (default) and is displayed at maximum contrast.
No connection can be established with the FF host system, even though measured value reading is visible.	Measuring electronics board defective → Order spare part → 91



Error messages on display	
Errors which occur during commissioning or operation are displayed immediately. Error messages consist of a variety of icons. The meanings of these icons are as follows (example): <ul style="list-style-type: none"> - Error type: S = system error, P = process error - Error message type: = fault message, ! = notice message - EMPTY PIPE = type of error, e.g. measuring tube is only partly filled or completely empty - 03:00:05 = duration of error occurrence (in hours, minutes and seconds) - #401 = error number 	
Caution! <ul style="list-style-type: none"> ■ Also observe the information on → 63 ■ The measuring system interprets simulations and positive zero return as system errors, but displays them only as a notice message. 	
Error number: No. 001 - 399 No. 501 - 699	System error (device error) has occurred → 84
Error number: No. 401 - 499	Process error (application error) has occurred → 90











Faulty connection to the fieldbus host system	
No connection can be made between the fieldbus host system and the measuring device. Check the following points:	
Supply voltage Transmitter	Check the supply voltage → Terminals 1/2

Device fuse	Check device fuse →  96 85 to 260 V AC: 0.8 A slow-blow / 250 V 20 to 55 V AC and 16 to 62 V DC: 2 A slow-blow / 250 V
Fieldbus connection	FOUNDATION Fieldbus: check the data cable Terminal 26 = FF + Terminal 27 = FF –
Fieldbus connector (Option)	<ul style="list-style-type: none"> ▪ Check pin assignment/wiring →  51 ▪ Check connection between connector/fieldbus port. Is the coupling ring tightened correctly?
Fieldbus voltage	Check that a min. bus voltage of 9 V DC is present at terminals 26/27. Permissible range: 9 to 32 V DC
Network structure	Check permissible fieldbus length and number of spurs →  42.
Basic current	Is there a basic current of min. 12 mA?
Bus address	Check bus address: make sure there are no double assignments
Bus termination (Termination)	Is the FOUNDATION Fieldbus H1 correctly terminated? Each bus segment must always be terminated with a bus terminator at both ends (start and finish). Otherwise there may be interference during data transmission.
Current consumption, permitted feed current	Check the current consumption of the bus segment: The current consumption of the bus segment in question (= total of basic currents of all bus users) must not exceed the max. permissible feed current of the bus power supply.
Device Description (DD)	<p>Install the DD if you cannot access the manufacturer-specific parameters.</p> <p> Note! Ensure you use the correct system files for linking the field devices into the host system. Appropriate version information can be called up in the measuring device via the following functions/parameters:</p> <p>Local display:</p> <ul style="list-style-type: none"> ▪ HOME → BASIC FUNCTION → FOUND. FIELDBUS → INFORMATION → DEVICE REVISION (6243) ▪ HOME → BASIC FUNCTION → FOUND. FIELDBUS → INFORMATION → DD REVISION (6244) <p>FF configuration program:</p> <ul style="list-style-type: none"> ▪ Resource Block → Parameter DEV_REV ▪ Resource Block → Parameter DD_REV <p>Example (with local display): Displayed in the DEVICE REVISION (6243) function → 04 Displayed in the DD REVISION (6244) function → 01 Device description file (DD) required → 0401.sym / 0401.ffa</p>



Problems with configuration of function blocks	
Transducer Blocks: The operating mode cannot be set to AUTO.	Check whether the operating mode of the Resource Block is in AUTO mode → MODE_BLK parameter group / TARGET parameter.

<p>Analog Input function block: The operating mode cannot be set to AUTO.</p>	<p>There may be several reasons for this. Check the following in sequence:</p> <ol style="list-style-type: none"> 1. Check whether the operating mode of the Analog Input function block is in AUTO mode → MODE_BLK parameter group / TARGET parameter. If not and the mode cannot be set to AUTO, first check the following. 2. Please ensure that the CHANNEL parameter (process variable option) is already configured in the Analog Input function block → 91. The option CHANNEL = 0 (uninitialized) is not valid. 3. Make sure that the XD_SCALE parameter group (input range, unit) is already configured in the Analog Input function block → 91 (incl. configuration example) <ul style="list-style-type: none">  Caution! Make sure that the selected unit is suitable for the process variable selected in the CHANNEL parameter. Otherwise the BLOCK_ERROR parameter will display the error message "Block Configuration Error". In this status the block operating mode cannot be set to AUTO. 4. Make sure that the L_TYPE parameter (type of linearization) is already configured in the Analog Input function block → 91. <ul style="list-style-type: none">  Caution! Make sure that with in the case of the "Direct" type of linearization, the scaling of the OUT_SCALE parameter group is identical to that of the XD_SCALE parameter group. If set incorrectly, the BLOCK_ERROR parameter will display the error message "Block Configuration Error". In this status, the operating mode cannot be set to AUTO. Configuration example → 91 5. Check whether the operating mode of the Resource Block is set to AUTO → MODE_BLK parameter group / TARGET parameter. 6. Make sure that the function blocks are correctly interconnected and that this system configuration has been sent to the fieldbus users → 91.
<p>Analog Input function block: The operating mode is set to AUTO, but the status of the AI output value OUT is "BAD" or "UNCERTAIN".</p>	<ol style="list-style-type: none"> 1. Check whether the operating mode of the Transducer Blocks is set to AUTO → MODE_BLK parameter group / TARGET parameter. Use the different CHANNEL parameters to set the Transducer Blocks (→ 100) to AUTO. 2. Check if there is a fault in the "Diagnosis" Transducer Block (base index: 1600) → "Diagnosis" Transducer Block (base index: 1600) → "Diag. - Act.Sys.Condition" parameter. <p>Error messages → 84</p>
<p>Parameters cannot be modified, or no write access to parameters.</p>	<ol style="list-style-type: none"> 1. Parameters that display only values or settings cannot be modified! 2. Hardware write protection is enabled → Disable write protection → 91 <ul style="list-style-type: none">  Note! You can use the WRITE_LOCK parameter in the Resource Block to check whether hardware write protection is enabled or disabled: LOCKED = write protection activated (enabled) UNLOCKED = no write protection (disabled) 3. The block operating mode is wrong. Certain parameters can only be modified in OOS (Out of Service) or MAN (MANual) mode → Set the operating mode of the block to the required mode → MODE_BLK parameter group. 4. The value entered is outside the specified input range for the parameter in question: <ul style="list-style-type: none"> → Enter suitable value → Increase input range if necessary 5. Transducer Blocks: The programming level is not enabled → Enable by entering the code in the "Access - Code" parameter or by means of the service code in the service parameters.

<p>Transducer Block: The manufacturer-specific parameters are not visible.</p>	<p>The device description file (Device Description, DD) has not yet been loaded into the host system or the configuration program → Download the file into the configuration system.</p> <p>Reference sources of the DD →  91</p> <p> Note! Ensure you use the correct system files for linking the field devices into the host system. Appropriate version information can be called up in the measuring device via the following functions/parameters:</p> <p>Local display:</p> <ul style="list-style-type: none"> ■ HOME → BASIC FUNCTION → FOUND. FIELDBUS → INFORMATION → DEVICE REVISION (6243) ■ HOME → BASIC FUNCTION → FOUND. FIELDBUS → INFORMATION → DD REVISION (6244) <p>FF configuration program:</p> <ul style="list-style-type: none"> ■ Resource Block → Parameter DEV_REV ■ Resource Block → Parameter DD_REV <p>Example (with local display): Displayed in the DEVICE REVISION (6243) function → 04 Displayed in the DD REVISION (6244) function → 01 Required device description file (DD) → 0401.sym / 0401.ffa</p>
<p>Analog Input function block: The output value OUT is not updated despite having a valid "GOOD" status.</p>	<p>Simulation is active → Deactivate simulation via SIMULATE parameter group.</p>
<p>Error messages</p>	
<p>Error messages in the FF configuration program →  84 Error messages on the local display →  84</p>	
<p>▼</p>	
<p>Other errors (without error message)</p>	
<p>Some other errors have occurred.</p>	<p>Diagnosis and rectification →  99</p>

9.2 System/process error messages

General notes

The device assigns current system and process errors to two error message types, with the result that they are evaluated differently:

"Fault message" error message type:

- A message of this type immediately interrupts or stops measurement.
- Presentation on the FOUNDATION Fieldbus → Fault messages are transmitted to downstream function blocks or higher-level process control systems using the "BAD" status of the AI output parameter OUT.
- Local display → A flashing lightning symbol (⚡) is displayed

"Notice message" error message type:

- Measurement continues despite this message.
- Presentation on the FOUNDATION Fieldbus → Notice messages are transmitted to downstream function blocks or higher-level process control systems using the "UNCERTAIN" status of the AI output parameter OUT.
- Local display → A flashing exclamation mark (!) is displayed.

Critical system errors, e.g. module defects, are always identified and displayed as "fault messages" by the measuring device. Simulations in the "Flow" Transducer Block and positive zero return, on the other hand, are identified by the measuring system as "notice messages" only.

Error messages in the FF configuration programs → See Table

System and process errors are recognized and reported in the Transducer Blocks. Such errors are displayed via the following parameters defined in the FOUNDATION Fieldbus specification:

- BLOCK_ERR
- Transducer Error

In the "Diagnosis" Transducer Block (base index: 1600), detailed causes of errors and device status messages are displayed by means of the "Diag. - Act.Sys.Condition" parameter (manufacturer-specific) → Table.

Error messages on the local display → See table



You will find more details on how error messages are presented on →  63.

9.2.1 List of system error messages

No.	Error messages: FOUNDATION Fieldbus (FF)* (local display)	Transducer Block error messages	Analog Input function block error messages	Cause/remedy
* With FF, error messages are displayed in the "Diagnosis" Transducer Block (base index: 1600) by means of the "Diag. - Act.Sys.Condition" parameter (manufacturer-specific). S = System error ⚡ = Fault message (with an effect on operation) ! = Notice message (without an effect on operation)				
No. # 0xx → Hardware error				
001	<i>Device status message (FF):</i> ROM/RAM failure – Err. No. 001 <i>Local display:</i> S: CRITICAL FAIL. ⚡: # 001	BLOCK_ERR = Device needs maintenance now	OUT. QUALITY = BAD	<i>Cause:</i> ROM/RAM error. Error when accessing the program memory (ROM) or random access memory (RAM) of the processor. <i>Remedy:</i> Replace the amplifier board. Spare parts → 91
		Transducer_Error = Electronics failure	OUT. SUBSTATUS = Device Failure	
			BLOCK_ERR = Input Failure (faulty input value from Transducer Blocks)	
011	<i>Device status message (FF):</i> Amplifier EEPROM failure – Err. No. 011 <i>Local display:</i> S: AMP HW EEPROM ⚡: # 011	BLOCK_ERR = Device needs maintenance now	OUT. QUALITY = BAD	<i>Cause:</i> Amplifier with faulty EEPROM <i>Remedy:</i> Replace the amplifier board. Spare parts → 91
		Transducer_Error = Data integrity error	OUT. SUBSTATUS = Device Failure	
			BLOCK_ERR = Input Failure (faulty input value from Transducer Blocks)	
012	<i>Device status message (FF):</i> Amplifier EEPROM data inconsistent – Err. No. 012 <i>Local display:</i> S: AMP SW EEPROM ⚡: # 012	BLOCK_ERR = Device needs maintenance now	OUT. QUALITY = BAD	<i>Cause:</i> Error when accessing data of EEPROM measuring amplifier <i>Remedy:</i> Perform a "warm restart" (i.e. restart the measuring system without disconnecting mains power). ■ FF: "Diagnosis" Transducer Block (base index: 1600) → "Sys. – Reset" RESTART SYSTEM parameter ■ Local display: SUPERVISION → SYSTEM → OPERATION → SYSTEM RESET (→ RESTART SYSTEM)
		Transducer_Error = Data integrity error	OUT. SUBSTATUS = Device Failure	
			BLOCK_ERR = Input Failure (faulty input value from Transducer Blocks)	
031	<i>Device status message (FF):</i> S-DAT failure / S-DAT not inserted – Err. No. 031 <i>Local display:</i> S: SENSOR HW DAT ⚡: # 031	BLOCK_ERR = Device needs maintenance now	OUT. QUALITY = BAD	<i>Cause:</i> 1. S-DAT is not correctly plugged into the amplifier board (or is missing). 2. S-DAT is defective. <i>Remedy:</i> 1. Check whether the S-DAT is correctly plugged into the amplifier board, 2. Replace the S-DAT if it is defective. Spare parts → 91 Check whether the new replacement DAT is compatible with the existing electronics. Check the: - Spare part set number - Hardware revision code 3. Replace measuring electronics boards if necessary Spare parts → 91 4. Plug the S-DAT into the amplifier board.
		Transducer_Error = Electronics failure	OUT. SUBSTATUS = Device Failure	
			BLOCK_ERR = Input Failure (faulty input value from Transducer Blocks)	
032	<i>Device status message (FF):</i> S-DAT data inconsistent – Err. No. 032 <i>Local display:</i> S: SENSOR SW DAT ⚡: # 032	BLOCK_ERR = Device needs maintenance now	OUT. QUALITY = BAD	(Continued from previous row)
		Transducer_Error = Data integrity error	OUT. SUBSTATUS = Device Failure	
			BLOCK_ERR = Input Failure (faulty input value from Transducer Blocks)	

No.	Error messages: FOUNDATION Fieldbus (FF)* (local display)	Transducer Block error messages	Analog Input function block error messages	Cause/remedy
041	<i>Device status message (FF):</i> T-DAT failure – Err. No. 041 <i>Local display:</i> S: TRANSM. HW-DAT !/: # 041	BLOCK_ERR = Device needs maintenance now	OUT. QUALITY = BAD	<i>Cause:</i> 1. T-DAT is not correctly plugged into the amplifier board (or is missing). 2. T-DAT is defective. <i>Remedy:</i> 1. Check whether the T-DAT is correctly plugged into the amplifier board. 2. Replace the T-DAT if it is defective. Spare parts → 91 Check whether the new replacement DAT is compatible with the existing electronics. Check the: - Spare part set number - Hardware revision code 3. Replace measuring electronics boards if necessary Spare parts → 92 4. Plug the T-DAT into the amplifier board.
		Transducer_Error = Electronics failure	OUT. SUBSTATUS = Device Failure	
			BLOCK_ERR = Input Failure (faulty input value from Transducer Blocks)	
042	<i>Device status message (FF):</i> T-DAT data inconsistent – Err. No. 042 <i>Local display:</i> S: TRANSM. SW-DAT !/: # 042	BLOCK_ERR = Device needs maintenance now	OUT. QUALITY = BAD	2. Replace the T-DAT if it is defective. Spare parts → 91 Check whether the new replacement DAT is compatible with the existing electronics. Check the: - Spare part set number - Hardware revision code 3. Replace measuring electronics boards if necessary Spare parts → 92 4. Plug the T-DAT into the amplifier board.
		Transducer_Error = Data integrity error	OUT. SUBSTATUS = Device Failure	
			BLOCK_ERR = Input Failure (faulty input value from Transducer Blocks)	
No. # 1xx → Software error				
101	<i>Device status message (FF):</i> GAIN ERROR AMPLIFIER – Err. No. 101 <i>Local display:</i> S: GAIN ERROR AMP. !/: # 101	BLOCK_ERR = Device needs maintenance now	OUT. QUALITY = BAD	<i>Cause:</i> Gain deviation compared to reference gain is greater than 2%. <i>Remedy:</i> Replace the amplifier board → 92
		Transducer_Error = Electronics failure	OUT. SUBSTATUS = Device Failure	
			BLOCK_ERR = Input Failure (faulty input value from Transducer Blocks)	
121	<i>Device status message (FF):</i> Software compatibility problem amplifier – I/O module – Err. No. 121 <i>Local display:</i> S: A/C COMPATIB. !/: # 121	BLOCK_ERR = Device needs maintenance now	OUT. QUALITY = BAD	<i>Cause:</i> Due to different software versions, I/O board and amplifier board are only partially compatible (possibly restricted functionality). 📝 Note! – Appears on the display as a notice message for only 30 seconds (with listing in "Previous system condition" function). – This occurrence of different software versions can occur if only one electronics board has been replaced; the extended software functionality is not available. The previously existing software functionality is still working and the measurement possible. <i>Remedy:</i> Module with lower software version must either be updated by "FieldCare" using the required (recommended) software version, or the module must be replaced → 92.
		Transducer_Error = I/O failure (input/output error)	OUT. SUBSTATUS = Device Failure	
			BLOCK_ERR = Input Failure (faulty input value from Transducer Blocks)	
No. # 2xx → Error in DAT / no communication				





No.	Error messages: FOUNDATION Fieldbus (FF)* (local display)	Transducer Block error messages	Analog Input function block error messages	Cause/remedy
205	<i>Device status message (FF):</i> Save to T-DAT failed – Err. No. 205 <i>Local display:</i> S: LOAD T-DAT !: # 205	BLOCK_ERR = Device needs maintenance now	OUT. QUALITY = BAD	<i>Cause:</i> Data backup (downloading) to T-DAT failed, or error when accessing (uploading) the calibration values stored in the T-DAT. <i>Remedy:</i> 1. Check whether the T-DAT is correctly plugged into the amplifier board. 2. Replace the T-DAT if it is defective → 92 Before replacing the DAT, check that the new, replacement DAT is compatible with the existing electronics. Check the: – Spare part set number – Hardware revision code 3. Replace measuring electronics boards if necessary → 92
		Transducer_Error = Electronics failure	OUT. SUBSTATUS = Device Failure	
			BLOCK_ERR = Input Failure (faulty input value from Transducer Blocks)	
206	<i>Device status message (FF):</i> Restore from T-DAT failed – Err. No. 206 <i>Local display:</i> S: SAVE T-DAT !: # 206	BLOCK_ERR = Device needs maintenance now	OUT. QUALITY = BAD	
		Transducer_Error = Electronics failure	OUT. SUBSTATUS = Device Failure	
			BLOCK_ERR = Input Failure (faulty input value from Transducer Blocks)	
261	<i>Device status message (FF):</i> Communication failure I/O – Err. No. 261 <i>Local display:</i> S: COMMUNICAT. I/O !: # 261	BLOCK_ERR = Device needs maintenance now	OUT. QUALITY = BAD	<i>Cause:</i> Communication error. No communication between amplifier and I/O board or faulty internal data transfer. <i>Remedy:</i> Check whether the electronics boards are correctly inserted in their holders → 92
		Transducer_Error = I/O failure (communication problems)	OUT. SUBSTATUS = Device Failure	
			BLOCK_ERR = Input Failure (faulty input value from Transducer Blocks)	
No. # 3xx → System limits exceeded				
321	<i>Device status message (FF):</i> Coil current out of tolerance – Err. No. 321 <i>Local display:</i> S: TOL. COIL CURR. !: # 321	BLOCK_ERR = Device needs maintenance now	OUT. QUALITY = BAD	<i>Cause:</i> The coil current of the sensor is out of tolerance. <i>Remedy:</i>  Warning! Switch off power supply before manipulating the coil current cable, coil current cable connector or measuring electronics boards! Remote version: 1. Check wiring of terminals 41/42 → 44 2. Check coil current cable connector. Compact and remote version: Replace measuring electronics boards if necessary → 92
		Transducer_Error = Mechanical failure	OUT. SUBSTATUS = Device Failure	
			BLOCK_ERR = Input Failure (faulty input value from Transducer Blocks)	
No. # 5xx → Application error				
501	<i>Device status message (FF):</i> Download device software active – Err. No. 501 <i>Local display:</i> S: SW.-UPDATE ACT. !: # 501	BLOCK_ERR = Device needs maintenance now	OUT. QUALITY = UNCERTAIN	<i>Cause:</i> New amplifier or communication software version is loaded into device. Currently no other functions are possible. <i>Remedy:</i> Wait until the procedure is finished. The device will restart automatically.
		Transducer_Error = General Error	OUT. SUBSTATUS = Device Failure	
			BLOCK_ERR = Input Failure (faulty input value from Transducer Blocks)	
502	<i>Device status message (FF):</i> Up-/download device software active – Err. No. 502 <i>Local display:</i> S: UP-/DOWNLO. ACT. !: # 502	BLOCK_ERR = Device needs maintenance now	OUT. QUALITY = UNCERTAIN	<i>Cause:</i> Uploading or downloading the device data via operating program. Currently no other functions are possible. <i>Remedy:</i> Wait until the procedure is finished.
		Transducer_Error = General Error	OUT. SUBSTATUS = Device Failure	
			BLOCK_ERR = Input Failure (faulty input value from Transducer Blocks)	

No.	Error messages: FOUNDATION Fieldbus (FF)* (local display)	Transducer Block error messages	Analog Input function block error messages	Cause/remedy
No. # 6xx → Simulation mode active				
601	<i>Device status message (FF):</i> Positive zero return active – Err. No. 601 <i>Local display:</i> S: POS. ZERO-RETURN !: # 601		OUT. QUALITY = UNCERTAIN OUT. SUBSTATUS = Nonspecific	<i>Cause:</i> Positive zero return is active.  Note! This notice message has the highest display priority! <i>Remedy:</i> Deactivate positive zero return: <ul style="list-style-type: none"> ■ FF: "Flow" Transducer Block (base index: 1100) → "System - Positive Zero Return" parameter → OFF ■ Local display: BASIC FUNCTIONS → SYSTEM PARAMETERS → CONFIGURATIONS → POS. ZERO RETURN (→ OFF)
691	<i>Device status message (FF):</i> Simulation failsafe active – Err. No. 691 <i>Local display:</i> S: SIM. FAILSAFE !: # 691	BLOCK_ERR = Simulation active	OUT. QUALITY = UNCERTAIN OUT. SUBSTATUS = Nonspecific BLOCK_ERR = Simulation active	<i>Cause:</i> Simulation of failsafe mode (outputs) is active. <i>Remedy:</i> Switch off simulation: <ul style="list-style-type: none"> ■ FF: "Diagnosis" Transducer Block (base index: 1600) → "Sys. – Sim.Failsafe Mode" parameter → OFF ■ Local display: SUPERVISION → SYSTEM → OPERATION → SIM. FAILSAFE MODE (→ OFF)
692	<i>Device status message (FF):</i> Simulation volume flow active – Err. No. 692 <i>Local display:</i> S: SIM. MEASURAND !: # 692	BLOCK_ERR = Simulation active	OUT. QUALITY = UNCERTAIN OUT. SUBSTATUS = Nonspecific BLOCK_ERR = Simulation active	<i>Cause:</i> Simulation of the measured value is active. <i>Remedy:</i> Switch off simulation: <ul style="list-style-type: none"> ■ FF: "Flow" Transducer Block (base index: 1400) → "Simulation - Measurand" parameter → OFF ■ Local display: SUPERVISION → SYSTEM → OPERATION → SIM. MEASURAND (→ OFF)
–	No communication to amplifier	BLOCK_ERR = Device needs maintenance now Transducer_Error = General Error	OUT. QUALITY = BAD OUT. SUBSTATUS = Device Failure BLOCK_ERR = Input Failure (faulty input value from Transducer Blocks)	<i>Cause:</i> Communication error. No communication with measuring amplifier. <i>Remedy:</i> <ol style="list-style-type: none"> 1. Switch power supply off and on again. 2. Check whether the electronics boards are correctly inserted in their holders →  92

9.2.2 List of process error messages

No.	Error messages: FOUNDATION Fieldbus (FF)* (local display)	Transducer Block error messages	Analog Input function block error messages	Cause/remedy
<p>* With FF, error messages are displayed in the "Diagnosis" Transducer Block (base index: 1600) by means of the "Diag. - Act.Sys.Condition" parameter (manufacturer-specific).</p> <p>P = Process error ⚡ = Fault message (with an effect on operation) ! = Notice message (without an effect on operation)</p>				
401	<p><i>Device status message (FF):</i> Empty pipe detected – Err. No. 401</p> <p><i>Local display:</i> P: EMPTY PIPE ⚡: # 401</p>		<p>OUT. QUALITY = UNCERTAIN</p> <p>OUT. SUBSTATUS = Nonspecific</p>	<p><i>Cause:</i> Measuring tube partially filled or empty.</p> <p><i>Remedy:</i> 1. Check the process conditions of the plant. 2. Fill the measuring tube.</p>
461	<p><i>Device status message (FF):</i> EPD adjustment not possible – Err. No. 461</p> <p><i>Local display:</i> P: ADJ. NOT OK !: # 461</p>	<p>Transducer_Error = Configuration error</p>	<p>OUT. QUALITY = UNCERTAIN</p> <p>OUT. SUBSTATUS = Non specific</p>	<p><i>Cause:</i> EPD adjustment not possible because the fluid's conductivity is either too low or too high.</p> <p><i>Remedy:</i> The EPD function cannot be used with fluids of this nature.</p>
463	<p><i>Device status message (FF):</i> EPD adjustment wrong – Err. No. 463</p> <p><i>Local display:</i> P: FULL = EMPTY ⚡: # 463</p>	<p>Transducer_Error = Configuration error</p>	<p>OUT. QUALITY = BAD</p> <p>OUT. SUBSTATUS = Configuration error</p> <p>BLOCK_ERR = Input Failure (faulty input value from Transducer Blocks)</p>	<p><i>Cause:</i> The EPD adjustment values for empty pipe and full pipe are identical and therefore incorrect.</p> <p><i>Remedy:</i> Repeat adjustment, making sure procedure is correct → 74.</p>
467	<p><i>Device status message (FF):</i> AO Block Error– Err. No. 467</p> <p><i>Local display:</i> P: AO-BLOCK ERROR ⚡: # 467</p>	<p>BLOCK_ERR = Device needs maintenance now</p> <p>Transducer_Error = Data integrity error</p>	<p>OUT.QUALITY = BAD</p> <p>OUT.SUBSTATUS = Device Failure</p>	<p><i>Cause:</i> The value transmitted to the AO block is 0.</p> <p><i>Remedy:</i> Please ensure that the value transmitted to the AO block is greater than 0 → 68.</p>

9.3 Process errors without a message

Symptoms	Rectification
 Note! You may have to change or correct certain settings in functions in the function matrix in order to rectify the fault. The functions outlined below, such as DISPLAY DAMPING, are described in detail in the "Description of Device Functions" manual.	
Flow values are negative, even though the fluid is flowing forwards through the pipe.	Change the sign of the flow rate variable. <ol style="list-style-type: none"> FF: "Flow" Transducer Block (base index: 1400) → "Sys. – Install.Direction Sensor" parameter Local display: HOME → BASIC FUNCTION → SYSTEM PARAMETER → CONFIGURATION → INSTALLATION DIRECTION SENSOR
Measured value reading fluctuates even though flow is steady.	<ol style="list-style-type: none"> Check grounding and potential equalization →  53 The medium is too inhomogeneous. Check the following medium characteristics: <ul style="list-style-type: none"> Gas bubble percentage too high? Solids percentage too high? Conductivity fluctuations too high? Increase the value for system damping: <ul style="list-style-type: none"> FF: Analog Input function block → PV_FTIME parameter FF: "Flow" Transducer Block (base index: 1400) → "Sys. – Flow Damping" parameter Local display: HOME → BASIC FUNCTION → SYSTEM PARAMETER → CONFIGURATION → SYSTEM DAMPING Increase the value for display damping: <ul style="list-style-type: none"> FF: "Display" Transducer Block (base index: 1800) → "Config. – Display Damping" parameter Local display: HOME → USER INTERFACE → CONTROL → BASIC CONFIG. → DISPLAY DAMPING
Measured-value reading or measured-value output pulsates or fluctuates, e.g. because of reciprocating pump, peristaltic pump, diaphragm pump or pump with similar delivery characteristic.	<ol style="list-style-type: none"> Increase the value for system damping: <ul style="list-style-type: none"> FF: Analog Input function block → PV_FTIME parameter FF: "Flow" Transducer Block (base index: 1400) → "Sys. – Flow Damping" parameter Local display: HOME → BASIC FUNCTION → SYSTEM PARAMETER → CONFIGURATION → SYSTEM DAMPING Increase the value for display damping: <ul style="list-style-type: none"> FF: "Display" Transducer Block (base index: 1800) → "Config. – Display Damping" parameter Local display: HOME → USER INTERFACE → CONTROL → BASIC CONFIG. → DISPLAY DAMPING
Measured value reading shown on display, even though the fluid is at a standstill and the measuring tube is full?	<ol style="list-style-type: none"> Check grounding and potential equalization →  53 Check the fluid for presence of gas bubbles. Enter or increase the value (>0) for the switching point of low flow cutoff: <ul style="list-style-type: none"> FF: "Flow" Transducer Block (base index: 1400) → "Low Flow Cut Off – On Value" parameter Local display: HOME → BASIC FUNCTION → PROCESS PARAMETER → CONFIGURATION → ON VALUE LF CUT OFF
Measured-value reading on display, even though measuring tube is empty.	<ol style="list-style-type: none"> Perform empty pipe/full pipe adjustment and then switch on empty pipe detection →  74. Fill the measuring tube.
The fault cannot be rectified or some other fault not described above has arisen. In these instances, please contact your Endress+Hauser service organization.	The following options are available for tackling problems of this nature: <ul style="list-style-type: none"> Request the services of an Endress+Hauser service technician If you contact our service organization to have a service technician sent out, please be ready to quote the following information: <ul style="list-style-type: none"> Brief description of the fault Nameplate specifications: order code and serial number →  6 Returning devices to Endress+Hauser The necessary procedures must be carried out before you return a flowmeter requiring repair or calibration to Endress+Hauser →  99 Always enclose a duly completed "Declaration of Contamination" form with the flowmeter. You will find a preprinted "Declaration of Contamination" form at the back of this manual. Replace transmitter electronics Components in the measuring electronics defective → Order spare parts →  91.

9.4 Spare parts

You will find detailed troubleshooting instructions in the preceding sections → 80. The measuring device, moreover, provides additional support in the form of continuous self-diagnosis and error messages.

Fault rectification can entail replacing defective components with tested spare parts. The illustration below shows the available scope of spare parts.



Note!

You can order spare parts directly from your Endress+Hauser service organization by providing the serial number printed on the transmitter nameplate → 6.

Spare parts are shipped as sets comprising the following parts:

- Spare part
- Additional parts, small items (screws, etc.)
- Mounting instructions
- Packaging

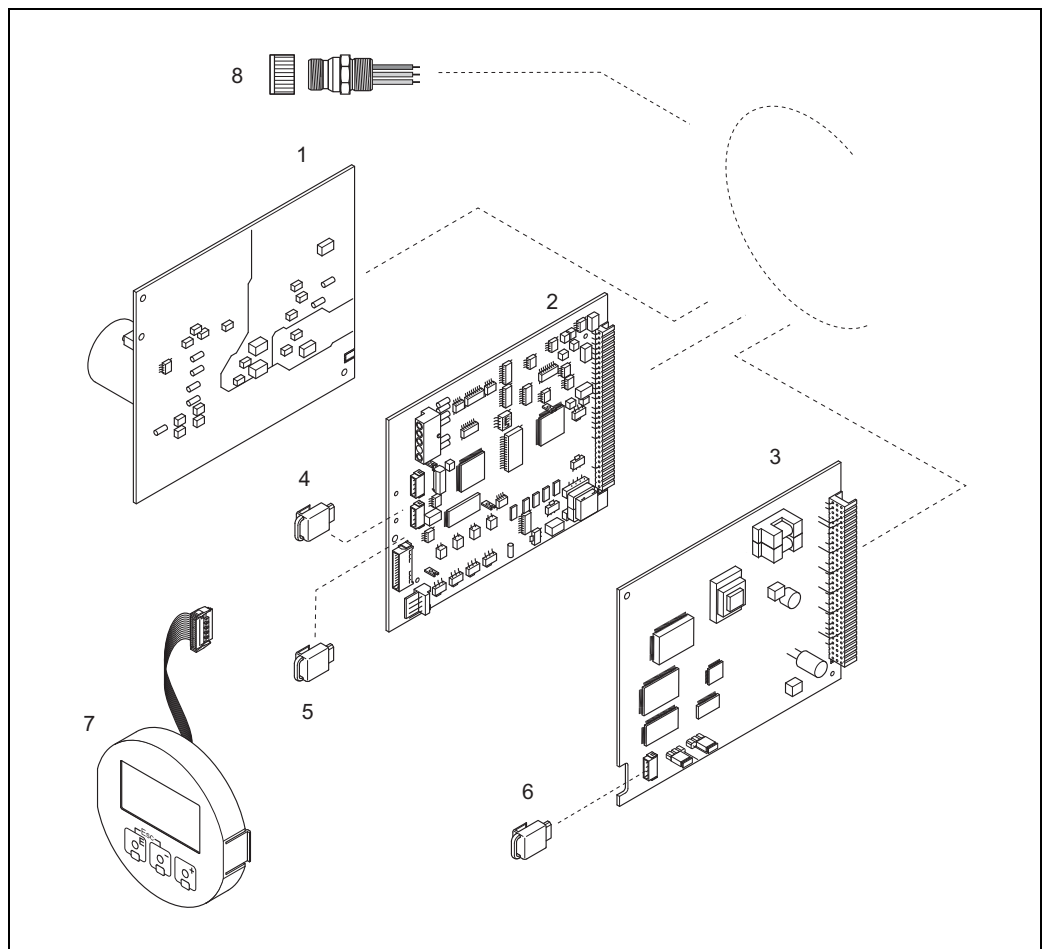

Fig. 47: Spare parts for Promag transmitter (field and wall-mount housing)

- 1 Power unit board
- 2 Amplifier board
- 3 I/O board (FOUNDATION Fieldbus type)
- 4 S-DAT (sensor data storage device)
- 5 T-DAT (transmitter data storage device)
- 6 F-CHIP (function chip for optional software)
- 7 Display module
- 8 Fieldbus connector

9.4.1 Removing and installing electronics boards

Field housing



Warning!

- Risk of electric shock. Exposed components carry dangerous voltages. Make sure that the power supply is switched off before you remove the cover of the electronics compartment.
- Risk of damaging electronic components (ESD protection). Static electricity can damage electronic components or impair their operability. Use a workplace with a grounded working surface purpose-built for electrostatically sensitive devices!
- If you cannot guarantee that the dielectric strength of the device is maintained in the following steps, then an appropriate inspection must be carried out in accordance with the manufacturer's specifications.



Caution!

Use only original Endress+Hauser parts.

Installing and removing the boards →  48:

1. Unscrew cover of the electronics compartment from the transmitter housing.
2. Remove the local display (1) as follows:
 - Press in the latches (1.1) at the side and remove the display module.
 - Disconnect the ribbon cable (1.2) of the display module from the amplifier board.
3. Remove the screws and remove the cover (2) from the electronics compartment.
4. Remove power unit board (4) and I/O board (6):
Insert a thin pin into the hole provided (3) and pull the board clear of its holder.
5. Remove amplifier board (5):
 - Disconnect the plug of the electrode signal cable (5.1) including S-DAT (5.3) from the board.
 - Loosen the plug locking of the coil current cable (5.2) and gently disconnect the plug from the board, i.e. without moving it to and fro.
 - Insert a thin pin into the hole provided (3) and pull the board clear of its holder.
6. Installation is the reverse of the removal procedure.

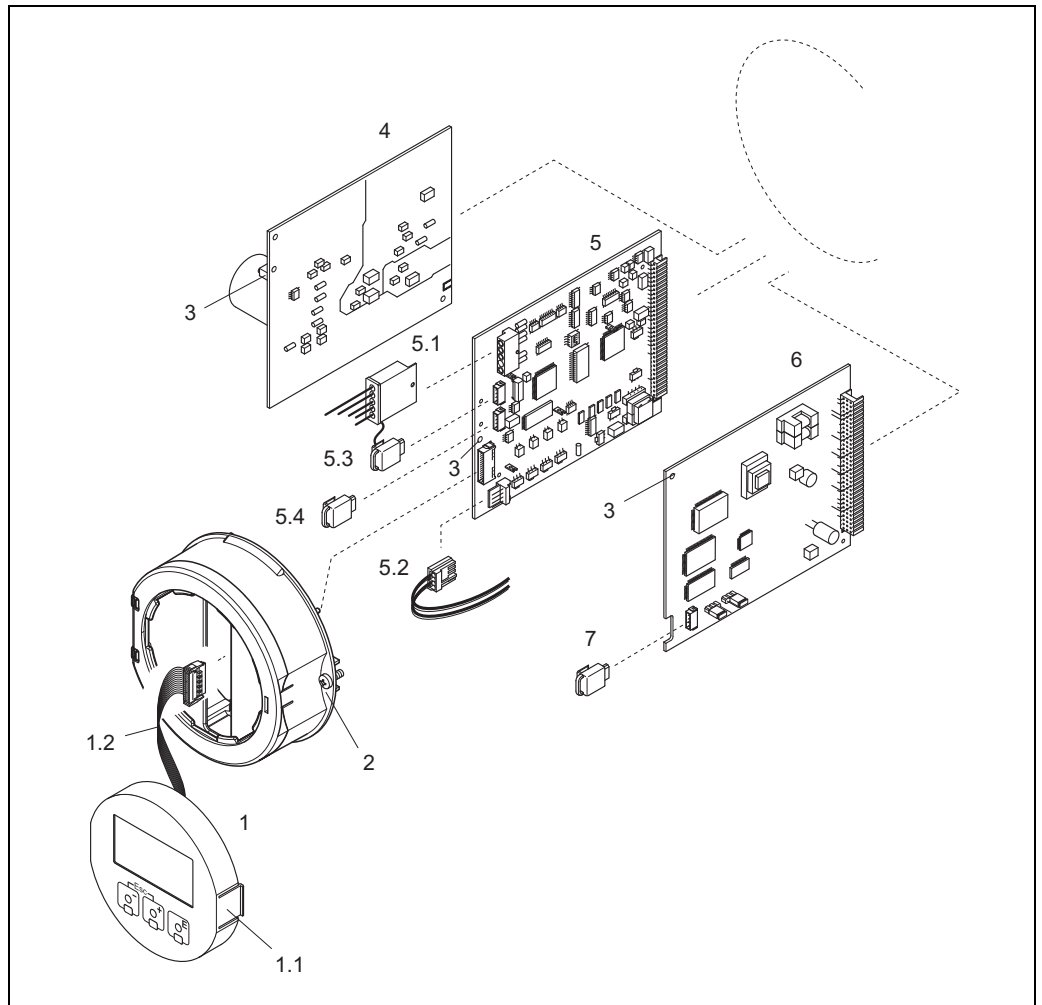

a0006393

Fig. 48: Field housing: removing and installing electronics boards

- 1 Local display
- 1.1 Latch
- 1.2 Ribbon cable (display module)
- 2 Screws for electronics compartment cover
- 3 Aperture for installing /removing boards
- 4 Power unit board
- 5 Amplifier board
- 5.1 Electrode signal cable (sensor)
- 5.2 Coil current cable (sensor)
- 5.3 S-DAT (sensor data storage device)
- 5.4 T-DAT (transmitter data storage device)
- 6 I/O board (FOUNDATION Fieldbus type)
- 7 F-CHIP (function chip for optional software)

Wall-mount housing



Warning!

- Risk of electric shock. Exposed components carry dangerous voltages. Make sure that the power supply is switched off before you remove the cover of the electronics compartment.
- Risk of damaging electronic components (ESD protection). Static electricity can damage electronic components or impair their operability. Use a workplace with a grounded working surface purpose-built for electrostatically sensitive devices!
- If you cannot guarantee that the dielectric strength of the device is maintained in the following steps, then an appropriate inspection must be carried out in accordance with the manufacturer's specifications.



Caution!

Use only original Endress+Hauser parts.

Installing and removing the boards →  49:

1. Remove the screws and open the hinged cover (1) of the housing.
2. Loosen the screws securing the electronics module (2). Then push up electronics module and pull it as far as possible out of the wall-mount housing.
3. Disconnect the following cable plugs from amplifier board (7):
 - Electrode signal cable plug (7.1) including S-DAT (7.3)
 - Plug of coil current cable (7.2): To do so, loosen the plug locking of the coil current cable (7.2) and carefully disconnect the plug from the board, i.e. without moving it to and fro.
 - Ribbon cable plug (3) of the display module
4. Remove the cover (4) from the electronics compartment by loosening the screws.
5. Removing boards (6, 7, 8):
Insert a thin pin into the hole provided (5) and pull the board clear of its holder.
6. Installation is the reverse of the removal procedure.

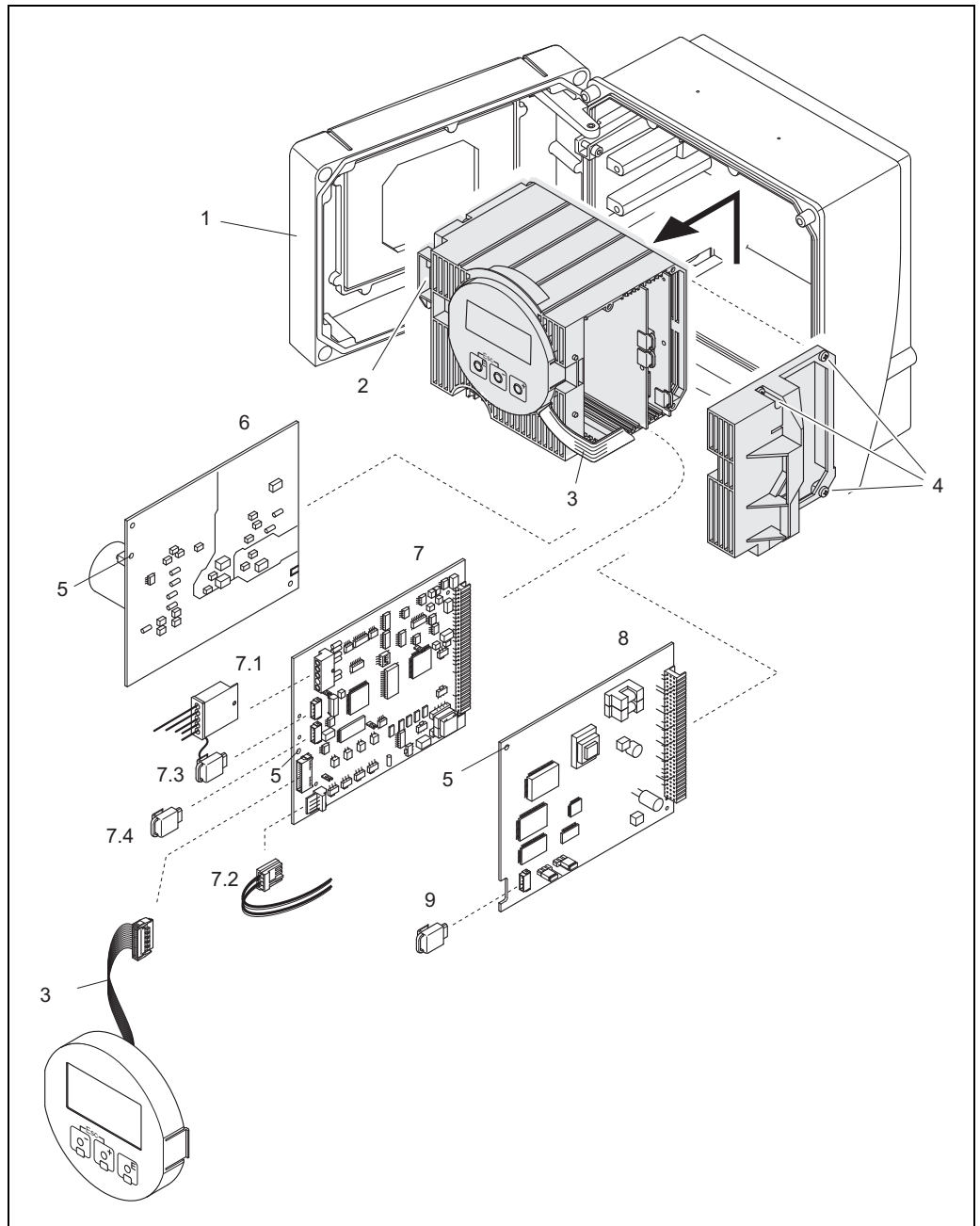

Fig. 49: Wall-mount housing: removing and installing electronics boards

- 1 Housing cover
- 2 Electronics module
- 3 Ribbon cable (display module)
- 4 Screws for electronics compartment cover
- 5 Aperture for installing /removing boards
- 6 Power unit board
- 7 Amplifier board
- 7.1 Electrode signal cable (sensor)
- 7.2 Coil current cable (sensor)
- 7.3 S-DAT (sensor data storage device)
- 7.4 T-DAT (transmitter data storage device)
- 8 I/O board (FOUNDATION Fieldbus type)
- 9 F-CHIP (function chip for optional software)

9.4.2 Replacing the device fuse



Warning!

Risk of electric shock. Exposed components carry dangerous voltages. Make sure that the power supply is switched off before you remove the cover of the electronics compartment.

The main fuse is on the power supply board →  50.

The procedure for replacing the fuse is as follows:

1. Switch off power supply.
2. Remove power unit board →  92.
3. Remove cap (1) and replace the device fuse (2).
Use only the following types of fuses:
 - 85 to 260 V AC: 0.8 A slow-blow / 250 V
 - 20 to 55 V AC and 16 to 62 V DC: 2 A slow-blow / 250 V
 - Ex-rated devices → See the Ex documentation
4. Installation is the reverse of the removal procedure.



Caution!

Use only original Endress+Hauser parts.

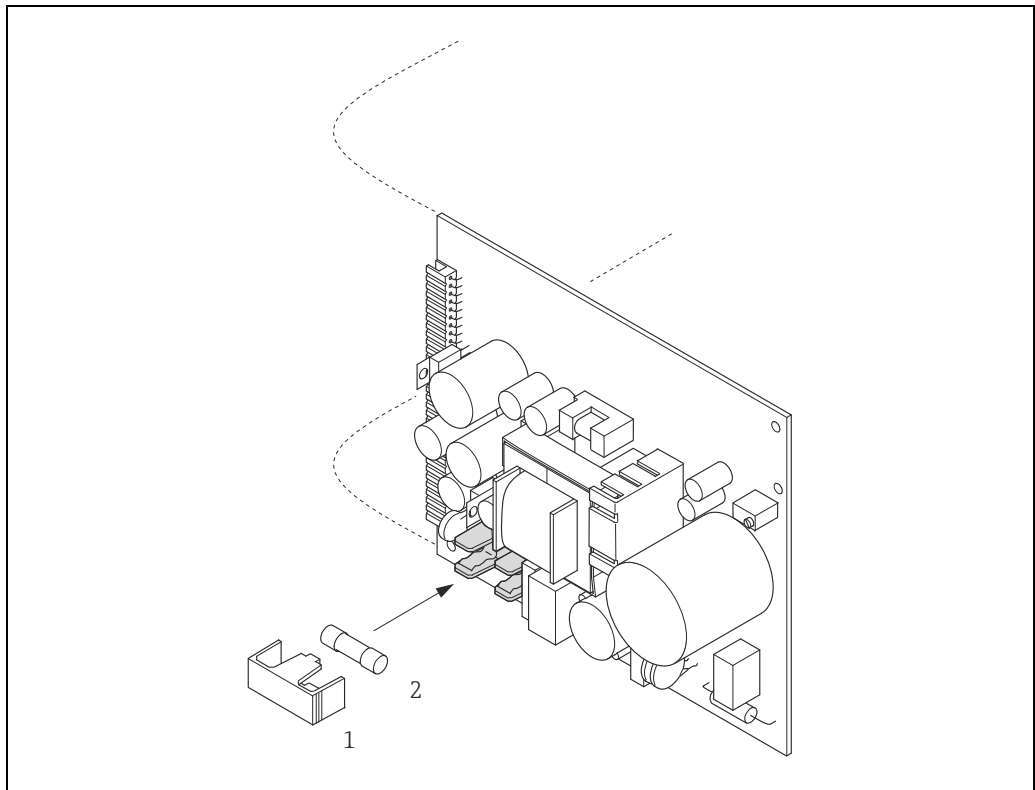

Fig. 50: Replacing the device fuse on the power supply board

- 1 Protection cap
- 2 Device fuse

9.4.3 Replacing the exchangeable electrode

The Promag W sensor (DN 350 to 2000 / 14 to 78") can be supplied with optional exchangeable measuring electrodes. This design allows the measuring electrodes to be exchanged or cleaned under process conditions.

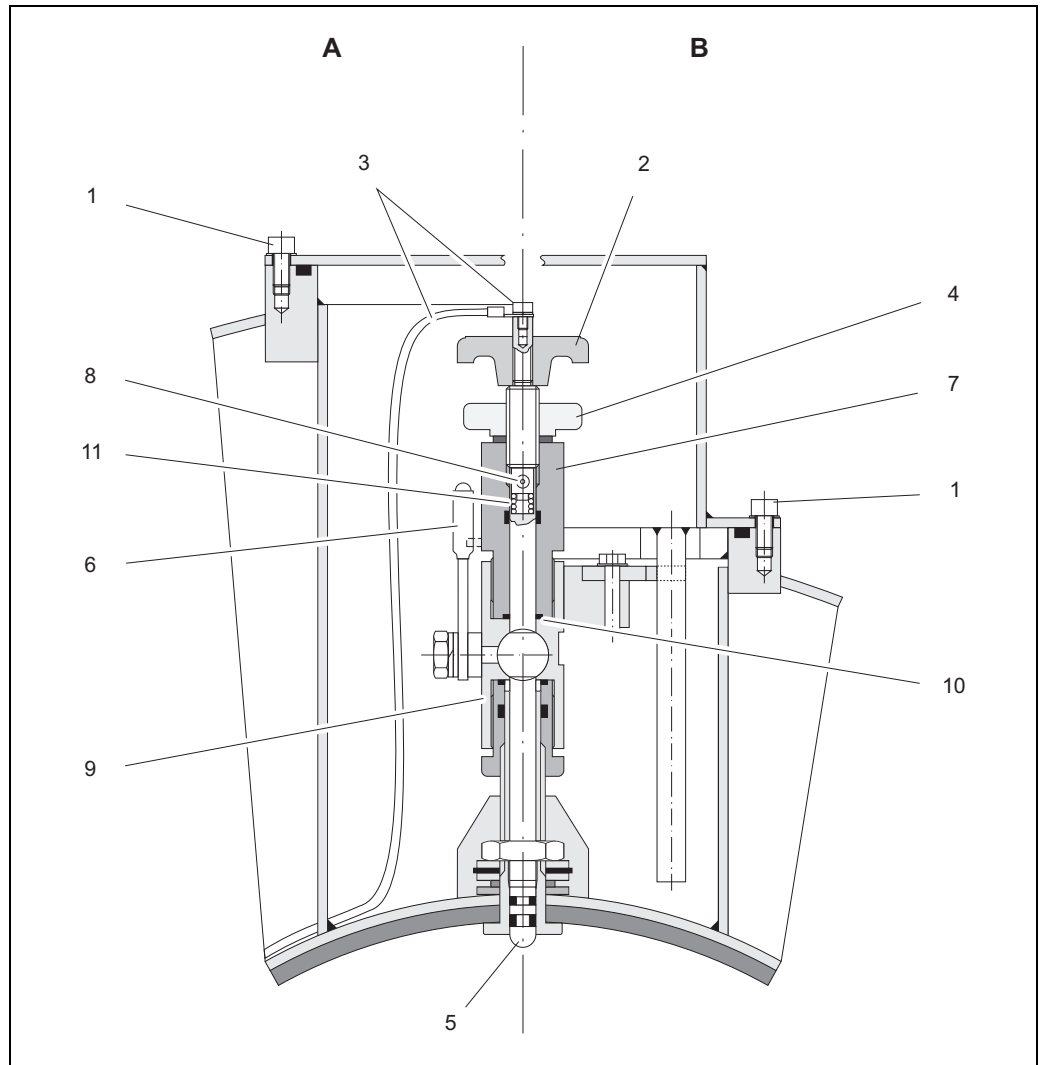







Fig. 51: Device for replacing the exchangeable measuring electrodes

View A = DN 1200 to 2000 (48 to 78")

View B = DN 350 to 1050 (14 to 42")

- 1 Socket head cap screw
- 2 Rotary handle
- 3 Electrode cable
- 4 Knurled nut (counter nut)
- 5 Measuring electrode
- 6 Stop cock (ball valve)
- 7 Retaining cylinder
- 8 Locking bolt (rotary handle)
- 9 Ball valve housing
- 10 Seal (retaining cylinder)
- 11 Coil spring

Removing the electrode	Fitting the electrode
<p>1 Release the socket head cap screw (1) and remove the cap.</p>	<p>1 Insert the new electrode (5) from underneath into the retaining cylinder (7). Ensure that the seals at the tip of the electrode are clean.</p>
<p>2 Unscrew the electrode cable (3) secured on the rotary handle (2).</p>	<p>2 Attach the rotary handle (2) to the electrode and secure with the locking bolt (8).  Caution! Ensure that the coil spring (11) is inserted to guarantee perfect electrical contact and thus correct measuring signals.</p>
<p>3 Release the knurled nut (4) by hand. This knurled nut serves as a counter nut.</p>	<p>3 Pull the electrode back until the tip is no longer protruding from the retaining cylinder (7).</p>
<p>4 Unscrew the electrode (5) using the rotary handle (2). It can now be pulled out of the retaining cylinder (7) up to a defined point.  Warning! Risk of injury! The electrode can bounce back to its stop under process conditions (pressure in the pipe). Exert counter pressure against it when releasing.</p>	<p>4 Screw the retaining cylinder (7) onto the ball valve housing (9) and secure tightly by hand. The seal (10) at the retaining cylinder must be fitted and clean.  Note! Ensure that the rubber hoses attached to the retaining cylinder (7) and stop cock (6) are the same color (red or blue).</p>
<p>5 Close the stop cock (6) after you have pulled out the electrode as far as it will go.  Warning! Do not open the stop cock after this to ensure that no fluid comes out.</p>	<p>5 Open the stop cock (6) and screw the electrode as far as it will go into the retaining cylinder using the rotary handle (2).</p>
<p>6 You can now unscrew the entire electrode with the retaining cylinder (7).</p>	<p>6 Now, screw the knurled nut (4) on the retaining cylinder. This secures the electrode in position.</p>
<p>7 Remove the rotary handle (2) from the electrode (5) by pushing out the locking bolt (8). Ensure that you do not lose the coil spring (11).</p>	<p>7 Secure the electrode cable (3) on the rotary handle (2) once more using the socket head cap screw.  Caution! Ensure that the socket head cap screw of the electrode cable is securely tightened. This guarantees perfect electrical contact and thus correct measuring signals.</p>
<p>8 Now replace the old electrode with the new one. You can order replacement electrodes separately from Endress+Hauser</p>	<p>8 Refit the cover and tighten the socket head cap screw (a).</p>

9.5 Return



Caution!

Do not return a measuring device if you are not absolutely certain that all traces of hazardous substances have been removed, e.g. substances which have penetrated crevices or diffused through plastic.

Costs incurred for waste disposal and injury (burns, etc.) due to inadequate cleaning will be charged to the owner-operator.

The following steps must be taken before returning a flow measuring device to Endress+Hauser, e.g. for repair or calibration:

- Always enclose a duly completed "Declaration of contamination" form. Only then can Endress+Hauser transport, examine and repair a returned device.
- Enclose special handling instructions if necessary, for example a safety data sheet as per EC REACH Regulation No. 1907/2006.
- Remove all residues. Pay special attention to the grooves for seals and crevices which could contain residues. This is particularly important if the substance is hazardous to health, e.g. flammable, toxic, caustic, carcinogenic, etc.



Note!

You will find a preprinted "Declaration of contamination" form at the back of these Operating Instructions.

9.6 Disposal

Please observe the regulations applicable in your country or region.

9.7 Software history

Date	Software-Version	Changes to software	Documentation
10.2009	3.00.XX	Introduction of new FOUNDATION Fieldbus I/O board Reduced execution times: Analog Input function blocks 1 to 5 (18 ms) PID function block (25 ms) Discrete Output function block (18 ms) Integrator function block (18 ms) Software adjustments: - ITK version: 5.01 - CFF version: 1.8	71089880/07.09
01.2007	2.00.XX	New execution times: ▪ Analog Input function blocks 1 to 5 (20 ms) ▪ Discrete Output function block (20 ms) ▪ PID function block (50 ms) New function blocks: ▪ Arithmetic function block (20 ms) ▪ Input Selector function block (20 ms) ▪ Signal Characterizer function block (20 ms) ▪ Integrator function block (25 ms) Method: ▪ Communication ▪ Commissioning ITK version: 5.01	71031357/09.06
09.2006	1.01.02	Original software	71031357/09.06

10 Technical data

10.1 Technical data at a glance

10.1.1 Application

→ 4

10.1.2 Function and system design

Measuring principle

Electromagnetic flow measurement on the basis of Faraday's Law.

Measuring system

→ 6

10.1.3 Input

Measured variable

Flow rate (proportional to induced voltage)

Measuring range

Typical $v = 0.01$ to 10 m/s (0.03 to 33 ft/s) with the specified measuring accuracy

Operable flow range

Over 1000 : 1

10.1.4 Output

Output signal

Physical data transmission (Physical Layer Type):

- Fieldbus interface in accordance with IEC 61158-2
- Corresponds to device version type 112 of the FOUNDATION Fieldbus specification: type 112 standard data transfer (± 9 mA, symmetrical), separate supply to field device (4-wire), intrinsically safe version of the FF interface
- With integrated reverse polarity protection

Signal on alarm

Status messages as per FOUNDATION Fieldbus specification

Link Master (LM) support

Yes

Link Master (factory setting)/Basic Device can be selected

Yes

Device basic current

12 mA

Device starting current

< 12 mA

Device error current (FDE)

0 mA

Device (lift off) min. voltage

9 V (H1 segment)

Permissible fieldbus supply voltage

9 to 32 V

Integrated reverse polarity protection

Yes

ITK version

5.01

Number of VCRs (total)

38

Number of link objects in VFD

40

Galvanic isolation

All circuits for inputs, outputs and power supply are galvanically isolated from each other.

Data transmission rate

31.25 kbit/s, voltage mode

Bus times

Min. idle time between two telegrams:

MIN_INTER_PDU_DELAY = 6 octet time (transfer time per octet)

Block information, execution times

Block	Base index	Execution time [ms]	Functionality
Resource Block	400	–	Enhanced
"Flow" Transducer Block	1400	–	Vendor specific
"Diagnosis" Transducer Block	1600	–	Vendor specific
"Display" Transducer Block	1800	–	Vendor specific
"Totalizer" Transducer Block	1900	–	Vendor specific
Analog Input function block 1	500	18	Standard
Analog Input function block 2	550	18	Standard
Analog Input function block 3	600	18	Standard
Analog Input function block 4	650	18	Standard
Analog Input function block 5	700	18	Standard
Discrete Output function block (DO)	850	18	Standard

Block	Base index	Execution time [ms]	Functionality
PID function block (PID)	900	25	Standard
Arithmetic function block (ARTH)	1000	20	Standard
Input Selector function block (ISEL)	1050	20	Standard
Signal Characterizer function block (CHAR)	1100	20	Standard
Integrator function block (INTG)	1150	18	Standard

Output data

Transducer Blocks/Analog Input function blocks

Block	Process variable	Channel parameter (AI Block)
"Flow" Transducer Block	Calculated mass flow	1
	Volume flow	2
"Totalizer" Transducer Block	Totalizer 1	7
	Totalizer 2	8
	Totalizer 3	9

Input data

Discrete Output function block (channel 16)

Status change	Action
Discrete state 0 → Discrete state 1	reserved
Discrete state 0 → Discrete state 2	Positive zero return "ON"
Discrete state 0 → Discrete state 3	Positive zero return "OFF"
Discrete state 0 → Discrete state 4	reserved
Discrete state 0 → Discrete state 5	reserved
Discrete state 0 → Discrete state 6	reserved
Discrete state 0 → Discrete state 7	Reset Totalizer 1, 2, 3
Discrete state 0 → Discrete state 8	Reset Totalizer 1
Discrete state 0 → Discrete state 9	Reset Totalizer 2
Discrete state 0 → Discrete state 10	Reset Totalizer 3
Discrete state 0 → Discrete state 27	Permanent Storage "OFF"
Discrete state 0 → Discrete state 28	Permanent Storage "ON"

VCRs

VCRs (total 48)	48
Permanent Entries	1
Client VCRs	0
Server VCRs	24
Source VCRs	23
Sink VCRs	0
Subscriber VCRs	23
Publisher VCRs	23

10.1.5 Power supply

Electrical connections

→  41

Supply voltage (power supply)

- 85 to 260 V AC, 45 to 65 Hz
- 20 to 55 V AC, 45 to 65 Hz
- 16 to 62 V DC

Cable entries

Power supply and signal cable (inputs/outputs):

- Cable gland M20 × 1.5 (8 to 12 mm / 0.31 to 0.47")
- Cable gland sensor for armored cables M20 × 1.5 (9.5 to 16 mm / 0.37 to 0.63")
- Cable entries for thread 1/2" NPT, G 1/2"

Connecting cable for remote version:

- Cable gland M20 × 1.5 (8 to 12 mm / 0.31 to 0.47")
- Cable gland sensor for armored cables M20 × 1.5 (9.5 to 16 mm / 0.37 to 0.63")
- Cable entries for thread 1/2" NPT, G 1/2"

Cable specifications (remote version)

FOUNDATION Fieldbus →  41

Remote version →  44

Power consumption

Power consumption

- AC: <15 VA (including sensor)
- DC: <15 W (including sensor)

Switch-on current

- Max. 3 A (<5 ms) at 260 V AC
- Max. 13.5 A (<5 ms) at 24 V AC

Power supply failure

Lasting min. 1 power cycle:

- EEPROM or HistoROM/T-DAT saves measuring system data if power supply fails
- HistoROM/S-DAT: exchangeable data storage device which stores sensor characteristic data (nominal diameter, serial number, calibration factor, zero point etc.)

Potential equalization

→  53

10.1.6 Performance characteristics

Reference operating conditions

To DIN EN 29104 and VDI/VDE 2641:

- Fluid temperature: +28 °C ± 2 K
- Ambient temperature: +22 °C ± 2 K
- Warm-up time: 30 minutes

Installation:

- Inlet run > 10 × DN
- Outlet run > 5 × DN
- Sensor and transmitter grounded.
- Sensor centered relative to the pipe.

Maximum measured error

Standard: ±0.2% o.r. ± 2 mm/s (o.r. = of reading)



Note!

Supply-voltage fluctuations have no effect within the specified range.

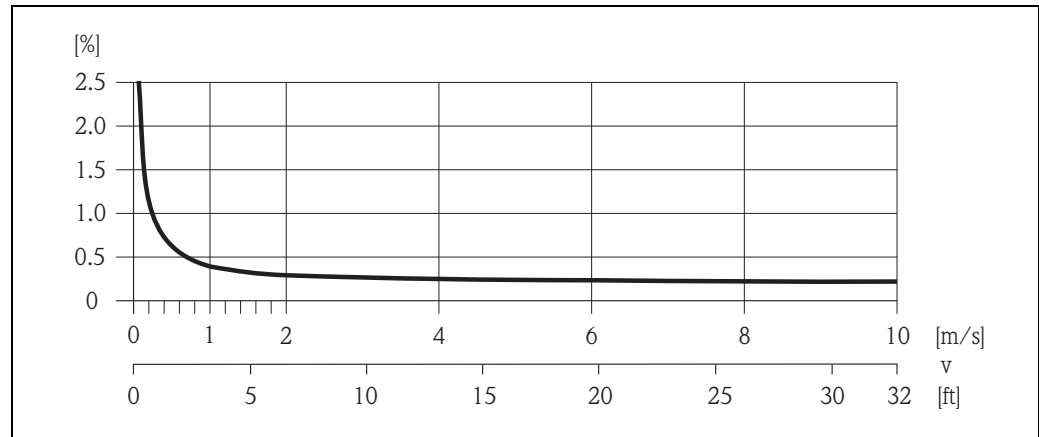

Fig. 52: Max. measured error in % of reading

Repeatability

Standard: max. ±0.1% o.r. ± 0.5 mm/s (o.r. = of reading)

10.1.7 Installation

Installation instructions

→ 12

Inlet and outlet runs

Inlet run: typically ≥ 5 × DN
 Outlet run: typically ≥ 2 × DN

Length of connecting cable

- The permissible cable length L_{max} for the remote version depends on the conductivity of the medium → 19.
- A minimum conductivity of 20 $\mu\text{S}/\text{cm}$ is required to measure demineralized water.

10.1.8 Environment

Ambient temperature range

Transmitter:

- Standard: -20 to +60 °C (-4 to +140 °F)
- Optional: -40 to +60 °C (-40 to +140 °F)

**Note!**

At ambient temperatures below -20 °C (-4 °F), the readability of the display may be impaired.

Sensor:

- Flange material carbon steel: $-10\text{ to }+60\text{ °C}$ ($+14\text{ to }+140\text{ °F}$)
- Flange material stainless steel: $-40\text{ to }+60\text{ °C}$ ($-40\text{ to }+140\text{ °F}$)

**Caution!**

Do not exceed the min. and max. temperatures for the lining of the measuring tube (→ "Medium temperature range").

Note the following points:

- Install the device at a shady location. Avoid direct sunlight, particularly in warm climatic regions.
- If both fluid and ambient temperatures are high, install the transmitter at a remote location from the sensor (→ "Medium temperature range").

Storage temperature

The storage temperature corresponds to the operating temperature range of the transmitter and sensor.

**Caution!**

- The measuring device must be protected against direct sunlight during storage in order to avoid unacceptably high surface temperatures.
- Choose a storage location where moisture does not collect in the measuring device. This will help prevent fungus and bacteria infestation which can damage the lining.

Degree of protection

- Standard: IP 67 (NEMA 4X) for transmitter and sensor
- Optional: IP 68 (NEMA 6P) for remote version of Promag W and Promag P sensors

Shock and vibration resistance

Acceleration up to 2 g in accordance with IEC 600 68-2-6
(High-temperature version: no data available)

CIP cleaning**Caution!**

The maximum fluid temperature permitted for the measuring device must not be exceeded.

CIP cleaning possible:

Promag E (110 °C / 230 °F), Promag H/P

CIP cleaning not possible:

Promag W

SIP cleaning**Caution!**

The maximum fluid temperature permitted for the measuring device must not be exceeded.

SIP cleaning possible:

Promag H, Promag P (with PFA lining)

SIP cleaning not possible:

Promag E/W

Electromagnetic compatibility (EMC)

According to IEC/EN 61326 and NAMUR recommendation NE 21

10.1.9 Process

Medium temperature range

The permitted temperature depends on the lining of the measuring tube:

Promag E

PTFE: -10 to +110 °C (+14 to +230 °F)



Abb. 53: Compact and remote version (T_A = Ambient temperature, T_F = Fluid temperature)

Promag H

Sensor:

- DN 2 to 25 (1/12 to 1"): -20 to +150 °C (-4 to +302 °F)
- DN 40 to 100 (1 ½ to 4"): -20 to +150 °C (-4 to +302 °F)

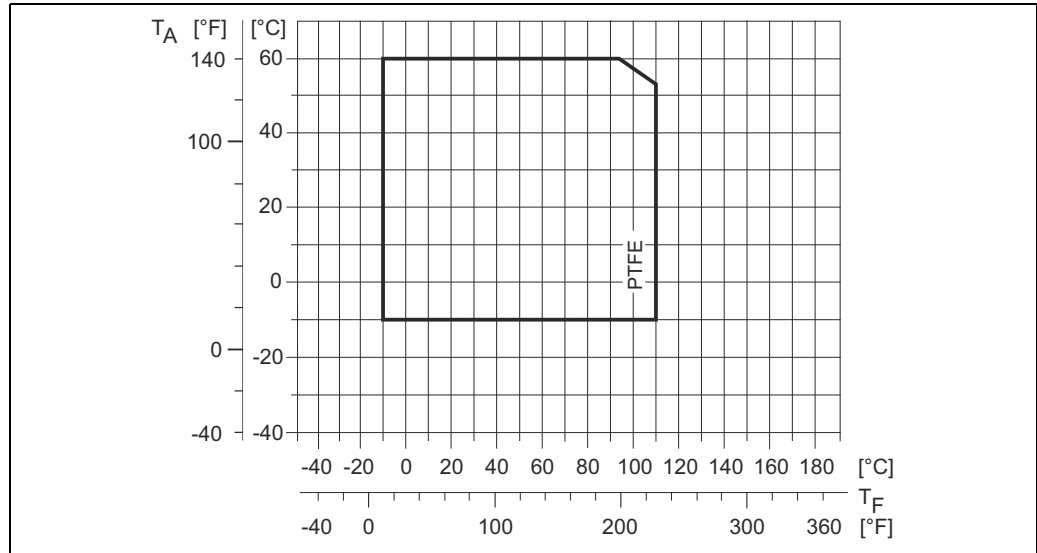
Seals:

- EPDM: -20 to +150 °C (-4 to +302 °F)
- Silicone: -20 to +150 °C (-4 to +302 °F)
- Viton: -20 to +150 °C (-4 to +302 °F)
- Kalrez: -20 to +150 °C (-4 to +302 °F)

Promag P

Standard

- -40 to +130 °C (-40 to +266 °F) for PTFE (DN 15 to 600 / ½ to 24"), restrictions → see diagrams below
- -20 to +130 °C (-4 to +266 °F) for PFA/HE (DN 25 to 200 / 1 to 8"), restrictions → see diagrams below
- -20 to +150 °C (-4 to +302 °F) for PFA (DN 25 to 200 / 1 to 8"), restrictions → see diagrams below

Optional

High-temperature version (HT): -20 to +180 °C (-4 to +356 °F) for PFA (DN 25 to 200 / 1 to 8")

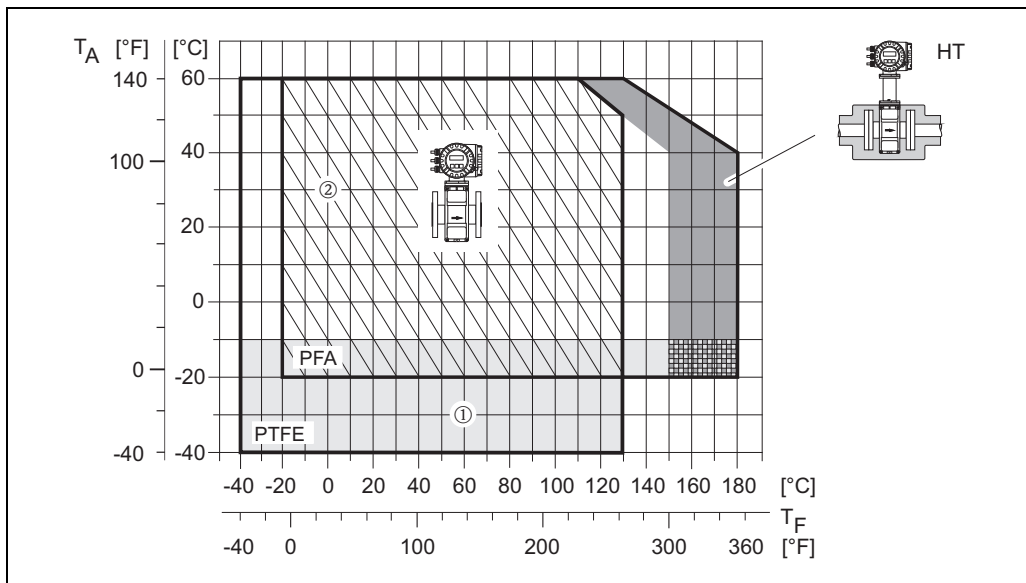

Fig. 54: Promag P compact version (with PFA or PTFE lining)

T_A = ambient temperature; T_F = fluid temperature; HT = high-temperature version with insulation

① = Light gray area → temperature range from -10 to -40 °C (-14 to -40 °F) applies only to stainless steel flanges

② = Diagonally hatched area → foam lining (HE) + degree of protection IP68 = fluid temperature max. 130 °C (266 °F)

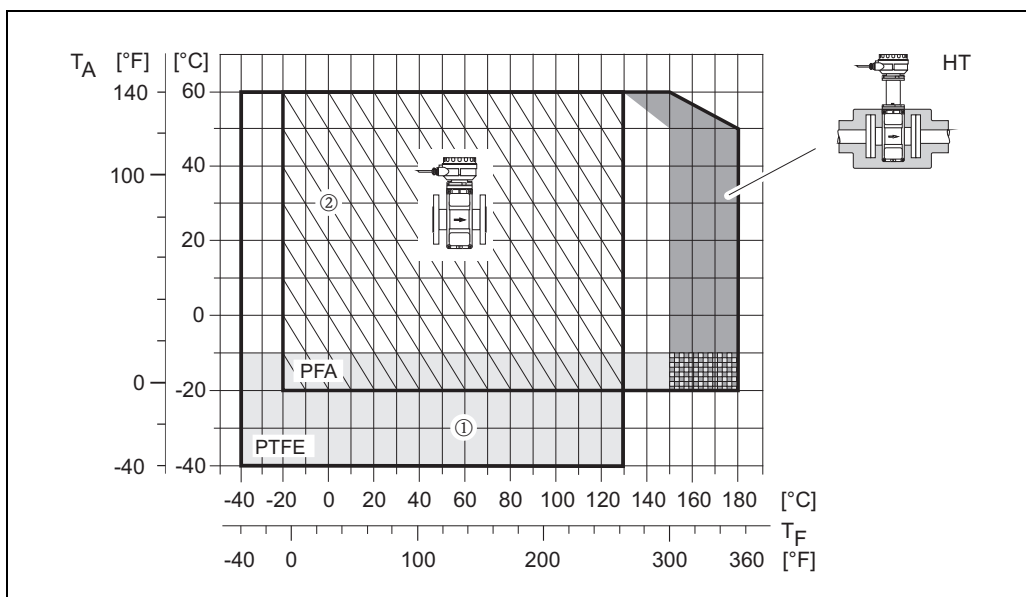

Fig. 55: Remote versions (with PFA or PTFE lining)

T_A = ambient temperature; T_F = fluid temperature; HT = high-temperature version with insulation

① = Light gray area → temperature range from -10 to -40 °C (-14 to -40 °F) applies only to stainless steel flanges

② = Diagonally hatched area → foam lining (HE) + degree of protection IP68 = fluid temperature max. 130 °C (266 °F)

Promag W

- 0 to +80 °C (+32 to +176 °F) for hard rubber (DN 65 to 2000 / 2½ to 80")
- -20 to +50 °C (-4 to +122 °F) for polyurethane (DN 25 to 1200 / 1 to 48")

Conductivity of the fluid

The minimum conductivity is $\geq 5 \mu\text{S/cm}$ (for demineralized water $\geq 20 \mu\text{S/cm}$)



Note!

In the remote version, the required minimum conductivity is also influenced by the length of the connecting cable → 19.

Limiting medium pressure range (nominal pressure)*Promag E*

- EN 1092-1 (DIN 2501)
 - PN 10 (DN 200 to 600 / 8 to 24")
 - PN 16 (DN 65 to 600 / 3 to 24")
 - PN 40 (DN 15 to 150 / ½ to 2")
- ASME B 16.5
 - Class 150 (½ to 24")
- JIS B2220
 - 10K (DN 50 to 300 / 2 to 12")
 - 20K (DN 15 to 40 / ½ to 1½")

Promag H

The permissible nominal pressure depends on the process connection and the seal:

- 40 bar → flange, weld nipple (with O-ring seal)
- 16 bar → all other process connections

Promag P

- EN 1092-1 (DIN 2501)
 - PN 10 (DN 200 to 600 / 8 to 24")
 - PN 16 (DN 65 to 600 / 3 to 24")
 - PN 25 (DN 200 to 600 / 8 to 24")
 - PN 40 (DN 25 to 150 / 1 to 6")
- ASME B 16.5
 - Class 150 (1 to 24")
 - Class 300 (1 to 6")
- JIS B2220
 - 10K (DN 50 to 300 / 2 to 12")
 - 20K (DN 25 to 300 / 1 to 12")
- AS 2129
 - Table E (DN 25 / 1"), 50 / 2")
- AS 4087
 - PN 16 (DN 50 / 2")

Promag W

- EN 1092-1 (DIN 2501)
 - PN 6 (DN 350 to 2000 / 14 to 84")
 - PN 10 (DN 200 to 2000 / 8 to 84")
 - PN 16 (DN 65 to 2000 / 3 to 84")
 - PN 25 (DN 200 to 1000 / 8 to 40")
 - PN 40 (DN 25 to 150 / 1 to 6")
- ASME B 16.5
 - Class 150 (1 to 24")
 - Class 300 (1 to 6")
- AWWA
 - Class D (28 to 78")
- JIS B2220
 - 10K (DN 50 to 300 / 2 to 12")
 - 20K (DN 25 to 300 / 1 to 12")
- AS 2129
 - Table E (DN 80 / 3", 100 / 4", 150 to 1200 / 6 to 48")
- AS 4087
 - PN 16 (DN 80 / 3", 100 / 4", 150 to 1200 / 6 to 48")

Pressure tightness (measuring tube lining)*Promag E (Measuring tube lining: PTFE)*

Nominal diameter		Resistance of measuring tube lining to partial vacuum Limit values for abs. pressure [mbar] ([psi]) at various fluid temperatures							
[mm]	[inch]	25 °C		80 °C		100 °C		110 °C	
		77 °F		176 °F		212 °F		230 °F	
		[mbar]	[psi]			[mbar]	[psi]	[mbar]	[psi]
15	½"	0	0	0	0	0	0	100	1.45
25	1"	0	0	0	0	0	0	100	1.45
32	-	0	0	0	0	0	0	100	1.45
40	1 ½"	0	0	0	0	0	0	100	1.45
50	2"	0	0	0	0	0	0	100	1.45
65	-	0	0	*	*	40	0.58	130	1.89
80	3"	0	0	*	*	40	0.58	130	1.89
100	4"	0	0	*	*	135	1.96	170	2.47
125	-	135	1.96	*	*	240	3.48	385	5.58
150	6"	135	1.96	*	*	240	3.48	385	5.58
200	8"	200	2.90	*	*	290	4.21	410	5.95
250	10"	330	4.79	*	*	400	5.80	530	7.69
300	12"	400	5.80	*	*	500	7.25	630	9.14
350	14"	470	6.82	*	*	600	8.70	730	10.59
400	16"	540	7.83	*	*	670	9.72	800	11.60
450	18"	Partial vacuum is impermissible!							
500	20"								
600	24"								
* No value can be quoted.									

Promag H (measuring tube lining: PFA)

Nominal diameter		Pressure tightness, measuring tube lining: limit values for absolute pressure [mbar] ([psi]) at various fluid temperature					
[mm]	[inch]	25 °C	80 °C	100 °C	130 °C	150 °C	180 °C
		77 °F	176 °F	212 °F	266 °F	302 °F	356 °F
2 to 100	1/12 to 4"	0	0	0	0	0	0

Promag P (Measuring tube lining: PFA)

Nominal diameter		Resistance of measuring tube lining to partial vacuum: limit values for absolute pressure [mbar] ([psi]) at various fluid temperatures					
[mm]	[inch]	25 °C	80 °C	100 °C	130 °C	150 °C	180 °C
		77 °F	176 °F	212 °F	266 °F	302 °F	356 °F
25	1"	0	0	0	0	0	0
32	-	0	0	0	0	0	0
40	1 ½"	0	0	0	0	0	0
50	2"	0	0	0	0	0	0
65	-	0	*	0	0	0	0
80	3"	0	*	0	0	0	0
100	4"	0	*	0	0	0	0
125	-	0	*	0	0	0	0
150	6"	0	*	0	0	0	0
200	8"	0	*	0	0	0	0
* No value can be quoted.							

Promag P (Measuring tube lining: PTFE)

Nominal diameter		Resistance of measuring tube lining to partial vacuum: limit values for absolute pressure [mbar] ([psi]) at various fluid temperatures								
[mm]	[inch]	25 °C		80 °C	100 °C		130 °C		150 °C	180 °C
		77 °F		176 °F	212 °F		266 °F		302 °F	356 °F
		[mbar]	[psi]		[mbar]	[psi]	[mbar]	[psi]		
15	½"	0	0	0	0	0	100	1,45	-	-
25	1"	0	0	0	0	0	100	1,45	-	-
32	-	0	0	0	0	0	100	1,45	-	-
40	1 ½"	0	0	0	0	0	100	1,45	-	-
50	2"	0	0	0	0	0	100	1,45	-	-
65	-	0	0	*	40	0,58	130	1,89	-	-
80	3"	0	0	*	40	0,58	130	1,89	-	-
100	4"	0	0	*	135	1,96	170	2,47	-	-
125	-	135	1,96	*	240	3,48	385	5,58	-	-
150	6"	135	1,96	*	240	3,48	385	5,58	-	-
200	8"	200	2,90	*	290	4,21	410	5,95	-	-
250	10"	330	4,79	*	400	5,80	530	7,69	-	-
300	12"	400	5,80	*	500	7,25	630	9,14	-	-
350	14"	470	6,82	*	600	8,70	730	10,59	-	-
400	16"	540	7,83	*	670	9,72	800	11,60	-	-
450	18"	Partial vacuum is impermissible								
500	20"									
600	24"									

* No value can be quoted.

Promag W

Nominal diameter		Measuring tube lining	Resistance of measuring tube lining to partial vacuum: limit values for absolute pressure [mbar] ([psi]) at various fluid temperatures						
[mm]	[inch]		25 °C	50 °C	80 °C	100 °C	130 °C	150 °C	180 °C
			77 °F	122 °F	176 °F	212 °F	266 °F	302 °F	356 °F
25 to 1200	1 to 48"	Polyurethane	0	0	-	-	-	-	-
65 to 2000	3 to 78"	Hard rubber	0	0	0	-	-	-	-

Limiting flow

Further information can be found in the "Nominal diameter and flow rate" → 17 section

Pressure loss

- No pressure loss if the sensor is installed in piping with the same nominal diameter (for Promag H only from DN8).
- Pressure losses for configurations incorporating adapters according to DIN EN 545 → 16.

10.1.10 Mechanical construction

Design / dimensions

The dimensions and face-to-face length of the sensor and transmitter can be found in the separate "Technical Information" documentation for each device which can be downloaded in PDF format from www.endress.com. A list of available "Technical Information" documentation can be found in the "Documentation" →  123 section.

Weight (SI units)

Promag E

Weight data in kg							
Nominal diameter		Compact version				ASME Class 150	JIS 10K
		EN (DIN)					
[mm]	[inch]	PN 6	PN 10	PN 16	PN 40		
15	½"	-	-	-	6.5	6.5	6.5
25	1"	-	-	-	7.3	7.3	7.3
32	-	-	-	-	8.0	-	7.3
40	1½"	-	-	-	9.4	9.4	8.3
50	2"	-	-	-	10.6	10.6	9.3
65	-	-	-	12.0	-	-	11.1
80	3"	-	-	14.0	-	14.0	12.5
100	4"	-	-	16.0	-	16.0	14.7
125	-	-	-	21.5	-	-	21.0
150	6"	-	-	25.5	-	25.5	24.5
200	8"	-	45.0	46.0	-	45.0	41.9
250	10"	-	65.0	70.0	-	75.0	69.4
300	12"	-	70.0	81.0	-	110.0	72.3
350	14"	77.4	88.4	99.4	-	137.4	-
400	16"	89.4	104.4	120.4	-	168.4	-
450	18"	99.4	112.4	133.4	-	191.4	-
500	20"	114.4	132.4	182.4	-	228.4	-
600	24"	155.4	162.4	260.4	-	302.4	-

- Transmitter (compact version): 1.8 kg
- Weight data without packaging material

Nominal diameter		Remote version (without cable)						Transmitter
		Sensor						
[mm]	[inch]	EN (DIN)			ASME	JIS	Wall-mount housing	
		PN 6	PN 10	PN 16	PN 40	Class 150		10K
15	½"	-	-	-	4.5	4.5	4.5	6.0
25	1"	-	-	-	5.3	5.3	5.3	
32	-	-	-	-	6.0	-	5.3	
40	1½"	-	-	-	7.4	7.4	6.3	
50	2"	-	-	-	8.6	8.6	7.3	
65	-	-	-	10.0	-	-	9.1	
80	3"	-	-	12.0	-	12.0	10.5	
100	4"	-	-	14.0	-	14.0	12.7	
125	-	-	-	19.5	-	-	19.0	
150	6"	-	-	23.5	-	23.5	22.5	
200	8"	-	43.0	44.0	-	43.0	39.9	
250	10"	-	63.0	68.0	-	73.0	67.4	
300	12"	-	68.0	79.0	-	108.0	70.3	
350	14"	73.1	84.1	95.1	-	133.1		
400	16"	85.1	100.1	116.1	-	164.1		
450	18"	95.1	108.1	129.1	-	187.1		
500	20"	110.1	128.1	178.1	-	224.1		
600	24"	158.1	158.1	256.1	-	298.1		

- Transmitter (remote version): 3.1 kg
- Weight data without packaging material

Promag H



Note!

The following weights apply to standard pressure ratings and without packaging material.

Nominal diameter	Weight data in [kg]		
	DIN [mm]	Compact version	Remote version (without cable)
			Sensor
2	5.2	2.0	6.0
4	5.2	2.0	6.0
8	5.3	2.0	6.0
15	5.4	1.9	6.0
25	5.5	2.8	6.0
40	6.5	4.5	6.0
50	9.0	7.0	6.0
65	9.5	7.5	6.0
80	19.0	17.0	6.0
100	18.5	16.5	6.0

Promag transmitter (compact version): 3.4 kg

Promag P



Note!

The following weights apply to standard pressure ratings and without packaging material.

Nominal diameter [mm]	Weight data in [kg]								
	Compact version			Remote version (without cable)					
	EN (DIN) / AS*	JIS	Sensor		Transmitter				
EN (DIN) / AS*			JIS						
15	PN 40	6.5	10K	6.5	PN 40	4.5	10K	4.5	6.0
25		7.3		7.3		5.3		5.3	6.0
32		8.0		7.3		6.0		5.3	6.0
40		9.4		8.3		7.4		6.3	6.0
50		10.6		9.3		8.6		7.3	6.0
65	PN 16	12.0	10K	11.1	PN 16	10.0	10K	9.1	6.0
80		14.0		12.5		12.0		10.5	6.0
100		14.4		14.7		14.0		12.7	6.0
125		16.0		21.0		19.5		19.0	6.0
150		21.5		24.5		23.5		22.5	6.0
200	PN 10	45	10K	41.9	PN 10	43	10K	39.9	6.0
250		65		69.4		63		67.4	6.0
300		70		72.3		68		70.3	6.0
350		115				113			6.0
400		135				133			6.0
450	175		173		6.0				
500	175		173		6.0				
600	235		233		6.0				

Promag transmitter (compact version): 3.4 kg
 High-temperature version: +1.5 kg
 * Only DN 25 and 50 are available for flanges as per AS

Promag W



Note!

The following weights apply to standard pressure ratings and without packaging material.

Nominal diameter [mm]	Weight data in [kg]								
	Compact version			Remote version (without cable)					
	EN (DIN) / AS*		JIS	Sensor		Transmitter			
	EN (DIN) / AS*		JIS	EN (DIN) / AS*	JIS				
25	PN 40	7.3	10K	7.3	PN 40	10K	5.3	6.0	
32		8.0		7.3			6.0	5.3	6.0
40		9.4		8.3			7.4	6.3	6.0
50		10.6		9.3			8.6	7.3	6.0
65	PN 16	12.0	10K	11.1	PN 16	10K	10.0	6.0	
80		14.0		12.5			12.0	10.5	6.0
100		16.0		14.7			14.0	12.7	6.0
125		21.5		21.0			19.5	19.0	6.0
150	PN 10	25.5	10K	24.5	PN 10	10K	23.5	6.0	
200		45		41.9			43	39.9	6.0
250		65		69.4			63	67.4	6.0
300		70		72.3			68	70.3	6.0
350	PN 10	115	10K	113	PN 10	10K	113	6.0	
375		134		133			133	6.0	
400		135		133			133	6.0	
450		175		173			173	6.0	
500		175		173			173	6.0	
600		235		233			233	6.0	
700		355		353			353	6.0	
800		435		433			433	6.0	
900		575		573			573	6.0	
1000		700		698			698	6.0	
1200	PN 6	850	10K	848	PN 6	10K	848	6.0	
1400		1300		1298			1298	6.0	
1600		1700		1698			1698	6.0	
1800		2200		2198			2198	6.0	
2000	2800	2798	2798	6.0					

Promag transmitter (compact version): 3.4 kg
 *Only DN 80, 100, 150 to 400, 500 and 600 are available for flanges as per AS

Weight (US units)*Promag E (ASME)*

Nominal diameter		Weight data in lbs	
		Compact version	Remote version (without cable)
		ASME	Sensor ASME
[mm]	[inch]	Class 150	Class 150
15	½"	14.3	9.92
25	1"	16.1	11.7
40	1½"	20.7	16.3
50	2"	23.4	19.0
80	3"	30.9	26.5
100	4"	35.3	30.9
150	6"	56.2	51.8
200	8"	99.2	94.8
250	10"	165.4	161.0
300	12"	242.6	238.1
350	14"	303.0	293.5
400	16"	371.3	361.8
450	18"	422.0	412.6
500	20"	503.6	494.1
600	24"	666.8	657.3

13.2

- Transmitter: 4.0 lbs (compact version); 6.8 lbs (remote version)
- Weight data without packaging material

Promag H

Note!

The following weights apply to standard pressure ratings and without packaging material.

Nominal diameter	Weight data in [lbs]		
	Compact version	Remote version (without cable)	
[inch]		Sensor	Transmitter
1/12"	11.5	4.4	13.5
5/32"	11.5	4.4	13.5
5/16"	11.7	4.4	13.5
½"	11.9	4.2	13.5
1"	12.1	6.2	13.5
1½"	14.3	9.9	13.2
2"	19.8	15.5	13.2
3"	41.9	37.5	13.2
4"	40.8	36.5	13.2

Promag transmitter (compact version): 7.5 lbs

Promag P



Note!

The following weights apply to standard pressure ratings and without packaging material.

Nominal diameter [inch]	Weight data in [lbs]				
	Compact version		Remote version (without cable)		
	ASME/AWWA		Sensor ASME/AWWA	Transmitter	
½"	Class 150	14	Class 150	10	13
1"		16		12	13
1 ½"		21		16	13
2"		23		19	13
3"		31		26	13
4"		35		31	13
6"		56		52	13
8"		99		95	13
10"		165		161	13
12"		243		238	13
14"		386		381	13
16"		452		448	13
18"		562		558	13
20"		628		624	13
24"		893		889	13

Promag transmitter (compact version): 7.5 lbs
High-temperature version: + 3.3 lbs

Promag W



Note!

The following weights apply to standard pressure ratings and without packaging material.

Nominal diameter [inch]	Weight data in [lbs]				
	Compact version		Remote version (without cable)		
	ASME/AWWA		Sensor ASME/AWWA	Transmitter	
1"	Class 150	16	Class 150	12	13
1 ½"		21		16	13
2"		23		19	13
3"		31		26	13
4"		35		31	13
6"		56		52	13
8"		99		95	13
10"		143		161	13
12"		243		238	13
14"		386		381	13
16"		452		448	13
18"		562		558	13
20"		628		624	13
24"		893		889	13

Nominal diameter [inch]	Weight data in [lbs]						
	Compact version		Remote version (without cable)				
	ASME/AWWA		Sensor ASME/AWWA	Transmitter			
28"	Class D	882	Class D	878	13		
30"		1014		1010	13		
32"		1213		1208	13		
36"		1764		1760	13		
40"		1985		1980	13		
42"		2426		2421	13		
48"		3087		3083	13		
54"		4851		4847	13		
60"		5954		5949	13		
66"		8159		8154	13		
72"		9041		9036	13		
78"		10143		10139	13		
Promag transmitter (compact version): 7.5 lbs							

Material

Promag E

- Transmitter housing
 - Compact housing: powder-coated die-cast aluminum
 - Wall-mount housing: powder-coated die-cast aluminum
- Sensor housing
 - DN 25 to 300 (1 to 12"): powder-coated die-cast aluminum
 - DN 350 to 600 (14 to 24"): with protective lacquering
- Measuring tube
 - DN ≤ 300 (12"): stainless steel 1.4301 (304) or 1.4306 (304L) (with Al/Zn protective coating)
 - DN ≥ 350 (14"): stainless steel 1.4301 (304) or 1.4306 (304L) (with protective lacquering)
- Electrodes: 1.4435 (316, 316L), Alloy C22, Tantalum
- Flanges (with protective lacquering)
 - EN 1092-1 (DIN2501): RSt37-2 (S235JRG2); C22, Fe 410W B
 - ANSI: A105
 - JIS: RSt37-2 (S235JRG2); HII
- Seals: to DIN EN 1514-1
- Ground disks: 1.4435 (316, 316L) or Alloy C22

Promag H

- Transmitter housing:
 - Compact housing: powder-coated die-cast aluminum or stainless steel field housing (1.4301 (304))
 - Wall-mounted housing: powder-coated die-cast aluminum
 - Window material: glas or polycarbonate
- Sensor housing: stainless steel 1.4301 (304)
- Wall mounting kit: stainless steel 1.4301 (304)

- Measuring tube: stainless steel 1.4301 (304)
- Liner: PFA (USP class VI; FDA 21 CFR 177.1550: 3A)
- Electrodes:
 - Standard: 1.4435 (316, 316L)
 - Option: Alloy C22, Tantalum, Platinum
- Flange:
 - All connections stainless-steel 1.4404 (316L)
 - EN (DIN), ASME, JIS made of PVDF
 - Adhesive fitting made of PVC
- Seals
 - DN 2 to 25 (1/12 to 1"): O-ring (EPDM, Viton, Kalrez), gasket seal (EPDM*, Viton, Silicone*)
 - DN 40 to 100 (1½ to 4"): gasket seal (EPDM*, Silicone*)
 - * = USP class VI; FDA 21 CFR 177.2600: 3A
- Ground rings: 1.4435 (316, 316L) (optional: Tantalum, Alloy C22)

Promag P

- Transmitter housing:
 - Compact housing: powder-coated die-cast aluminum
 - Wall-mounted housing: powder-coated die-cast aluminum
- Sensor housing
 - DN 15 to 300 (½ to 12"): powder-coated die-cast aluminum
 - DN 350 to 2000 (14 to 84"): with protective lacquering
- Measuring tube
 - DN ≤ 300 (12"): stainless steel 1.4301 (304) or 1.4306 (304L); for flanges made of carbon steel with Al/Zn protective coating
 - DN ≥ 350 (14"): stainless steel 1.4301 (304) or 1.4306 (304L); for flanges made of carbon steel with Al/Zn protective coating
- Electrodes: 1.4435 (316, 316L), Platinum, Alloy C22, Tantalum, Titanium
- Flange
 - EN 1092-1 (DIN2501): 1.4571 (316L); RSt37-2 (S235JRG2); Alloy C22; FE 410W B (DN ≤ 300 (12") with Al/Zn protective coating; DN ≥ 350 (14") with protective lacquering)
 - ASME: A105; F316L (DN ≤ 300 (12") with Al/Zn protective coating; DN ≥ 350 (14") with protective lacquering)
 - AWWA: 1.0425 (316L)
 - JIS: RSt37-2 (S235JRG2); HII; 11.0425 (316L) (DN ≤ 300 (12") with Al/Zn protective coating; DN ≥ 350 (14") with protective lacquering)
 - AS 2129
 - DN 25 (1"): A105 or RSt37-2 (S235JRG2)
 - DN 40 (1½"): A105 or St44-2 (S275JR)
 - AS 4087: A105 or St44-2 (S275JR)
- Seals: to DIN EN 1514-1
- Ground disks: 1.4435 (316, 316L) or Alloy C22

Promag W

- Transmitter housing:
 - Compact housing: powder-coated die-cast aluminum
 - Wall-mounted housing: powder-coated die-cast aluminum
- Sensor housing
 - DN 25 to 300 (1 to 12"): powder-coated die-cast aluminum

- DN 350 to 2000 (14 to 84"): with protective lacquering
- Measuring tube
 - DN ≤ 300 (12"): stainless steel 1.4301 (304) or 1.4306 (304L)
(for flanges made of carbon steel with Al/Zn protective coating)
 - DN ≥ 350 (14"): stainless steel 1.4301 (304) or 1.4306 (304L)
(for flanges made of carbon steel with protective lacquering)
- Electrodes: 1.4435 (316, 316L) or Alloy C22, Tantalum
- Flange
 - EN 1092-1 (DIN2501): 1.4571 (316L); RSt37-2 (S235JRG2); Alloy C22; FE 410 WB
(DN ≤ 300 (12") with Al/Zn protective coating; DN ≥ 350 (14") with protective lacquering)
 - ASME: A105; F316L
(DN ≤ 300 (12") with Al/Zn protective coating; DN ≥ 350 (14") with protective lacquering)
 - AWWA: 1.0425 (316L)
 - JIS: RSt37-2 (S235JRG2); HII; 1.0425 (316L)
(DN ≤ 300 (12") with Al/Zn protective coating; DN ≥ 350 (14") with protective lacquering)
 - AS 2129
 - DN 150 to 300 (6 to 12"), DN 600 (24"): A105 or RSt37-2 (S235JRG2)
 - DN 80 to 100 (3 to 4"), 350 to 500 (14 to 20"): A105 or St44-2 (S275JR)
 - AS 4087: A105 or St44-2 (S275JR)
- Seals: to DIN EN 1514-1
- Ground disks: 1.4435 (316, 316L), Alloy C22, Titanium, Tantalum

Material load diagrams

The material load diagrams (pressure-temperature diagrams) for the process connections can be found in the separate "Technical Information" documentation, which you can download in PDF format from www.endress.com.

A list of available "Technical Information" documentation can be found in the "Documentation" →  123 section.

Fitted electrodes

Promag E

- 2 measuring electrodes for signal detection
- 1 EPD electrode for empty pipe detection
- 1 reference electrode for potential equalization

Promag H

- 2 measuring electrodes for signal detection
- 1 EPD electrode for empty pipe detection, not for DN 2 to 15 (1/12 to 1/2")

Promag P

Available as standard:

- 2 measuring electrodes for signal detection
- 1 EPD electrode for empty pipe detection
- 1 Reference electrode for potential equalization

Optionally available:

- Platinum measuring electrodes only

Promag W

Available as standard:

- 2 measuring electrodes for signal detection
- 1 EPD electrode for empty pipe detection
- 1 Reference electrode for potential equalization

Optionally available:

- Exchangeable measuring electrodes for DN 350 to 2000 (14 to 78")

Process connection*Promag E*

Flange connections:

- EN 1092-1 (DIN 2501)
 - DN ≤ 300 (12") = form A
 - DN ≥ 350 (14") = flat face
 - DN 65 PN 16 and DN 600 PN 16 only as per EN 1092-1
- ASME
- JIS

Promag H

With O-ring:

- Weld nipple DIN (EN), ISO 1127, ODT/SMS
- Flange EN (DIN), ASME, JIS
- Flange made of PVDF EN (DIN), ASME, JIS
- External thread
- Internal thread
- Hose connection
- PVC adhesive fitting

With molded seal:

- Weld nipple DIN 11850, ODT/SMS
- Clamp ISO 2852, DIN 32676, L14 AM7
- Coupling DIN 11851, DIN 11864-1, ISO 2853, SMS 1145
- Flange DIN 11864-2

Promag P/W

Flange connections:

- EN 1092-1 (DIN 2501)
 - DN ≤ 300 (12") = form A
 - DN ≥ 350 (14") = flat face
 - DN 65 PN 16 and DN 600 PN 16 exclusively according to EN 1092-1
- ASME
- AWWA (Promag W only)
- JIS
- AS

Surface roughness

All data relate to parts in contact with fluid.

- Liner → PFA: ≤ 0.4 μm (15 μin)
- Electrodes: 0.3 to 0.5 μm (12 to 20 μin)
- Process connection made of stainless-steel (Promag H): ≤ 0.8 μm (31 μin)

10.1.11 Human interface

Display elements

- Liquid crystal display: illuminated, four lines with 16 characters per line
- Custom configurations for presenting different measured values and status variables
- 3 totalizers
- At ambient temperatures below -20 °C (-4 °F), the readability of the display may be impaired.

Operating elements

- Onsite operation with three optical sensor keys ($\square/\square/\square$)
- Application-specific Quick Setup menus for straightforward commissioning

Language groups

Language groups available for operation in different countries:

- Western Europe and America (WEA):
English, German, Spanish, Italian, French, Dutch, Portuguese
- Eastern Europe/Scandinavia (EES):
English, Russian, Polish, Norwegian, Finnish, Swedish, Czech
- South and East Asia (SEA):
English, Japanese, Indonesian
- China (CN):
English, Chinese



Note!

The language group is changed in the "FieldCare" operating program.

10.1.12 Certificates and approvals

CE mark

The measuring system complies with the legal requirements of the EU directives. Endress+Hauser confirms that the device has been tested successfully by affixing the CE mark to it.

C-tick mark

The measuring system is in conformity with the EMC requirements of the "Australian Communications and Media Authority (ACMA)".

Ex approval

Information about currently available Ex versions (ATEX, FM, CSA, IECEx, NEPSI etc.) can be supplied by your Endress+Hauser Sales Center on request. All explosion protection data are given in a separate documentation which is available upon request.

Sanitary compatibility

Promag H

- 3A-approval and EHEDG-tested
- Seals: FDA-compliant (except for Kalrez seals)

Promag E/P/W

No applicable approvals or certification

Drinking water approval

Promag P

- ACS

Promag W

- WRAS BS 6920
- ACS
- NSF 61
- KTW/W270

Pressure Equipment Directive

The devices can be ordered with or without a PED approval. If a device with a PED approval is required, this must be explicitly stated in the order. For devices with nominal diameters less than or equal to DN 25 (1"), this is neither possible nor necessary.

- With the PED/G1/x (x = category) marking on the sensor nameplate, Endress+Hauser confirms compliance with the "Essential Safety Requirements" specified in Annex I of the Pressure Equipment Directive 97/23/EC.
- Devices bearing this marking (PED) are suitable for the following types of medium: Media in Group 1 and 2 with a vapor pressure greater than, or smaller and equal to 0.5 bar (7.3 psi)
- Devices not bearing this marking (PED) are designed and manufactured according to good engineering practice. They meet the requirements of Art.3 Section 3 of the Pressure Equipment Directive 97/23/EC. The range of application is indicated in tables 6 to 9 in Annex II of the Pressure Equipment Directive.

FOUNDATION Fieldbus certification

The flowmeter has passed all the test procedures implemented and has been certified and registered by the Fieldbus Foundation. The device thus meets all the requirements of the following specifications:

- Certified to FOUNDATION Fieldbus specification
- The flowmeter meets all the specifications of the FOUNDATION Fieldbus H1.
- Interoperability Test Kit (ITK), revision 5.01: The device can also be operated in conjunction with other-make certified devices.
- Physical Layer Conformance Test by Fieldbus Foundation

Other standards and guidelines

- EN 60529:
Degrees of protection by housing (IP code)
- EN 61010-1
Protection measures for electrical equipment for measurement, control, regulation and laboratory procedures
- IEC/EN 61326
"Emission in accordance with requirements for class A".
Electromagnetic compatibility (EMC requirements).
- ASME/ISA-S82.01
Safety Standard for Electrical and Electronic Test, Measuring, Controlling and related Equipment - General Requirements. Pollution degree 2, Installation Category II.
- CAN/CSA-C22.2 (No. 1010.1-92)
Safety requirements for Electrical Equipment for Measurement and Control and Laboratory Use. Pollution degree 2, Installation Category I.
- NAMUR NE 21
Electromagnetic compatibility (EMC) of industrial process and laboratory control equipment.

- NAMUR NE 43
Standardization of the signal level for the breakdown information of digital transmitters with analog output signal.
- NAMUR NE 53
Software of field devices and signal-processing devices with digital electronics.

10.1.13 Ordering information

Detailed ordering information is available from the following sources:

- In the Product Configurator on the Endress+Hauser website: www.endress.com → Select country → Instruments → Select device → Product page function: Configure this product
- From your Endress+Hauser Sales Center: www.endress.com/worldwide



Note!

Product Configurator - the tool for individual product configuration

- Up-to-the-minute configuration data
- Depending on the device: Direct input of measuring point-specific information such as measuring range or operating language
- Automatic verification of exclusion criteria
- Automatic creation of the order code and its breakdown in PDF or Excel output format
- Ability to order directly in the Endress+Hauser Online Shop

10.1.14 Accessories

Various accessories are available for the transmitter and the sensor. These can be ordered separately from Endress+Hauser →  78.



Note!

For detailed information on specific order codes, please contact the Endress+Hauser service organization.

10.1.15 Documentation

- Flow Measurement (FA00005D/06)
- Promag 53E Technical Information (TI01164D/06)
- Promag 53H Technical Information (TI00048D/06)
- Promag 53P Technical Information (TI00047D/06)
- Promag 53W Technical Information (TI00046D/06)
- Promag 53 FOUNDATION Fieldbus Description of Device Functions (BA00051D/06)
- Supplementary documentation on Ex-ratings: ATEX, FM, CSA

Index

A

Accessories	78
Adapters (installation of sensors)	16
Ambient temperature range	104
Application	4
Applicator (selection and configuration software)	79
Approvals	9

C

Cable entries	
Degree of protection	55
Technical data	103
Cable length (remote version)	19
Cable specifications	48
Cable specifications (remote version)	
Cable length, conductivity	19
Calibration factor	7
CE mark	121
CE mark (Declaration of Conformity)	9
Certificates	9
Change parameter / enter numerical values	61
CIP cleaning	105
Cleaning (exterior cleaning)	77
Cleaning using pigs, Promag H	25
Code entry (function matrix)	62
Commissioning	
"Commissioning" Quick Setup menu	72
Empty pipe and full pipe adjustment (EPD)	74
Initial operation (FF interface)	68
Commubox FXA193	64
Conductivity of fluid	107
Conductivity of the fluid	
Length of connecting cable (remote version)	19
Connection	
Remote version	44
See Electrical connection	
C-tick mark	9, 121

D

Data backup	73
Declaration of Conformity (CE mark)	9
Degree of protection	55, 105
Designated use	4
Device description files	65
Device designation	6, 100
Device functions	
See the "Description of Device Functions" manual	
Display	
Display	59
Display and operating elements	58
Local display	58
See Display	
Turning the display	37
Disposal	99
Documentation, supplementary	123
Down pipes	13

Drinking water approval	122
-------------------------------	-----

E

Electrical connection	
Degree of protection	55
Post-connection check (checklist)	56
Potential equalization	53
Terminal assignment, transmitter	52
Transmitter	49, 89
Electrode cleaning circuitry	
See the "Description of Device Functions" manual ...	14
Electrodes	
Electrode Cleaning Circuitry (ECC)	14
EPD electrode	14
Measuring electrode plane	14
Reference electrode (potential equalization)	14
Electronics boards (installing/removing)	
Field housing	92
Wall-mount housing	94
EMC (Electromagnetic compatibility)	48
Empty pipe adjustment	
See Empty Pipe Detection	
Empty pipe detection (EPD)	74
EPD electrode	14
General information	74
Environment	104
EPD	
See Empty Pipe Detection	
Error limits	
See Performance characteristics	
Error messages	
Confirming error messages	63
Process errors (application errors)	89
System errors (device errors)	84
Error types (system and process errors)	63
Ex approval	121
Exterior cleaning	77

F

F-Chip	76
FieldCare	64
Fieldcheck (tester and simulator)	79
Fitted electrodes	119
Flow rate (as a function of nominal diameter)	17
FOUNDATION Fieldbus	
Hardware write protection	66
Full pipe adjustment (EPD)	74
Function check	67
Function descriptions	
See the "Description of Device Functions" manual	
Function matrix (operation)	61
Fuse, replacing	96
FXA193	79

G

Galvanic isolation	101
Ground cable	

Promag E	20	Measuring principle	100
Promag P	26	Measuring range	100
Promag W	31	Measuring system	6, 100
Grounding	43	Measuring tube	
Grounding rings		Lining, temperature range	106
Promag H	24	Medium pressure range	108
H		Medium temperature range	106
Hardware write protection		N	
FOUNDATION Fieldbus	66	Nameplate	
Hazardous substances	99	Connections	8
High-temperature version		Sensor	7
Installation	27	Transmitter	6
Temperature ranges	27	O	
HOME position (operating mode display)	58	Operable flow range	100
I		Operating conditions	104
Incoming acceptance	10	Operating elements	58
Inlet run	15	Operation	
Input	100	Device description files	65
Installation	104	Display and operating elements	
See Installation conditions		FieldCare	64
Wall-mount housing	38	Function matrix	61
Installation conditions		Operational safety	4
Dimensions	12	Order code	
Down pipes	13	Accessories	78
Foundations, supports	16	Sensor	7
Inlet and outlet runs	15	Transmitter	6
Installing pumps	12	Outlet runs	15
Mounting location	12	Output	100
Nominal diameter and flow rate	17	Output signal	100
Orientation (vertical, horizontal)	14	P	
Partially filled pipes	12	Performance characteristics	
Vibrations	15	Maximum measured error	104
Installing the sensor		Reference operating conditions	103
Adapters	16	Pigs (cleaning)	25
Foundations (DN > 300)	16	Post-installation check (checklist)	40
High-temperature version	27	Power consumption	103
Promag E	20	Power supply	103
Promag H	23	Power supply failure	103
Promag P	26	Pressure Equipment Directive	122
Promag W	31	Pressure loss	
Insulation of pipes (installing Promag P)	27	Adapters (reducers, expanders)	16
J		General information	110
Jumpers	66	Pressure tightness	109
L		Process connection	120
Language groups	121	Process error	
Length of connecting cable (remote version)	104	Definition	63
Local display		Process error messages	89
See Display		Process errors without a message	90
M		Programming mode	
Maintenance	77	Disable	62
Material	117	Enable	62
Material load diagrams	119	Promag E	
Measured variable	100	Ground cable	20
Measuring electrodes		Installation	20
See Electrodes		Seals	20
		Tightening torques	21
		Promag H	

Cleaning using pigs	25	Standards, guidelines	122
Grounding rings	24	Storage	11
Installation	23	Storage temperature	105
Seals	23	Supply voltage	103
Weld nipple	25	Surface roughness	120
Promag P		System error	
Ground cable	26	Definition	63
High-temperature version	27	System error messages	84
Installation	26	T	
Seals	26	T-DAT	
Tightening torques	27	Save/load	73
Promag W		T-DAT (HistoROM)	
Ground cable	31	Description	76
Installation	31	Technical data at a glance	100
Seals	31	Temperature	
Tightening torques	31	Storage	105
Pumps		Temperature ranges	
Mounting location	12	Ambient temperature range	104
Q		Fluid temperature	106
Quick Setup		Tightening torques	
Commissioning	72	Promag E	21
Data backup	73	Promag P	27
R		Promag W	31
Registered trademarks	9	Transmitter	
Remote version		Electrical connection	49
Connection	44	Installing the wall-mount housing	38
Repair	99	Length of connecting cable (remote version)	19
Replacing		Turning the field housing (aluminum)	36
Device fuse	96	Turning the field housing (stainless steel)	36
Electronics boards (installing/removing)	92	Transporting the sensor	10
Exchangeable electrode	97	Troubleshooting instructions	80
Returning devices	99	V	
S		Vibration resistance	105
Safety icons	5	Vibrations	15
Safety instructions	4	Measures to prevent vibrations	15
Sanitary compatibility	121	Shock and vibration resistance	105
S-DAT (HistoROM)	76	W	
Seals	77	Wall-mount housing, installing	38
Promag E	20	Weight	
Promag H	23	(SI units)	111
Promag P	26	(US units)	115
Promag W	31	Weld nipple, Promag H	25
Seals (sensor process connection)	20, 26, 31	Wiring	
Sensor installation		See Electrical connection	
See Installing sensor		Write protection	66
Serial number	6–8		
Service interface			
Commubox FXA193	64		
Commubox FXA291	79		
Shielding	43		
Shock resistance	105		
Signal on alarm	100		
SIP cleaning	105		
Software			
Amplifier display	67		
Versions (History)	99		
Spare parts	91		

www.addresses.endress.com
