

Operating Instructions

Liquisys M CLM223/253

Transmitter for Conductivity

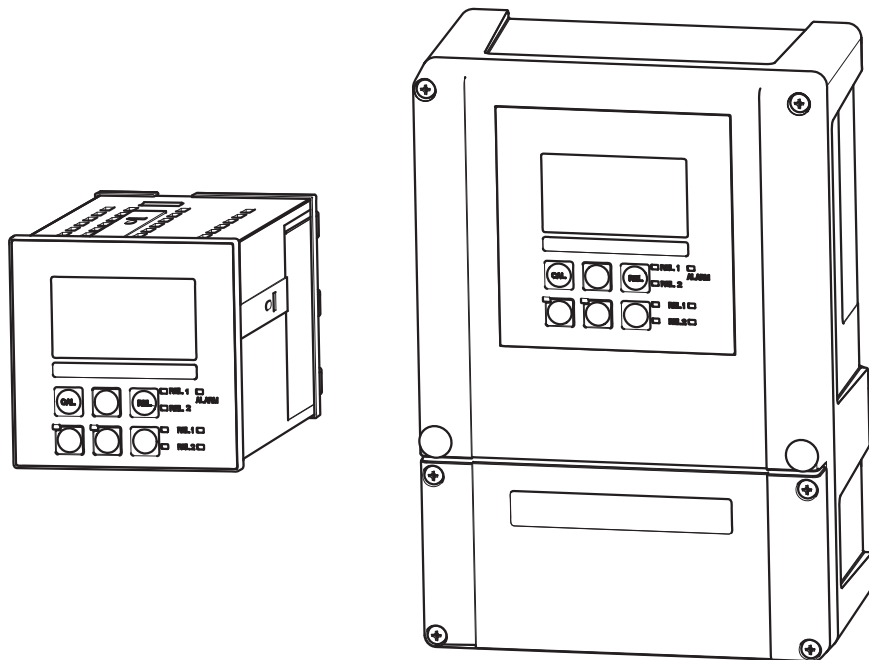

About this document

Safety messages

The structure, signal words and safety colors of the signs comply with the specifications of ANSI Z535.6 ("Product safety information in product manuals, instructions and other collateral materials").

Safety message structure	Meaning
⚠ DANGER Cause (/consequences) Consequences if safety message is not heeded ▶ Corrective action	This symbol alerts you to a dangerous situation. Failure to avoid the situation will result in a fatal or serious injury.
⚠ WARNING Cause (/consequences) Consequences if safety message is not heeded ▶ Corrective action	This symbol alerts you to a dangerous situation. Failure to avoid the situation can result in a fatal or serious injury.
⚠ CAUTION Cause (/consequences) Consequences if safety message is not heeded ▶ Corrective action	This symbol alerts you to a dangerous situation. Failure to avoid this situation can result in minor or medium injury.
NOTICE Cause/situation Consequences if safety message is not heeded ▶ Action/note	This symbol alerts you to situations that can result in damage to property and equipment.

Symbols



-  Additional information, tips
-  Permitted or recommended
-  Forbidden or not recommended

Table of contents

1	Basic safety instructions	5	6	Commissioning	30
1.1	Requirements for the personnel	5	6.1	Function check	30
1.2	Designated use	5	6.2	Switching on	30
1.3	Workplace safety	5	6.3	Quick start-up	32
1.4	Operational safety	5	6.4	System configuration	35
1.5	Product safety	6	6.4.1	Setup 1 (Conductivity)	35
1.6	Electrical symbols	6	6.4.2	Setup 2 (Temperature)	36
2	Incoming acceptance and product identification	7	6.4.3	Current input	39
2.1	Incoming acceptance	7	6.4.4	Current outputs	42
2.2	Scope of delivery	7	6.4.5	Alarm	46
2.3	Product identification	8	6.4.6	Check	47
2.3.1	Nameplate	8	6.4.7	Relay contact configuration	49
2.3.2	Identifying the product	8	6.4.8	Temperature compensation with table ..	62
2.4	Certificates and approvals	8	6.4.9	Concentration measurement	63
2.4.1	CE mark	8	6.4.10	Service	66
2.4.2	CSA general purpose	8	6.4.11	E+H Service	67
3	Mounting	9	6.4.12	Interfaces	68
3.1	Quick installation guide	9	6.5	Communication	68
3.1.1	Measuring system	9	6.6	Calibration	69
3.2	Installation conditions	10	7	Diagnostics and troubleshooting	72
3.2.1	Field instrument	10	7.1	Troubleshooting instructions	72
3.2.2	Panel-mounted instrument	11	7.2	System error messages	72
3.3	Installation instructions	12	7.3	Process specific errors	75
3.3.1	Field instrument	12	7.4	Instrument specific errors	79
3.3.2	Panel-mounted instrument	15	8	Maintenance	81
3.4	Post-installation check	15	8.1	Maintenance of the entire measuring point	81
4	Electrical connection	16	8.1.1	Cleaning the transmitter	81
4.1	Wiring	16	8.1.2	Cleaning the conductivity sensors	82
4.1.1	Connecting supply voltage	16	8.1.3	Simulation of conductive sensors for device test	82
4.1.2	Connection diagram	17	8.1.4	Simulation of inductive sensors for device test	84
4.1.3	Measuring cable and sensor connection ..	19	8.1.5	Check of conductive sensors	85
4.1.4	Alarm contact	21	8.1.6	Check of inductive sensors	85
4.2	Post-connection check	22	8.1.7	Connecting lines and junction boxes	86
5	Operability	23	9	Repair	87
5.1	Quick operation guide	23	9.1	Spare parts	87
5.2	Display and operating elements	23	9.2	Dismantling the panel-mounted instrument	87
5.2.1	Display	23	9.3	Dismantling the field instrument	90
5.2.2	Operating elements	24	9.4	Replacing the central module	93
5.2.3	Key assignment	25	9.5	Return	94
5.3	Local Operation	27	9.6	Disposal	94
5.3.1	Automatic/manual mode	27	10	Accessories	95
5.3.2	Operating concept	28	10.1	Sensors	95
			10.2	Connection accessories	96
			10.3	Mounting accessories	96
			10.4	Software and hardware add-ons	98
			10.5	Calibration solutions	98

11	Technical data.....	99
11.1	Input.....	99
11.2	Output.....	100
11.3	Power supply.....	103
11.4	Performance characteristics.....	104
11.5	Environment.....	104
11.6	Mechanical construction.....	105
12	Appendix.....	106
	Index.....	110

1 Basic safety instructions

1.1 Requirements for the personnel

- ▶ Installation, commissioning, operation and maintenance of the measuring system must only be carried out by trained technical personnel.
 - ▶ The technical personnel must be authorized by the plant operator to carry out the specified activities.
 - ▶ The electrical connection may only be performed by an electrical technician.
 - ▶ The technical personnel must have read and understood these Operating Instructions and must follow the instructions they contain.
 - ▶ Measuring point faults may only be rectified by authorized and specially trained personnel.
-  Repairs not described in the enclosed Operating Instructions may only be carried out directly at the manufacturer's or by the service organization.

1.2 Designated use

Liquisys M is a transmitter for determining the conductivity and the resistivity of a liquid medium.

The transmitter is particularly suited for use in the following areas:

- Ultrapure water
- Water treatment
- Cooling water desalinization
- Condensate treatment
- Municipal sewage treatment plants
- Chemical industry
- Food industry
- Pharmaceutical industry

Any other use than the one described here compromises the safety of persons and the entire measuring system and is, therefore, not permitted.

The manufacturer is not liable for damage caused by improper or non-designated use.

1.3 Workplace safety

As the user, you are responsible for complying with the following safety conditions:

- Regulations for explosion protection
- Installation instructions
- Local standards and regulations

Electromagnetic compatibility

With regard to electromagnetic compatibility, this device has been tested in accordance with the applicable European standards for industrial applications.

The electromagnetic compatibility indicated only applies to a device that has been connected in accordance with the instructions in these Operating Instructions.

1.4 Operational safety

- ▶ Before commissioning the entire measuring point, make sure all the connections are correct. Ensure that electrical cables and hose connections are not damaged.
- ▶ Do not operate damaged products, and safeguard them to ensure that they are not operated inadvertently. Mark the damaged product as defective.
- ▶ If faults cannot be rectified, the products must be taken out of service and secured against unintentional commissioning.

1.5 Product safety

The product is designed to meet state-of-the-art safety requirements, has been tested and left the factory in a condition in which it is safe to operate. Relevant regulations and European standards have been observed.

1.6 Electrical symbols

Safety icons



Warning!

This symbol alerts you to hazards. They can cause serious damage to the instrument or to persons if ignored.



Caution!

This symbol alerts you to possible faults which could arise from incorrect operation. They could cause damage to the instrument if ignored.



Note!

This symbol indicates important items of information.

Electrical symbols



Direct Current (DC)

A terminal at which DC is applied or through which DC flows.



Alternating Current (AC)

A terminal at which (sine-form) AC is applied or through which AC flows.



Ground connecting

A terminal which, from the user's point of view, is already grounded using a grounding system.



Protective ground terminal

A terminal which must be grounded before other connections may be set up.



Class II (isolated) device

Double insulation



Alarm relay



Input



Output



DC voltage source



Temperature sensor

2 Incoming acceptance and product identification

2.1 Incoming acceptance

- ▶ Make sure the packaging is undamaged!
- ▶ Inform the supplier about any damage to the packaging.
Keep the damaged packaging until the matter has been settled.
- ▶ Make sure the contents are undamaged!
- ▶ Inform the supplier about damage to the contents. Keep the damaged products until the matter has been settled.
- ▶ Check that the order is complete and agrees with your shipping documents.
- ▶ The packaging material used to store or to transport the product must provide shock protection and humidity protection. The original packaging offers the best protection. Also, keep to the approved ambient conditions (see "Technical data").
- ▶ If you have any questions, please contact your supplier or your local sales center.

2.2 Scope of delivery

The delivery of the field instrument includes:

- 1 transmitter CLM253
- 1 plug-in screw terminal
- 1 cable gland Pg 7
- 1 cable gland Pg 16 reduced
- 2 cable glands Pg 13.5
- 1 Operating Instructions BA00193C/07/EN
- 1 Operating Instructions
 - versions with HART communication:
 - 1 Operating Instructions Field Communication with HART, BA00208C/07/EN
 - versions with PROFIBUS communication:
 - 1 Operating Instructions Field Communication with PROFIBUS PA/DP, BA00209C/07/EN

The delivery of the panel mounted instrument includes:

- 1 transmitter CLM223
- 1 set of plug-in screw terminals
- 2 tensioning screws
- 1 Operating Instructions BA00193C/07/EN
- 1 Operating Instructions
 - versions with HART communication:
 - 1 Operating Instructions Field Communication with HART, BA00208C/07/EN
 - versions with PROFIBUS communication:
 - 1 Operating Instructions Field Communication with PROFIBUS PA/DP, BA00209C/07/EN

If you have any questions, please contact your supplier or your sales centre responsible.

2.3 Product identification

2.3.1 Nameplate

The nameplate contains the following information:

- Manufacturer data
- Order code
- Extended order code
- Serial number
- Operating conditions
- Safety icons

Compare the order code on the nameplate with your order.

2.3.2 Identifying the product

The order code and serial number of your device can be found in the following locations:

- On the nameplate
- In the delivery papers

 To find out the version of your device, enter the order code indicated on the nameplate in the search screen at the following address: www.products.endress.com/order-ident

2.4 Certificates and approvals

2.4.1 CE mark

Declaration of conformity

The product meets the requirements of the harmonized European standards. It thus complies with the legal requirements of the EC directives.

The manufacturer confirms successful testing of the product by affixing the **CE** symbol.

2.4.2 CSA general purpose

CSA General Purpose

The products listed below are eligible to bear the CSA Mark shown with adjacent indicators "C" and "US":

Version	Approval
CLM253-..2... CLM253-..3... CLM253-..7...	CSA Mark for Canada and USA
CLM223-..2... CLM223-..3... CLM223-..7...	CSA Mark for Canada and USA

3 Mounting

3.1 Quick installation guide

Proceed as follows to completely install the measuring point:

- Install the transmitter (see "Installation instructions" section).
- If the sensor is not yet installed in the measuring point, install it (see Technical Information of the sensor).
- Connect the sensor to the transmitter as illustrated in the "Electrical connection" section.
- Connect the transmitter as illustrated in the "Electrical connection" section.
- Commission the transmitter as explained in the "Commissioning" section.

3.1.1 Measuring system

A complete measuring systems comprises:

- The transmitter Liquisys M CLM223 or CLM253
- A sensor with or without an integrated temperature sensor
- A measuring cable CYK71 (conductive), CPK9 for Condumax H CLS16 or CLK5 (inductive)

Options: extension cable, junction box VBM

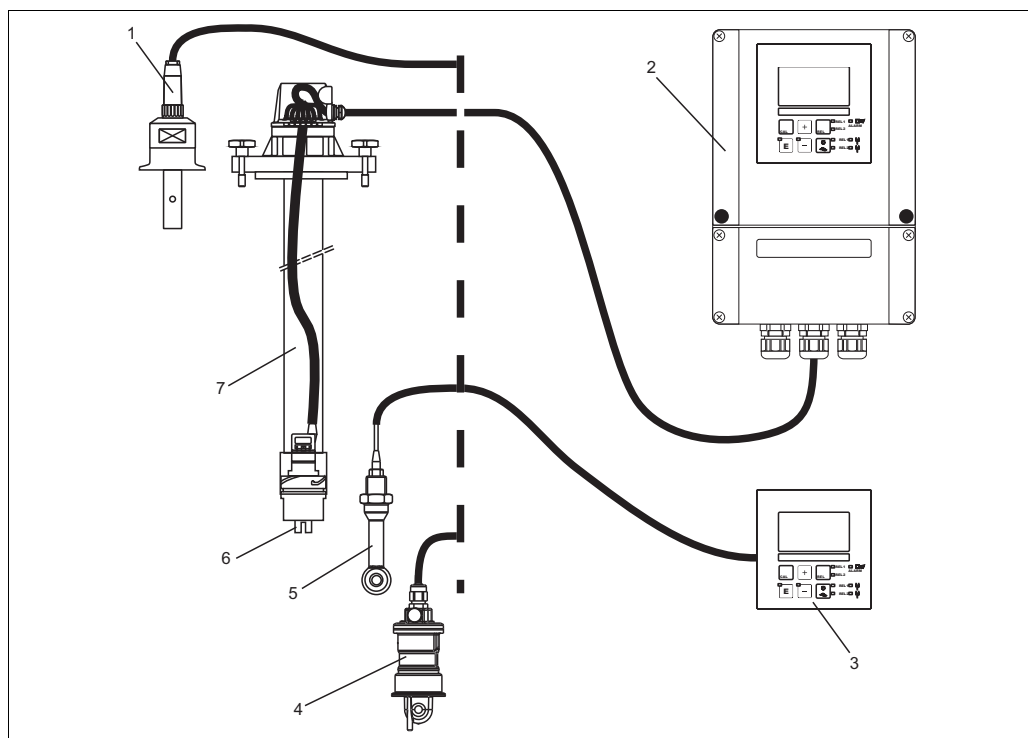

Fig. 1: Complete measuring system Liquisys M CLM223/253

- | | | | |
|---|-------------------------|---|---------------------------|
| 1 | Conductive sensor CLS15 | 5 | Inductive sensor CLS50 |
| 2 | Liquisys M CLM253 | 6 | Conductive sensor CLS21 |
| 3 | Liquisys M CLM223 | 7 | Immersion assembly CLA111 |
| 4 | Inductive sensor CLS54 | | |

3.2 Installation conditions

3.2.1 Field instrument

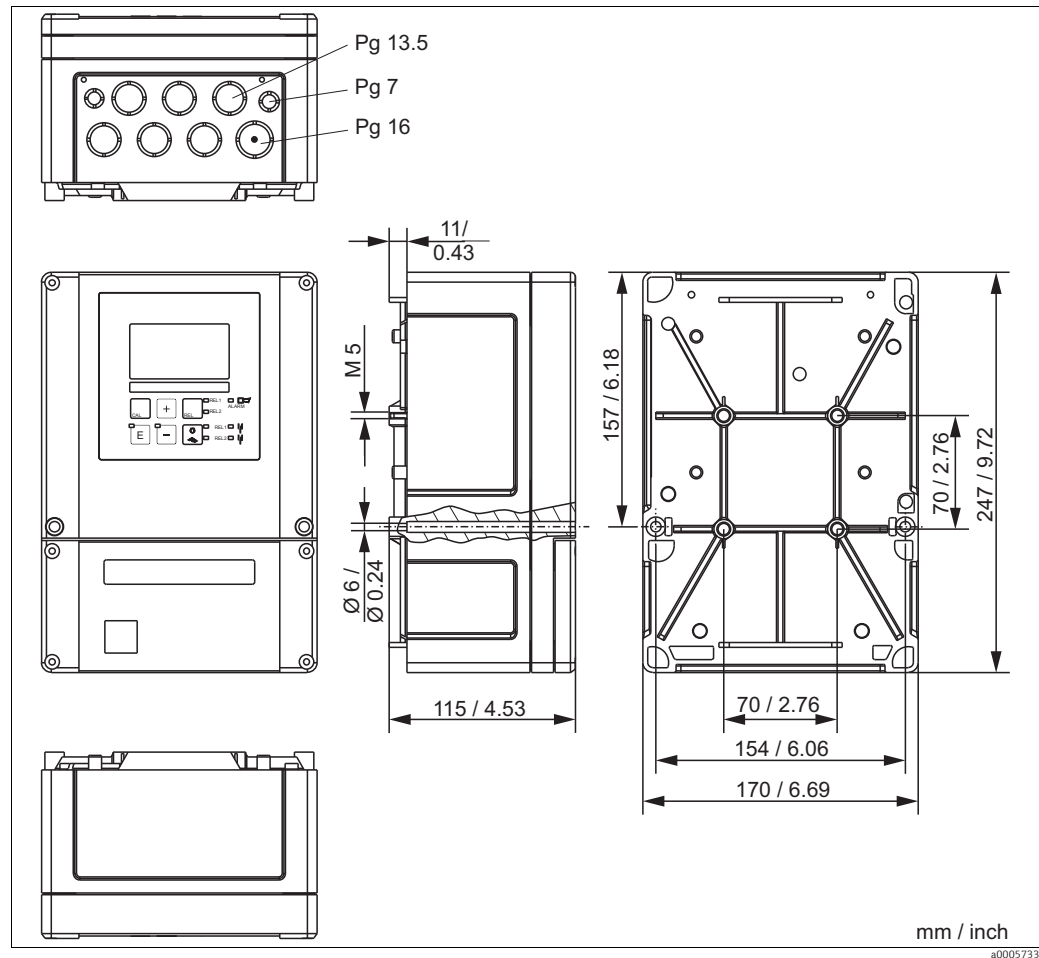

Fig. 2: Field instrument

i There is a hole in the punching for the cable entry (connection of supply voltage). It serves as a pressure balance during air freight dispatching. Make sure no moisture penetrates the inside of the housing before the cable installation. The housing is completely air-tight after the cable installation.

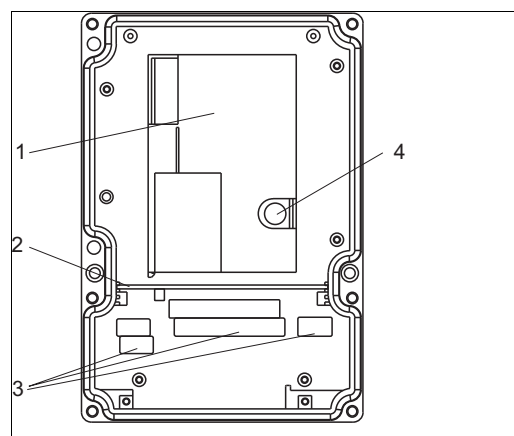

Fig. 3: View into the field housing

3.2.2 Panel-mounted instrument

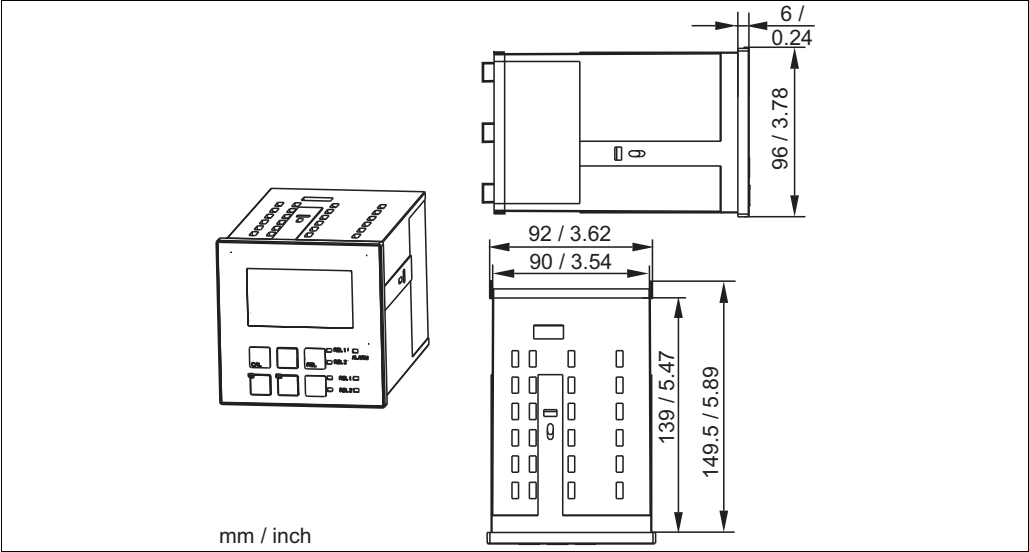

Fig. 4: Panel-mounted instrument

a0005735

3.3 Installation instructions

3.3.1 Field instrument

There are several ways of securing the field housing:

- Wall mounting with fixing screws
- Post mounting to cylindrical pipes
- Post mounting to square securing masts

NOTICE

Effect of climate conditions (rain, snow, direct sun etc.)

Impaired operation to complete transmitter failure

- ▶ When installing outside, always use the weather protection cover (accessory).

Transmitter wall mounting

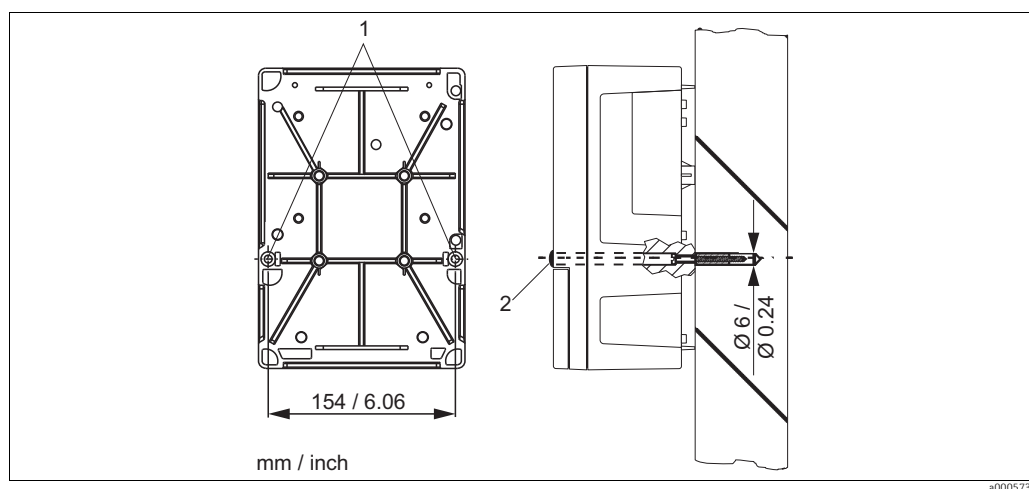

Fig. 5: Wall mounting field device

For wall mounting the transmitter, proceed as follows:

1. Drill the bores as shown in → 5.
2. Drive the two fixing screws through the securing bores (1) from the front.
3. Mount the transmitter on the wall as shown.
4. Cover the bores with plastic caps (2).

Transmitter post mounting

- i** You require a post mounting kit to secure the field device to horizontal and vertical posts or pipes (max. \varnothing 60 mm (2.36")). The kit can be acquired as an accessory (see "Accessories" section).

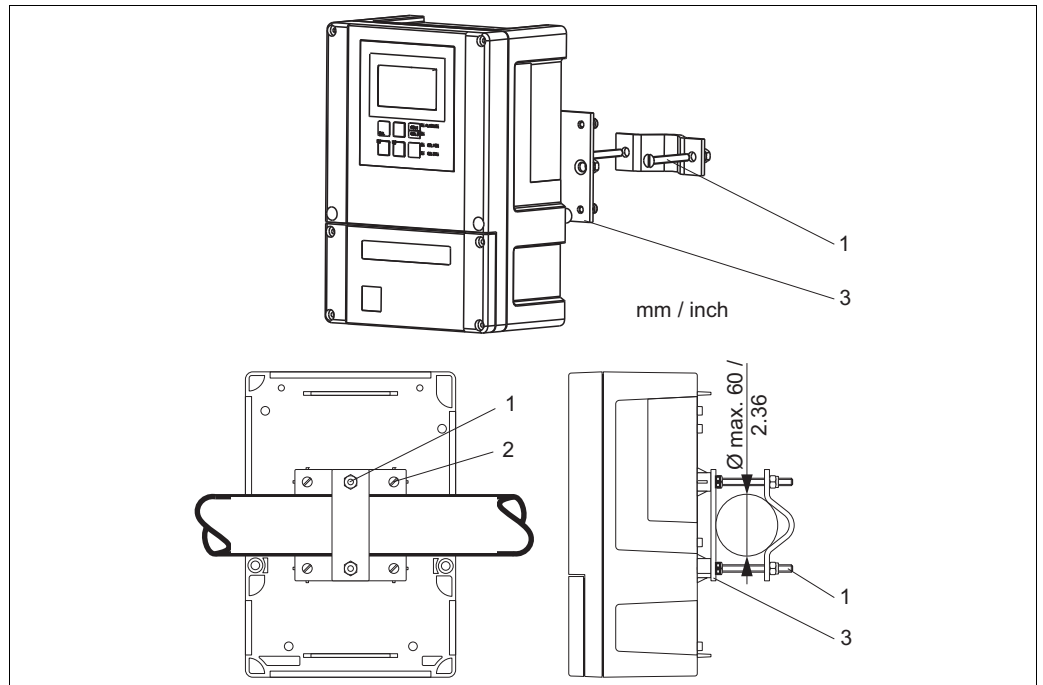

Fig. 6: Post mounting field device to cylindrical pipes

For post mounting the transmitter, proceed as follows:

1. Guide the two securing screws (1) of the mounting kit through the openings of the securing plate (3).
2. Screw the securing plate onto the transmitter using the four fixing screws (2).
3. Secure the retainer with the field device on the post or pipe using the clip.

You can also secure the field device to a square universal post in conjunction with the weather protection cover. These can be acquired as accessories, see "Accessories" section.

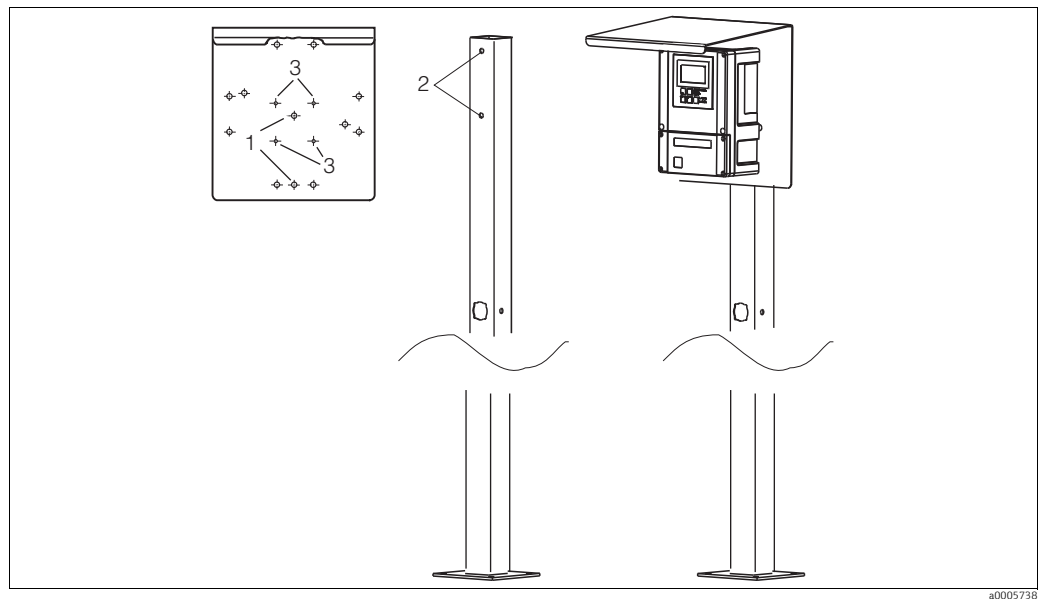



Fig. 7: Mounting field device with universal posts and weather protection cover

For mounting the weather protection cover, proceed as follows:

1. Screw the weather protection cover with 2 screws (bores 1) to the upright post (bores 2).
2. Secure the field device to the weather protection cover. To do so, use the bores (3).

3.3.2 Panel-mounted instrument

The panel-mounted instrument is secured with the clamping screws supplied (see →  8). The necessary installation depth is approx. 165 mm (6.50").

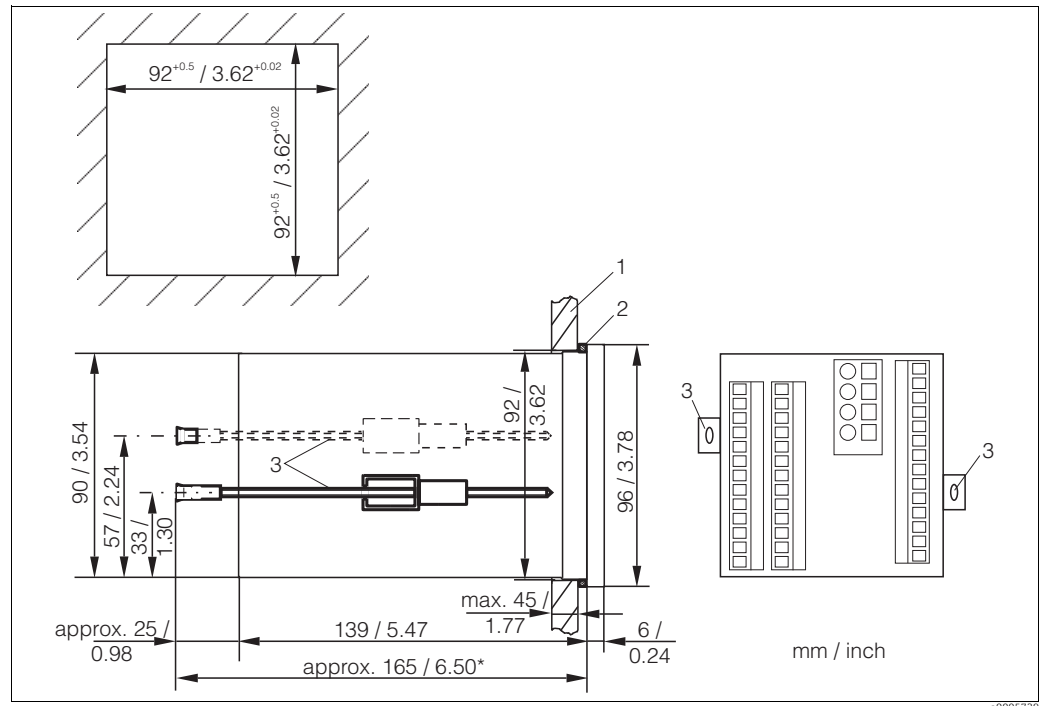

Fig. 8: Securing the panel-mounted instrument

- 1 Wall of the cabinet
- 2 Seal
- 3 Clamping screws
- * Required installation depth

3.4 Post-installation check

- After installation, check the transmitter for damage.
- Check whether the transmitter is protected against moisture and direct sunlight (e.g. by the weather protection cover).

4 Electrical connection

⚠ WARNING

Device is energized

Improper connection can cause injury or death.

- ▶ The electrical connection must only be carried out by a certified electrician.
- ▶ Technical personnel must have read and understood the instructions in this manual and must adhere to them.
- ▶ **Prior to beginning** any wiring work, make sure voltage is not applied to any of the cables.

4.1 Wiring

4.1.1 Connecting supply voltage

NOTICE

The device does not have a power switch

- ▶ You must provide a protected circuit breaker in the vicinity of the device.
- ▶ This must be a switch or a power-circuit breaker and you must label it as the circuit breaker for the device.
- ▶ At the supply point, the power supply for the 24 V versions must be isolated from dangerous live cables by double or reinforced insulation.

4.1.2 Connection diagram

The wiring diagram depicted in → 9 shows the connections of an instrument equipped with all the options. Connecting the sensors and the various measuring cables is explained in more detail in the "Measuring cables and sensor connection" section.

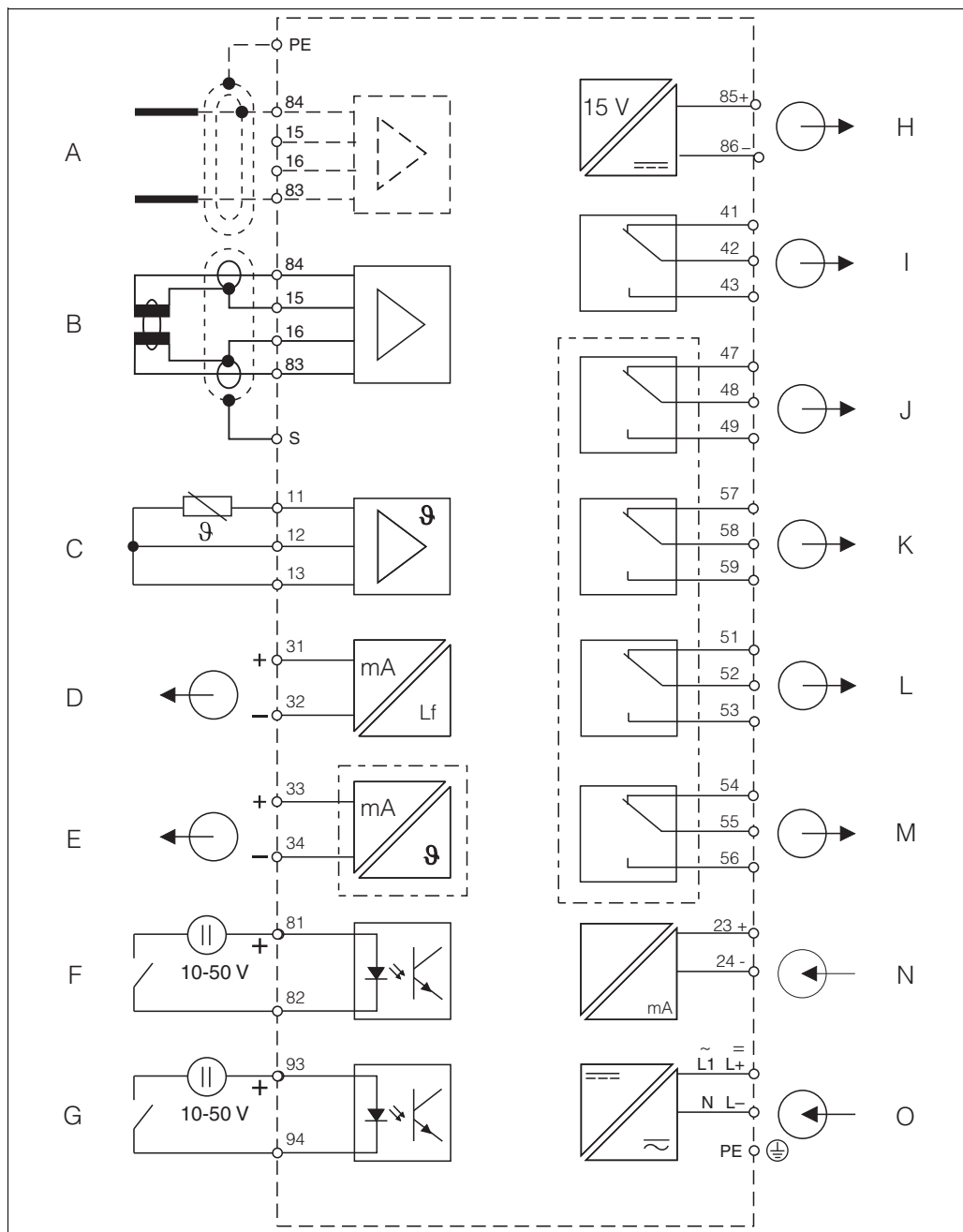

Fig. 9: Electrical connection of the transmitter

A Sensor (conductive)

B Sensor (inductive)

C Temperature sensor

D Signal output 1 conductivity

E Signal output 2 variable

F Binary input 1 (Hold)

G Binary input 2 (Chemoclean)

H Aux. voltage output

I Alarm (current-free contact position)

J Relay 1 (current-free contact position)

K Relay 2 (current-free contact position)

L Relay 3 (current-free contact position)

M Relay 4 (current-free contact position)

N Current input 4 to 20 mA

O Power supply

Pay attention to the following:

- The device is approved for protection class II and is generally operated without a protective earth connection.
- To guarantee measuring stability and functional safety, you have to ground the outer screen of the sensor cable:
 - Inductive sensors: terminal "S"
 - Conductive sensors: PE distributor rail
 This is on the cover frame for panel-mounted instruments and in the connection compartment for field devices. Ground the PE distributor rail or the ground terminal.
- The circuits "E" and "H" are not galvanically isolated from each other.

Field instrument connection

Guide the measuring cables through the PG glands into the housing. Connect the measuring cables in accordance with the terminal assignment (→  10).

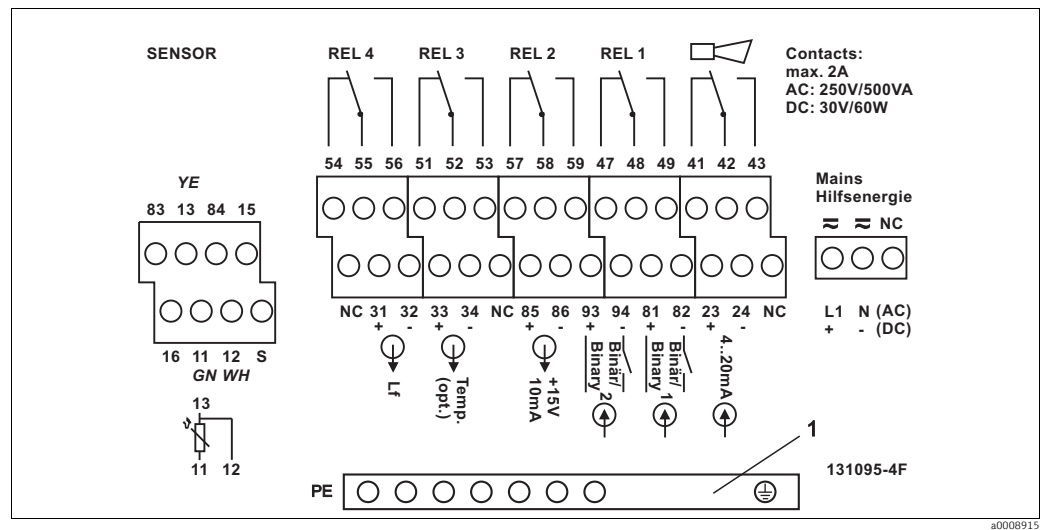

Fig. 10: Field instrument connection compartment sticker

1 PE distributor rail for CD/CS version (conductive sensors)

Panel-mounted instrument connection

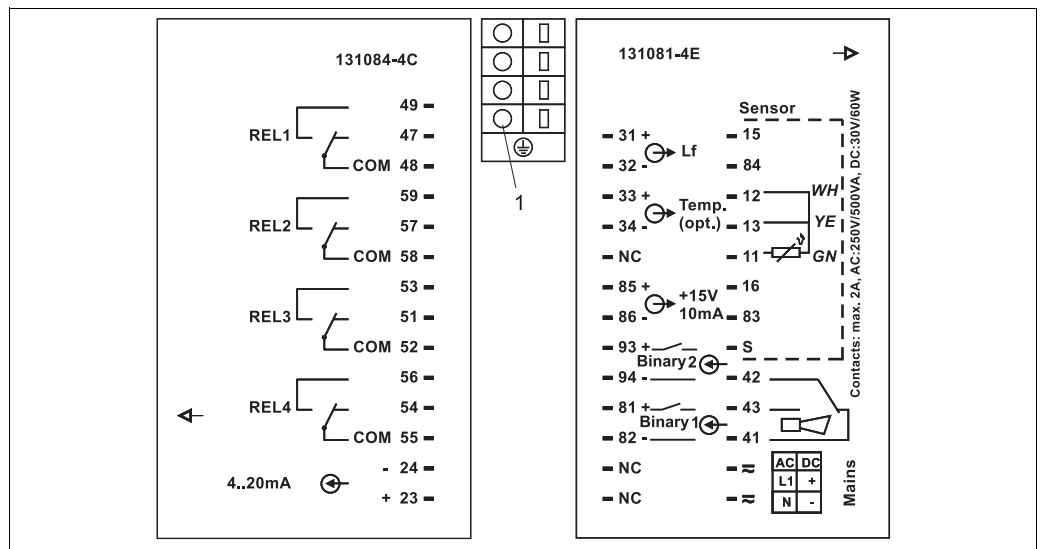

Fig. 11: Panel-mounted instrument connection sticker

1 Ground terminal

NOTICE

Nonobservance could cause incorrect measurement

- ▶ Terminals marked NC may not be wired.
- ▶ Unmarked terminals may not be wired.

i Please label the sensor terminal block with the sticker provided.

4.1.3 Measuring cable and sensor connection

You require screened special measuring cables to connect conductivity sensors to the transmitter. The following multi-core and ready-to-use cable types can be used:

Sensor type	Cable	Extension
Two-electrode sensors with or without temperature sensor Pt 100	CYK71 CPK9* (for CLS16)	Junction box VBM + CYK71
Inductive sensors CLS50, CLS52	Cable permanently attached to sensor	Junction box VBM + CLK5

* High-temperature version without PML

Maximum cable length	
Conductivity measurement (conductive)	max. 100 m (328 ft) with CYK71
Resistivity measurement	max 15 m (49.22 ft) with CYK71
Conductivity measurement (inductive)	max. 55 m (180.46 ft) with CLK5 (sensor cable incl.)

Structure and termination of the measuring cables

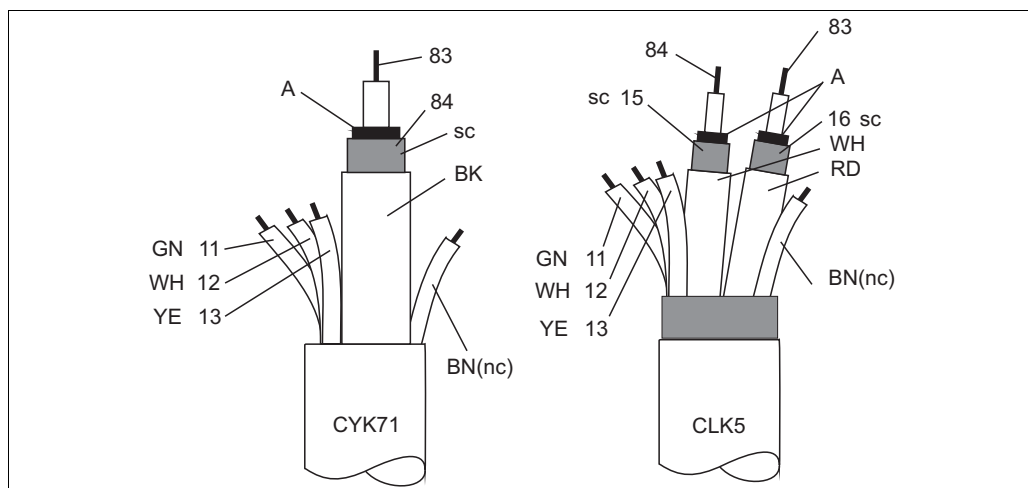

Fig. 12: Structure of the special measuring cables

A Semiconductor layer
sc Screening

i For further information on the cables and junction boxes, please refer to the "Accessories" section.

Field instrument measuring cable connection

Proceed as follows to connect a conductivity sensor to the field instrument:

1. Open the housing cover to access the terminal block in the connection compartment.
2. Break the punching of a cable gland from the housing, mount a cable gland and guide the cable through this cable gland.
3. Connect the cable in accordance with the terminal assignment (see connection compartment sticker).
4. Tighten the cable gland.

Panel-mounted instrument measuring cable connection

To connect a conductivity sensor, connect the measuring cable in accordance with the terminal assignment to the terminals on the rear of the device (see connection sticker).

Example of connecting a conductivity sensor

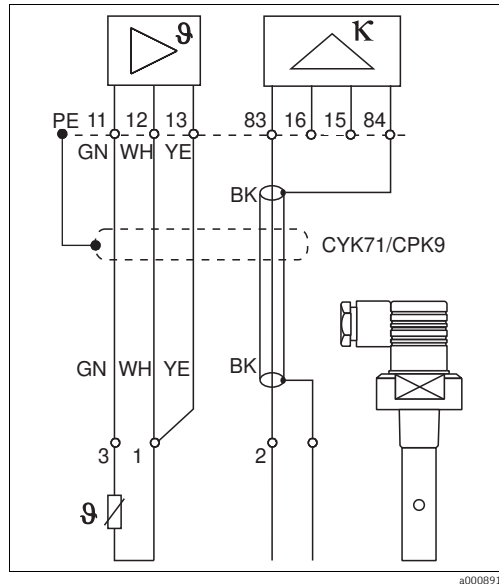

Fig. 13: Connection of conductive sensors

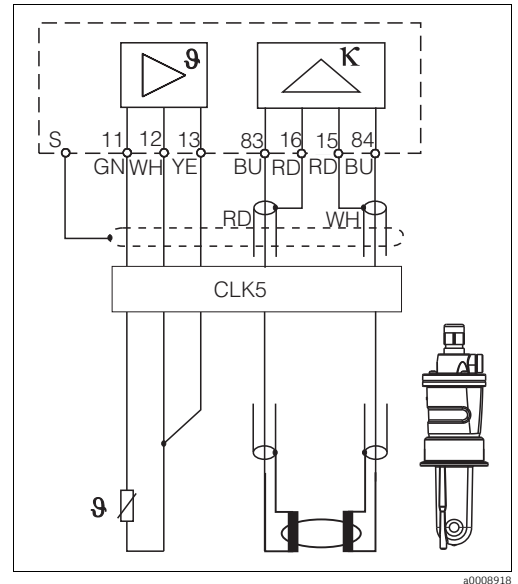

Fig. 14: Connection of inductive sensors

4.1.4 Alarm contact

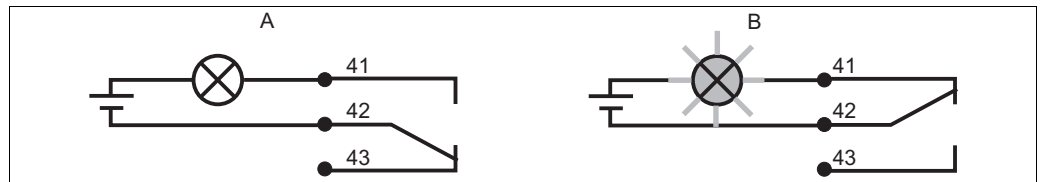

Fig. 15: Recommended fail-safe switching for the alarm contact

A Normal operating status

B Alarm condition

Normal operating status:

Device in operation and no error message present (alarm LED off)

- Relay energized
- Contact 42/43 closed

Alarm condition

Error message present (alarm LED red) or device defective or voltage-free (alarm LED off)

- Relay de-energized
- Contact 41/42 closed

4.2 Post-connection check

After wiring up the electrical connection, carry out the following checks:

Device status and specifications	Remarks
Are the transmitter or the cable externally damaged?	Visual inspection

Electrical connection	Remarks
Are the installed cables strain-relieved?	
No loops and cross-overs in the cable run?	
Are the signal cables correctly connected acc. to the wiring diagram?	
Are all screw terminals tightened?	
Are all cable entries installed, tightened and sealed?	
Are the PE distributor rails grounded (if present)?	Grounding at place of installation

5 Operability

5.1 Quick operation guide

You have the following ways of operating the transmitter:

- On site via the key field
- Via the HART interface (optional, with corresponding order version) per:
 - HART handheld terminal or
 - PC with HART modem and the FieldCare software package
- Via PROFIBUS PA/DP (optional, with corresponding order version) with:
 - PC with corresponding interface and the FieldCare software package (see Accessories) or
 - via a programmable logic controller (PLC)

 For operation via HART or PROFIBUS PA/DP, please read the relevant sections in the additional Operating Instructions:





- PROFIBUS PA/DP, field communication for Liquisys M CXM223/253, BA00209C/07/EN
- HART, field communication for Liquisys M CXM223/253, BA00208C/07/EN

The following section only explains operation via the keys.

5.2 Display and operating elements

5.2.1 Display

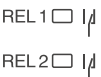
LED display

	Indicates the current operating mode, "Auto" (green LED) or "Manual" (yellow LED)
	Indicates the activated relay in the "Manual" mode (red LED)
	Indicates the working status of relay 1 and 2 LED green: measured value within the permitted limit, relay inactive LED red: measured value outside the permitted limit, relay active
	Alarm display, e.g. for continuous limit value overshoot, temperature sensor failure or system error (see error list)

LC display

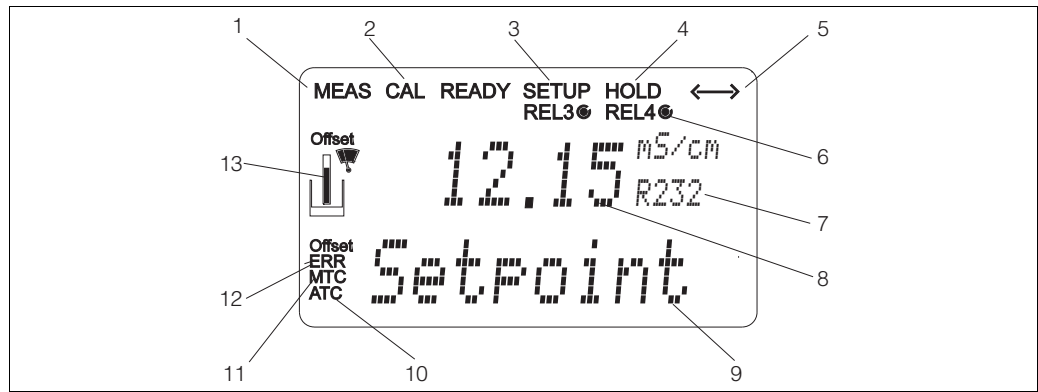

Fig. 16: LC display transmitter

- | | | | |
|---|--|----|--|
| 1 | Indicator for measuring mode (normal operation) | 8 | In measuring mode: measured variable
In setup mode: configured variable |
| 2 | Indicator for calibration mode | 9 | In measuring mode: secondary measured value
In setup/calibr. mode: e.g. setting value |
| 3 | Indicator for setup mode (configuration) | 10 | Indicator for autom. temperature compensation |
| 4 | Indicator for "Hold" mode (current outputs remain at last current state) | 11 | Indicator for man. temperature compensation |
| 5 | Indicator for receipt of a message for devices with communication | 12 | "Error": error display |
| 6 | Indicator of working status of relays 3/4:
○ inactive, ● active | 13 | Sensor symbol |
| 7 | Function code display | | |

5.2.2 Operating elements

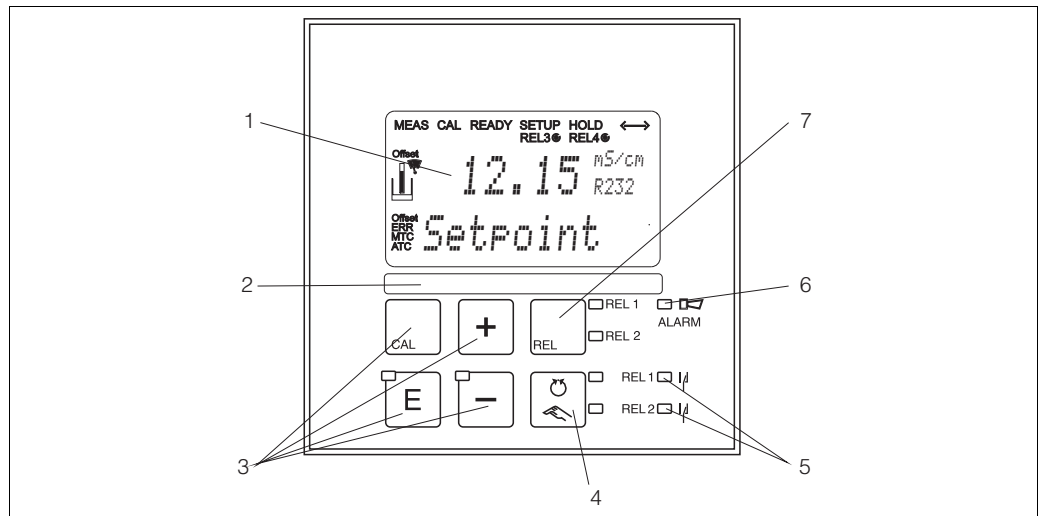







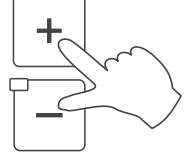
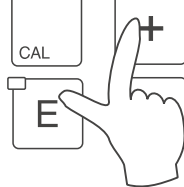
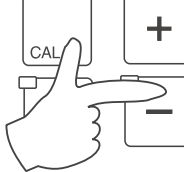

Fig. 17: Operating elements

- | | |
|---|---|
| 1 | LC display for displaying the measured values and configuration data |
| 2 | Field for user labelling |
| 3 | 4 main operating keys for calibration and device configuration |
| 4 | Changeover switch for automatic/manual mode of the relays |
| 5 | LEDs for limit contactor relay (switch status) |
| 6 | LED for alarm function |
| 7 | Display of the active contact and key for relay changeover in manual mode |

5.2.3 Key assignment

	<p>CAL key When you press the CAL key, the device first prompts you for the calibration access code:</p> <ul style="list-style-type: none"> ▪ Code 22 for calibration ▪ Code 0 or any other code for reading the last calibration data <p>Use the CAL key to accept the calibration data or to switch from field to field within the calibration menu.</p>
	<p>ENTER key When you press the ENTER key, the device first prompts you for the setup mode access code:</p> <ul style="list-style-type: none"> ▪ Code 22 for setup and configuration ▪ Code 0 or any other code for reading all configuration data. <p>The ENTER key has several functions:</p> <ul style="list-style-type: none"> ▪ Calls up the Setup menu from the measuring mode. ▪ Saves (confirms) data entered in the setup mode. ▪ Moves on within function groups.
 	<p>PLUS key and MINUS key In the setup mode, the PLUS and MINUS keys have the following functions:</p> <ul style="list-style-type: none"> ▪ Selection of function groups. <ul style="list-style-type: none">  Press the MINUS key to select the function groups in the order given in the "System configuration" section. ▪ Configuration of parameters and numerical values ▪ Operation of the relay in manual mode <p>In the measuring mode, you get the following sequence of functions by repeatedly pressing the PLUS key:</p> <ol style="list-style-type: none"> 1. Temperature display in F 2. Temperature display hidden 3. Current input signal in % 4. Current input signal in mA 5. Display of the uncompensated conductivity 6. Return to basic settings <p>In the measuring mode, the following is displayed in sequence by repeatedly pressing the MINUS key:</p> <ol style="list-style-type: none"> 1. Current errors are displayed in rotation (max. 10). 2. Once all the errors have been displayed, the standard measurement display appears. In the function group F, an alarm can be defined separately for each error code.
 <ul style="list-style-type: none"> <input type="checkbox"/> REL 1 <input type="checkbox"/> REL 2 	<p>REL key In the manual mode, you can use the REL key to switch between the relay and the manual start of cleaning. In the automatic mode, you can use the REL key to read out the switch-on points (for limit contactor) or set points (for PID controller) assigned to the relay in question. Press the PLUS key to jump to the settings of the next relay. Use the REL key to get back to the display mode (automatic return after 30 s).</p>





	<p>AUTO key You can use the AUTO key to switch between automatic mode and manual mode.</p>
	<p>Escape function If you press the PLUS and MINUS key simultaneously, you return to the main menu or are taken to the end of calibration if calibrating. If you press the PLUS and MINUS key again, you return to the measuring mode.</p>
	<p>Locking the keyboard Press the PLUS and ENTER key for at least 3 s to lock the keyboard against any unauthorized data entry. All the settings can continue to be read. The code prompt displays the code 9999.</p>
	<p>Unlocking the keyboard Press the CAL and MINUS key for at least 3 s to unlock the keyboard. The code prompt displays the code 0.</p>

5.3 Local Operation

5.3.1 Automatic/manual mode

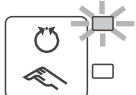
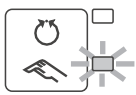
The transmitter normally operates in automatic mode. Here, the relays are triggered by the transmitter. In the manual mode, you can trigger the relays using the REL key or start the cleaning function.

How to change the operating mode:

	<p>1. The transmitter is in Automatic mode. The top LED beside the AUTO key is lit.</p>
	<p>2. Press the AUTO key.</p>
	<p>3. To enable the manual mode, enter the code 22 via the PLUS and MINUS keys. The bottom LED beside the AUTO key lights up.</p>
	<p>4. Select the relay or the function. You can use the REL key to switch between the relays. The relay selected and the switch status (ON/OFF) is displayed on the second line of the display. In the manual mode, the measured value is displayed continuously (e.g. for measured value monitoring for dosing functions).</p>
	<p>5. Switch the relay. It is switched on with PLUS and switched off with MINUS. The relay remains in its switched state until it is switched over again.</p>
	<p>6. Press the AUTO key to return to the measuring mode, i.e. to the automatic mode. All the relays are triggered again by the transmitter.</p>

Pay attention to the following:

- The selected operating mode remains in effect even after a power failure.
- The manual mode has priority over all automatic functions (Hold).
- Hardware locking is not possible in the manual mode.
- The manual settings are kept until they are actively reset.
- Error code E102 is signalled in the manual mode.

5.3.2 Operating concept

Operating modes

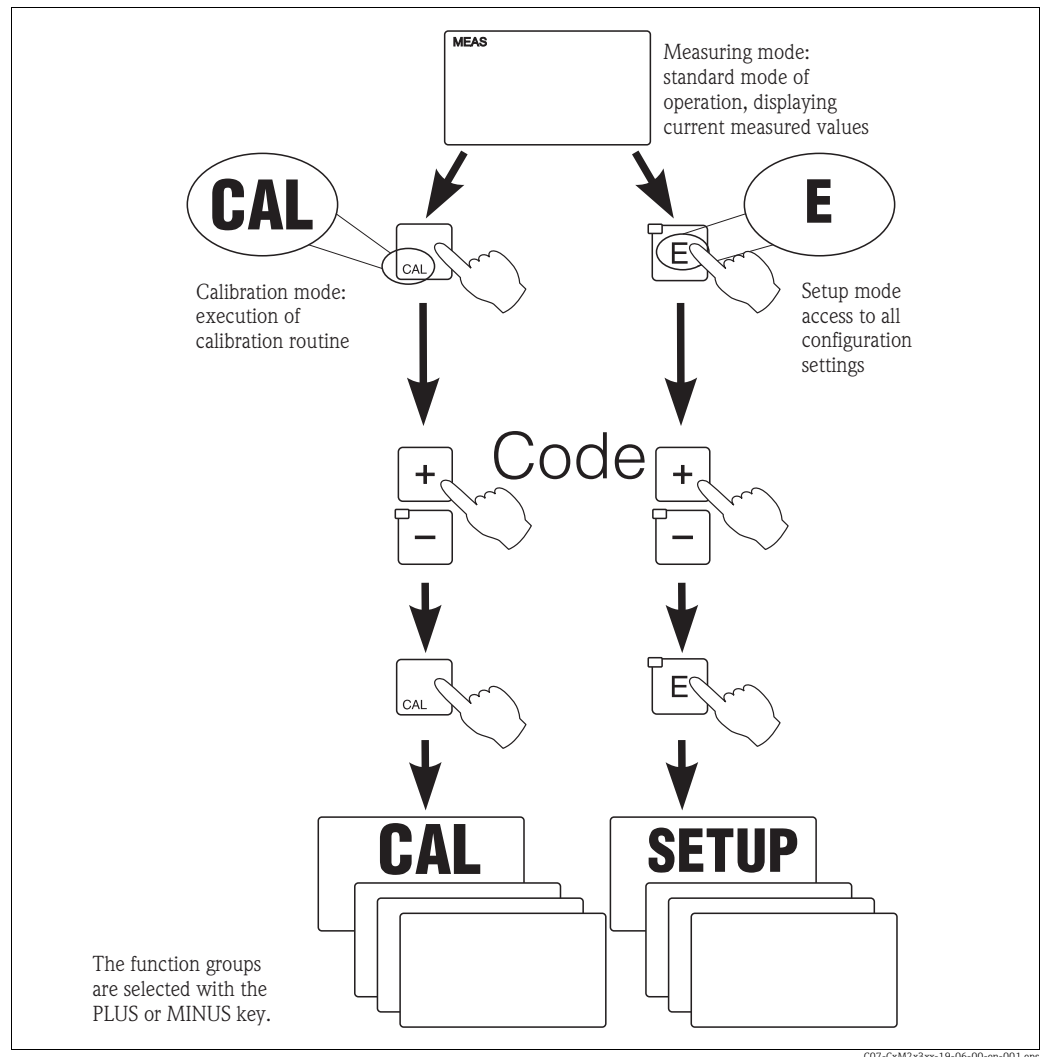

Fig. 18: Description of the possible operating modes

- i** If no key is pressed in the setup mode for approx. 15 min, the device automatically returns to the measuring mode. Any active Hold (Hold during setup) is reset.

Access codes

All device access codes are fixed and cannot be altered. When the device requests the access code, it distinguishes between different codes.

- **Key CAL + Code 22:** access to Calibration and Offset menu
- **Key ENTER + Code 22:** access to the setup menus
- **Keys PLUS + ENTER:** locks the keyboard
- **Keys CAL + MINUS:** unlocks the keyboard
- **Key CAL or ENTER + any code:** access to read mode, i.e. all the settings can be read but not modified.

The device continues measuring in the read mode. It does not shift to the Hold status. The current output and the controllers remain active.

Menu structure

The configuration and calibration functions are arranged in function groups.

- In setup mode, select a function group with the PLUS and MINUS keys.
 - In the function group itself, switch from function to function with the ENTER key.
 - Within the function, select the desired option with the PLUS and MINUS keys or edit the settings with these keys. Then confirm with the ENTER key and continue.
 - Press the PLUS and MINUS keys simultaneously (Escape function) to exit programming (return to the main menu).
 - Press the PLUS and MINUS simultaneously keys again to switch to the measuring mode.
- i** If a modified setting is not confirmed with ENTER, the old setting is retained.
An overview of the menu structure is provided in the Appendix to these Operating Instructions.

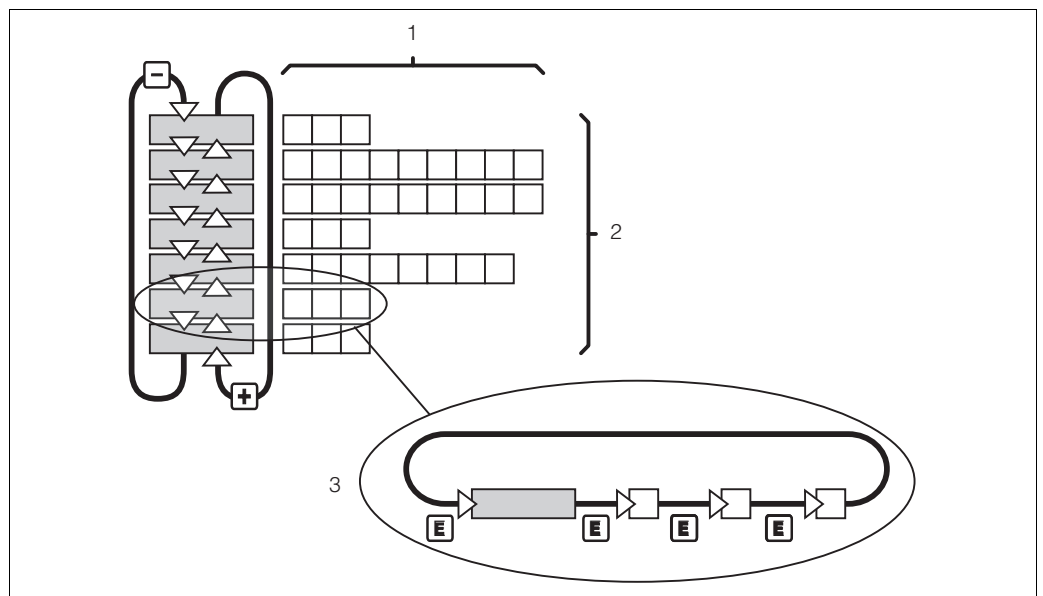

Fig. 19: Diagram of the menu structure

- 1 Functions (parameters selected, numbers entered)
- 2 Function groups, scroll backwards and forwards with the PLUS and MINUS keys
- 3 Switch from function to function with the ENTER key

Hold function: "freezing" of the outputs

During setup and calibration, the current output can be "frozen". It constantly retains its current status. "HOLD" appears on the display. If the controller actuating variable (steady control 4 to 20 mA) is output via current output 2, it is set to 0/4 mA in Hold.

Pay attention to the following:

- Hold settings can be found in the "Service" section.
- During Hold, all contacts will go to their normal positions.
- An active Hold has priority over all other functions.
- With every Hold, the I-component of the controller is set to zero.
- Any alarm delay is reset to "0".
- This function can also be activated externally via the Hold input (see Wiring diagram; binary input 1).
- The manual Hold (field S3) remains active even after a power failure.

6 Commissioning

6.1 Function check

⚠ WARNING

Incorrect connection, incorrect supply voltage

Safety risks for staff and incorrect operation of the device

- ▶ Check that all connections have been established correctly in accordance with the wiring diagram.
- ▶ Make sure that the supply voltage matches the voltage indicated on the nameplate.

6.2 Switching on

Familiarize yourself with the operation of the transmitter before it is first switched on. Please refer in particular to the "Safety instructions" and "Operation" sections. After power-up, the device performs a self-test and then goes to the measuring mode. Now calibrate the sensor in accordance with the instructions in the "Calibration" section.

i During commissioning, the sensor must be calibrated so that the measuring system can return precise measurement data.

Then perform the first configuration in accordance with the instructions in the "Quick start-up" section. The values set by the user are kept even in the event of a power failure.

The following function groups are available in the transmitter (the groups only available in the Plus Package are marked accordingly in the functional description):

Setup mode

- SETUP 1 (A)
- SETUP 2 (B)
- CURRENT INPUT (Z)
- CURRENT OUTPUT (O)
- ALARM (F)
- CHECK (P)
- RELAY (R)
- TEMPERATURE COMPENSATION (T)
- CONCENTRATION MEASUREMENT (K)
- SERVICE (S)
- E+H SERVICE (E)
- INTERFACE (I)

Calibration mode

- CALIBRATION (C)

i A detailed explanation of the function groups available in the transmitter can be found in the "System configuration" section.

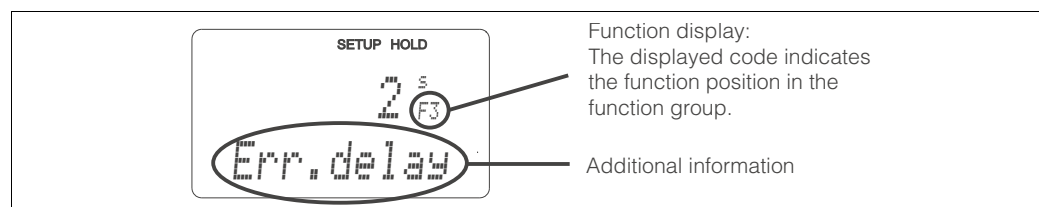

C07-CLD132xx-07-06-00-en-003.eps

Fig. 20: Example for display in setup mode

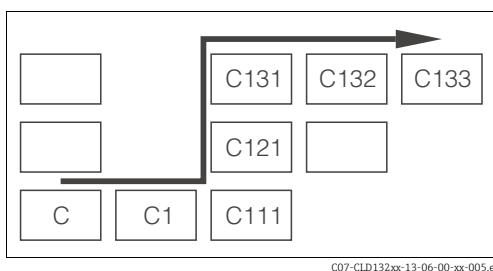

Fig. 21: Function coding

Selecting and locating functions is facilitated by a code displayed for each function in a special display field → 20.

The structure of this coding is given in → 21.

The first column indicates the function group as a letter (see group designations). The functions in the individual groups are counted from the top to the bottom and from the left to the right.

Factory settings

The first time it is switched on, the device has the factory setting for all functions. The table below provides an overview of the most important settings.

All other factory settings can be found in the description of the individual function groups in the "System configuration" section (the factory setting is highlighted in **bold**).

Function	Factory setting
Type of measurement	Conductive conductivity measurement Temperature measurement in °C
Type of measurement compensation	Linear with reference temperature 25 C (77 °F)
Temperature compensation	Automatic (ATC on)
Limit value for controller 1	9999 mS/cm
Limit value for controller 2	9999 mS/cm
Hold	Active during configuration and calibration
Measuring range	0 µS/cm to 2000 mS/cm (no measuring ranges for setting). The setting is flowing and is guided by the connected sensors.
Current outputs 1* and 2*	4 to 20 mA
Current output 1: measured value for 4 mA signal current*	0 µS/cm
Current output 1: measured value for 20 mA signal current*	2000 mS/cm
Current output 2: temperature value for 4 mA signal current*	-35.0 C (-31 °F)
Current output 2: temperature value for 20 mA signal current*	250.0 C (482 °F)

* For corresponding version

6.3 Quick start-up

After power-up, you must make some settings to configure the most important functions of the transmitter which are required for correct measurement. The following section gives an example of this.

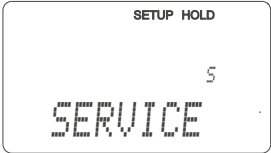
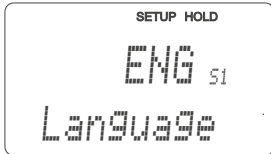
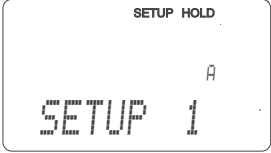
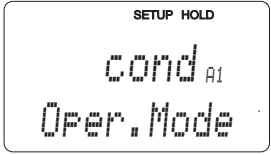
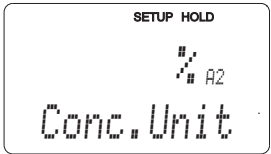
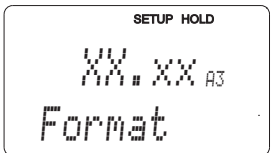
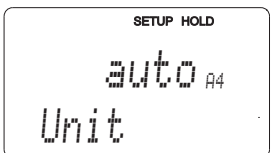
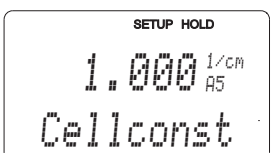
User input	Setting range (Factory settings, bold)	Display
1. Press the E key. 2. Enter the code 22 to edit the setup. Press E .		
3. Press - until you get to the "Service" function group. 4. Press E to be able to make your settings.		
5. In S1, select your language, e.g. "ENG" for English. Press E to confirm.	ENG = English GER = German FRA = French ITA = Italian NEL = Dutch ESP = Spanish	
6. Press +/- simultaneously to exit the "Service" function group.		
7. Press - until you get to the "Setup 1" function group. 8. Press E to be able to make your settings for "Setup 1".		
9. In A1, select the desired mode of operation, e.g. "cond" = conductive. Press E to confirm.	cond = conductive ind = inductive MOhm = resistivity conc = concentration	
10. In A2, press E to confirm the factory settings. (if A1 = conc, else step 12)	% ppm mg/l TDS = Total Dissolved Solids none	
11. In A3, press E to confirm the factory settings.	XX.xx X.xxx XXX.x XXXX	
12. In A4, press E to confirm the factory settings.	auto , $\mu\text{S}/\text{cm}$, mS/cm , S/cm , $\mu\text{S}/\text{m}$, mS/m , S/m	
13. In A5, enter the cell constant of the connected sensor. Refer to the sensor's quality certificate for the exact value.	cond: 1.000 cm^{-1} ind: 1.98 cm^{-1} MOhm: 0.01 cm^{-1} 0.0025 to 99.99 cm^{-1}	

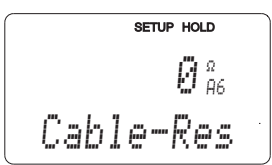
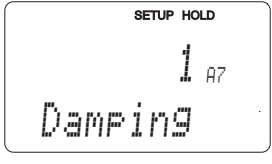
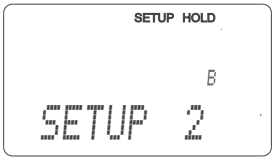
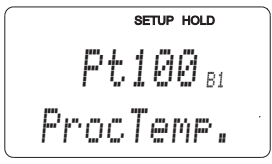
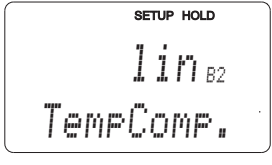
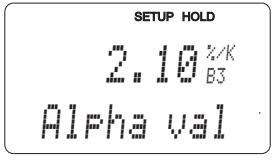
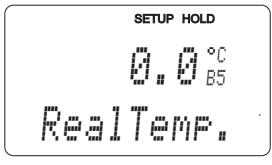
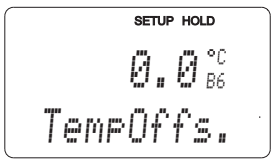
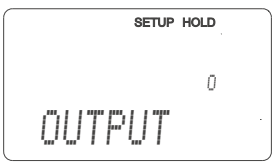
User input	Setting range (Factory settings, bold)	Display
14. In A6, enter the resistance of the cable (conductive sensors only).	0 Ω 0 to 99.99 Ω	
15. If you need to stabilize the display, enter the required damping factor in A7. Press E to confirm. The display returns to the initial display of "Setup 1"	1 1 to 60	
16. Press - to go to the "Setup 2" function group 17. Press E to edit "Setup 2"		
18. In B1, select your temperature sensor. Press E to confirm.	Pt 100 Pt 1k = Pt 1000 NTC30 fixed	
19. In B2, select the appropriate temperature compensation for your process, e.g. "lin" = linear. Press E to confirm your selection. For detailed information on temperature compensation, see chapter "Setup 2"	none lin = linear NaCl = common salt (IEC 60746) Pure = ultra pure water NaCl PureH = ultra pure water HCl Tab = table	
20. In B3, enter the temperature coefficient α. Press E to confirm.	2.1 %/K 0.0 ... 20.0 %/K	
21. The real temperature is displayed in B5. If necessary, calibrate the temperature sensor to an external measurement. Press E to confirm.	Display and entry of real temperature -35.0 to 250.0 °C fixed	
22. The difference between the measured and the entered temperatures is displayed. Press E . The display returns to the initial display of the "Setup 2" function group.	0.0 °C -5.0 to 5.0 °C	
23. Press - to go to the "Current output" function group. 24. Press E to edit the output settings.		



User input	Setting range (Factory settings, bold)	Display
25. In O1, select your output, e.g. "Out1" = output 1. Press E to confirm.	Out1 Out2	
26. In O3, select the linear characteristic. Press E to confirm.	lin = linear (1) sim = simulation Tab = table	
27. In O311, select the current range for your output, e.g. 4 to 20 mA. Press E to confirm.	4 to 20 mA 0 to 20 mA	
28. In O312, enter the conductivity corresponding to the minimum current value at the transmitter output, e.g. 0 µS/cm. Press E to confirm.	cond/ind: 0.00 µS/cm MOhm: 0.00 kΩ·cm Conc: 0.00 % Temp: 0.00 °C	
29. In O313, enter the conductivity corresponding to the maximum current value at the transmitter output, e.g. 2000 mS/cm. Press E to confirm. The display returns to the initial display of the "Current output" function group.	cond/ind: 2000 mS/cm MOhm: 500 kΩ·cm Conc: 99.99 % Temp: 150 °C	
30. Press + simultaneously to switch to the measurement mode.		

i For inductive sensors you must perform an airset before installation of the sensor, refer to the chapter "Calibration"

6.4 System configuration

6.4.1 Setup 1 (Conductivity)

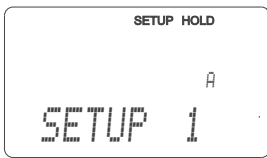
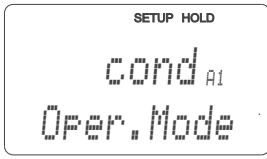
In the SETUP 1 function group, you can change the operating mode and the sensor settings. Basic version does not include functions in *italic*.

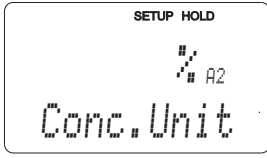
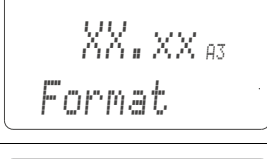
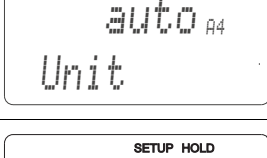
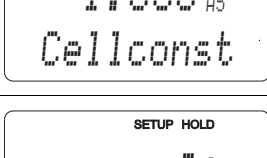
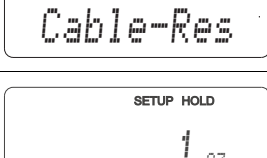
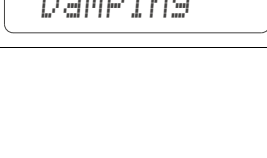
Coding	Field	Selection or range (factory settings bold)	Display	Info
A	Function group SETUP 1			Basic settings.
A1	Select operating mode	cond = conductive ind = inductive MΩm = resistivity <i>conc</i> = concentration		Display varies depending on instrument version: – cond/resistivity/conc – ind/conc  Any change in operating mode causes an automatic reset of user settings.
A2	Select concentration unit to be displayed (only with Plus Package)	% <i>ppm</i> <i>mg/l</i> TDS = Total Dissolved Solids <i>none</i>		A2 only active if A1 = conc.
A3	Select display format for concentration unit (only with Plus Package)	XX.xx <i>X.xxx</i> <i>XXX.x</i> <i>XXXX</i>		A3 only active if A1 = conc.
A4	Select unit to be displayed	auto , μS/cm, mS/cm, S/cm, μS/m, mS/m, S/m, kΩ·cm, MΩ·cm, kΩ·m		When “auto” is selected, the maximum resolution possible is automatically selected. A4 not active if A1 = conc.
A5	Enter cell constant for connected sensor	cond: 1.000 cm ⁻¹ ind: 1.98 cm ⁻¹ MΩm: 0.01 cm ⁻¹ 0.0025 to 99.99 cm ⁻¹		For the exact value of the cell constant, refer to the quality certificate.
A6	Enter cable resistance	0 Ω 0 to 99.99 Ω		Only with conductive sensors. Multiply the standardized line resistance by the actual cable length. CYK71: 0.165 Ω/m
A7	Enter measured value damping	1 1 to 60		Measured value damping causes averaging over the specified number of individual measured values. It is used, for example, to stabilize the display with applications that fluctuate a great deal. There is no damping if “1” is entered.

6.4.2 Setup 2 (Temperature)

The temperature coefficient α specifies the change in conductivity per degree of temperature change:

$$\kappa(T) = \kappa(T_0) \cdot (1 + \alpha \cdot (T - T_0))$$

with

$\kappa(T)$ = conductivity at process temperature T

$\kappa(T_0)$ = conductivity at reference temperature T_0

The temperature coefficient depends on the chemical composition of the medium and the temperature itself.

In order to compensate for this dependence, four different compensation types can be selected in the transmitter:

- Linear temperature compensation
- NaCl compensation
- Ultrapure water compensation NaCl (neutral compensation)
- Ultrapure water compensation HCl (acid compensation)
- Temperature compensation with table

Linear temperature compensation

The change between two temperature points is considered to be constant, i.e. $\alpha = \text{const}$. The α value can be edited for the linear compensation type. You can edit the reference temperature in field B7, the factory setting is 25 °C (77 °F).

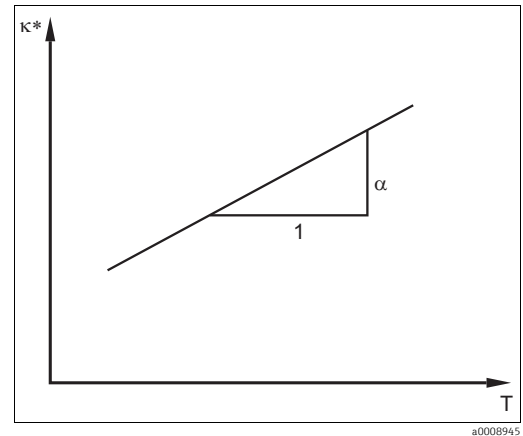

Fig. 22: Linear temperature compensation

* uncompensated conductivity

NaCl compensation

The NaCl compensation (according to IEC 60746) is based on a fixed nonlinear curve that defines the relationship between the temperature coefficient and the temperature. This curve is used for lower concentrations of up to approx. 5 % NaCl.

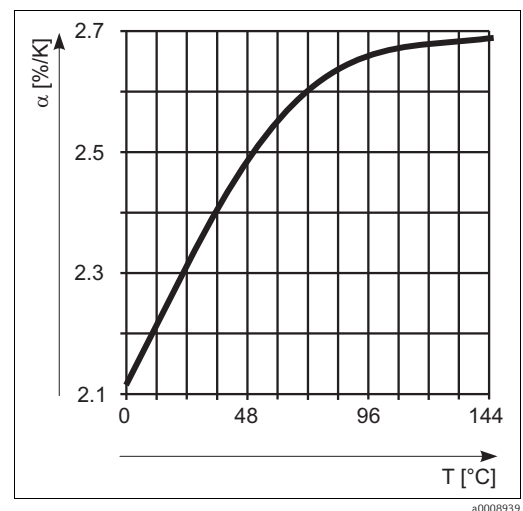

Fig. 23: NaCl compensation

Ultrapure water compensation (for conductive sensors)

For pure and ultrapure water, algorithms are saved in the transmitter that account for the self-dissociation of ultra pure water and its strong temperature dependency. They are used for conductivities of approx. 100 $\mu\text{S}/\text{cm}$.

Two compensation types are available:

- NaCl ultrapure water compensation: It is optimized for pH neutral impurities.
- HCl ultrapure water compensation: It is optimized for measurement of the so-called acid conductivity after a cation exchanger. It is also suitable for ammonia (NH_3) and caustic soda (NaOH).

i The ultrapure water compensations always refer to a reference temperature of 25 °C (77 °F).

The lowest indicated conductivity is the theoretical limit value of ultrapure water at 25 °C (77 °F), i.e. 0.055 $\mu\text{S}/\text{cm}$.

Temperature compensation with table

In case of transmitter with Plus package you can enter a table with temperature coefficients α in relation to temperature. When using the alpha table function for temperature compensation, the following conductivity data of the process medium to be measured is required:

Value pairs of temperature T and conductivity κ with:

- $\kappa(T_0)$ for the reference temperature T_0
- $\kappa(T)$ for temperatures which occur in the process

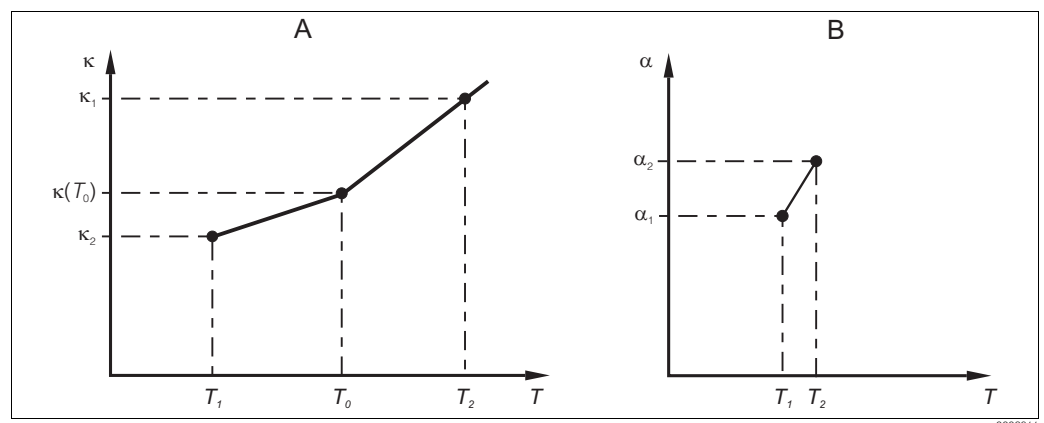

Fig. 24: Determination of temperature coefficient



A Required data
B Calculated α values

Use the following formula to calculate the α values for the temperatures occurring in your process:

$$\alpha = \frac{100\% \cdot \kappa(T) - \kappa(T_0)}{\kappa(T_0)} \cdot \frac{T - T_0}{T - T_0}; T \neq T_0$$

Enter the α - T value pairs calculated with this formula in the fields T4 and T5 of the function group "ALPHA TABLE".

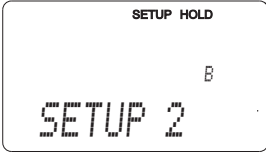
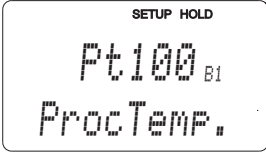
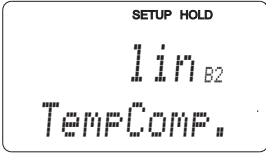
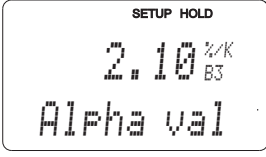
In the SETUP 2 function group, you can change the settings for temperature measurement. Basic version does not include functions in *italic*.

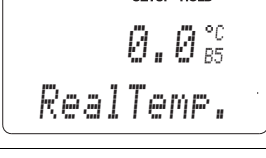
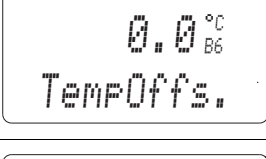
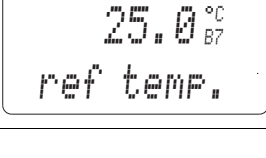
Coding	Field	Selection or range (factory settings bold)	Display	Info
B	Function group SETUP 2			Settings for temperature measurement.
B1	Select temperature sensor	Pt100 Pt1k = Pt 1000 NTC30 fixed		If set to "fixed": Manual temperature compensation (MTC), no temperature measurement if fixed temperature value is specified in B4. No temperature output if "fixed"!
B2	Select temperature compensation type	none lin = linear NaCl = common salt (IEC 60746) Pure = ultrapure water NaCl PureH = ultrapure water HCl Tab = table		This option is not displayed for concentration measurement. "Pure" and "PureH" are only available for conductive devices.
B3	Enter temperature coefficient α	2.10 %/K 0.00 to 20.00 %/K		Only if B2 = lin. With other settings in B2, field B3 has no influence.
B4	Enter process temperature	25 °C -35.0 to 250.0 °C		Only if B1 = fixed. This value can only be specified in °C.
B5	Display temperature and calibrate temperature sensor	Display and entry of real temperature -35.0 to 250.0 °C		This entry is used to calibrate the temperature sensor to an external measurement. Effects B6. Omitted if B1 = fixed.
B6	Enter temperature difference (offset)	Curent offset -5.0 to 5.0 °C		The offset is the difference between the entered actual value and the measured temperature. Omitted if B1 = fixed.
B7	Enter reference temperature	25 °C -5.0 to 100 °C		

6.4.3 Current input

To use the "Current input" function group, you need a relay board with current input which is not part of the basic version. With this function group you can monitor process parameters and use these for feedforward control. For this purpose, you must connect the current output of an external measured variable (e.g. flowmeter) to the 4 to 20 mA input of the transmitter. The following assignment applies:

Flow in main stream	Current signal in mA	Current input signal in %
Flowmeter start of measuring range	4	0
Flowmeter end of measuring range	20	100

Monitoring of flow in main stream

This arrangement is particularly practical if the sample flow through a flow assembly in an open outlet is completely independent of the flow in the main stream.

This permits signalling of an alarm condition in the main stream (flow too low or has completely stopped) and triggers dosing switch-off even if the medium flow is retained due to the method of installation.

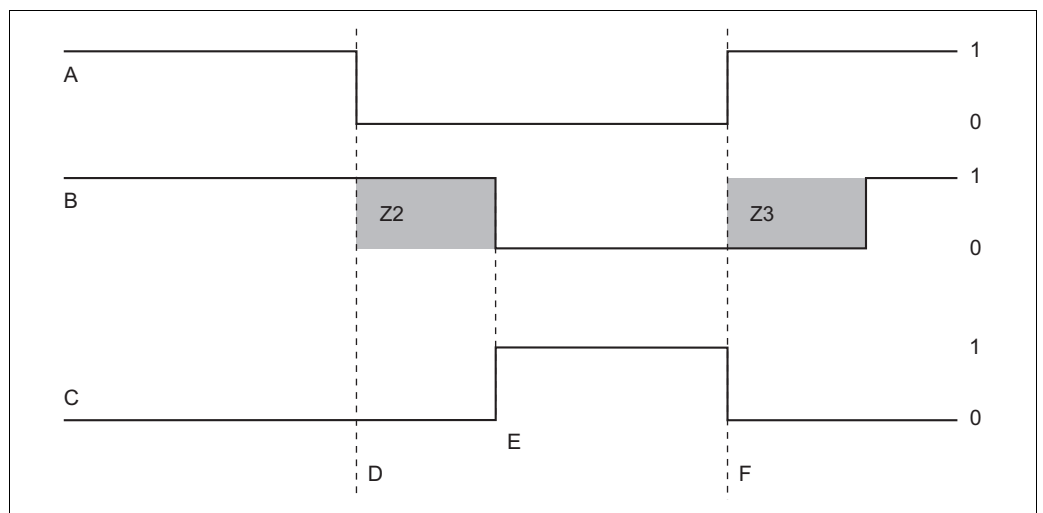

Fig. 25: Alarm signalling and dosing switch-off by the main stream

- A Flow in main stream
- B Relay contacts of PID controller
- C Alarm relay
- D Flow below switch-off limit Z4 or flow failure
- E Flow alarm
- F Flow restoration
- Z2 Delay for controller switch-off, see field Z2
- Z3 Delay for controller switch-on, see field Z3
- 0 Off
- 1 On

Feedforward control to PID controller

For control systems with very short reaction times, you can optimize the control.

Additionally you measure the flow rate of the medium. This flow rate value (0/4 to 20 mA) you apply as feedforward control to the PID controller.

Feedforward control is a multiplying function as illustrated in the figure below (example with factory setting):

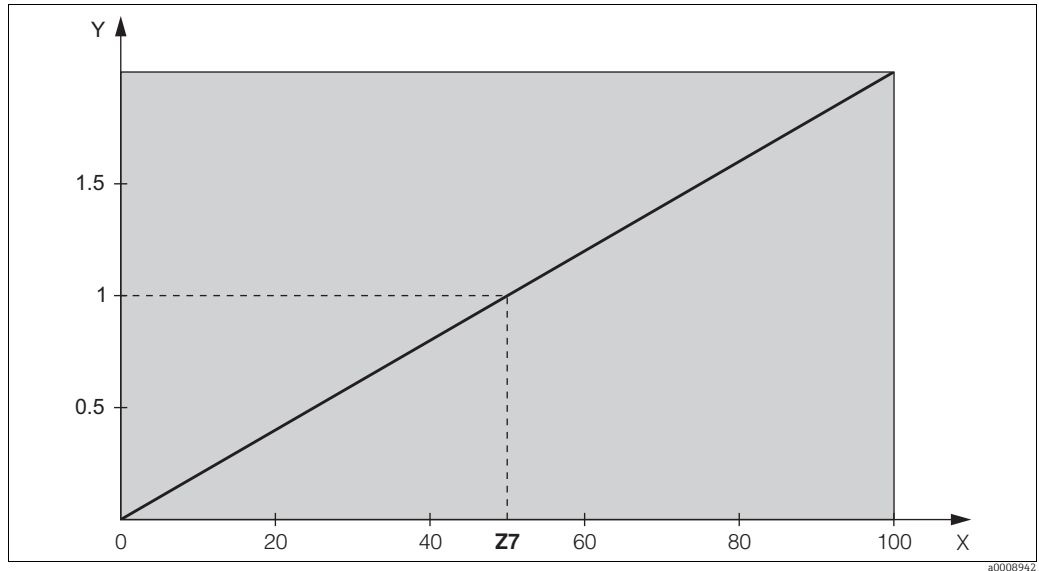

Fig. 26: Multiplying feedforward control

Y Gain K_{ff}
X Current input signal [%]
Z7 Input value, when gain $K_{ff} = 1$

The basic version does not include functions in *italic*.

Coding	Field	Setting range (Factory settings, bold)	Display	Info
Z	CURRENT INPUT function group			Current input settings.
Z1	Select flow monitoring of main stream (with controller switch-off)	Off On		Flow monitoring may only be switched on if the flowmeter is connected in the main stream. If Z1 = off, fields Z2 to Z5 are not available.
Z2	Enter the delay for controller switch-off through current input	0 s 0 to 2000 s		Brief flow shortfalls can be suppressed by a delay and do not result in controller switch-off.
Z3	Enter the delay for controller switch-on through current input	0 s 0 to 2000 s		In the case of a controller, a delay until a representative measured value is received is useful if the flow fails for an extended period.
Z4	Enter the switch-off limit value for the current input	50% 0 to 100%		0 to 100% corresponds to 4 to 20 mA at the current input. Observe measured value assignment to the current output of the flowmeter.
Z5	Enter the switch-off direction for the current input	Low High		The controller is switched off if the value entered in Z4 is undershot or overshoot.
Z6	Select feedforward control to PID controller	Off <i>Lin = linear</i> <i>Basic</i>		If Z6 = off, the field Z7 is not available. Z6 = basic: disturbance variable only affects the basic load (alternatively dosing in proportion to quantity can be used if usual PID controlling is not possible, due to a defective sensor, for example).
Z7	Enter value for feedforward control at which gain = 1 applies	50% 0 to 100%		When the value is set, the controller actuating variable is the same size when feedforward control is switched on as when feedforward control is switched off.

6.4.4 Current outputs

Use the "Current output" function group to configure the individual outputs. You can enter either a linear characteristic (O3 (1)) or a user-defined current output characteristic in conjunction with the Plus Package (O3 (3)). Exception: if you have chosen a "continuous controller" for current output 2, you cannot enter a user-defined current output characteristic for this current output.

In addition, you can also simulate a current output value (O3 (2)) to check the current outputs.

If a second current output is present, you can output the controller actuating variable in accordance with field R237 / O2 via the current output.

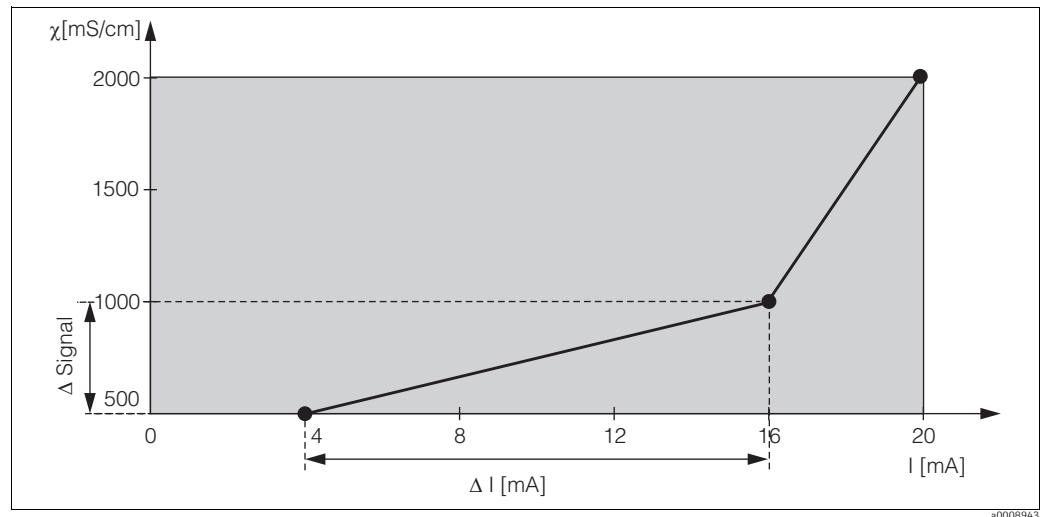



Fig. 27: User-defined current output characteristic (example)

The current output characteristic must be strictly monotonously increasing or strictly monotonously decreasing.

The distance per mA between two table value pairs must be greater than:

- Conductivity: 0.5 % of measuring range per mA
- Temperature: 0.25 °C per mA

The values for the sample characteristic (→  27) are entered in the following table. The distance per mA can be calculated from $\Delta \text{ signal} / \Delta \text{ mA}$.

Value pair	Current output 1			Current output 2		
	[mS/cm] [%] [°C]	Current [mA]	Distance per mA	[mS/cm] [%] [°C]	Current [mA]	Distance per mA
1	500	4				
2	1000	16	41.66			
3	2000	20	250			

First enter the desired current output configuration into the following blank table with a pencil. Calculate the resulting signal distance per mA to observe the necessary minimum slope. Then enter the values in the device.

Value pair	Current output 1			Current output 2		
	[mS/cm] [%] [°C]	Current [mA]	Distance per mA	[mS/cm] [%] [°C]	Current [mA]	Distance per mA
1						
2						
3						
4						
5						
6						
7						
8						
9						



Basic version does not include functions in *italic*.

Coding	Field	Setting range (Factory settings, bold)	Display	Info
0	CURRENT OUTPUT function group			Configuration of the current output (does not apply for PROFIBUS).
01	Select current output	Out1 <i>Out 2</i>		A characteristic can be selected for every output.
02	Select measured variable for 2nd current output	°C <i>mS/cm, MΩ, % Contr</i>		R237/R 266 = curr (current output 2) can only be selected if O2 = Contr is selected (relay board required).
03 (1)	Enter or output linear characteristic	Lin = linear (1) <i>Sim = simulation (2) Tab = table (3)</i>		The characteristic can have a positive or negative slope for the measured value output. In the case of actuating variable output (O2 = Contr), an increasing current corresponds to an increasing actuating variable.
0311	Select current range	4 to 20 mA <i>0 to 20 mA</i>		
0312	0/4 mA value: Enter corresponding measured value	cond/ind: 0.00 μS/cm MOhm: 0.00 kΩ·cm Conc: 0.00 % Temp: 0.00 °C		Here you can enter the measured value at which the min. current value (0/4 mA) is applied at the transmitter output. (Spreading: see Technical data.)
0313	20 mA value: Enter corresponding measured value	cond/ind: 2000 mS/cm MOhm: 500 kΩ·cm Conc: 99.99 % Temp: 150 °C		Here you can enter the measured value at which the max. current value (20 mA) is applied at the transmitter output. (Spreading: see Technical data.)
03 (2)	Simulate current output	Lin = linear (1) Sim = simulation (2) <i>Tab = table (3)</i>		Simulation is not ended until (1) or (3) is selected. For further characteristics, see O3 (1), O3(3).
0321	Enter simulation value	Current value 0.00 to 22.00 mA		Entering a current value results in this value being directly output at the current output.

Coding	Field	Setting range (Factory settings, bold)	Display	Info
O3 (3)	Enter current output table (only for Plus Package)	Lin = linear (1) Sim = simulation (2) Tab = table (3)		Values can also be added or altered at a later stage. The values entered are automatically sorted by increasing current value. For further characteristics, see O3 (1), O3 (2).
O331	Select table options	Read Edit		
O332	Enter number of table value pairs	1 1 to 10		Enter the number of pairs from the x and y value (measured value and current value) here.
O333	Select table value pair	1 1 to No. elem. Assign		The function chain O333 to O335 will run through as many times as correspond to the value in O332. "Assign" appears as the last step. After confirmation the system jumps to O336.
O334	Enter x value	cond/ind: 0.00 μS/cm MOhm: 0.00 kΩ.cm Conc: 0.00 % Temp: 0.00 $^{\circ}$C		x value = measured value specified by user.
O335	Enter y value	4.00 mA 0.00 to 20.00 mA		y value = current value belonging to O334 specified by user. Return to O333 until all values are entered.
O336	Message as to whether table status is OK	yes no		Back to O3. If status = no, correct table (all settings made up until now are retained) or back to measuring mode (table is deleted).

6.4.5 Alarm

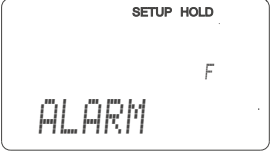
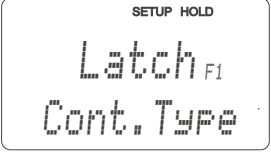
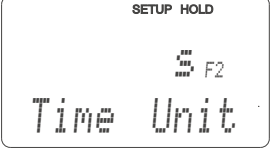
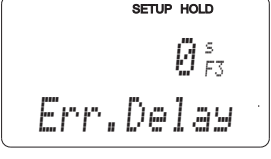
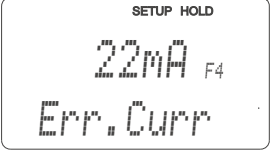
In the ALARM function group, you can define various alarms and configure output contacts. Each individual error can be defined to be effective or not (at the contact or as an error current).

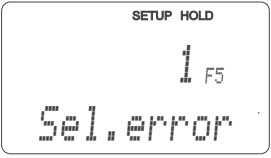
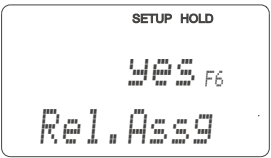
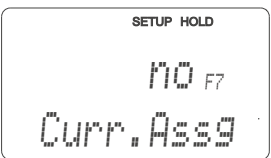
Coding	Field	Setting range (Factory settings, bold)	Display	Info
F	ALARM function group		 The display shows "SETUP HOLD" at the top, "F" in the middle, and "ALARM" at the bottom.	Alarm function settings.
F1	Select contact type	Latch = latching contact Momen = momentary contact	 The display shows "SETUP HOLD" at the top, "Latch F1" in the middle, and "Cont.Type" at the bottom.	The contact type selected only applies to the alarm contact.
F2	Select time unit	s min	 The display shows "SETUP HOLD" at the top, "s F2" in the middle, and "Time Unit" at the bottom.	
F3	Enter alarm delay	0 s (min) 0 to 2000 s (min)	 The display shows "SETUP HOLD" at the top, "0 s F3" in the middle, and "Err.Delay" at the bottom.	Depending on the option selected in F2, the alarm delay is entered in s or min.
F4	Select error current	22 mA 2.4 mA	 The display shows "SETUP HOLD" at the top, "22mA F4" in the middle, and "Err.Curr" at the bottom.	This selection must be made even if all error reporting is switched off in F5.  If "0-20 mA" was selected in O311, "2.4 mA" may not be used.
F5	Select error	1 1 to 255	 The display shows "SETUP HOLD" at the top, "1 F5" in the middle, and "Sel.error" at the bottom.	Here you can select all the errors which should trigger an alarm. The errors are selected via the error numbers. Please refer to the table in section 9.2 "System error messages" for the meaning of the individual error numbers. The factory settings remain in effect for all errors not edited.
F6	Set alarm contact to be effective for the selected error	yes no	 The display shows "SETUP HOLD" at the top, "yes F6" in the middle, and "Rel.Assg" at the bottom.	If "no" is selected, all the other alarm settings are deactivated (e.g. alarm delay). The settings themselves are retained. This setting only applies to the error selected in F5.
F7	Set error current to be effective for the selected error	no yes	 The display shows "SETUP HOLD" at the top, "no F7" in the middle, and "Curr.Assg" at the bottom.	The option selected in F4 is effective or ineffective in the event of an error. This setting only applies to the error selected in F5.

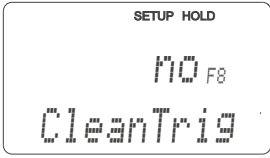
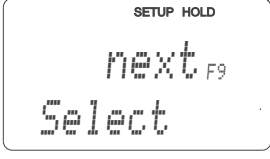
Coding		Field	Setting range (Factory settings, bold)	Display	Info
	F8	Automatic cleaning function start	no yes		This field is not available for certain errors, see "Trouble-shooting and fault elimination" section.
	F9	Select return to menu or next error	next = next error ←R		If ←R is selected, you return to F, if next is selected, you go to F5.

6.4.6 Check

The CHECK function group is only available for devices with a Plus Package. In the CHECK function group, you can select different monitoring functions for the measurement:

Polarisation detection (field P1)

Polarization effects in the interface between sensor and measuring solution limit the measuring range of conductive conductivity sensors. The transmitter has the ability to detect polarization effects using an intelligent evaluation process. Error code E071 will be generated.

Alarm threshold monitoring (fields P2 to P5)

You can use this function to monitor the measured value for permissible upper and lower limits and trigger an alarm (E154, E155).

PCS alarm (Process Check System), (fields P6 to P9)

AC (Alternating Check): The function AC (field P6) is used to check measuring signals for deviations. If the measuring signal change within an hour is smaller than 0.5% (of full scale value of the selected measuring range), an alarm (E152) is triggered. The reason for such sensor behaviour can be contamination, cable rupture or similar.

CC (Controller Check): You can monitor the controller activity with the function CC. This function is mainly used for batch processes and single-sided limit switches. A malfunction of the controller is detected and reported thanks to freely adjustable monitoring times (E156 - E157).

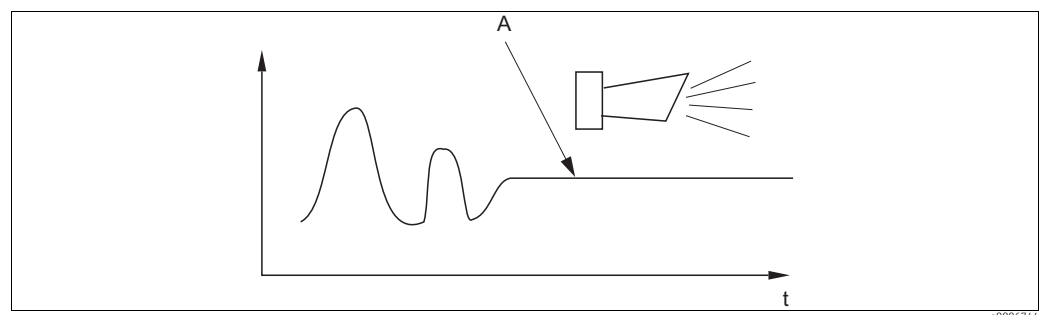

Fig. 28: PCS alarm (live check)

A Constant measuring signal = alarm triggered after PCS alarm time has elapsed

 Any PCS alarm pending is automatically deleted as soon as the sensor signal changes.

Basic version does not include functions in *italic*.

Coding	Field	Setting range (Factory settings, bold)	Display	Info
P	CHECK function group			Settings for sensor and process monitoring
P1	Switch polarization detection on or off (conductive only)	Off On		Polarization only occurs with conductive sensors. Polarization is detected, but not compensated. (error no.: E071)
P2	Set PCS Alarm (live check)	Off Low High Lo+Hi Low! High! Lo+Hi!		Alarm signalling optionally with or without simultaneous controller switch-off. XXXX = without controller switch-off XXXX! = with controller switch-off (error no.: E154, E155)
P3	Enter error delay	0 s (min) 0 to 2000 s (min)		Depending on your selection in F2, you can enter the error delay in min or s. Only after this delay does a high or low limit violation cause an alarm as per field P4/P5.
P4	Enter lower alarm threshold	0 µS/cm 0 to 9999mS/cm		
P5	Enter upper alarm threshold	9999 µS/cm 0 to 9999mS/cm		
P6	Select process monitoring (PCS alarm)	Off AC CC AC+CC AC! CC! AC+CC!		AC = sensor alternation check (E152) CC = controller check (E156, E157) Alarm signalling optionally with or without simultaneous controller switch-off. XXXX = without controller switch-off XXXX! = with controller switch-off
P7	Enter maximum permissible duration for lower CC setpoint limit violation (field P9)	60 min 0 to 2000 min		Only when P6 = CC or AC+CC
P8	Enter maximum permissible duration for upper CC setpoint limit violation (field P9)	120 min 0 to 2000 min		Only when P6 = CC or AC+CC

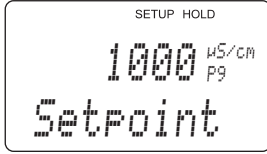
Coding		Field	Setting range (Factory settings, bold)	Display	Info
	P9	Enter CC setpoint (for P7/P8)	1000 $\mu\text{S}/\text{cm}$ 0 to 9999 mS/cm		Selected value is an absolute value. This function is mainly used for batch processes and single-sided limit switches.

6.4.7 Relay contact configuration

To use the RELAY function group you need a relay board which is not part of the basic version.

The following relay contacts can be selected and configured as desired (max. four contacts, depending on options installed):

- Limit contactor for measured conductivity value: R2 (1)
- Limit contactor for temperature: R2 (2)
- PID controller: R2 (3)
- Timer for cleaning function: R2 (4)
- Chemoclean function: R2 (5)
- USP/EP: R2 (6) and R2 (7) (for Plus Package, conductive only)

Limit contactor for measured conductivity value and temperature

The transmitter has different ways of assigning a relay contact.

Switch-on and switch-off points and pick-up and drop-out delays can be assigned to the limit contactor. In addition, you can configure an alarm threshold to output an error message and to start a cleaning function in conjunction with this.

These functions can be used both for conductivity measurement and for temperature measurement.

Please refer to Fig. 29 for a clear illustration of the relay contact states.

- When the measured values increase (maximum function), the relay contact is closed as of t_2 after the switch-on point (t_1) has been overshoot and the pick-up delay has elapsed ($t_2 - t_1$).
The alarm contact switches if the alarm threshold (t_3) is reached and the alarm delay ($t_4 - t_3$) (field F3) has also elapsed (error E067 to E070).
- When the measured values decrease, the alarm contact is reset when the alarm threshold (t_5) is undershot as is the relay contact (t_7) after the drop-out delay ($t_7 - t_6$).
- If the pick-up and drop-out delays are set to 0 s, the switch-on and switch-off points are also switch points of the contacts.

Settings can also be made for a minimum function in the same way as for a maximum function.

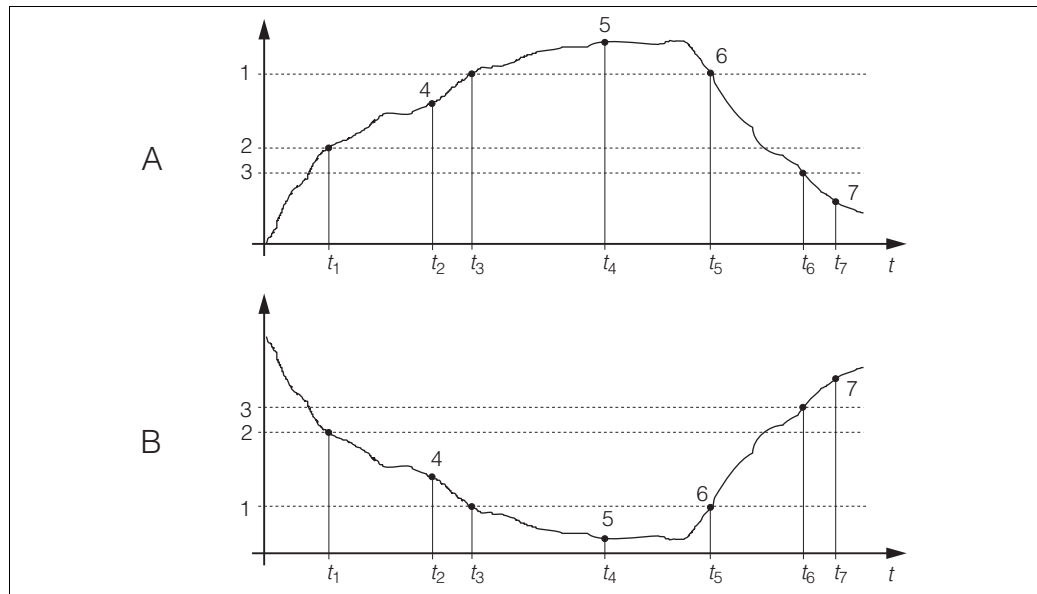

Fig. 29: Illustration of the alarm and limit value functions

A	Switch-on point > switch-off point: Max. function	1	Alarm threshold	5	Alarm ON
B	Switch-on point < switch-off point: Min. function	2	Switch-on point	6	Alarm OFF
		3	Switch-off point	7	Contact OFF
		4	Contact ON		

P(ID) controller

You can define various controller functions for the transmitter. On the basis of the PID controller, P, PI, PD and PID controllers can be implemented. For an optimum control system, use the controller that best suits your application. Depending on the option selected in the R 237/R 266 field, the actuating signal can be output via relays or via current output 2 (if available).

■ P controller

Used for simple linear control purposes with small system deviations. Where major changes are to be controlled, overshooting may occur. In addition, a lasting control deviation is to be expected.

■ PI controller

Is used for control systems where overshooting is to be avoided and no lasting control deviation should occur.

■ PD controller

Is used for processes that require quick changes and where peaks are to be corrected.

■ PID controller

Is used for processes where a P, PI or PD controller does not control sufficiently.

Configuration options of the PID controller

The following configuration options are available for a PID controller:

- Change control gain K_p (P influence)
- Set integral action time T_n (I influence)
- Set derivative action time T_v (D influence)

Basic load dosing (Basic)

The basic load dosing (field R231) is used to set a constant dosage (field R2311)

PID controlling plus basic load dosing

If you select this function (PID + Basic) in field R231 the PID controlled dosage will not be lower than the basic load value entered in field R2311.

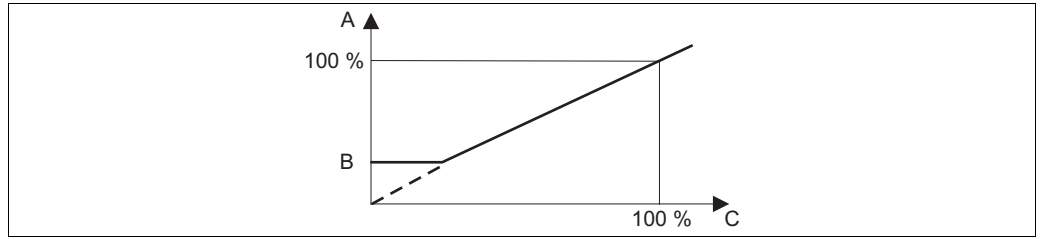

Fig. 30: Control characteristic PID controller with basic load dosing

- A PID with basic load
- B Basic load
- C PID

Commissioning

If you do not yet have any experience for setting the control parameters, set the values that yield the greatest possible stability in the control circuit. Proceed as follows to optimize the control circuit further:

- Increase the control gain K_p until the controlled variable just starts to overshoot.
- Reduce K_p slightly and then reduce the integral action time T_n so that the shortest possible correction time without overshooting is achieved.
- To reduce the response time of the controller, also set the derivative action time T_v .

Control and fine optimization of the set parameters with a recorder

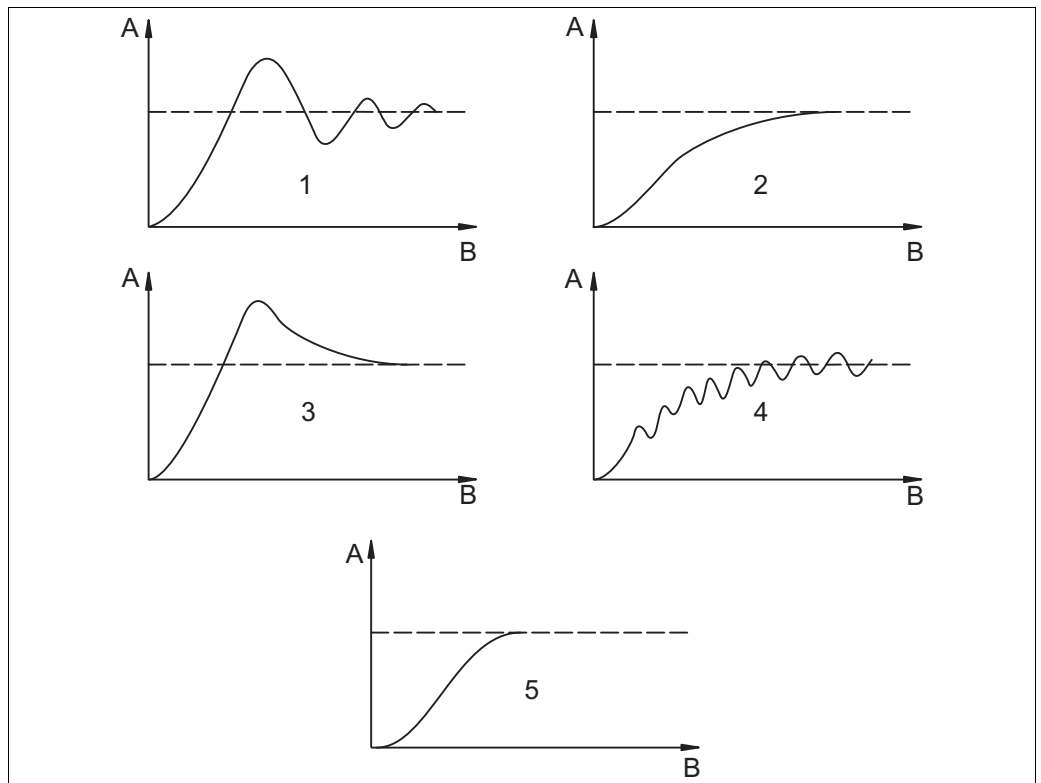

Optimization of settings T_n and K_p

- | | | | | | |
|---|--------------|---|-----------------|---|-----------------|
| A | Actual value | 1 | T_n too small | 4 | K_p too small |
| B | Time | 2 | T_n too large | 5 | Optimum setting |
| | | 3 | K_p too large | | |

Actuating signal outputs (R237 ... R2310)

Each control contact outputs a cyclical signal whose intensity corresponds to the controller's manipulated variable. A distinction is made according to the type of signal cycle:

- Pulse length modulation

The bigger the calculated manipulated variable is, the longer the contact affected remains picked up. The period T can be adjusted between 0.5 and 99 s (field R238). Outputs with pulse length modulation are used to activate solenoid valves.

- Pulse frequency modulation

The bigger the calculated manipulated variable is, the higher the switching frequency of the contact affected. The maximum switching frequency $1/T$ can be set between 60 and 180 min^{-1} . The on-time t_{ON} is constant. It depends on the set maximum frequency and is approx. 0.5 s for 60 min^{-1} and approx. 170 ms for 180 min^{-1} . Outputs with pulse frequency modulation are used to activate directly controlled solenoid dosing pumps.

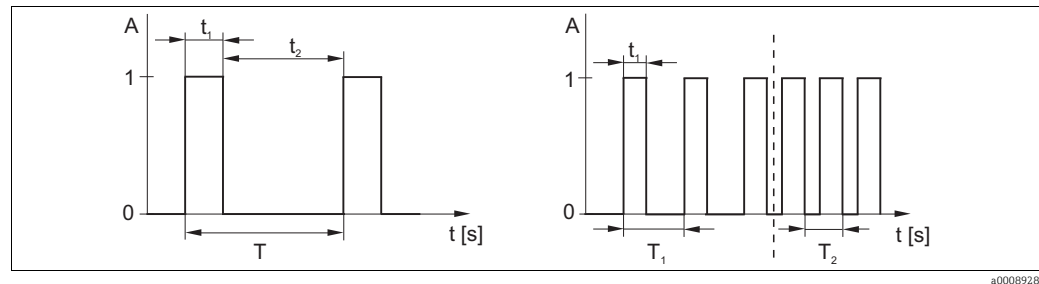

Fig. 31: Signal of a pulse-length modulated controller contact (left) and of a pulse-frequency modulated controller contact (right)
 A Contact 1 = on, 0 = off
 B Time [s] $t_1 = t_{\text{on}}$ $t_2 = t_{\text{off}}$
 T Period length
 $T_1 T_2$ Impulse period length (impulse freq. $1/T_1$ and $1/T_2$)

Constant controller

Via the current output 2, the minimum actuating variable (0 %) of the controller is output with 0/4 mA and the maximum actuating variable (100 %) of the controller is output with 20 mA.

Control characteristic for direct and inverse control action

You can choose between two control characteristics in the R236 field:

- Direct control action = maximum function
- Inverse control action = minimum function

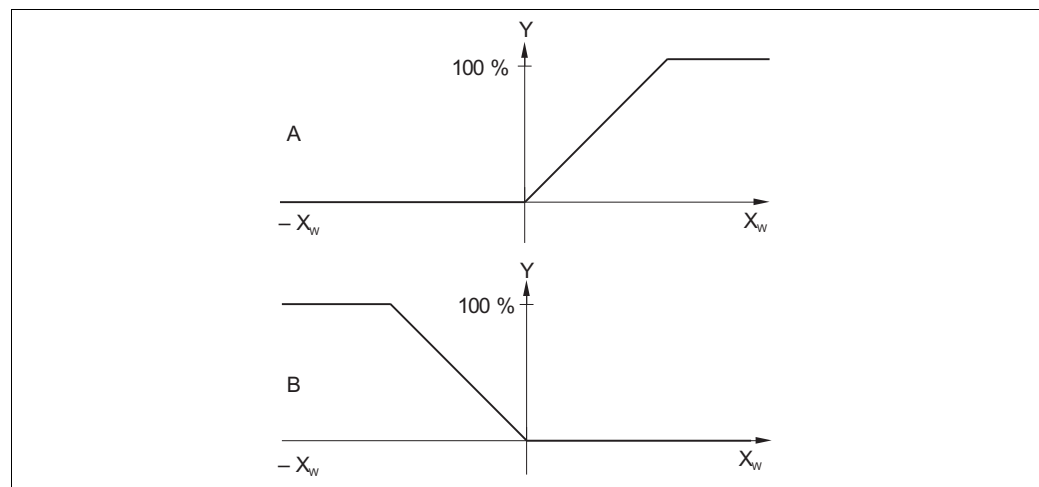

Fig. 32: Control characteristic of a proportional controller with direct and inverse control action

- A Direct = max. function
- B Inverse = min. function

Timer for cleaning function

This function includes a simple cleaning option. You can set the time interval after which cleaning should start. So you can only select a constant interval sequence. Other cleaning functions are available for selection in conjunction with the Chemoclean function (version with four contacts, see "Chemoclean function" section).

i Timer and Chemoclean do not work independently of one another. While one of the two functions is active, the other cannot be started.

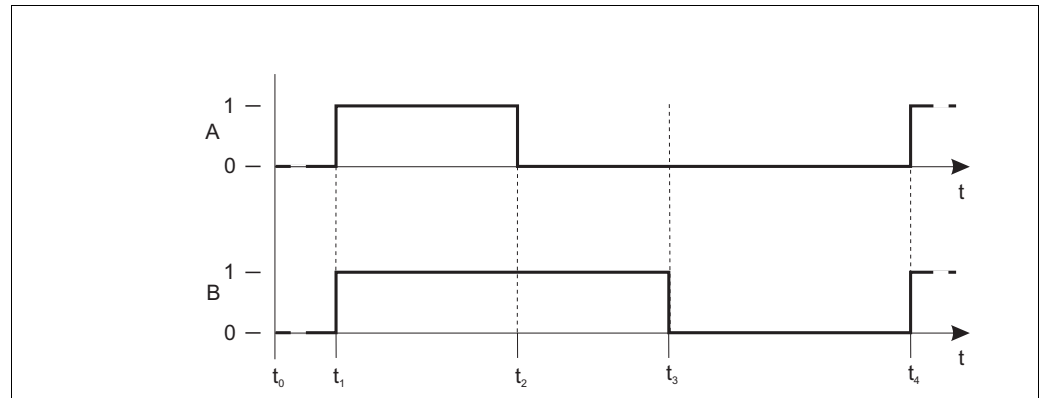

Fig. 33: Correlation of cleaning time, pause time and hold dwell period

A Wiper and/or spray cleaning system

B Hold function

0 Inactive

1 Active

t_0 Normal mode

t_1 Cleaning start

t_2-t_1 Cleaning time

t_3-t_2 Clean hold dwell period (0 to 999 s)

t_4-t_3 Pause time between two cleaning intervals
(1 to 7200 min)

Chemoclean function

Just like the timer function, Chemoclean can also be used to start a cleaning cycle. However, Chemoclean also gives you the added option of defining different cleaning and rinsing intervals.

As a result, it is possible to clean irregularly with different repeat cycles and to separately set the cleaning times with post rinse times.

Pay attention to the following:

- To use the Chemoclean function the transmitter has to be equipped with a designated relay board (see product structure or chapter "accessories").
- Timer and Chemoclean do not work independently of one another. While one of the two functions is active, the other cannot be started.
- For the Chemoclean function, the relays 3 (water) and 4 (cleaner) are used.
- If cleaning is prematurely aborted, a post rinse time always follows.
- If the setting is "Economy", cleaning only takes place with water.

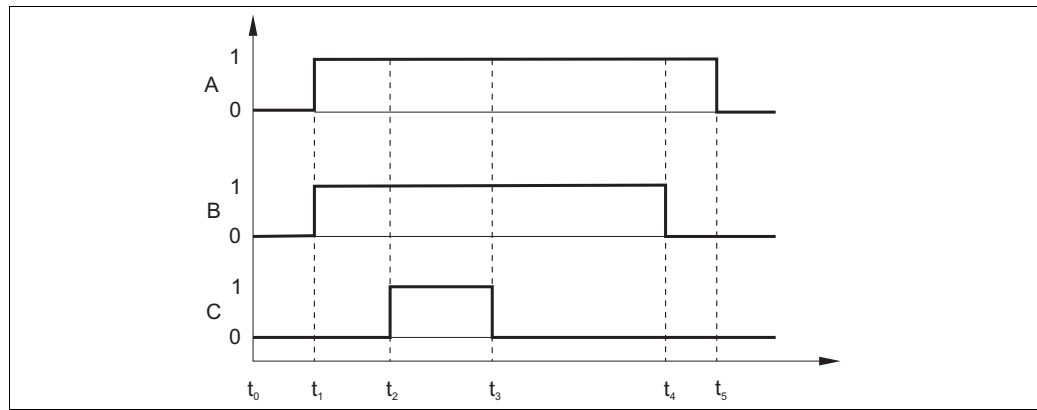

Fig. 34: Sequence of a cleaning cycle

A Hold
 B Water
 C Cleaner
 0 Contact on
 1 Contact off

t_0 Normal mode
 t_1 Cleaning start
 $t_2 - t_1$ Pre-rinse time
 $t_3 - t_2$ Cleaning time
 $t_4 - t_3$ Post rinse time
 $t_5 - t_4$ Hold dwell period

Limit values for pharmaceutical water according to United States Pharmacopeia (USP) and European Pharmacopoeia (EP) (conductive only)

The transmitter (conductive sensors only) can monitor "Water for Injection" (WFI), "Highly Purified Water" (HPW) and "Purified Water" (PW) according to the standard United States Pharmacopeia (USP) part 645 and European Pharmacopoeia (EP).

USP function: For "Water for Injection" (WFI) according to the standard of USP and EP and for "Highly Purified Water" (HPW) according to the standard of EP the transmitter uses the temperature depending limit values of the following table:

Temperature [°C/°F]	Conductivity [$\mu\text{S}/\text{cm}$]	Temperature [°C/°F]	Conductivity [$\mu\text{S}/\text{cm}$]
0/32	0.6	55/131	2.1
5/41	0.8	60/140	2.2
10/50	0.9	65/149	2.4
15/59	1.0	70/158	2.5
20/68	1.1	75/167	2.7
25/77	1.3	80/176	2.7
30/86	1.4	85/185	2.7
35/95	1.5	90/194	2.7
40/104	1.7	95/203	2.9
45/113	1.8	100/212	3.1
50/122	1.9		

The measurement is performed as follows:

- The transmitter determines the uncompensated conductivity and the water temperature.
- The transmitter rounds off the temperature to the next smaller 5 °C step and compares the actual measured conductivity with the value of the table.
- If the measured value exceeds the table value an alarm (E151) will be triggered.

EP-PW function: For "Purified Water" (PW) according to the standard of EP the transmitter uses the temperature depending limit values of the following table:

Temperature [°C/°F]	Conductivity [$\mu\text{S}/\text{cm}$]	Temperature [°C/°F]	Conductivity [$\mu\text{S}/\text{cm}$]
0/32	2.4	60/140	8.1
10/50	3.6	70/158	9.1
20/68	4.3	75/167	9.7
25/77	5.1	80/176	9.7
30/86	5.4	90/194	9.7
40/104	6.5	100/212	10.2
50/122	7.1		

The measurement is performed as follows:

- The transmitter determines the uncompensated conductivity and the water temperature .
- The transmitter determines the conductivity limit value by interpolation of two table values.
- If the measured value exceeds the table value an alarm (E151) will be triggered.



Prealarm: Also available is a pre-alarm with a user defined switch-on point (e.g. 80 % of the USP/EP value). This gives the user a signal for the in-time regeneration of the system. Enter the value in field R262 or R272.

Pay attention to the following:

- To use the USP and EP functions the transmitter has to be equipped with a relay board and the Plus Package.
- For alarm output, activate the fault-signalling contact or the error current in field F5 - F7 (error code E151 and E153).
- The switch-off point of the pre-alarm is 1 % below of the switch-on point (R262 / R272), related to the main limit value.
- The transmitter uses uncompensated values for the USP and EP functions even in case temperature compensated values are displayed.
- At temperatures above 100 °C (212 °F) the transmitter uses the limit value of 100 °C (212 °F).

Basic version does not include functions in *italic*.

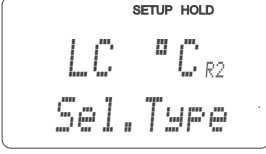
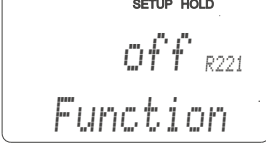
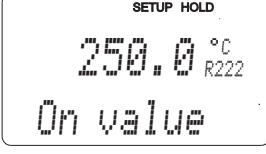
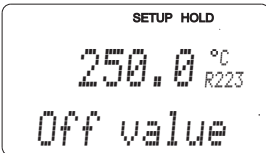
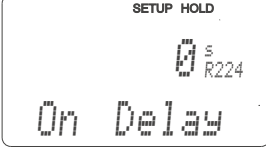
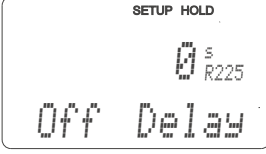
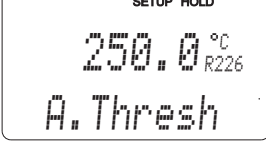
Coding	Field	Setting range (Factory settings, bold)	Display	Info
R	RELAY function group			Relay contact settings.
R1	Select contact to be configured	Rel1 <i>Rel2</i> <i>Rel3</i> <i>Rel4</i>		Rel3 (water) and Rel4 (cleaner) are only available with the relevant version of the transmitter. If Chemoclean is used as the cleaning method, Rel4 is not available.
R2 (1)	Configuration limit contactor for conductivity, resistivity or concentration measurement	LC PV = limit contactor cond (1) LC °C = limit contactor T (2) PID controller (3) Timer (4) <i>Clean = Chemoclean (5)</i> <i>USP (6)</i> <i>EP PW (7)</i>		PV = process value If Rel4 is selected in the R1 field, Clean = Chemoclean cannot be selected. By confirming with ENTER, another relay function already switched on is switched off and its settings are reset to the factory settings.
R211	Switch function of R2 (1) off or on	Off On		All the settings are retained.
R212	Enter the switch-on point of the contact	cond/ind: 9999 mS/cm MOhm: 200 MΩ·cm conc: 9999 %		Never set the switch-on point and the switch-off point to the same value! (Only the operating mode selected in A1 is displayed.)
R213	Enter the switch-off point of the contact	cond/ind: 9999 mS/cm MOhm: 200 MΩ·cm conc: 9999 %		Entering a switch-off point selects either a Max contact (switch-off point < switch-on point) or a Min contact (switch-off point > switch-on point), thereby implementing a hysteresis that is constantly required (see "Illustration of the alarm and limit functions" figure).
R214	Enter pick-up delay	0 s 0 to 2000 s		
R215	Enter drop-out delay	0 s 0 to 2000 s		
R216	Enter alarm threshold	cond/ind: 9999 mS/cm MOhm: 200 MΩ·cm conc: 9999 %		If the alarm threshold is undershot/overshot, this triggers an alarm with the error message (E067 to E070) and error current at the transmitter (note alarm delay in field F3). If defined as a Min contact, the alarm threshold must be < switch-off point.

Coding		Field	Setting range (Factory settings, bold)	Display	Info
	R217	Display status for limit contactor	MAX MIN		Display only.
	R2 (2)	Configure limit contactor for temperature measurement	LC PV = limit contactor cond (1) LC °C = limit contactor T (2) PID controller (3) Timer (4) <i>Clean = Chemoclean (5)</i> <i>USP (6)</i> <i>EP PW (7)</i>		By confirming with ENTER, another relay function already switched on is switched off and its settings are reset to the factory settings.
	R221	Switch function of R2 (2) off or on	Off On		
	R222	Enter switch-on temperature	250.0 C -35.0 to 250.0 C		Never set the switch-on point and the switch-off point to the same value!
	R223	Enter switch-off temperature	250.0 C -35.0 to 250.0 C		Entering a switch-off point selects either a Max contact (switch-off point < switch-on point) or a Min contact (switch-off point > switch-on point), thereby implementing a hysteresis that is constantly required (see "Illustration of the alarm and limit functions" figure).
	R224	Enter pick-up delay	0 s 0 to 2000 s		
	R225	Enter drop-out delay	0 s 0 to 2000 s		
	R226	Enter alarm threshold (as absolute value)	250.0 C -35.0 to 250.0 C		If the alarm threshold is undershot/overshot, this triggers an alarm with the error message (E067 to E070) and error current at the transmitter (note alarm delay in field F3). If defined as a Min contact, the alarm threshold must be < switch-off point.
	R227	Display status for limit contactor	MAX MIN		Display only.

Coding	Field	Setting range (Factory settings, bold)	Display	Info
R2 (3)	Configure P(ID) controller	LC PV = limit contactor cond (1) LC °C = limit contactor T (2) PID controller (3) Timer (4) <i>Clean = Chemoclean (5)</i> <i>USP (6)</i> <i>EP PW (7)</i>	<p>SETUP HOLD PID R2 Sel.Type</p>	By confirming with ENTER, another relay function already switched on is switched off and its settings are reset to the factory settings.
R231	Switch function of R2 (3) off or on	Off On Basic PID+B	<p>SETUP HOLD off R231 Function</p>	On = PID controller Basic = basic load dosing PID+B = PID controller + basic load dosing
R232	Enter set point	cond/ind: 0.00 mS/cm MOhm: 0.00 kΩ·cm conc: 0.00 %	<p>SETUP HOLD 0.00 μS/cm R232 Setpoint</p>	The set point is the value to be maintained by the control system. Using this control process, this value is restored upwards or downwards when a deviation occurs.
R233	Enter control gain K_p	1.00 0.01 to 20.00	<p>SETUP HOLD 1.00 R233 Kp</p>	See "P(ID) controller" section.
R234	Enter integral action time T_n (0.0 = no I-component)	0.0 min 0.0 to 999.9 min	<p>SETUP HOLD 0.0 min R234 Time Tn</p>	See "P(ID) controller" section. With every Hold, the I-component is set to zero. Although Hold can be deactivated in field S2, this does not apply for Chemoclean and timer!
R235	Enter derivative action time T_v (0.0 = no D-component)	0.0 min 0.0 to 999.9 min	<p>SETUP HOLD 0.0 min R235 Time Tv</p>	See "P(ID) controller" section.
R236	Select controller characteristic	dir = direct inv = inverse	<p>SETUP HOLD dir R236 Direction</p>	The setting is required depending on the control deviation (upward or downward deviation, see "P(ID) controller" section).
R237	Select pulse length or pulse frequency	len = pulse length freq = pulse frequency <i>curr = current output 2</i>	<p>SETUP HOLD len R237 Oper.Mode</p>	Pulse length e.g. for solenoid valve, pulse frequency e.g. for solenoid dosing pump, see "Actuating signal outputs" section. Curr = current output 2 can only be selected if O2 = Contr.
R238	Enter pulse interval	10.0 s 0.5 to 999.9 s	<p>SETUP HOLD 10.0 s R238 PulsePer.</p>	This field only appears if pulse length is selected in R237. If pulse frequency is selected, R238 is skipped and entries continue with R239.

Coding		Field	Setting range (Factory settings, bold)	Display	Info
	R239	Enter maximum pulse frequency of the adjuster	120 min⁻¹ 60 to 180 min ⁻¹		This field only appears if pulse frequency is selected in R237. If pulse length is selected, R239 is skipped and entries continue with R2310.
	R2310	Enter minimum switch-on time t _{ON}	0.3 s 0.1 to 5.0 s		This field only appears if pulse length is selected in R237.
	R2311	Enter basic load	0 % 0 to 40 %		When you select the basic load, you enter the desired dosing quantity. 100% basic load would correspond to: – Constantly on for R237 = len – Fmax at R237 = freq (field R239) – 20 mA at R237 = curr
R2 (4)		Configure cleaning function (timer)	LC PV = limit contactor cond (1) LC °C = limit contactor T (2) PID controller (3) Timer (4) Clean = Chemoclean (5) USP (6) EP PW (7)		Cleaning only takes place with one cleaning agent (usually water); see Fig. 41). By confirming with ENTER, another relay function already switched on is switched off and its settings are reset to the factory settings.
	R241	Switch function of R2 (4) off or on	Off On		
	R242	Enter rinsing/cleaning time	30 s 0 to 999 s		Settings for Hold and relay are active for this time.
	R243	Enter pause time	360 min 1 to 7200 min		The pause time is the time between two cleaning cycles (see "Timer for cleaning function" section).
	R244	Enter minimum pause time	120 min 1 to R243 min		The minimum pause time prevents constant cleaning if a cleaning trigger is present.
R2 (5)		Configure cleaning with Chemoclean (for version with four contacts, Chemoclean option and contacts 3 and 4 assigned)	LC PV = limit contactor cond (1) LC °C = limit contactor T (2) PID controller (3) Timer (4) Clean = Chemoclean (5) USP (6) EP PW (7)		See "Chemoclean function" section. By confirming with ENTER, another relay function already switched on is switched off and its settings are reset to the factory settings.

Coding	Field	Setting range (Factory settings, bold)	Display	Info
R251	Switch function of R2 (5) off or on	Off On		
R252	Select type of start pulse	Int = internal (time-controlled) Ext = external (digital input 2) I+ext = internal + external I+stp = internal, suppressed by external		The cycle for the "int" function is started by the end of the pause time (R257). No real time clock is available. External suppression is required for irregular time intervals (e.g. weekends).
R253	Enter pre-rinse time	20 s 0 to 999 s		Rinsing with water takes place.
R254	Enter cleaning time	10 s 0 to 999 s		Cleaning with cleaning agent and water takes place.
R255	Enter post rinse time	20 s 0 to 999 s		Rinsing with water takes place.
R256	Enter number of repeat cycles	0 0 to 5		R253 to R255 is repeated.
R257	Enter pause time	360 min 1 to 7200 min		The pause time is the time between two cleaning cycles (see "Timer function" section).
R258	Enter minimum pause time	120 min 1 to R257 min		The minimum pause time prevents constant cleaning if an external cleaning start is present.
R259	Enter number of cleaning cycles without cleaning agent (economy function)	0 0 to 9		After cleaning with cleaner, up to 9 cleaning sessions can be carried out with water only until the next cleaning session with cleaner takes place.

Coding	Field	Setting range (Factory settings, bold)	Display	Info
R2 (6)	Configure USP contact	LC PV = limit contactor cond (1) LC °C = limit contactor T (2) PID controller (3) Timer (4) Clean = Chemoclean (5) USP (6) EP PW (7)		The USP contact can be configured as a pre-alarm, i.e., it issues an alarm before the limit is reached. When an alarm is output, the error no. E151 is displayed. By confirming with ENTER, another relay function already switched on is switched off and its settings are reset to the factory settings. WFI acc. to USP and EP; HPW acc. to EP
R261	Switch function of R2 (6) off or on	Off On		
R262	Pre-alarm threshold: Enter switch-on point	80 % 0.0 to 100.0 %		The pre-alarm effects a contact query. Should the alarm value be reached (100 %) the alarm relay also responds. Example: At 15 °C and 1.0 µS/cm with the setting 80.0 % an USP-pre-alarm is also triggered at 0.8 µS/cm.
R264	Pre-alarm threshold: Enter pick-up delay	0 s 0 to 2000 s		
R265	Pre-alarm threshold: Enter drop-out delay	0 s 0 to 2000 s		
R2 (7)	Configure EP PW contact	LC PV = limit contactor cond (1) LC °C = limit contactor T (2) PID controller (3) Timer (4) Clean = Chemoclean (5) USP (6) EP PW (7)		The EP PWcontact can be configured as a pre-alarm, i.e., it issues an alarm before the limit is reached. When an alarm is output, the error no. E151 is displayed. By confirming with ENTER, another relay function already switched on is switched off and its settings are reset to the factory settings. PW acc. to EP
R271	Switch function of R2 (7) off or on	Off On		
R272	Pre-alarm threshold: Enter switch-on point	80 % 0.0 to 100.0 %		The pre-alarm effects a contact query. Should the alarm value be reached (100 %) the alarm relay also responds. Example: At 15 °C and 1.0 µS/cm with the setting 80.0 % an EP PW-pre-alarm is also triggered at 0.8 µS/cm.
R274	Pre-alarm threshold: Enter pick-up delay	0 s 0 to 2000 s		

Coding		Field	Setting range (Factory settings, bold)	Display	Info
	R275	Pre-alarm threshold: Enter drop-out delay	0 s 0 to 2000 s		

6.4.8 Temperature compensation with table

You need the Plus Package to use the function group "ALPHA TABLE". This function group is used to perform a temperature compensation with table (field B2).

Enter the α -T value pairs in the fields T4 and T5.

Basic version does not include functions in *italic*.

Coding		Field	Selection or range (factory settings bold)	Display	Info
T		Function group ALPHA TABLE			Settings for temperature compensation.
	T1	Select table option	read <i>edit</i>		
	T2	Enter number of table value pairs	1 1 to 10		Up to 10 value pairs can be entered in the α table. These are numbered from 1 to 10 and can be edited individually or in sequence.
	T3	Select table value pair	1 1 to number of table value pairs <i>assign</i>		The function chain T3 to T5 will run through as many times as correspond to the value in T2. "Assign" appears as the last step. After confirmation, the system jumps to T6.
	T4	Enter temperature value	0.0 °C -35.0 to 250.0 °C		The temperature values must have a minimum distance of 1 K. Factory setting for temperature value of value pairs in table: 0.0 °C; 10.0 °C; 20.0 °C; 30.0 °C ...
	T5	Enter temperature coefficient α	2.10 %/K 0.00 to 20.00 %/K		
	T6	Message, whether or not the table status is ok	yes <i>no</i>		Only display If status = "no", then set table correctly (all previous settings are kept) or back to measurement mode (this makes the table invalid)

6.4.9 Concentration measurement

You need the Plus Package to use the function group "CONCENTRATION".

The transmitter can convert conductivity values to concentration values. For this, set the operating mode to Concentration measurement (see field A1).

Then, you must enter the basic data to which the concentration calculation should refer.

You require the conductivity characteristics of the medium. To get the characteristics, you can either refer to the data sheets of the medium or determine the characteristics yourself.

1. To do so, create samples of the medium with the concentrations occurring in your process.
2. Measure the uncompensated conductivity of these samples at temperatures which likewise occur in your process.
 - For variable process temperature:

If the variable process temperature should be taken into account for concentration measurement, you must measure the conductivity of each created sample at two different temperatures at least (ideally at the lowest and highest process temperature). The temperature values for the various samples must be identical. However, the difference between the temperatures must be at least 0.5 °C. At least two differently concentrated samples measured at two different temperatures are required because the transmitter needs a minimum of four references.
 - For constant process temperature:

Measure the differently concentrated samples at this constant process temperature. A minimum of two samples is necessary.

Finally, you should have measuring data which are similar to those shown in the following figures:

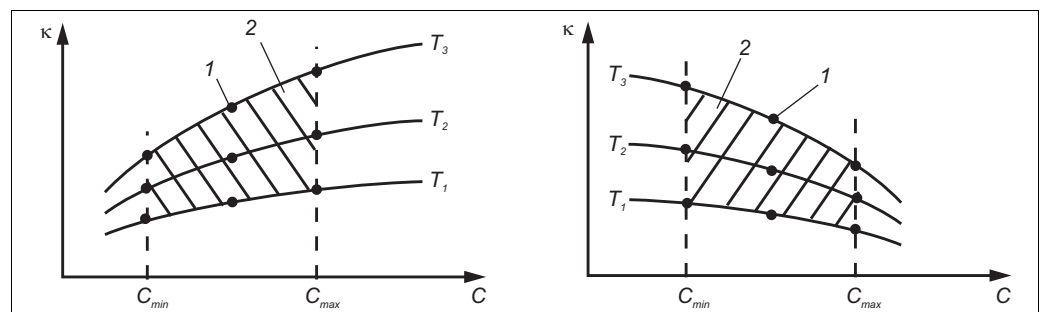

Fig. 35: Measured data for variable process temperatures (example)

κ	Conductivity	1	Measuring point
C	Concentration	2	Measuring range
T	Temperature		

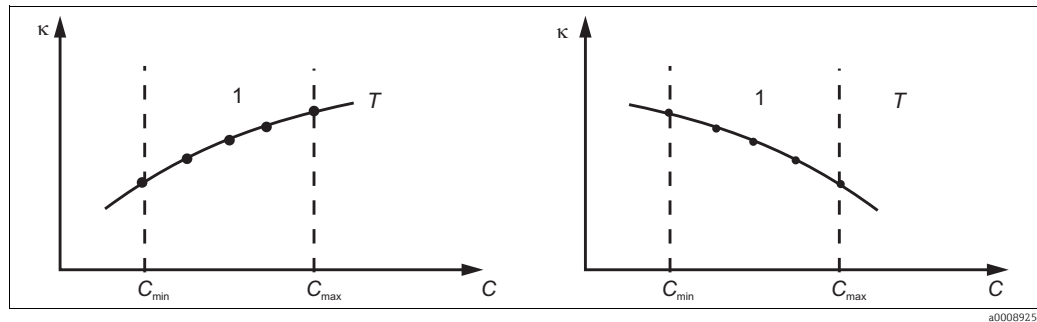

Fig. 36: Measured data for a constant process temperature (example)

κ Conductivity

C Concentration

T Constant temperature

1 Measuring range

The characteristics received from the measuring points must be strictly monotonously increasing or strictly monotonously decreasing in the range of the process conditions. Therefore, neither maxima / minima nor ranges with a constant behaviour can occur. Curve profiles such as those in Fig. 37 are not permitted.

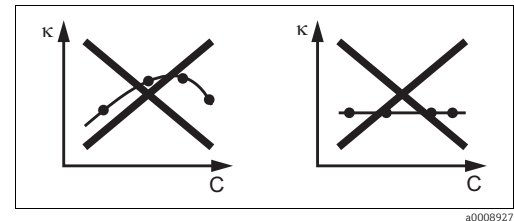

Fig. 37: Impermissible curve profiles

κ Conductivity

C Concentration

Value entry

Enter the three characteristic values for each measured sample in the fields K6 to K8 (value triplets of uncompensated conductivity, temperature and concentration).

- Variable process temperature:
Enter at least four value triplets.
- Constant process temperature:
Enter at least two value triplets.
- Please make sure that the concentrations and temperatures measured for your samples correspond to the measuring range of the process. If the measured values of the process are outside the range of your sample values, this considerably reduces the level of accuracy and the error message E078 or E079 will be displayed.
If you enter an additional value triplet of 0 $\mu\text{S}/\text{cm}$ and 0 % for each temperature used, you can work from the start of measuring range with sufficient accuracy and without an error message.







Enter the values in the order of increasing concentration (see the following example).

mS/cm	%	°C
240	96	60
380	96	90
220	97	60
340	97	90
120	99	60
200	99	90

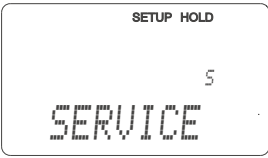
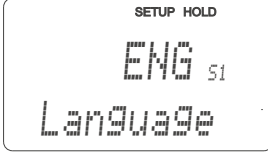
- The setups for temperature compensation in the menu Setup 2 (fields B2 and B3) are inoperative for the concentration measurement. The temperature is already processed by the concentration tables.

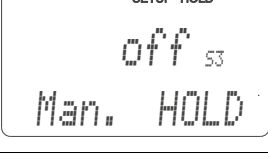
Coding	Field	Selection or range (factory settings bold)	Display	Info
K	Function group CONCENTRATION			Four different concentration fields can be entered in this function group.
K1	<i>Selection of concentration curve, to be used to calculate the display value</i>	1 1 to 4		The curves are independent of each other. Therefore, four different curves can be defined.
K2	<i>Selection of table to be edited</i>	1 1 to 4		When editing a curve, another curve should be used to calculate the corresponding values. Example: When editing curve 2, either curve 1, curve 3 or curve 4 should be active (see K1).
K3	<i>Select table option</i>	read edit		This selection applies to all concentration curves.
K4	<i>Enter number of reference triplets</i>	1 1 to 10		Each triplet consists of three numeric values.
K5	<i>Select triplet</i>	1 1 to number of triplets in K4 assign		Any triplet can be edited. If "assign", go to K9.
K6	<i>Enter uncompensated conductivity</i>	0.0 mS/cm 0.0 to 9999 mS/cm		The function chain K5 to K8 will run through automatically as many times as corresponds to the value in K4. Then the system jumps to K9.
K7	<i>Enter concentration value for K6</i>	0.00 % 0.00 to 99.99 %		Measuring unit selected as in A2. Format selected as in A3.
K8	<i>Enter temperature value for K6</i>	0.0 °C -35.0 to 250.0 °C		
K9	<i>Message whether or not the table status is ok</i>	yes no		Only display If not, then set table correctly (all previous settings are kept) or back to measurement mode (this makes the table invalid).

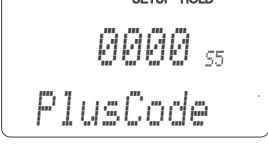
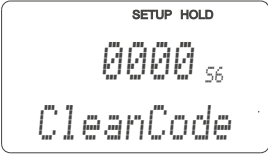
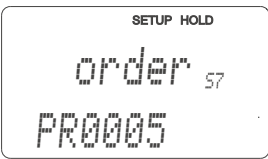
6.4.10 Service

Coding	Field	Setting range (Factory settings, bold)	Display	Info
S	SERVICE function group			Service function settings.
S1	Select language	ENG = English GER = German FRA = French ITA = Italian NL = Dutch ESP = Spanish		This field has to be configured once during device configuration. Then you can exit S1 and continue.
S2	Configure Hold	S+C = Hold during configuration and calibration Cal = Hold during calibration Setup = Hold during configuration None = no Hold		S = setup C = calibration
S3	Manual Hold	Off On		The setting is retained even in the event of a power failure.
S4	Enter Hold dwell period	10 s 0 to 999 s		
S5	Enter SW upgrade release code (Plus Package)	0000 0000 to 9999		The code is located on the nameplate. If an incorrect code is entered, you are taken back to the measurement menu. The number is edited with the PLUS or MINUS key and confirmed with the ENTER key. "1" is displayed if the code is active.
S6	Enter SW upgrade release code Chemoclean	0000 0000 to 9999		The code is located on the nameplate. If an incorrect code is entered, you are taken back to the measurement menu. The number is edited with the PLUS or MINUS key and confirmed with the ENTER key. "1" is displayed if the code is active.
S7	Order number is displayed			If the device is upgraded, the order code is not automatically adjusted.
S8	Serial number is displayed			

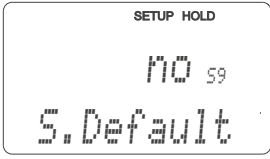
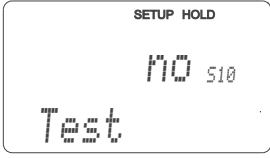
Coding	Field	Setting range (Factory settings, bold)	Display	Info
S9	Reset the device to the basic settings 	No Sens = sensor data Facy = factory settings		Sens = last calibration is deleted and is reset to factory setting. Facy = all data (apart from A1 a. S1) are deleted and reset to the factory setting!
S10	Perform device test	No Displ = display test		

6.4.11 E+H Service

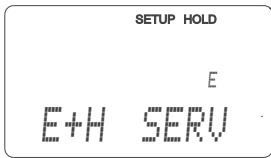
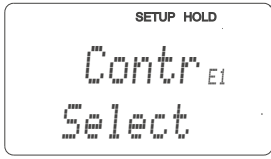
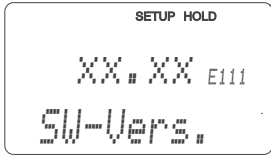
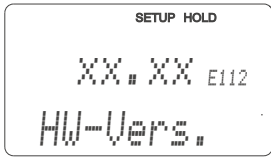
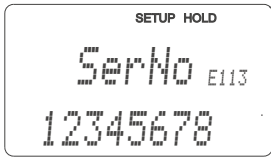
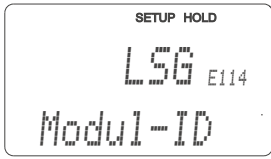
Coding	Field	Setting range (Factory settings, bold)	Display	Note
E	E+H SERVICE function group			Information on the device version
E1	Select module	Contr = controller (1) Trans = transmitter (2) Main = power unit (3) Rel = relay module (4)		
	E111 E121 E131 E141 E151 Software version is displayed			If E1 = contr: instrument software If E1 = trans, main, rel: module firmware If E1 = sens: sensor software
	E112 E122 E132 E142 E152 Hardware version is displayed			Only display function
	E113 E123 E133 E143 E153 Serial number is displayed			Only display function
	E114 E124 E134 E144 E154 Module ID is displayed			Only display function

6.4.12 Interfaces

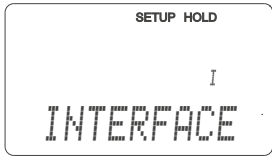
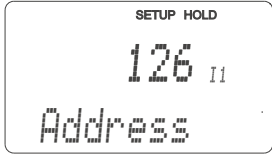
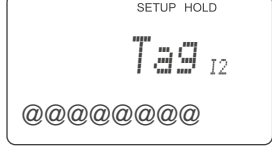
Coding	Field	Setting range (Factory settings, bold)	Display	Info
I	INTERFACE function group			Communication settings (only for device version HART or PROFIBUS).
I1	Enter bus address	Address HART: 0 to 15 or PROFIBUS: 0 to 126		Each address may only be used once in a network. If a device address ≠ 0 is selected, the current output is automatically set to 4 mA and the device is set to multi-drop operation.
I2	Display of measuring point			

6.5 Communication

For devices with a communication interface, please also refer to the separate Operating Instructions BA00208C/07/EN (HART) or BA00209C/07/EN (PROFIBUS).

6.6 Calibration

To access the "Calibration" function group, press the CAL key.

This function group is used to calibrate and adjust the transmitter. Two different types of calibration are possible:

- Calibration by measurement in a calibration solution of a known conductivity.
- Calibration by entering the exact cell constant of the conductivity sensor.

Pay attention to the following:

- At first start-up of inductive sensors, an airset is absolutely required in order for the measuring system to be able to generate accurate measuring values.
- If the calibration procedure is aborted by pressing the PLUS and MINUS keys at the same time (return to C114, C126 or C136) or if the calibration is faulty, then the previous calibration data are reinstated. A calibration error is indicated by the "ERR" message and flashing of the sensor symbol on the display. Repeat calibration!
- The instrument is automatically switched to hold during calibration (factory setting).
- After calibration, the system jumps back to the measuring mode. During the hold dwell period the hold symbol is displayed.
- For conductive sensors only the fields C121 to C126 are relevant.

Basic version does not include functions in *italic*.

Coding	Field	Selection or range (factory settings bold)	Display	Info
C	Function group CALIBRATION			Calibration settings.
C1 (1)	Calibration of inductive sensors with a ring-shaped opening	Airs = Airset (1) Cellc = cell constant (2) InstF = installation factor (3)		When commissioning inductive sensors, an airset is mandatory. The calibration of the sensor is to be performed in air. The sensor must be dry.
Remove sensor from the medium and dry completely .				
C111	Residual coupling start calibration (airset)	current measured value		Start calibration with CAL.
C112	Residual coupling is displayed (airset)	-80.0 to 80.0 µS/cm		Residual coupling of measuring system (sensor and transmitter).

Coding		Field	Selection or range (factory settings bold)	Display	Info
	C113	Calibration status is displayed	o.k. E xxx		If the calibration status is not o.k., the second display line shows an explanation of the error.
	C114	Store calibration results?	yes no new		If C113 = E xxx, then only no or new . If new, return to C. If yes/no, return to "Measurement".
	C1 (2)	Calibration of cell constant	Airs = Airset (1) Cellc = cell constant (2) InstF = installation factor (3)		
<p>Immerse sensor in calibration solution.</p> <p> This describes the calibration for temperature compensated conductivity. For calibration with uncompensated conductivity set the temperature coefficient α to 0.</p>					The sensor should be immersed at a sufficient distance from the vessel wall (installation factor has no influence if $a > 15 \text{ mm} / 0.59''$).
	C121	Enter calibration temperature (MTC)	25 °C -35.0 to 250.0 °C		Only exists if B1 = fixed.
	C122	Enter α value of calibration solution	2.10 %/K 0.00 to 20.00 %/K		This value is specified in the Technical Information of all E+H calibration solutions. You can also use the printed-on table to calculate the value. Set α to 0 for calibration with uncompensated values.
	C123	Enter correct conductivity value of calibration solution	current measured value 0.0 $\mu\text{S/cm}$ to 9999 mS/cm		You should select a value close to the application range.
	C124	Calculated cell constant is displayed	0.0025 to 99.99 cm^{-1}		The calculated cell constant is displayed and entered in A5.
	C125	Calibration status is displayed	o.k. E xxx		If the calibration status is not o.k., the second display line shows an explanation of the error.

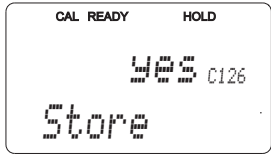
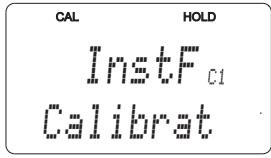
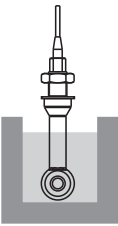
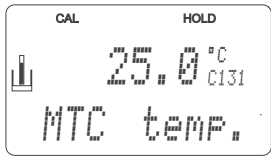
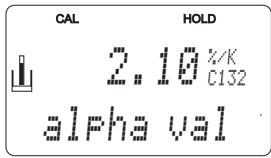
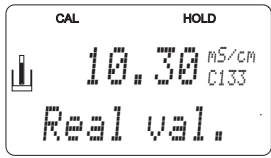
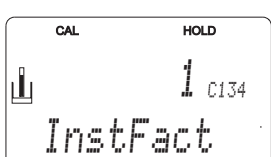
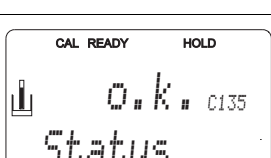
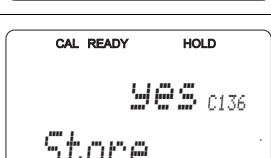
Coding		Field	Selection or range (factory settings bold)	Display	Info
	C126	Store calibration results?	yes no new		If C125 = E xxx, then only no or new . If new, return to C. If yes/no, return to "Measurement".
	C1 (3)	Calibration with sensor adaptation for inductive sensors (Plus Package only)	Airs = Airset (1) Cellc = cell constant (2) InstF = installation factor (3)		Sensor calibration with compensation of wall influence. On inductive sensors, the distance from the sensor to the wall of the pipe and the material of the pipe (conductive or nonconductive) influence the measured value. The installation factor shows this influence. See the technical information of the installed sensor.
The sensor is installed in the process.					
	C131	Enter process temperature (MTC)	25 °C -35.0 to 250.0 °C		Only exists if B1 = fixed.
	C132	Enter α value of the calibration solution	2.10 %/K 0.00 to 20.00 %/K		This value is specified in the TI of all E+H calibration solutions. You can also use the printed-on table to calculate the value. Set α to 0 for calibration with uncompensated values.
	C133	Enter correct conductivity value of the calibration solution	current measured value 0.0 $\mu\text{S}/\text{cm}$ to 9999 mS/cm		You should select a value close to the application range.
	C134	Calculated installation factor is displayed	1 0.10 to 5.00		On inductive sensors, the distance from the sensor to the wall of the pipe and the material of the pipe (conductive or nonconductive) influence the measured value. The installation factor shows this influence. See the technical information of the installed sensor.
	C135	Calibration status is displayed	o.k. E xxx		If the calibration status is not o.k., the second display line shows an explanation of the error.
	C136	Store calibration results?	yes no new		If C135 = E xxx, then only no or new . If new, return to C. If yes/no, return to "Measurement".

7 Diagnostics and troubleshooting

7.1 Troubleshooting instructions

The transmitter constantly monitors its functions itself. If an error occurs which the device recognizes, this is indicated on the display. The error number is shown below the display of the main measured value. If more than one error occurs, you can call these up with the MINUS key.

Refer to the "System error messages" table for the possible error numbers and remedial measures.

Should a malfunction occur without any transmitter error message, please refer to the "Process-specific errors" or the "Device-specific errors" tables to localize and rectify the error. These tables provide you with additional information on any spare parts required.

7.2 System error messages

The system error messages can be called up and selected with the MINUS key.

Error no.	Display	Tests and/or remedial measures	Alarm contact		Error current		Autom. cleaning start		PROFIBUS status	
			Facty	User	Facty	User	Facty	User	PV ¹⁾	Temp
E001	EEPROM memory error	1. Switch device off and then on again.	Yes		No		—	— ²⁾	0C	0C
E002	Instrument not calibrated, calibration data invalid, no user data, user data invalid (EEPROM error), instrument software not suitable to hardware (controller)	2. Load device software compatible with the hardware (with optoscope, see "Optoscope service tool" section). 3. Load measurement-parameter specific device software. 4. If the error persists, send in the device for repair to your local service organisation or replace the device.	Yes		No		—	— ²⁾	0C	0C
E003	Download error	Invalid configuration. Repeat download.	Yes		No		No		0C	0C
E004	Instrument software version not compatible with module hardware version	Load software compatible with hardware. Load measurement-parameter specific device software.	Yes		No		No		0C	0C
E007	Transmitter malfunction, instrument software not compatible with transmitter version		Yes		No		—	— ²⁾	0C	0C
E008	Sensor or sensor connection faulty	Check sensor and sensor connection (Service).	Yes		Yes		No		0C	0C
E010	Temperature sensor defective, not connected or short-circuited (measurement continues with 25 °C)	Check temperature sensor and connections; check device and measuring cable with temperature simulator if necessary. Check correct option selected in field B1.	Yes		No		No		80	0C
E025	Limit for Airset offset exceeded	Repeat Airset (in air) or replace sensor. Dry sensor.	No		No		No		80	80
E036	Calibration range of sensor exceeded	Clean sensor and recalibrate; if necessary, check sensor and connections.	No		No		No		80	80
E037	Below calibration range of sensor		No		No		No		80	80
E045	Calibration aborted	Recalibrate	No		No		—	— ²⁾	80	80

Error no.	Display	Tests and/or remedial measures	Alarm contact		Error current		Autom. cleaning start		PROFIBUS status	
			Facty	User	Facty	User	Facty	User	PV ¹⁾	Temp
E049	Calibration range of installation factor exceeded	Check pipe diameter, clean sensor and recalibrate.	No		No		—	— ²⁾	80	80
E050	Below calibration range of installation factor		No		No		—	— ²⁾	80	80
E055	Below main parameter measuring range	Immerse sensor in conductive medium or perform Airset	Yes		No		No		44	80
E057	Main parameter measuring range exceeded	Check measurement and connections; check device and measuring cable with simulator if necessary.	Yes		No		No		44	80
E059	Below temperature measuring range		Yes		No		No		80	44
E061	Temperature measuring range exceeded		Yes		No		No		80	44
E063	Below current output range 1	Check configuration.	Yes		No		No		80	80
E064	Current output range 1 exceeded	Check measured value and current assignment.	Yes		No		No		80	80
E065	Below current output range 2		Yes		No		No		80	80
E066	Current output range 2 exceeded		Yes		No		No		80	80
E067	Set point exceeded limit contactor 1	Check configuration.	Yes		No		No		80	80
E068	Set point exceeded limit contactor 2		Yes		No		No		80	80
E069	Set point exceeded limit contactor 3		Yes		No		No		80	80
E070	Set point exceeded limit contactor 4		Yes		No		No		80	80
E071	Inaccurate measurement / polarization	Clean sensor; check table; choose suitable sensor	Yes		No		No		44	80
E077	Temperature outside α value table range	Clean sensor; check table.	Yes		No		No		44	80
E078	Temperature outside concentration table		Yes		No		No		44	80
E079	Conductivity outside concentration table		Yes		No		No		44	80
E080	Current output 1 range too small	Increase range in "Current outputs" menu.	Yes		No		—	— ²⁾	80	80
E081	Current output 2 range too small		Yes		No		—	— ²⁾	80	80
E085	Incorrect setting for error current	If the current range "0 to 20 mA" was selected in field O311, the error current "2.4 mA" may not be set.	Yes		No		No	— ²⁾	80	80
E100	Current simulation active		No		No		—	— ²⁾	80	80
E101	Service function yes	Switch off service function or switch device off and then on again.	No		No		—	— ²⁾	80	80
E102	Manual mode active		No		No		—	— ²⁾	80	80
E106	Download yes	Wait for download to finish.	No		No		—	— ²⁾	80	80
E116	Download error	Repeat download.	Yes		No		—	— ²⁾	0C	0C

Error no.	Display	Tests and/or remedial measures	Alarm contact		Error current		Autom. cleaning start		PROFIBUS status	
			Facty	User	Facty	User	Facty	User	PV ¹⁾	Temp
E150	Distance between temp. values in α value table too small or not monotonously increasing	Enter correct values in α value table (minimum distance between temperature values of 1 K required)	Yes		No		No		44	80
E151	USP/EP error		Yes		No		No		44	80
E152	PCS alarm	Check sensor and connection.	Yes		No		No		44	44
E153	USP/EP temperature error		Yes		No		No		80	44
E154	Below lower alarm threshold for period exceeding alarm delay	Perform manual comparison measurement if necessary. Service sensor and recalibrate.	Yes		No		No		.. ³⁾	-
E155	Above upper alarm threshold for period exceeding alarm delay		Yes		No		No		-	-
E156	Actual value undershoots alarm threshold (CC setpoint) for longer than the set permissible maximum period		Yes		No		No		-	-
E157	Actual value exceeds alarm threshold (CC setpoint) for longer than the set permissible maximum period		Yes		No		No		-	-
E162	Dosage stop		Check settings in the CURRENT INPUT and CHECK function groups.	Yes		No		No		-
E171	Flow in main stream too low or zero	Restore flow.	Yes		No		No		-	-
E172	Switch-off limit for current input exceeded	Check process variables at sending measuring instrument. Change range assignment if necessary.	Yes		No		No		-	-
E173	Current input < 4 mA	Check process variables at sending measuring instrument.	Yes		No		No		-	-
E174	Current input > 20 mA	Check process variables at sending measuring instrument. Change range assignment if necessary.	Yes		No		No		-	-

1) PV = Process variable

2) If this error occurs, there is no possibility of starting a cleaning session (field F8 not applicable with this error).

3) Current error messages not applicable via PROFIBUS

7.3 Process specific errors

Use the following table to locate and correct errors.

Error	Possible cause	Tests and / or remedial measures	Equipment, spare parts, personnel
Display deviates from reference measurement	Calibration faulty	Calibrate instrument according to chapter "Calibration".	Calibration solution or sensor certificate
	Sensor soiled	Clean sensor.	See chapter "Cleaning conductivity sensors".
	Incorrect temperature measurement	Check temperature value on instrument and reference unit.	Temperature measuring instrument, precision thermometer
	Incorrect temperature compensation	Check compensation method (none / ATC / MTC) and compensation type (linear/substance/user table).	Please note: transmitter has separate calibration and operating temperature coefficients.
	Reference instrument calibration faulty	Calibrate reference instrument or use calibrated instrument.	Calibration solution, operating instructions of reference instrument
	Incorrect ATC setting on reference instrument	Compensation method and compensation type must be identical on both instruments.	Operating instructions of reference instrument
	Polarization error	Use suitable sensor: <ul style="list-style-type: none"> ▪ Use larger cell constant. ▪ Use graphite instead of stainless steel (check resistance). 	Measuring range tables e.g. in FA "Conductivity" or technical data of conductivity sensors
Incorrect line resistance in field A6	Enter correct value	CYK71: 165 Ω/km	
Implausible measured values in general: <ul style="list-style-type: none"> - continuous measured value overflow - measured value always 000 - measured value too low - measured value too high - measured value frozen - incorrect current output value 	Short circuit / moisture in sensor	Check sensor.	See chapter "Checking inductive conductivity sensors".
	Short circuit in cable or junction box	Check cable and junction box.	See chapter "Checking extension cable and junction box".
	Interruption in sensor	Check sensor.	See chapter "Checking inductive conductivity sensors".
	Interruption in cable or junction box	Check cable and junction box.	See chapter "Checking extension cable and junction box".
	Incorrect cell constant setting	Check cell constant.	Sensor nameplate or certificate
	Incorrect output assignment	Check assignment of measured values to current signals.	
	Incorrect output function	Check 0-20 / 4 -20 mA selection and curve shape (linear /table).	
	Air cushion in assembly	Check assembly and installation.	
	Grounding short on or in device	Measure in insulated container	Plastic container, calibration solutions
	Transmitter module defective	Test with new module.	See chapter "Spare parts".
Impermissible instrument operating state (no response to key actuation)	Switch instrument off and back on.	EMC problem: check grounding and line routing if problem persists or call E+H Service to test.	
Incorrect temperature value	Incorrect sensor connection	Verify connections using connection diagram; three-wire connection mandatory.	Connection diagram in chapter "Electrical connection"
	Measuring cable defective	Check cable for interruption/short circuit/ shunt.	Ohmmeter
	Incorrect temperature sensor type	Select temperature sensor type on instrument (field B1).	

Error	Possible cause	Tests and / or remedial measures	Equipment, spare parts, personnel
Incorrect conductivity measured value in process	No / incorrect temperature compensation	ATC: select compensation type; linear: set correct coefficient. MTC: set process temperature.	
	Incorrect temperature measurement	Check temperature value.	Reference instrument, thermometer
	Bubbles in medium	Suppress bubble formation: – gas bubble trap – counterpressure (cover) – bypass measurement	
	Polarization effects (only with conductive sensors)	Use suitable sensor ▪ Use larger cell constant ▪ Use graphite instead of stainless steel (check resistance)	Measuring range tables e.g. in FA "Conductivity" or technical data of conductivity sensors
	Flow rate too high (may cause bubbles)	Reduce flow or choose low turbulence mounting position.	
	Interference current in medium (only when conductive)	Ground medium close to sensor.	Most frequent cause of currents in medium: defective submerged motors
	Sensor soiled or coated	Clean sensor (see chapter "Cleaning conductivity sensors").	Heavily soiled media: use spray cleaning.
	Incorrect line resistance in field A6	Enter correct value.	CYK71: 165 Ω/km
Measured value fluctuates	Measuring cable interferences	Connect cable screen according to connection diagram.	See chapter "Electrical connection".
	Signal output line interferences	Check line routing, try separate line routing.	Separate routing of signal output and measuring input lines
	Interference currents in medium	Eliminate source of interference or ground medium close to sensor.	
	With conductive sensors: Electromagnetic interferences on signal lines	Use shielded cables and ground the cable shield	
Controller or timer cannot be activated	No relay module available	Install module LSR1-2 or LSR1-4.	
Controller/limit contact does not work	Controller switched off	Activate controller.	See fields R2xx.
	Controller in "Manual/Off" mode	Choose "Auto" or "Manual/On" mode.	Keyboard, REL-key
	Pickup delay setting too long	Disable or shorten pickup delay.	See fields R2xx.
	"Hold" function active	"Automatic Hold" during calibration, "Hold" input activated; "Hold" via keyboard active.	See fields S2 to S5.
Controller/limit contact works continuously	Controller in "Manual/On" mode	Set controller to "Manual/Off" or "Auto".	Keyboard, REL and AUTO keys
	Dropout delay setting too long	Shorten dropout delay.	See field R2xx.
	Control loop interruption	Check measured value, current output, actuators, chemical supply.	
No conductivity current output signal	Line open or short-circuited	Disconnect line and measure directly on instrument.	mA meter 0–20 mA
	Output defective	See chapter "Instrument specific errors".	
Fixed conductivity current output signal	Current simulation active	Switch off simulation.	See field O3.
	Impermissible operating state of processor system	Switch instrument off and back on.	EMC problem: check installation, screen, grounding if problem persists / call E+H Service to test.

Error	Possible cause	Tests and / or remedial measures	Equipment, spare parts, personnel
Incorrect current output signal	Incorrect current assignment	Check current assignment: 0–20 mA or 4–20 mA?	Field O311
	Total load in current loop excessive (> 500 Ω.)	Disconnect output and measure directly on instrument.	mA meter for 0–20 mA DC
	EMC (interference coupling)	Disconnect both output lines and measure directly on instrument.	Use shielded lines, ground screens on both sides, route line in other duct if necessary.
Current output table not accepted	Value interval too small	Select practical intervals	
No temperature output signal	Instrument does not have 2nd current output	Refer to nameplate for variant; change LSCH-x1 module if necessary.	Module LSCH-x2, see chapter "Spare parts".
	Instrument with PROFIBUS PA	PA instrument has no current output!	
Chemoclean function not available	No relay module (LSR1-x) installed or only LSR1-2 available	Install LSR1-4 module. The Chemoclean is enabled using the release code supplied by E+H in the Chemoclean retrofit kit.	Module LSR1-4, see chapter "Spare parts".
Plus package functions not available (Live Check, current curve 2 to 4, alpha value curve 2 to 4, user conc. curve 1 to 4)	Plus package not enabled (enable with code that depends on serial number and is received from E+H with order of extension package)	<ul style="list-style-type: none"> – When upgrading instrument with Plus package: code received from E+H ⇒ enter. – After replacing defective LSCH/LSCP module: first enter instrument serial number (s. nameplate) manually, then enter code. 	For a detailed description, see chapter "Replacement of central module".
No HART communication	No central HART module	Verify by looking at nameplate: HART = -xxx5xx and -xxx6xx	Upgrade to LSCH-H1 / -H2.
	No or wrong DD (device description)	For further information see BA00208C/07/EN, "HART® - Field communication with Liquisys M CxM223/253".	
	HART interface missing		
	Instrument not registered with HART server		
	Load too low (load > 230 Ω required)		
	HART receiver (e.g. FXA 191) not connected via load but via power supply		
	Incorrect device address (addr. = 0 for single operation, addr. > 0 for multi-drop operation)		
	Line capacitance too high		
	Line interferences		
Several devices set to same address	Set addresses correctly.	Communication not possible with several devices set to same address.	

Error	Possible cause	Tests and / or remedial measures	Equipment, spare parts, personnel
No PROFIBUS® communication	No central PA/DP module	Verify by looking at nameplate: PA = -xxx3xx /DP = xxx4xx	Upgrade to LSCP module, see chapter "Spare parts".
	Incorrect instrument software version (without PROFIBUS)	For further information, see BA00209C/07/EN "PROFIBUS PA/DP - Field communication with Liquisys M CxM223/253".	
	Commuwin (CW) II: Incompatible CW II and instrument software versions		
	No or incorrect DD/DLL		
	Incorrect baud rate setting for segment coupler in DPV-1 server		
	Incorrect station (master) addressed or duplicate address		
	Incorrect station (slaves) address		
	Bus line not terminated		
	Line problems (too long, cross section too small; not shielded, screen not grounded, wires not twisted)		
	Bus voltage too low (bus supply voltage typ. 24 V DC for non-Ex)	Voltage at instrument's PA/DP connector must be at least 9 V.	

7.4 Instrument specific errors

The following table helps you during the diagnosis and points to any spare parts required. Depending on the degree of difficulty and the measuring equipment present, diagnosis is carried out by:

- Trained operator personnel
- The user's trained electrical technicians
- Company responsible for system installation/operation
- Endress+Hauser Service

Information on the exact spare part designations and on how to install these parts can be found in the "Spare parts" section.

Error	Possible cause	Tests and/or remedial measures	Execution, tools, spare parts
Device cannot be operated, display value 9999	Operation locked	Press CAL and MINUS keys simultaneously.	See "Function of keys" section.
Display dark, no light-emitting diode active	No line voltage	Check whether line voltage is present.	Electrical technician/e.g. multimeter
	Supply voltage wrong/too low	Compare actual line voltage and nameplate data.	User (data for energy supply company or multimeter)
	Connection faulty	Terminal not tightened; insulation jammed; wrong terminals used.	Electrical technician
	Device fuse defective	Compare line voltage and the nameplate data and replace fuse.	Electrical technician/suitable fuse; see drawing in "Spare parts" section.
	Power unit defective	Replace power unit, note variant.	On-site diagnosis by Endress+Hauser Service, test module necessary
	Central module defective	Replace central module, note variant.	On-site diagnosis by Endress+Hauser Service, test module necessary
	CLM253: ribbon cable item 310 loose or defective	Check ribbon cable, renew if necessary.	See "Spare parts" section.
Display dark, light-emitting diode active	Central module defective (module: LSCH/LSCP)	Renew central module, note variant.	On-site diagnosis by Endress+Hauser Service, test module necessary
Display is on but – No change in display and/or – Device cannot be operated	Device or module in device not correctly mounted	CLM223: reinstall insert. CLM253: remount display module.	Perform with the aid of the installation drawings in the "Spare parts" section.
	Operating system in unpermitted mode	Switch device off and then on again.	Poss. EMC problem: if this persists, check the installation or have it checked by Endress+Hauser Service.
Device gets hot	Voltage wrong/too high	Compare line voltage and nameplate data.	User, electrical technician
	Power unit defective	Replace power unit.	Diagnosis only by Endress+Hauser Service
Incorrect meas. cond/MΩ and/or temperature	Transmitter module defective (module: MKIC), please first carry out tests and take measures as per the "Process errors without messages" section.	Measuring input test: – Connect resistor in place of conductivity sensor – Resistance 100 Ω at terminals 11/12 + 13 = display 0 °C	If test negative: replace module (note variant). Perform with the aid of the exploded drawings in the "Spare parts" section.
Current output, current value incorrect	Adjustment not correct	Check with installed current simulation, connect mA meter directly to current output.	If simulation value incorrect: adjustment in factory or new module LSCxx required. If simulation value correct: check current loop for load and shunts.
	Load too big		
	Shunt/short to ground in current loop		
	Incorrect mode of operation	Check whether 0–20 mA or 4–20 mA is selected.	
No current output signal	Current output stage defective (module LSCH/LSCP)	Check with installed current simulation, connect mA meter directly to current output.	If test negative: Renew central module LSCH/LSCP (note variant).

Error	Possible cause	Tests and/or remedial measures	Execution, tools, spare parts
No function of additional relay	CLM253: ribbon cable item 320 loose or defective	Check ribbon cable seating, renew cable if required.	See "Spare parts" section.
Only 2 additional relays can be triggered	Relay module LSR1-2 installed with 2 relays	Upgrade to LSR1-4 with 4 relays.	User or Endress+Hauser Service
Additional functions (Plus package) missing	No or incorrect release code used	If retrofitting: check whether the correct serial number was quoted when ordering the Plus package.	Handled by Endress+Hauser Sales
	Incorrect device serial number saved in LSCH/LSCP module	Check whether serial number on the nameplate matches SNR in LSCH/ LSCP (field S 8).	The serial number of the device is definitive for the Plus package.
Additional functions (Plus package and/or Chemoclean) missing after LSCH/LSCP module replaced	Replacement modules LSCH or LSCP have the device serial number 0000 when they leave the factory. The Plus package or Chemoclean are not enabled on leaving the factory.	In the case of LSCH/LSCP with SNR 0000, a device serial number can be entered once in fields E114 to E116. Then enter the release code for the Plus package and/or Chemoclean.	For a detailed description, see "Replacing central module" section.
No HART or PROFIBUS-PA/-DP interface function	Incorrect central module	HART: LSCH-H1 or H2 module, PROFIBUS-PA: LSCP-PA module, PROFIBUS-DP: LSCP-DP module, see field E112.	Replace central module; user or Endress+Hauser Service
	Wrong software	SW version see field E111.	SW can be modified with optoscope.
	Bus problem	Remove some devices and repeat the test.	Contact Endress+Hauser Service.

8 Maintenance

Take all the necessary measures in time to guarantee the operational safety and reliability of the entire measuring system.

Maintenance work at the transmitter comprises:

- Calibration (see "Calibration" section)
- Cleaning of assembly and sensor
- Cable and connection check

When performing any work on the device, bear in mind any potential impact this may have on the process control system or on the process itself.

NOTICE

Electrostatic discharge (ESD)

Risk of damage to electronic components

- ▶ Take personal protective measures to avoid ESD, such as discharging beforehand at PE or permanent grounding with a wrist strap.
- ▶ For your own safety, use only genuine spare parts. With genuine spare parts, the function, accuracy and reliability are also guaranteed after repair.

8.1 Maintenance of the entire measuring point

8.1.1 Cleaning the transmitter

Clean the front of the housing with usual commercial cleaning agents.

In accordance with DIN 42 115, the front is resistant to:

- Ethanol (short periods)
- Diluted acids (max. 2% HCl)
- Diluted bases (max. 3% NaOH)
- Soap-based household cleaners

NOTICE

Prohibited cleaning agents

Damage to the housing surface or housing seal

- ▶ For cleaning purposes, never use concentrated mineral acids or bases.
- ▶ Never use organic cleaners such as benzyl alcohol, methanol, methylene chloride, xylene or concentrated glycerol cleaner.
- ▶ Never use high-pressure steam for cleaning purposes.

8.1.2 Cleaning the conductivity sensors

▲ CAUTION

Chemicals burns to the eyes and skin

- ▶ Wear protective goggles and safety gloves.
- ▶ Clean away splashes on clothes and other objects to prevent any damage.
- ▶ Pay particular attention to the information provided in the safety data sheets for the chemicals used.

Clean away fouling on the sensor as follows depending on the particular type of fouling:

- Oily and greasy films:
Clean with grease remover, e.g. alcohol, acetone, as well as hot water and dishwashing detergent if necessary.
- Lime and metal hydroxide buildup:
Dissolve buildup with diluted hydrochloric acid (3 %) and then rinse thoroughly with plenty of clear water.
- Sulfidic buildup (from flue gas desulfurising or sewage treatment plants):
Use a mixture of hydrochloric acid (3 %) and thiocarbamide (commercially available) and then rinse thoroughly with plenty of clear water.
- Buildup containing proteins (e.g. food industry):
Use a mixture of hydrochloric acid (0.5 %) and pepsin (commercially available) and then rinse thoroughly with plenty of clear water.

8.1.3 Simulation of conductive sensors for device test

Check a measuring device for conductivity by replacing the measuring section and temperature sensor with resistors. Simulation accuracy is dependent on the accuracy of the resistors.

Temperature

The values in the right-hand table are valid, if no temperature offset is set on the transmitter.

With the temperature sensor type Pt 1000, all the resistance values are increased by a factor of 10.

-  Connect the temperature equivalent resistor in a three-line system. To connect decade resistors instead of the conductivity sensor, you can use the "Conductivity Test Adapter" service kit (order no. 51500629).

Pt 100 replacement resistors	
Temperature (°C/°F)	Resistance value
-20/-4	92.13 Ω
-10/14	96.07 Ω
0/32	100.00 Ω
10/50	103.90 Ω
20/68	107.79 Ω
25/77	109.73 Ω
50/122	119.40 Ω
80/176	130.89 Ω
100/212	138.50 Ω
200/392	175.84 Ω

Conductivity

For conductivity, the values in the following table are valid, if the cell constant k is set to the nominal value according to column 2.

Otherwise: Display conductivity [mS/cm] = $k[\text{cm}^{-1}] \cdot 1 / R[\text{k}\Omega]$

Resistance R	Cell constant k	Display for conductivity	Display for $M\Omega$
10 Ω	1 cm^{-1}	100 mS/cm	
	10 cm^{-1}	1000 mS/cm	
100 Ω	0.1 cm^{-1}	1 mS/cm	1 $\text{k}\Omega \cdot \text{cm}$
	1 cm^{-1}	10 mS/cm	
	10 cm^{-1}	100 mS/cm	
1000 Ω	0.1 cm^{-1}	0.1 mS/cm	10 $\text{k}\Omega \cdot \text{cm}$
	1 cm^{-1}	1 mS/cm	
	10 cm^{-1}	10 mS/cm	
10 $\text{k}\Omega$	0.01 cm^{-1}	1 $\mu\text{S}/\text{cm}$	1 $\text{M}\Omega \cdot \text{cm}$
	0.1 cm^{-1}	10 $\mu\text{S}/\text{cm}$	100 $\text{k}\Omega \cdot \text{cm}$
	1 cm^{-1}	100 $\mu\text{S}/\text{cm}$	
	10 cm^{-1}	1 mS/cm	
100 $\text{k}\Omega$	0.01 cm^{-1}	0.1 $\mu\text{S}/\text{cm}$	10 $\text{M}\Omega \cdot \text{cm}$
	0.1 cm^{-1}	1 $\mu\text{S}/\text{cm}$	1 $\text{M}\Omega \cdot \text{cm}$
	1 cm^{-1}	10 $\mu\text{S}/\text{cm}$	
1 $\text{M}\Omega$	0.01 cm^{-1}	0.01 $\mu\text{S}/\text{cm}$	100 $\text{M}\Omega \cdot \text{cm}$
	0.1 cm^{-1}	0.1 $\mu\text{S}/\text{cm}$	10 $\text{M}\Omega \cdot \text{cm}$
	1 cm^{-1}	1 $\mu\text{S}/\text{cm}$	
10 $\text{M}\Omega$	0.01 cm^{-1}	0.001 $\mu\text{S}/\text{cm}$	
	0.1 cm^{-1}	0.01 $\mu\text{S}/\text{cm}$	100 $\text{M}\Omega \cdot \text{cm}$

 The $M\Omega$ measurement is normally used for pure and ultrapure water and therefore is only wise for cell constants where $k = 0.01$ or $k = 0.1 \text{ cm}^{-1}$.three-line system.

8.1.4 Simulation of inductive sensors for device test

The inductive sensor cannot be simulated.

However, the overall system comprising the transmitter and inductive sensor can be checked using equivalent resistances. Note the cell constant ($k_{\text{nominal}} = 1.98 \text{ cm}^{-1}$ for CLS50, $k_{\text{nominal}} = 5.9 \text{ cm}^{-1}$ for CLS52, $k_{\text{nominal}} = 6.3 \text{ cm}^{-1}$ for CLS54).

For an accurate simulation, the actual cell constant (can be read in field C124) is to be used to calculate the display value.

The exact formula depends on the sensor type:

CLS50 and CLS52: Display conductivity [mS/cm] = $k(\text{cm}^{-1}) \cdot 1/R [\text{k}\Omega]$

CLS54: Display conductivity [mS/cm] = $k(\text{cm}^{-1}) \cdot 1/R [\text{k}\Omega] \cdot 1.21$

Values for simulation with CLS50 at 25 °C (77 °F):

Simulation resistance R	Default cell constant k	Conductivity display
2 Ω	1.98 cm ⁻¹	990 mS/cm
10 Ω	1.98 cm ⁻¹	198 mS/cm
100 Ω	1.98 cm ⁻¹	19.8 mS/cm
1 kΩ	1.98 cm ⁻¹	1.98 mS/cm

Values for simulation with CLS54 at 25 °C (77 °F):

Simulation resistance R	Default cell constant k	Conductivity display
10 Ω	6.3 cm ⁻¹	520 mS/cm
26 Ω	6.3 cm ⁻¹	200 mS/cm
100 Ω	6.3 cm ⁻¹	52 mS/cm
260 Ω	6.3 cm ⁻¹	20 mS/cm
2.6 kΩ	6.3 cm ⁻¹	2 mS/cm
26 kΩ	6.3 cm ⁻¹	200 μS/cm
52 kΩ	6.3 cm ⁻¹	100 μS/cm

Conductivity simulation:

Pull a cable through the sensor opening and then connect, e.g. to a decade resistor.

8.1.5 Check of conductive sensors

- Measuring surface connection:
The measuring surfaces are directly connected to the connections of the sensor connector.
Check with ohmmeter at $< 1 \Omega$.
- Measuring surface shunt:
There may not be any shunt between the measuring surfaces.
Check with ohmmeter at $> 20 M\Omega$.
- Temperature sensor shunt:
There may not be any shunt between the measuring surfaces and the temperature sensor.
Check with ohmmeter at $> 20 M\Omega$.
- Temperature sensor:
You can find out the type of the temperature sensor being used by consulting the sensor nameplate. The sensor can be checked at the sensor connector with an ohmmeter:
 - Pt 100 at 25 °C (77 °F) = 109.79 Ω
 - Pt 1000 at 25 °C (77 °F) = 1097.9 Ω
 - NTC 10 k at 25 °C (77 °F) = 10 k Ω
- Connection:
For sensors with a terminal connection (CLS12/13) check the assignment of the terminals for reversals and the tightness of the terminal screws.

8.1.6 Check of inductive sensors

The following specifications apply to the CLS50, CLS52 and CLS54 sensors.
The sensor lines on the instrument or junction box are to be disconnected for all tests described here!

- Testing transmitting and receiving coils
 - Ohmic resistance
CLS50/52: approx. 0.5 to 2 Ω
CLS54: approx. 1 to 3 Ω
 - Inductivity approx. 260 to 500 mH (at 2 kHz)
CLS50: approx. 250 to 450 mH
CLS52/54: approx. 180 to 550 mH
(Measure the white and red coaxial cables, between the inner conductor and screen in both cases.)
- Testing the coil shunt
 - A shunt between the two sensor coils is not allowed. The resistance measured should be $>20 M\Omega$.
 Test with ohmmeter between red coaxial cable and white coaxial cable.
- Testing the temperature sensor
Use the table in chapter "Simulation of inductive sensors for device test" to check the Pt 100 / Pt 1000 in the sensor.
Measure between the green and white wires and between green and yellow. The resistance values should be identical.
- Testing the temperature sensor shunt
 - Shunts between the temperature sensor and the coils are not allowed. Check with ohmmeter for $>20 M\Omega$.
 Measure between the temperature sensor wires (green + white + yellow) and the coils (red and white coaxial cables).

8.1.7 Connecting lines and junction boxes

- Use the methods described in chapters "Simulation of conductive/inductive sensors for device test" to perform a quick functional check from the conductivity sensor (sensor connector) to the measuring instrument via an extension.
Connect the decade resistors simply with the service kit "Conductivity Test Adapter", order no. 51500269.
- Check junction boxes for:
 - Moisture (influence at low conductivity or $M\Omega$ measurement, if necessary dry box, replace seals, insert dehydrating bag)
 - Correct connection of all lines
 - Connection of the outer screens
 - Tightness of the terminal screws

9 Repair

9.1 Spare parts

Spare parts are to be ordered from your sales center responsible. Specify the order numbers listed in the chapter "Spare parts kits".

To be on the safe side, you should **always** specify the following data with your spare part orders:

- Instrument order code (order code)
- Serial number (serial no.)
- Software version where available

Refer to the nameplate for the order code and serial number.

The software version is displayed in the instrument software (see chapter "Instrument configuration") if the instrument processor system is functional.

9.2 Dismantling the panel-mounted instrument

 Please note the effects on the process if the device is taken out of service!

Please refer to the following diagram for the item numbers.

1. Disconnect the terminal block (item 420 b) from the rear of the device to de-energize the device.
2. Then remove the terminal blocks (item 420 a and pos. 430) from the rear of the device. Now you can disassemble the device.
3. Press in the latches of the end frame (item 340) and remove the frame from the rear.
4. Release the special screw (item 400) by turning it counter-clockwise.
5. Remove the entire electronics block from the housing. The modules are only mechanically connected and can be easily separated:
 - Simply remove the processor/display module from the front.
 - Pull out the brackets of the rear plate (item 320) slightly.
 - Now you can remove the side modules.
6. Remove the cond. transmitter (item 240) as follows:
 - Using fine side-cutting pliers, nip off the heads of the synthetic distance holders.
 - Then remove the module from above.

Assembly is the reverse of the disassembly sequence. Tighten the special screw hand-tight without a tool.

If the transmitter is exposed to shocks or vibrations you have to replace the synthetic distance holders.

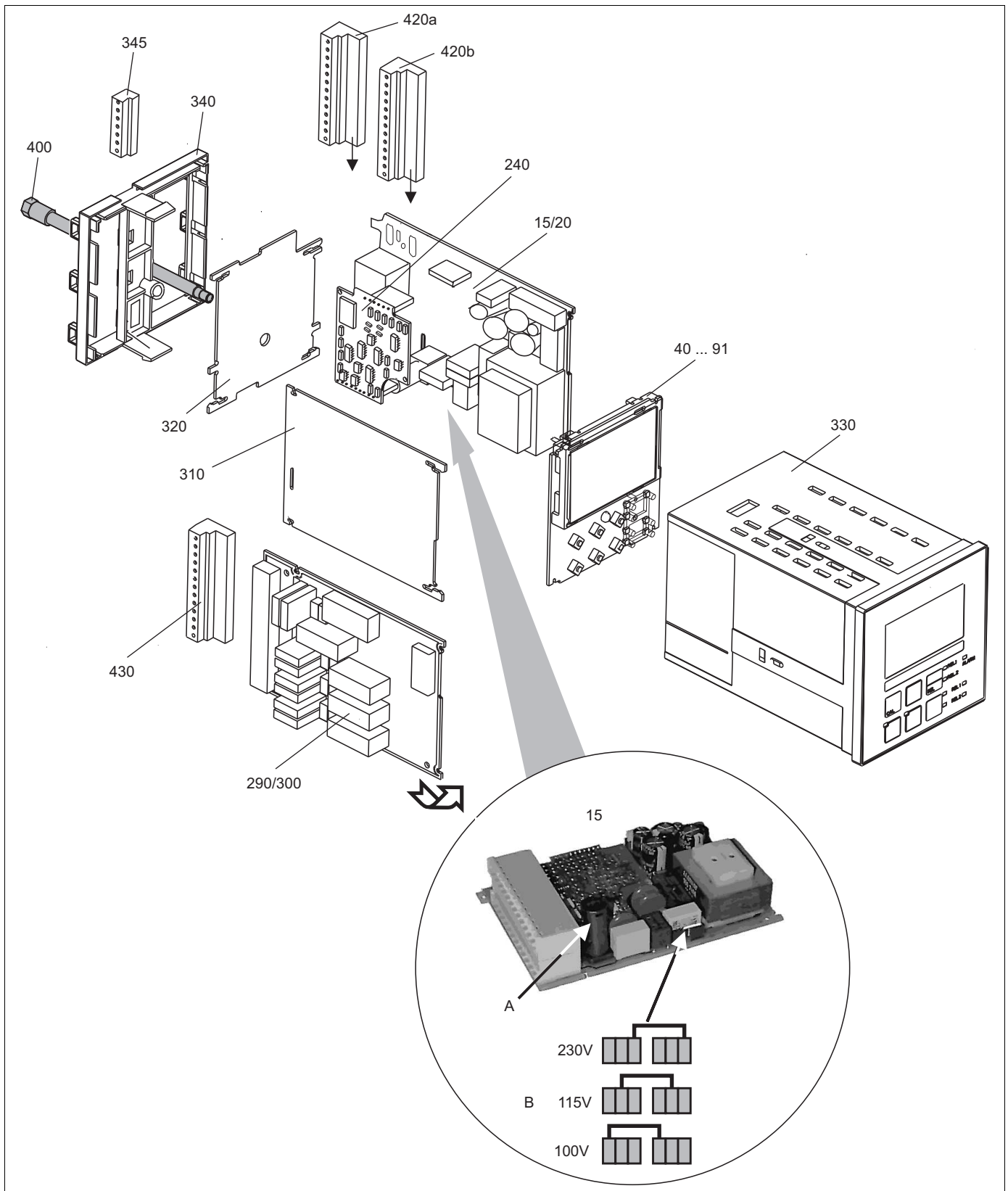



Fig. 38: Exploded view of panel mounted instrument

The exploded drawing contains the components and spare parts of the panel-mounted instrument. You can take the spare parts and the corresponding order number from the following section using the item numbers.

Item	Kit description	Name	Function/contents	Order number
15	Power unit (main module)	LSGA	100 / 115 / 230 V AC	51500317
20	Power unit (main module)	LSGD	24 V AC + DC	51500318
40	Central module cond. (controller)	LSCH-S1	1 current output	51501210
50	Central module cond. (controller)	LSCH-S2	2 current outputs	51501212
60	Central module cond. (controller)	LSCH-H1	1 current output + HART	51501213
70	Central module cond. (controller)	LSCH-H2	2 current outputs + HART	51501214
80	Central module cond. (controller)	LSCP-PA	PROFIBUS PA/no current output	51501215
90	Central module cond. (controller)	LSCP-DP	PROFIBUS DP/no current output	51502502
90	Kit CLM2x3 Central module cond., PROFIBUS DP	LSCP-DP	Central module PROFIBUS DP Relay module + 2 relays Current input and terminals valid of: hardware version 2.10	71134726
41	Central module ind. (controller)	LSCH-S1	1 current output	51501216
51	Central module ind. (controller)	LSCH-S2	2 current outputs	51501218
61	Central module ind. (controller)	LSCH-H1	1 current output + HART	51501219
71	Central module ind. (controller)	LSCH-H2	2 current outputs + HART	51501220
81	Central module ind. (controller)	LSCP-PA	PROFIBUS PA/no current output	51501221
91	Central module ind. (controller)	LSCP-DP	PROFIBUS DP/no current output	51502501
91	Kit CLM2x3 Central module ind., PROFIBUS DP	LSCP-DP	Central module PROFIBUS DP Relay module + 2 relays Current input and terminals valid of: hardware version 2.10	71134727
240	Conductivity transmitter (for use in hazardous areas)	MKIC	Cond. + temperature input	71161137
	Conductivity transmitter	MKIC	Cond. + temperature input	71161133
290	Relay module	LSR1-2	2 relays	51500320
290	Relay module	LSR2-2i	2 relays + current input 4 to 20 mA	51504304
290	Kit CxM2x3 Relay module PROFIBUS DP	LSR2-DP	Relay module + 2 relays Current input and terminals DP valid of: hardware version 2.10	71134732
300	Relay module	LSR1-4	4 relays	51500321
300	Relay module	LSR2-4i	4 relays + current input 4 to 20 mA	51504305
310	Side panel		Kit with 10 parts	51502124
310, 320, 340, 400	Housing mechanical parts		Rear plate, side panel, end frame, special screw	51501076
330, 400	Housing module		Housing with front membrane, sensory tappets, gasket, special screw, tensioning dogs, connection plates and nameplates	51501075
340	End frame PROFIBUS-DP		Rear frame for PROFIBUS DP, with D-submin plug connector	51502513
345	Grounding terminal strip		PE and screening connections	51501086
420a, 420b	Terminal strip set		Complete terminal strip set, standard + HART	51501203

Item	Kit description	Name	Function/contents	Order number
420a, 420b	Terminal strip set		Complete terminal strip set, PROFIBUS PA	51502126
420a, 420b	Terminal strip set		Complete terminal strip set, PROFIBUS DP	51502493
430	Terminal strip		Terminal strip for relay module	51501078
A	Fuse		Part of power unit, item 15	
B	Choice of line voltage		Position of jumper on power unit, item 15 depending on line voltage	

9.3 Dismantling the field instrument

 Please note the effects on the process if the device is taken out of service!

To dismantle the field instrument you need the following tools:

- Standard set of screwdrivers
- Torx-screwdriver size TX 20

Proceed as follows:

1. Open and remove the cover of the connection compartment (item 420).
2. Disconnect the mains terminal (item 470) to de-energize the device.
3. Open the display cover (item 410) and loosen the ribbon cables (item 310/320) on the side of the central module (item 40 ... 91).
4. To remove the central module (item 40), loosen the screw in the display cover (item 450 b).
5. Proceed as follows to remove the electronics box (item 330):
 - Release the screws in the housing base (item 450 a) with two revolutions.
 - Then push the entire box backwards and remove it from above.
 - Make sure that module locks do not open!
 - Loosen the ribbon cables (item 310/320)
 - Bend the module locks out and remove the modules.
6. To remove the docking module (item 340), remove the screws in the housing base (item 450 c) and remove the entire module from above.
7. Proceed as follows to remove the cond. transmitter (item 240):
 - Using fine side-cutting pliers, nip off the heads of the synthetic distance sleeves.
 - Then remove the module from above.

To assemble, carefully push the modules into the trolley tracks of the electronics box and let them engage in the side box noses.

 Incorrect mounting is not possible. Modules inserted in the electronics box incorrectly are not operable since the ribbon cables cannot be connected.
Make sure the cover seals are intact to guarantee IP 65 ingress protection.

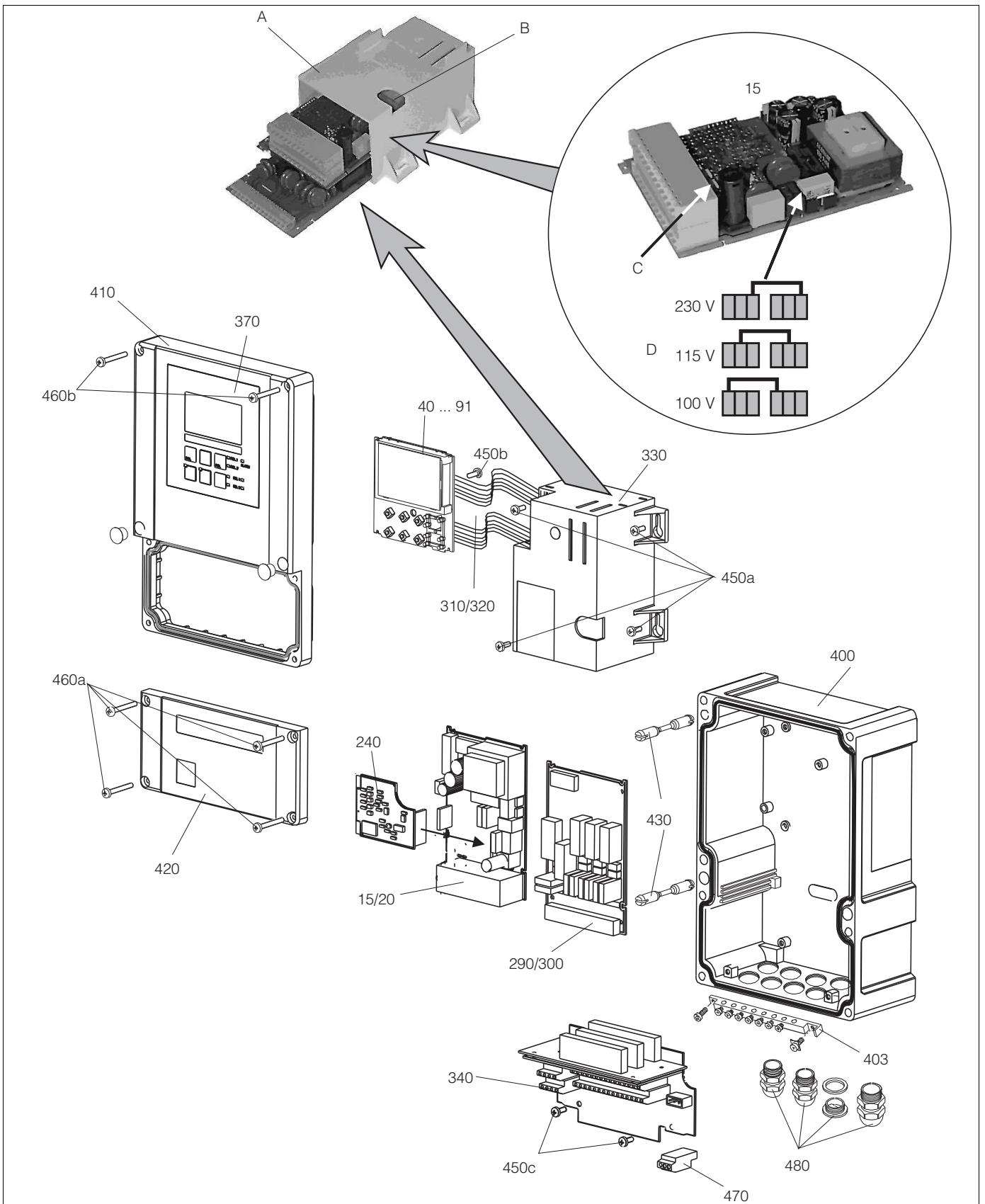

Fig. 39: Exploded drawing of field instrument

The exploded drawing contains the components and spare parts of the field device. You can take the spare parts and the corresponding order number from the following section using the item numbers.

Item	Kit description	Name	Function/contents	Order number
15	Power unit (main module)	LSGA	100 / 115 / 230 V AC	51500317
20	Power unit (main module)	LSGD	24 V AC + DC	51500318
40	Central module cond. (controller)	LSCH-S1	1 current output	51501210
50	Central module cond. (controller)	LSCH-S2	2 current outputs	51501212
60	Central module cond. (controller)	LSCH-H1	1 current output + HART	51501213
70	Central module cond. (controller)	LSCH-H2	2 current outputs + HART	51501214
80	Central module cond. (controller)	LSCP-PA	PROFIBUS PA/no current output	51501215
90	Central module cond. (controller)	LSCP-DP	PROFIBUS DP/no current output	51502502
90	Kit CLM2x3 Central module cond., PROFIBUS DP	LSCP-DP	Central module PROFIBUS DP Relay module + 2 relays Current input and terminals valid of: hardware version 2.10	71134726
41	Central module ind. (controller)	LSCH-S1	1 current output	51501216
51	Central module ind. (controller)	LSCH-S2	2 current outputs	51501218
61	Central module ind. (controller)	LSCH-H1	1 current output + HART	51501219
71	Central module ind. (controller)	LSCH-H2	2 current outputs + HART	51501220
81	Central module ind. (controller)	LSCP-PA	PROFIBUS PA/no current output	51501221
91	Central module ind. (controller)	LSCP-DP	PROFIBUS DP/no current output	51502501
91	Kit CLM2x3 Central module ind., PROFIBUS DP	LSCP-DP	Central module PROFIBUS DP Relay module + 2 relays Current input and terminals valid of: hardware version 2.10	71134727
240	Conductivity transmitter (for use in hazardous areas)	MKIC	Cond. + temperature input	71161137
	Conductivity transmitter	MKIC	Cond. + temperature input	71161133
290	Relay module	LSR1-2	2 relays	51500320
290	Relay module	LSR2-2i	2 relays + current input 4 to 20 mA	51504304
290	Kit CxM2x3 Relay module PROFIBUS DP	LSR2-DP	Relay module + 2 relays Current input and terminals DP valid of: hardware version 2.10	71134732
300	Relay module	LSR1-4	4 relays	51500321
300	Relay module	LSR2-4i	4 relays + current input 4 to 20 mA	51504305
410, 420, 370, 430,	Housing cover		Display cover, connection compartment cover, front membrane, hinges, cover screws, small parts	51501068
400, 480	Housing base		Base, threaded joints	51501072
330, 340, 450	Internal housing parts		Docking assembly, empty electronics box, small parts	51501073
310, 320	Ribbon cable lines		2 ribbon cable lines	51501074
430	Hinges		2 pairs of hinges	51501069
470	Terminal strip		Terminal strip for connection to mains	51501079
420a, 420c	Terminal strip set		Terminal strip set complete for PROFIBUS DP	51502493

Item	Kit description	Name	Function/contents	Order number
403	PE rail		PE connection rail for screen grounding	51501087
A	Electronics box with relay module LSR1-x (bottom) and power unit LSGA/LSGD (top)			
B	Fuse also accessible if electronics box installed			
C	Fuse		Part of power unit, item 15	
D	Choice of line voltage		Position of jumper on power unit, item 10 depending on desired line voltage	

9.4 Replacing the central module

 Generally, when a central module has been replaced, all data which can be changed are set to the factory setting.

Proceed as described below if a central module is replaced:

- If possible, note the customized settings of the device, such as:
 - Calibration data
 - Current assignment, main parameter and temperature
 - Relay function selections
 - Limit value/controller settings
 - Cleaning settings
 - Monitoring functions
 - Interface parameters
- Disassemble the device as explained in the "Dismantling the panel-mounted instrument" or "Dismantling the field instrument" section.
- Use the part number on the central module to check whether the new module has the same part number as the previous module.
- Assemble the device with the new module.
- Start up the device again and check the basic functions (e.g. measured value and temperature display, operation via keyboard).
- Enter the serial number:
 - Read the serial number ("ser-no.") on the nameplate of the device.
 - Enter this number in the fields E115 (year, one-digit), E116 (month, one-digit), E117 (consecutive number, four-digit).
 - In the field E118, the complete number is displayed again so you can check it is correct.

 You can only enter the serial number for new modules with the serial number 0000. This can only be done **once!** For this reason, make sure the number entered is correct before you confirm with ENTER!
Entry of an incorrect code will prevent the additional functions from being enabled. An incorrect serial number can only be corrected at the factory!

Press ENTER to confirm the serial number or cancel the entry to enter the number again.

- If available, enter the release codes for the Plus Package and/or Chemoclean in the "Service" menu.
- Check the Plus Package release (e.g. by opening the function group CHECK / Code P) or the Chemoclean function.
- Make the customer device settings again.

9.5 Return

The device must be returned if repairs or a factory calibration are required, or if the wrong device has been ordered or delivered. According to legal regulations, Endress+Hauser, as an ISO-certified company, is required to follow certain procedures when handling returned products that are in contact with medium.

To ensure swift, safe and professional device returns, please read the return procedures and conditions on the internet site:

www.services.endress.com/return-material

9.6 Disposal

The device contains electronic components and must therefore be disposed of in accordance with regulations on the disposal of electronic waste.

Please observe local regulations.

10 Accessories

10.1 Sensors

Condumax W CLS12

- Conductive conductivity sensor for standard, Ex and high-temperature applications;
- Ordering acc. to product structure, www.products.endress.com/cls12
- Technical Information TI00082C/07/EN

Condumax W CLS13

- Conductive conductivity sensor for standard, Ex and high-temperature applications;
- Ordering acc. to product structure, www.products.endress.com/cls13
- Technical Information TI00083C/07/EN

Condumax W CLS15

- Conductive conductivity sensor for pure and ultra-pure water applications (incl. Ex);
- Ordering acc. to product structure, www.products.endress.com/cls15
- Technical Information TI00109C/07/EN

Condumax H CLS16

- Hygienic conductive conductivity sensor for pure and ultra-pure water applications (incl. Ex);
- Ordering acc. to product structure, www.products.endress.com/cls16
- Technical Information TI00227C/07/EN

Condumax W CLS19

- Conductive conductivity sensor for pure and ultra-pure water applications;
- Ordering acc. to product structure, www.products.endress.com/cls19
- Technical Information TI00110C/07/EN

Condumax W CLS21

- Conductive conductivity sensor for applications with middle to high conductivity (incl. Ex);
- Ordering acc. to product structure, www.products.endress.com/cls21
- Technical Information TI00085C/07/EN

Indumax P CLS50

- Inductive conductivity sensor for standard, Ex and high-temperature applications
- Ordering acc. to product structure, www.products.endress.com/cls50
- Technical Information TI00118C/07/EN

Indumax H CLS52

- Inductive conductivity sensor with short response time for food applications
- Ordering acc. to product structure, www.products.endress.com/cls52
- Technical Information TI00167C/07/EN

Indumax H CLS54

- Inductive conductivity sensor for standard, Ex and in hygienic design for applications in food, beverages, pharmaceuticals and biotechnology
- Ordering acc. to product structure, www.products.endress.com/cls54
- Technical Information TI00400C/07/EN

10.2 Connection accessories

CYK71 measuring cable

- Non-terminated cable for the connection of pH sensors and COS41 oxygen sensor or the extension of sensor cables
- Sold by the meter, order number:
 - non-Ex version, black: 50085333
 - Ex version, blue: 51506616
- Extension cable CLK5
for inductive conductivity sensors, for cable extension via junction box VBM;
(sold by the metre), order no. 50085473

Junction box VBM

- For cable extension
- 10 terminals
- Cable entries: 2 x Pg 13.5 or 2 x NPT ½"
- Material: aluminum
- Ingress protection: IP 65 (≅ NEMA 4X)
- Order numbers:
 - cable entries Pg 13.5: 50003987
 - cable entries NPT ½": 51500177

10.3 Mounting accessories

CYY101 weather protection cover for field devices, absolutely essential if operating the unit outdoors

- Material: stainless steel 1.4031 (AISI 304)
- Order No. CYY101-A

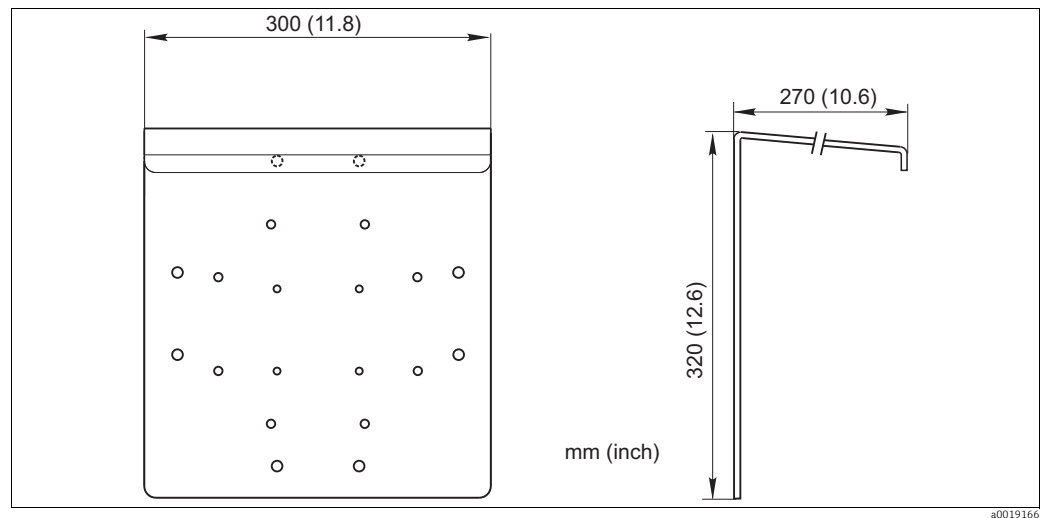

Fig. 40: Weather protection cover for field devices

CYY102 universal post

- Square pipe for mounting transmitters
- Material: stainless steel 1.4301 (AISI 304)
- Order No. CYY102-A

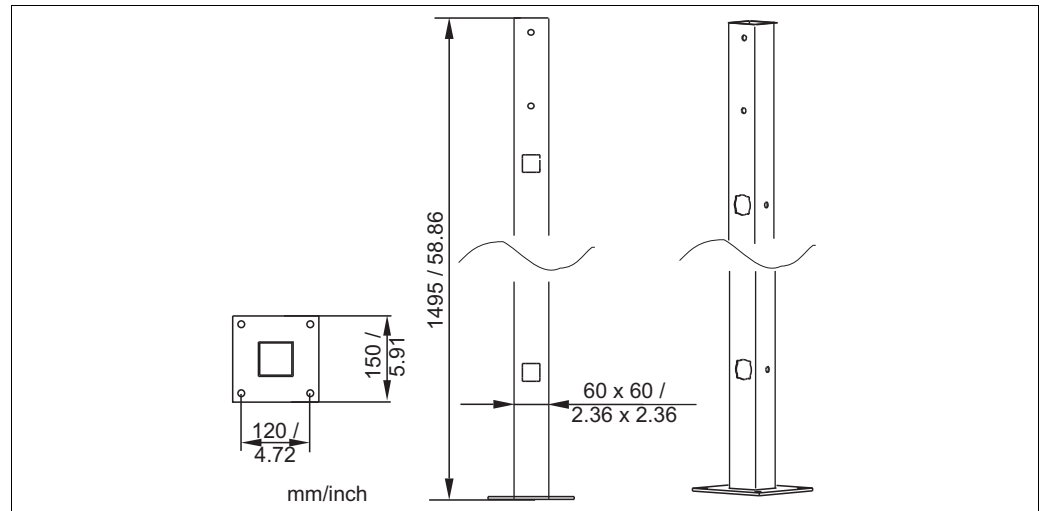

Fig. 41: Universal post

Post mounting kit

- For mounting of field housing on horizontal or vertical pipes (Ø max. 60 mm (2.36"))
- Material: stainless steel 1.4301
- order no. 50086842

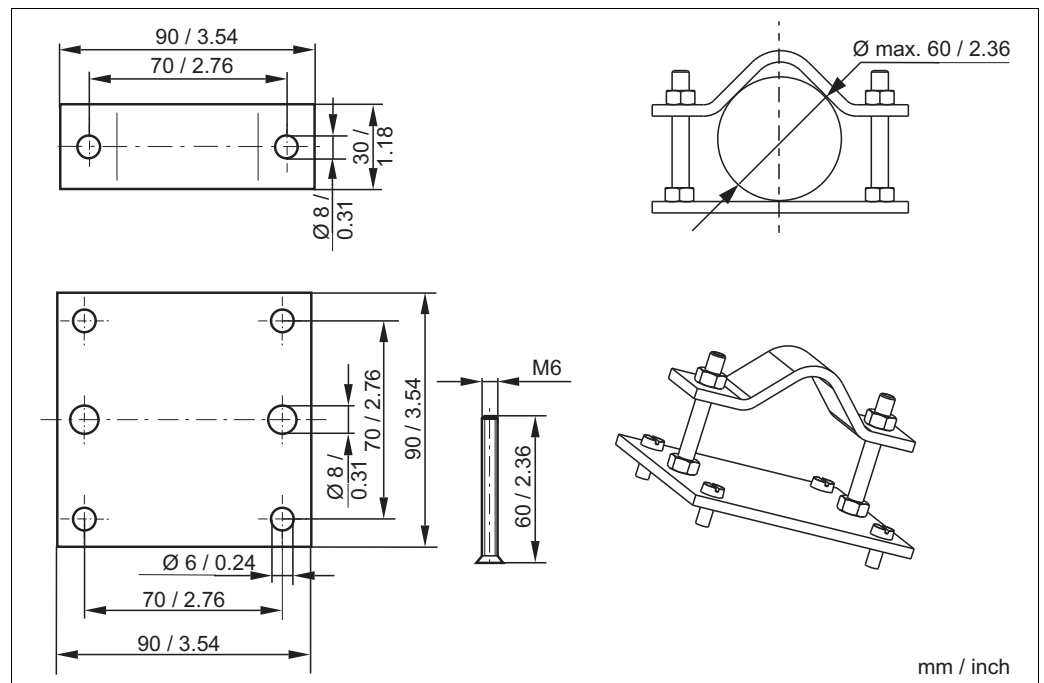

Fig. 42: Post mounting kit

10.4 Software and hardware add-ons

The add-ons can only be ordered by quoting the serial number of the device in question.

- Plus Package
Order no. 51500385
- Chemoclean
Order no. 51500963
- Two-relay card
Order no. 51500320
- Four-relay card
Order no. 51500321
- Two-relay card with current input
Order no. 51504304
- Four-relay card with current input
Order no. 51504305

10.5 Calibration solutions

Precision calibration solutions, acc. to SRM (Standard reference material) of NIST, reference temperature 25 °C (77 °F), with temperature table

- CLY11-A, 74.0 $\mu\text{S}/\text{cm}$, 500 ml (16.9 fl.oz); order no. 50081902
- CLY11-B, 149.6 $\mu\text{S}/\text{cm}$, 500 ml (16.9 fl.oz); order no. 50081903
- CLY11-C, 1.406 mS/cm , 500 ml (16.9 fl.oz); order no. 50081904
- CLY11-D, 12.64 mS/cm , 500 ml (16.9 fl.oz); order no. 50081905
- CLY11-E, 107.0 mS/cm , 500 ml (16.9 fl.oz); order no. 50081906

11 Technical data

11.1 Input

Measured variables	Conductivity, resistivity, temperature	
Measuring range	Conductivity (conductive):	0 to 600 mS/cm (uncompensated)
	Conductivity (inductive):	0 to 2000 mS/cm (uncompensated)
	Resistivity:	0 to 200 M Ω ·cm
	Concentration:	0 to 9999 (% , ppm, mg/l, TDS)
	Temperature:	-35 to +250 °C (-31 to +482 °F)
Cable specification	Cable length (conductive):	conductivity: max. 100 m (328 ft) (CYK71) resistivity: max 15 m (49 ft) (CYK71)
	Cable length (inductive):	max 55 m (180 ft) (CLK5)
	Cable resistance CYK71:	165 Ω /km (conductivity measurement)
	Cable length (conductive):	conductivity: max. 100 m (328 ft) (OYK71) resistivity: max 15 m (49 ft) (OYK71)
	Cable length (inductive):	max 55 m (180 ft) (OLK5)
	Cable resistance OYK71:	165 Ω /km (conductivity measurement)
Cell constant	Adjustable cell constant:	k = 0.0025 to 99.99 cm ⁻¹
Temperature sensors	Pt 100, Pt 1000, NTC 30K	
Measuring frequency	Conductivity, resistivity (conductive):	170 Hz to 2 kHz
	Conductivity (inductive):	2 kHz
Binary inputs	Voltage:	10 to 50 V
	Power consumption:	max. 10 mA
Current input	4 to 20 mA, galvanically separated Load: 260 Ω at 20 mA (voltage drop 5.2 V)	

11.2 Output

Output signal 0/4 to 20 mA, galvanically separated, active

HART	
Signal coding	Frequency Shift Keying (FSK) + 0.5 mA via current output signal
Data transfer rate	1200 Baud
Galvanic isolation	yes

PROFIBUS PA	
Signal coding	Manchester Bus Powered (MBP)
Data transfer rate	31.25 kBit/s, voltage mode
Galvanic isolation	yes (IO-Module)

PROFIBUS DP	
Signal coding	RS485
Data transfer rate	9.6 kBd, 19.2 kBd, 93.75 kBd, 187.5 kBd, 500 kBd, 1.5 MBd
Galvanic isolation	yes (IO-Module)

Signal on alarm 2.4 or 22 mA in case of an error

Load maximum 500 Ω

Linearization transmission behaviour

Conductivity:	adjustable
Resistivity:	adjustable
Concentration:	adjustable
Actuating variable:	adjustable
Temperature:	adjustable

Resolution max. 700 digits/mA

Min. distance for 0 / 4 to 20 mA signal

Conductivity:	
Measured value 0 to 1.999 μS/cm	0.2 μS/cm
Measured value 0 to 19.99 μS/cm	2 μS/cm
Measured value 20 to 199.9 μS/cm	20 μS/cm
Measured value 200 to 1999 μS/cm	200 μS/cm
Measured value 2 to 19.99 mS/cm	2 mS/cm
Measured value 20 to 2000 mS/cm	20 mS/cm
Resistivity	
Measured value 0 to 199.9 kΩcm	20 kΩcm
Measured value 200 to 1999 kΩcm	200 kΩcm
Measured value 2 to 19.99 MΩcm	2.0 MΩcm
Measured value 20 to 200 MΩcm	20 MΩcm
Concentration	no minimum distance
Temperature	15 °C

Isolation voltage max. 350 V_{RMS}/500 V DC

Overvoltage protection	according to EN 61000-4-5	
Auxiliary voltage output	Output voltage:	15 V ± 0.6
	Output current:	max. 10 mA
Contact outputs	Switching current with ohmic load (cos φ = 1): max. 2 A	
	Switching current with inductive load (cos φ = max. 0.4): max. 2 A	
	Switching voltage:	max. 250 V AC, 30 V DC
	Switching power with ohmic load (cos φ = 1):	max. 500 VA AC, 60 W DC
	Switching power with inductive load (cos φ = max. 0.4):	max. 500 VA AC, 60 W DC
Limit contactor	Pickup/dropout delay:	0 to 2000 s
Controller	Function (adjustable):	pulse length/pulse frequency controller
	Controller response:	PID
	Control gain K_p :	0.01 to 20.00
	Integral action time T_n :	0.0 to 999.9 min
	Derivative action time T_v :	0.0 to 999.9 min
	Period for pulse length controller:	0.5 to 999.9 s
	Frequency for pulse frequency controller:	60 to 180 min ⁻¹
	Basic load:	0 to 40% of max. set value
Alarm	Function (selectable):	Latching/momentary contact
	Alarm threshold adjustment range:	Conductivity, resistivity, concentration, temperature, USP, EP: complete measuring range
	Alarm delay:	0 to 2000 s (min)

Protocol specific data

HART	
Manufacturer ID	11 _h
Device type code	0092 _h (ind. measured), 0093 _h (cond. measured)
Transmitter specific revision	0001 _h
HART specification	5.0
DD files	www.products.endress.com/hart
Load HART	250 Ω
Device variables	None (dynamic variables PV, SV, only)
Features supported	-

PROFIBUS PA	
Manufacturer ID	11 _h
Ident number	1515 _h
Device revision	11 _h
Profile version	2.0
GSD files	www.products.endress.com/profibus
GSD file version	
Output values	Main value, temperature value
Input values	Display value of PLC
Features supported	Device locking: The device can be locked by hardware or software.

PROFIBUS DP	
Manufacturer ID	11 _h
Ident number	1521 _h
Profile version	2.0
GSD files	www.products.endress.com/profibus
GSD file version	
Output values	Main value, temperature value
Input values	Display value of PLC
Features supported	Device locking: The device can be locked by hardware or software.

11.3 Power supply

Supply voltage Depending on ordered version:
100/115/230 V AC +10/-15 %, 48 to 62 Hz
24 V AC/DC +20/-15 %

Fieldbus connection

HART	
Supply voltage	n/a, active current outputs
Integrated reverse voltage protection	n/a, active current outputs

PROFIBUS PA	
Supply voltage	9 V to 32 V, max. 35 V
Polarity sensitive	no
FISCO/FNICO compliant acc. to IEC 60079-27	no

PROFIBUS DP	
Supply voltage	9 V to 32 V, max. 35 V
Polarity sensitive	n/a
FISCO/FNICO compliant acc. to IEC 60079-27	no

Power consumption max. 7.5 VA

Mains protection Fine-wire fuse, medium-slow blow 250 V/3.15 A

11.4 Performance characteristics

Reference temperature	25 °C (77 °F); adjustable for the compensation of the medium temperature	
Resolution	Conductivity:	depending on the measuring range: 0.001 µS/cm to 1.999 µS/cm and $k \leq 0.5 \text{ cm}^{-1}$
	Temperature:	0.1 °C
Maximum measured error¹⁾	Conductivity:	
	Display:	max. 0.5 % of measured value ± 4 digits
	Conductivity signal output:	max. 0.75 % of current output range
	Resistivity:	
	Display:	max. 0.5 % of measured value ± 4 digits
	Resistivity signal output:	max. 0.75 % of current output range
	Temperature:	
	Display:	max. 1.0 % of measuring range
	Temperature signal output:	max. 1.25 % of current output range
Repeatability¹⁾	Conductivity:	max. 0.2 % of measured value ± 2 digits
	Resistivity:	max. 0.2 % of measured value ± 2 digits
Temperature compensation	Range:	-35 to +250 °C (-31 to +482 °F)
	Types of compensation:	uncompensated, linear, NaCl, table; conductive only: ultrapure water NaCl, ultrapure water HCl
Temperature offset	±5 °C; for the adjustment of the temperature display	

11.5 Environment

Ambient temperature	-10 to +55 °C (+14 to +131 °F)	
Storage temperature	-25 to +65 °C (-13 to +149 °F)	
Electromagnetic compatibility	Interference emission and interference immunity as per EN 61326-1:2006, EN 61326-2-3:2006	
Ingress protection	Panel mounted instrument:	IP 54 (front), IP 30 (housing)
	Field instrument:	IP 65 / tightness acc. to NEMA 4X
Electrical safety	according EN/IEC 61010-1:2001, Installation Category II, for use up to 2000 m above sea level	
CSA	Apparatus with CSA General Purpose Approval are certified for indoor use.	
Relative humidity	10 to 95%, non-condensing	
Pollution degree	The product is suitable for pollution degree 2.	

1) acc. to IEC 746-1, for nominal operating conditions

11.6 Mechanical construction

Dimensions	Panel mounted instrument:	96 x 96 x 145 mm (3.78 x 3.78 x 5.71 inches) Installation depth: approx. 165 mm (6.50")
	Field instrument:	247 x 170 x 115 mm (9.72 x 6.69 x 4.53 inches)
Weight	Panel mounted instrument:	max. 0.7 kg (1.5 lb)
	Field instrument:	max. 2.3 kg (5.1 lb)
Material	Housing of panel mounted instrument:	Polycarbonate
	Field housing:	ABS PC Fr
	Front membrane:	Polyester, UV-resistant
Terminals	Cross section	max. 2.5 mm ²

12 Appendix

Operating matrix

Function group CALIBRATION C	Calibration InstF = Installation factor C1 (3)	Calibration temperature entry (MTC) 25.0 °C -35.0 ... +250.0 °C C131	Entry of α value of calibration solution 2.10 %/K 0.00 ... 20.00 %/K C132	Entry of correct conductivity value of calibration solution Current meas. value C133 0.0 μ S/cm ... 9999 mS/cm	Display of calculated installation factor 1.0 0.10 ... 5.0 C134	Calibration status is displayed o.k.; E--- C135
	Cellc = Cell constant C1 (2)	Calibration temperature entry (if B1 = fixed) 25.0 °C -35.0 ... +250.0 °C C121	Entry of α value of calibration solution 2.10 %/K 0.00 ... 20.00 %/K C122	Entry of correct conductivity value of calibration solution Current meas. value C123 0.0 mS/cm ... 9999 mS/cm	Display of calculated cell constant 0.0025 ... 99.99 1/cm C124	Calibration status is displayed o.k.; E--- C125
	AirS = Airset C1 (1)	Residual coupling Start calibration Current meas. value C111	Display of residual coupling (Airset) 0.0 μ S C112	Calibration status is displayed o.k.; E--- C113	Store calibration results yes; no; new C114	
MEAS. VALUE DISPLAY with TEMPERATURE DISPLAY in °C	Temperature display in °F	Temperature display suppressed	Measured value display Current output in %	Measured value display Current output in mA	Uncompensated measured value is displayed	
Function group SETUP 1 A	Selection of operation mode cond = conductive ind = inductive MOhm = resistance conc = concentration A1	Selection of unit displayed ppm; mg/l; %; TDS; none (% only if A1 = conc) A2	Display format selection (if A1 = conc) XX.xx; X.xxx; XXX.x; XXXX A3	Selection of unit displayed auto; μ S/cm; mS/cm; S/cm; μ S/m; mS/m; S/m auto Ω ; k Ω -cm; M Ω -cm; k Ω -m (omitted if A1 = conc) A4	Entry of cell constant cond / ind / MOhm 1.000 / 1.98 / 0.01 1/cm 0.0025 ... 99.99 1/cm for cond; ind; MOhm A5	Entry of cable resistance (if A1 = cond) 0.00 Ω 0.00 ... 99.99 Ω A6
Function group SETUP 2 B	Selection of temperature measurement Pt100 Pt1k (= Pt 1000) NTC30 (= NTC 30 k Ω) fixed B1	Selection of temperature compensation type none lin = linear NaCl = common salt Pure = pure water NaCl PureH = pure water HCl Tab = table B2	Entry of α value (if B2 = linear) 2.10 %/K 0.00 ... 20.00 %/K B3	Entry of correct process temperature (if B1 = fixed) 25.0 °C -35.0 °C ... +250.0 °C B4	Temperature sensor calibration (omitted if B1 = fixed) Display of actual value -35.0 ... +250.0 °C B5	Enter temperature difference (omitted if B1 = fixed) Current offset -5.0 ... 5.0 °C B6
Function group CURRENT INPUT Z	Cont. switch-off by current input Off; Input Z1	Delay for cont. switch-off current input 0 s 0 ... 2000 s Z2	Delay for cont. switch-on current input 0 s 0 ... 2000 s Z3	Switch-off limit value for current input 50% 0 ... 100% Z4	Switch-off direction for current input Low; High Z5	Feedforward control to PID controller Off; lin = linear Z6
Function group CURRENT OUTPUT O	Current output selection Out1; Out2 O1	Select measured variable for 2nd current output °C; mS/cm; Contr O2	Characteristic selection table O3 (3)	Table option selection read edit O331	Entry of number of value pairs in table 1 1 ... 10 O332	Selection of value pair in table 1 1 ... number of value pairs assign O333
			sim = simulation O3 (2)	Simulation value entry current value 0 ... 22.00 mA O321		
			lin = linear O3 (1)	Current range selection 4-20 mA; 0-20 mA O311	Entry of 0/4 mA value 0 μ S/cm / 0 k Ω -cm / 0% / 0 °C entire measuring range O312	Entry of 20 mA value 2000 mS/cm / 500 k Ω -cm / 9999 % / 150.0 °C entire measuring range O313
Function group ALARM F	Select contact type Stead = steady contact; Fleet = fleeting contact F1	Select alarm delay unit s; min F2	Alarm delay 0 s (min) 0 s ... 2000 s (min) (depends on F2) F3	Error current setting 22 mA 2.4 mA F4	Error number selection 1 1 ... 255 F5	Set alarm contact to be effective yes; no F6
Function group CHECK P	Switch polarisation detection on or off off; on P1	Set alarm threshold Off; Low; High; Lo+Hi; Lo; Hi; LoHi P2	Enter alarm delay 0 s (min) 0 ... 2000 s (min) P3	Set lower alarm threshold 0 μ S/cm 0 ... 9999 mS/cm P4	Set upper alarm threshold 9999 μ S/cm 0 ... 9999 mS/cm P5	Select process monitoring Off; AC; CC; AC+CC AC; CC; ACCI P6

Store calibration results yes; no; new C136

Store calibration results yes; no; new C126

Entry of measured value damping 1 (no damping) 1 ... 60 A7

Entry of reference temperature 25 °C -35 ... 250 °C B7

Feedforward control = 1 at 50% 0 ... 100% Z7

x value entry (measured value) 0 µS/cm / 0 kΩ·cm / 0 % / 0 °C entire measuring range O334

y value entry (current value) 0.00 mA 0 ... 20.00 mA entire measuring range O235

Table status ok yes; no O236

Field for customer settings

Activate error current for previously set error no; yes F7

Automatic start of cleaning function no; yes (not always displayed, see error messages) F8

Select "next error" or return to menu next = next error; ←-R F9

Set max. perm. period for lower limit exceeded 60 min 0 ... 2000 min P7

Set max. perm. period for upper limit exceeded 120 min 0 ... 2000 min P8

Set monitoring value 1000 µS/cm 0 ... 9999 mS/cm P9

Limit contactor configuration EP PW R2 (7)	Function of R2 (7) Switch off or on Off On R271	Entry of alarm threshold (switch-on point) 80 % 0.0 ... 100.0 % R272	Entry of alarm threshold (switch-on point) 80 % 0.0 ... 100.0 % R262		Pickup delay entry 0 0 ... 2000 s R274	
	USP R2 (6)	Function of R2 (6) Switch off or on Off On R261	Entry of alarm threshold (switch-on point) 80 % 0.0 ... 100.0 % R262	Entry of alarm threshold (switch-on point) 80 % 0.0 ... 100.0 % R262		Pickup delay entry 0 0 ... 2000 s R264
		Clean = Chemoclean (only with rel.3) R2 (5)	Function of R2 (5) Switch off or on Off; On R251	Start pulse selection int = internal ext = external i+ext = internal + external i+stp = internal, suppr. by ext R252	Entry of pre-rinse time 20 s 0 ... 999 s R253	Entry of cleaning time 10 s 0 ... 999 s R254
	Timer R2 (4)		Function of R2 (4) Switch off or on Off; On R241	Rinse time setting 30 s 0 ... 999 s R242	Pause time setting 360 min 1 ... 7200 min R243	Set minimum pause time 120 min 1 ... 3600 min R244
		PID controller R2 (3)	Function of R2 (3) Switch off or on Off; On; Basic; PID+B R231	Entry of set point 0 µS/cm / 0 kΩ·cm / 0 % entire meas. range R232	Entry of gain Kp 1.00 0.01 ... 20.00 R233	Entry of integral action time Tn (0.0 = no I component) 0.0 min 0.0 ... 999.9 min R234
	LC °C = T limit contactor R2 (2)		Function of R2 (2) Switch off or on Off; On R221	Entry of switch-on temperature 250.0 °C -35.0 ... +250.0 °C R222	Entry of switch-off temperature 250.0 °C -35.0 ... +250.0 °C R223	Pickup delay setting 0 s 0 ... 2000 s R224
		LC PV = cond. limit contactor R2 (1)	Function of R2 (1) Switch off or on Off; On R211	Select contact switch-on point 9999 mS/cm / 200 MΩ·cm / 9999 % entire meas. range R212	Select contact switch-off point 9999 mS/cm / 200 MΩ·cm / 9999 % entire meas. range R213	Pickup delay setting 0 s 0 ... 2000 s R214
Function group RELAY R	Select contact to be configured Rel1; Rel2; Rel3; Rel4 R1					
Function group ALPHA TABLE T	Table option selection read edit T1	Entry of number of table value pairs 1 1 ... 10 T2	Selection of table value 1 1 ... number of table value pairs assign T3	Entry of temperature value (x value) 0.0 °C -35.0 ... +250.0 °C T4	Entry of temperature coefficient α (y value) 2.10 %/K 0.00 ... 20.00 %/K T5	Table status o.k. yes; no T6
Function group CONCENTRATION K	Selection of concentration curve for calculation of display value Curve 1 ... 4 K1	Selection of table to be edited 1 1 ... 4 K2	Table option selection read edit K3	Set number of value pairs 1 1 ... 10 K4	Select value pair 1 1 ... number of value pairs in K4 K5	Entry of uncompensated conductivity value 0.0 µS/cm 0.0 ... 9999 mS/cm K6
Function group SERVICE S	Language selection ENG; GER ITA; FRA ESP; NEL S1	Hold configuration - none = no hold - s+c = during setup and calibration - CAL = during calibration - Setup = during setup S2	Manual hold off; on S3	Entry of hold dwell period 10 s 0 ... 999 s S4	Entry of SW upgrade release code (plus package) 0000 0000 ... 9999 S5	Entry of SW upgrade release code Chemoclean 0000 0000 ... 9999 S6
Function group E + H SERVICE E	Module selection Relay E1 (4) MainB = mainboard E1 (3) Trans = transmitter E1 (2) Contr = controller E1 (1)	Software version SW version E141	Hardware version HW version E142	Serial number is displayed E143	Module name is displayed E144	
		Software version SW version E131	Hardware version HW version E132	Serial number is displayed E133	Module name is displayed E134	
		Software version SW version E121	Hardware version HW version E122	Serial number is displayed E123	Module name is displayed E124	
		Software version SW version E111	Hardware version HW version E112	Serial number is displayed E113	Module name is displayed E114	
Function group INTERFACE I	Entry of address HART: 0 ... 15 or Profibus 1 ... 126 I1	Tag description @@@@@@@@ I2				

Dropout delay entry
0 0 ... 2000 s
R275

Dropout delay entry
0 0 ... 2000 s
R265

Entry of post-rinse time	Number of repeat cycles	Set interval between two cleaning cycles (pause time)	Set minimum pause time	Number of cleaning cycles without cleaning agent
20 s 0 ... 999 s	0 0 ... 5	360 min 1 ... 7200 min	120 min 1 ... R357 min	0 0 ... 9
R255	R256	R257	R258	R259

Entry of derivative action time Tv (0.0 = no D component)	Selection of control characteristic	Selection	Entry of pulse interval	Entry of max. pulse frequency	Entry of min. ON time t_{on}	Enter basic load
0.0 min 0.0 ... 999.9 min	dir = direct; inv. = inverted	len = pulse length freq = pulse frequency curr = current input 2	10.0 s 0.5 ... 999.9 s	120 1/min 60 ... 180 1/min	0.3 s 0.1 ... 5.0 s	40% 0 ... 40%
R235	R236	R237	R238	R239	R2310	R2311

Dropout delay setting	Setting of alarm threshold	Display of LC status
0 s 0 ... 2000 s	250.0 °C -35.0 ... +250.0 °C	MAX MIN
R225	R226	R227

Dropout delay setting	Setting of alarm threshold (as an absolute value)	Display of LC status
0 s 0 ... 2000 s	9999 mS/cm / 200 M Ω ·cm / 9999 % entire meas. range	MAX MIN
R215	R216	R217

Entry of associated concentration value	Entry of associated temperature value	Table status o.k.
0.00 % 0 ... 99.99 %	0.0 °C -35.0 ... 250.0 °C	yes; no
K7	K8	K9

Order number is displayed	Serial number is displayed	Reset instrument (restore default values)	Perform instrument test
		no; Sens = sensor data; Facts = factory settings	no; Displ = display
S7	S8	S9	S10

Index

A

Access codes	28
Accessories	95
Calibration solutions	98
Connection	96
Mounting	96
Sensors	95
Software	98
Alarm	46, 101
Alarm contact	21
Ambient temperature	104
Automatic mode	27
Auxiliary voltage output	101

B

Binary inputs	99
---------------	----

C

Cable specification	99
Calibration	69
CE mark	8
Cell constant	99
Central module	93
Check	47
Checking	
Conductive sensors	85
Connections	22
Function	30
Inductive sensors	85
Installation	15
Chemoclean function	53
Cleaning	
Sensors	82
Transmitter	81
Commissioning	30–69
Communication	68
Concentration measurement	63
Connection diagram	17
Contact outputs	101
Controller	101
CSA	104
CSA general purpose	8
Current input	39, 99
Current outputs	42

D

Declaration of conformity	8
Designated use	5
Diagnosis code	72
Dimensions	105
Dismantling	
Field instrument	90
Panel-mounted instrument	87
Display	23
Disposal	94

E

E+H Service	67
Electrical connection	16–21
Electrical icons	6
Electrical safety	104
Electrical symbols	6
Electromagnetic compatibility	5
EMC	104
Environment	104
EP	54
European Pharmacopoeia	54

F

Factory settings	31
Field device connection	18
Fieldbus connection	103
Freezing of outputs	29

H

Hold function	29, 66
---------------	--------

I

Icons	
Electrical	6
Electrical symbols	6
Incoming acceptance	7
Ingress protection	104
Input	99
Installation	9–15
Installation conditions	10
Installation instructions	12–15
Interfaces	68
Isolation voltage	100

K

Key assignment	25
----------------	----

L

Limit contactor	49, 101
Linearization transmission behaviour	100
Load	100
Local operation	27–29

M

Mains protection	103
Maintenance	81
Measuring point	81
Transmitter	81
Manual mode	27
Material	105
Maximum measured error	104
Measured variables	99
Measuring cable	19
Measuring frequency	99
Measuring range	99
Measuring system	9
Mechanical construction	105
Menu	
Alarm	46
Alpha table	62
Calibration	69
Check	47
Concentration	63
Current input	39
Current outputs	42
E+H Service	67
Interfaces	68
Relay	56
Service	66
Setup 1	35
Setup 2	36
Menu structure	29

N

Nameplate	8
-----------	---

O

Operability	23
Operating concept	28
Operation	23
Display	23
Key assignment	25
Operating elements	24
Operational safety	5
Output	100–102
Output signal	100
Overvoltage protection	101

P

P controller	50
PD controller	50
Performance characteristics	104
PI controller	50
PID controller	50
Polarisation detection	47
Pollution degree	104
Post mounting	13
Power consumption	103
Power supply	103
Product safety	6
Protocol specific data	102

Q

Quick	9
Quick commissioning	32
Quick setup	32
Quick start-up	32

R

Reference temperature	104
Relative humidity	104
Relay contact configuration	49
Repeatability1	104
Replacing the central module	93
Requirements for the personnel	5
Resolution	100, 104
Return	94

S

Safety instructions	5–6
Scope of delivery	7
Sensor connection	19
Service	66
Setup 1 (conductivity)	35
Setup 2 (temperature)	36
Signal on alarm	100
Simulation of conductive sensors	82
Simulation of inductive sensors	84
Spare parts	87
Storage temperature	104
Supply voltage	103
Switching on	30
System configuration	35–69

T

Technical data	99–105
Temperature compensation	104
linear	36
NaCl	36
with table	37
Temperature compensation with table	62
Temperature offset	104
Temperature sensors	99
Terminals	105
Timer for cleaning function	53
Troubleshooting	
Instrument specific errors	79
Process specific errors	75
System error messages	72
Troubleshooting instructions	72

U

United States Pharmacopeia	54
USP	54

W

Wall mounting	12
Weight	105
Wiring	16–22
Workplace safety	5



71212629

www.addresses.endress.com
