



Level



Pressure



Flow



Temperature



Liquid
Analysis



Registration



Systems
Components



Services



Solutions

Operating Instructions

Gammapiilot FTG20

Radiometric measuring technology

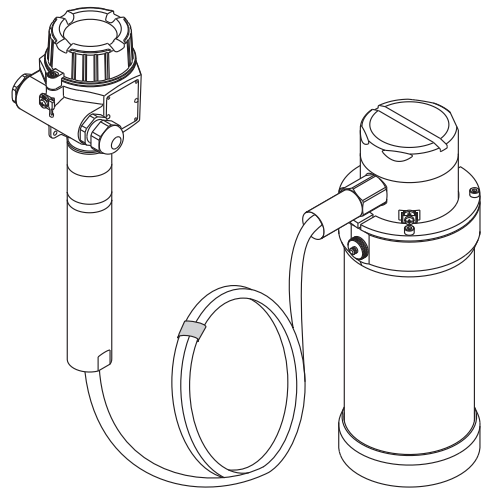
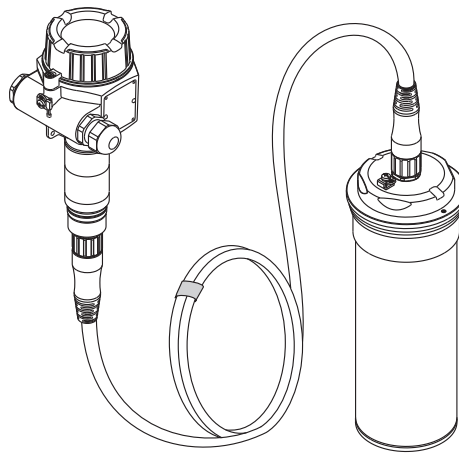

Table of contents

1	Document information	4	10	Diagnostics and troubleshooting	42
1.1	Document function	4	10.1	Meaning of LEDs 1-4 in switch position 3	42
1.2	Symbols used	4	10.2	Error messages	42
1.3	Documentation	6	11	Repair	45
2	Basic safety instructions	8	11.1	General notes	45
2.1	Requirements for the personnel	8	11.2	Spare parts	46
2.2	Designated use	8	11.3	Endress+Hauser services	46
2.3	Workplace safety	8	12	Maintenance	47
2.4	Operational safety	8	12.1	Maintenance tasks	47
2.5	Product safety	9	12.2	Endress+Hauser services	47
3	Product description	10	13	Return	48
3.1	Product design	10	14	Appendix	49
4	Incoming acceptance and product identification	12	14.1	Overview of the operating menu	49
4.1	Incoming acceptance	12	Index	51	
4.2	Product identification	13			
5	Storage and transport	16			
5.1	Storage conditions	16			
5.2	Transporting the product	16			
5.3	Packaging disposal	16			
6	Installation	17			
6.1	Installation conditions	17			
6.2	Mounting the measuring device	18			
7	Electrical connection	24			
7.1	Connection conditions	24			
7.2	Connecting the measuring device	27			
7.3	Post-connection check	30			
7.4	Signal on alarm	30			
8	Operation options	31			
8.1	Access to the operating menu via the local display	31			
8.2	Display and operating elements	31			
9	Commissioning	32			
9.1	Function check	32			
9.2	General information about commissioning	32			
9.3	Commissioning with manual calibration	32			
9.4	Commissioning with automatic calibration	40			
9.5	Performing a total reset	41			
9.6	Record of commissioning	41			





1 Document information

1.1 Document function



These Operating Instructions contain all the information that is required in various phases of the life cycle of the device: from product identification, incoming acceptance and storage, to mounting, connection, operation and commissioning through to troubleshooting, maintenance and disposal.

1.2 Symbols used

1.2.1 Safety symbols

Symbol	Meaning
 <small>A0011189-EN</small>	DANGER! This symbol alerts you to a dangerous situation. Failure to avoid this situation will result in serious or fatal injury.
 <small>A0011190-EN</small>	WARNING! This symbol alerts you to a dangerous situation. Failure to avoid this situation can result in serious or fatal injury.
 <small>A0011191-EN</small>	CAUTION! This symbol alerts you to a dangerous situation. Failure to avoid this situation can result in minor or medium injury.
 <small>A0011192-EN</small>	NOTICE! This symbol contains information on procedures and other facts which do not result in personal injury.



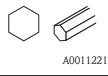

1.2.2 Electrical symbols

Symbol	Meaning
 <small>A0018335</small>	Direct current A terminal to which DC voltage is applied or through which direct current flows.
 <small>A0011198</small>	Alternating current A terminal to which alternating voltage (sine-wave) is applied or through which alternating current flows.
 <small>A0011199</small>	Protective ground connection A terminal which must be connected to ground prior to establishing any other connections.



1.2.3 Tool symbols

Symbol	Meaning
 <small>A0011220</small>	Flat blade screwdriver
 <small>A0011221</small>	Allen key

1.2.4 Symbols for certain types of information

Symbol	Meaning
 A0011182	Permitted Indicates procedures, processes or actions that are permitted.
 A0011184	Forbidden Indicates procedures, processes or actions that are forbidden.
 A0011193	Tip Indicates additional information.
 A0011194	Reference to documentation Refers to the corresponding device documentation.
 A0011195	Reference to page Refers to the corresponding page number.

1.2.5 Symbols in graphics

Symbol	Meaning
1, 2, 3 ...	Item numbers
1., 2., 3. ...	Series of steps
A, B, C, ...	Views
 A0011187	Hazardous area Indicates a hazardous area.
 A0011188	Safe area (non-hazardous area) Indicates the non-hazardous area.

1.3 Documentation

1.3.1 Standard documentation

Document type	Purpose and content of the document
Technical Information TI01023F	Planning aid for your device The document contains all the technical data on the device and provides an overview of the accessories and other products that can be ordered for the device.

 The document types listed are available:
In the Download Area of the Endress+Hauser Internet site: www.endress.com → Download

1.3.2 Documentation

Operating Instructions

Radiation source container	Document
QG2000	BA00223F/00/EN
QG2000 (US version)	BA00370F/00/EN

Technical Information

Device / Device type	Document
FQG60	TI00445F/00/EN
FQG61/62	TI00435F/00/EN
FQG63	TI00446F/00/EN
QG2000	BA00223F/00/EN
QG2000 (US version)	TI00427F/00/EN

Special documentation

Device / Device type	Document	Description
QG2000	SD00142F/00/EN	Supplementary safety instructions for radioactive sources and source containers for use in Canada
FQG60, FQG61, FQG62, FQG63	SD00292F/00/EN	Supplementary safety instructions for radiation source and source containers approved for use in Canada
FQG61, FQG62	SD00293F/00/EN	U.S. General and Specific Licensees for radiation source containers FQG61, FQG62
FQG60, FQG61, FQG62, FQG63	SD00297F/00/A2	Instructions for loading and changing the source / Label set
FQG60, FQG61, FQG62, FQG63	SD00309F/00/A2	Return of source containers
FQG60, FQG61, FQG62, FQG63, QG2000	SD00311F/00/A2	Type A Package
FQG63	SD00313F/00/A2	U.S. General and Specific Licensees for radiation source containers FQG63
FQG60, QG2000	SD00335F/00/EN	U.S. General and Specific Licensees for radiation source containers FQG60
FQG60	SD00343F/00/A2	FQG60 as reference radiation source for minimum point level detection (SIL)

 The document types listed are available:
In the Download Area of the Endress+Hauser Internet site: www.endress.com → Download

1.3.3 Supplementary device-dependent documentation

Safety Instructions (XA) are supplied with the device depending on the approval. These instructions are an integral part of the Operating Instructions.

Feature 010	Approval	Safety instructions
BA	ATEX II 2 G Ex d ia IIC Txx °C	XA00616F/00/A3
BB	ATEX II 2 G Ex d [ia] IIC Txx °C Gb	XA00616F/00/A3
BD	ATEX II 2 D Ex tb ia IIIC Txx °C Db	XA00616F/00/A3
BE	ATEX II 2 D Ex tb [ia] IIIC Txx °C Db	XA00616F/00/A3
CB	CSA/US Ex d ia Cl.I Gr.A-D / Cl.II Gr. E-G / Cl.III, Cl.I, Zone 1 Ex d ia IIC Txx °C	FEG24 = XA00618F/00/EN FEG25 = XA00674F/00/EN
CC	CSA/US Ex d [ia] Cl.I Gr.A-D / Cl.II Gr.E-G / Cl.III, Cl.I, Zone 1 Ex d [ia] IIC Txx °C	FEG24 = XA00618F/00/EN FEG25 = XA00674F/00/EN
IA	IECEX Ex d ia IIC Txx °C Gb	XA00617F/00/EN
IB	IECEX Ex d [ia] IIC Txx °C Gb	XA00617F/00/EN
ID	IECEX Ex tb ia IIIC Txx °C Db	XA00617F/00/EN
IE	IECEX Ex tb (ia) IIIC Txx °C Db	XA00617F/00/EN

 The nameplate provides information on the Safety Instructions (XA) that are relevant for the device.

2 Basic safety instructions

2.1 Requirements for the personnel

The personnel for installation, commissioning, diagnostics and maintenance must fulfill the following requirements:

- ▶ Trained, qualified specialists must have a relevant qualification for this specific function and task
- ▶ Are authorized by the plant owner/operator
- ▶ Are familiar with federal/national regulations
- ▶ Before beginning work, the specialist staff must have read and understood the instructions in the Operating Instructions and supplementary documentation as well as in the certificates (depending on the application)
- ▶ Following instructions and basic conditions

The operating personnel must fulfill the following requirements:

- ▶ Being instructed and authorized according to the requirements of the task by the facility's owner-operator
- ▶ Following the instructions in these Operating Instructions

2.2 Designated use

The Gammapilot FTG20 is designed for non-invasive point level measurement for liquids, solids, suspensions and sludges etc. Used under extreme measuring conditions, e.g. high pressure, high temperature, corrosiveness, toxicity, abrasion.

All kinds of process vessels, e.g.

- Reactors
- Autoclaves
- Separators
- Acid tanks
- Mixers
- Cyclones
- Cupola furnaces

2.3 Workplace safety

For work on and with the device:

- ▶ Wear the required personal protective equipment according to federal/national regulations.

2.4 Operational safety

Risk of injury.

- ▶ Operate the device in proper technical condition and fail-safe condition only.
- ▶ The operator is responsible for interference-free operation of the device.

Conversions to the device

Unauthorized modifications to the device are not permitted and can lead to unforeseeable dangers.

- ▶ If, despite this, modifications are required, consult with the manufacturer.

Repair

To ensure continued operational safety and reliability,

- ▶ Carry out repairs on the device only if they are expressly permitted.
- ▶ Observe federal/national regulations pertaining to repair of an electrical device.
- ▶ Use original spare parts and accessories from the manufacturer only.

Hazardous area

To eliminate a danger for persons or for the facility when the device is used in the hazardous area (e.g. explosion protection, pressure vessel safety):

- ▶ Based on the nameplate, check whether the ordered device is permitted for the intended use in the hazardous area.
- ▶ Observe the specifications in the separate supplementary documentation that is an integral part of these Instructions.

2.5 Product safety

This measuring device is designed in accordance with good engineering practice to meet state-of-the-art safety requirements, has been tested, and left the factory in a condition in which they are safe to operate.

It fulfills general safety requirements and legal requirements. It also conforms to the EC directives listed in the device-specific EC declaration of conformity. Endress+Hauser confirms this fact by applying the CE mark.

3 Product description

3.1 Product design

3.1.1 Components of the FTG20

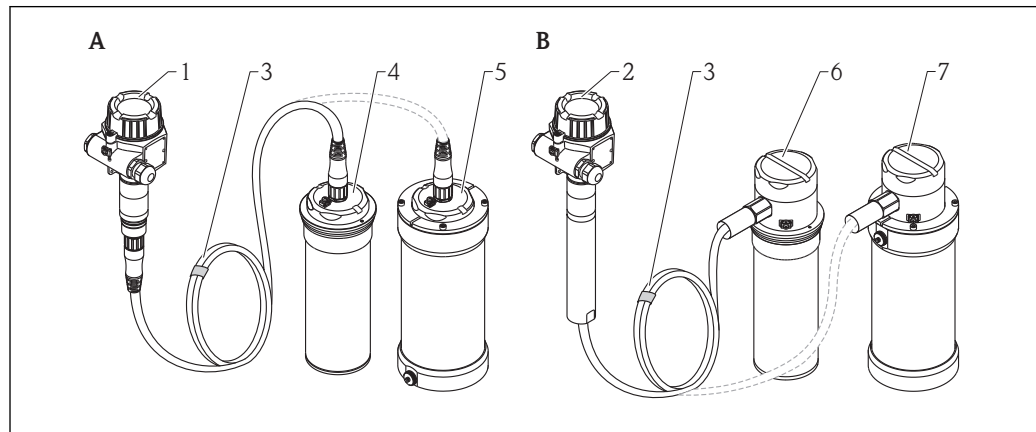

A0016097

- A Standard version*
- 1 Transmitter housing*
- 3 Connecting cable between the transmitter housing and sensor*
- 4 Sensor with Geiger-Müller counters*
- 5 Sensor with Geiger-Müller counters and cooling jacket*
- B Version with impact protection tube and connection compartment for conduiting*
- 2 Transmitter housing with impact protection tube*
- 3 Connecting cable between the transmitter housing and sensor (connecting cable in installations sided tube)*
- 6 Sensor with Geiger-Müller counters and connection compartment*
- 7 Sensor with Geiger-Müller counters, cooling jacket and connection compartment*

3.1.2 Transmitter housing

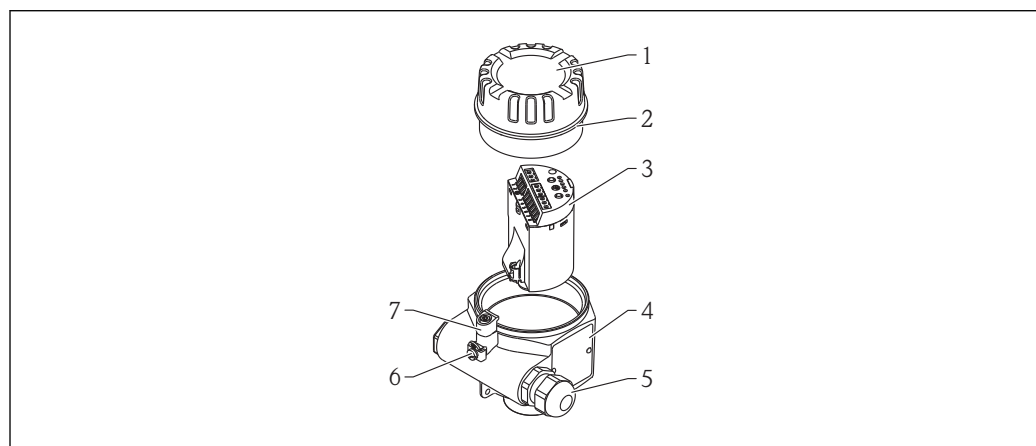

A0016118

- 1 Cover (different depending on the device version)*
- 2 O-ring*
- 3 Electronic insert*
- 4 Nameplate*
- 5 Cable gland (depending on the device version)*
- 6 Ground terminal*
- 7 Cover clamp*

3.1.3 Connecting cable

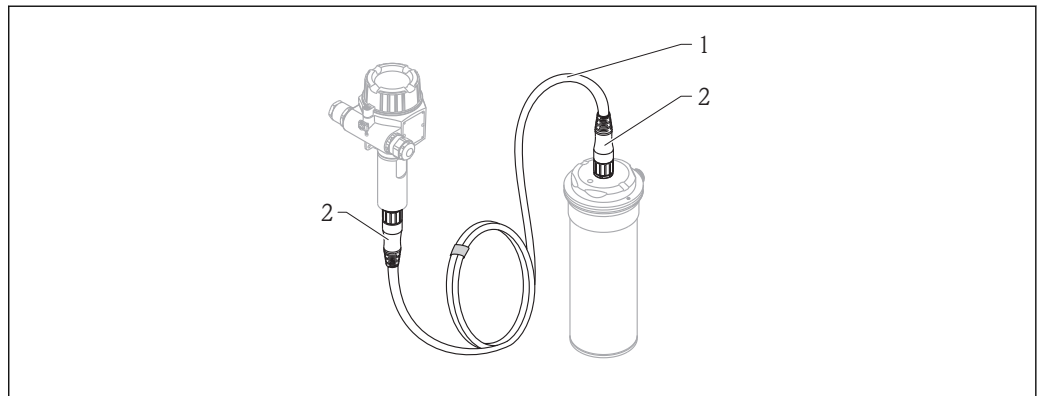

A0016109

- 1 Cable
- 2 M23 Connector

Use of the cables

Description		Usage
Cabel marking	Lapp Ölflex Robust 215C ¹⁾	Transmitter/Sensor Aluminium
	Lapp Ölflex Heat 180 EWKF or Helu Thermflex 180 EWKF-C	Transmitter/Sensor 316L

- 1) Not intended for use in hazardous areas. Use cable only in combination with feature 010 "Approval" option model AA "Non-hazardous area".

3.1.4 Sensor housing

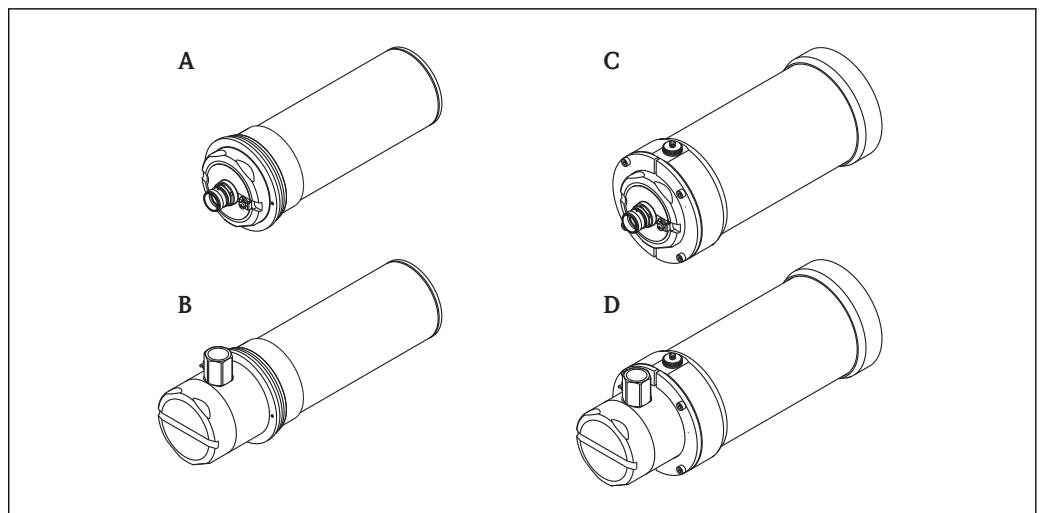

A0016393

- A Sensor with M23 connector
- B Sensor with connection compartment and adapter M20x1.5 - NPT1/2" for conduit
- C Sensor with cooling jacket and M23 connector
- D Sensor with cooling jacket, connection compartment and adapter M20x1.5 - NPT1/2" for conduit

4 Incoming acceptance and product identification

4.1 Incoming acceptance

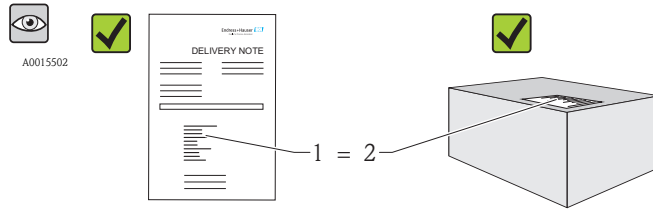

Is the order code on the delivery note (1) identical to the order code on the product sticker (2)?

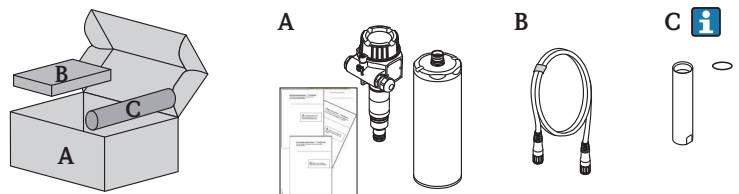

i There is an O-ring in the cardboard roll (C)!

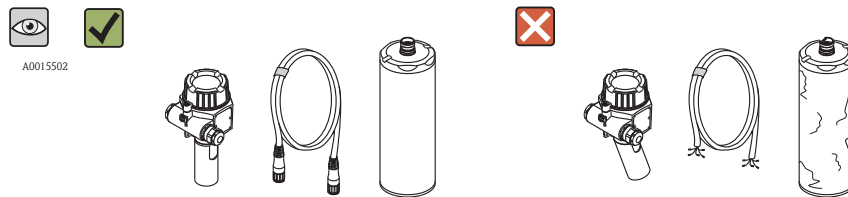

Are the goods undamaged?

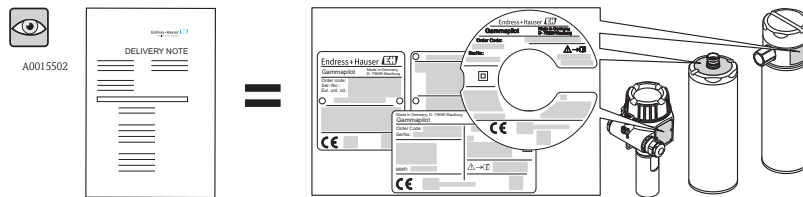

Do the data on the nameplates correspond to the order specifications on the delivery note?

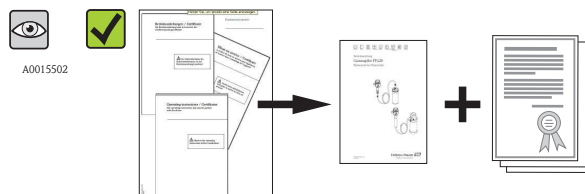

Is the documentation present?

If required (see nameplate): Are the safety instructions (XA) present?

i If one of these conditions is not met, please contact your Endress+Hauser sales office.

4.2 Product identification

The following options are available for identification of the measuring device:

- Nameplate specifications.
- Order code with breakdown of the device features on the delivery note.
- Enter the serial numbers of the nameplates in *W@M Device Viewer*.
(www.endress.com/deviceviewer): All the information about the measuring device is displayed.

For an overview of the scope of the Technical Documentation provided:

Enter the serial numbers of the nameplates in *W@M Device Viewer*. (www.endress.com/deviceviewer)

4.2.1 Transmitter nameplate

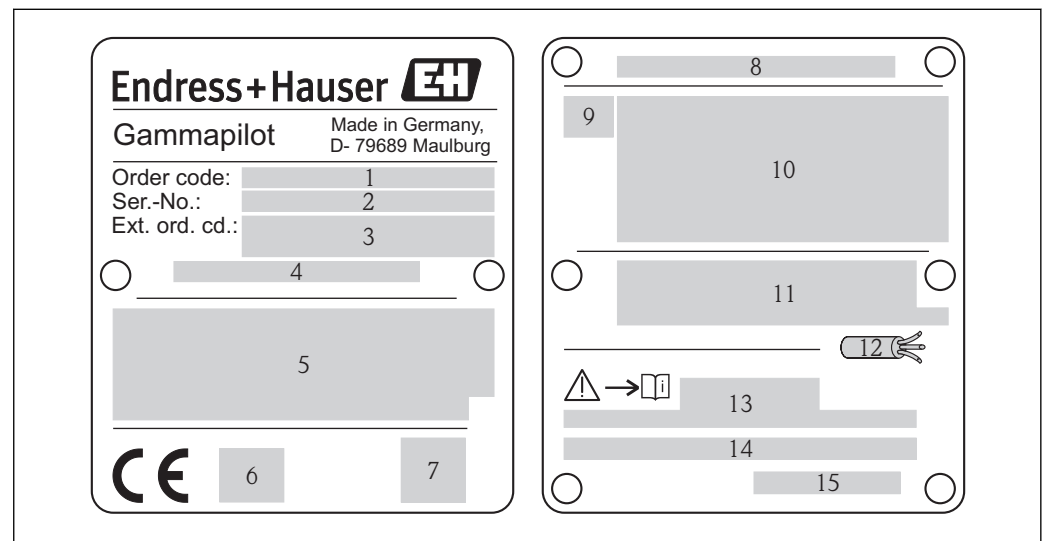

- 1 Order code
- 2 Serial number (Ser. no.)
- 3 Extended order code
- 4 Information about the cable entry
- 5 Information about the electronic insert
- 6 Additional information about the device version
- 7 Data Matrix code
- 8 Degree of protection: e.g. IP, NEMA
- 9 Certificate symbol
- 10 Certificate- and approval-specific data
- 11 Permitted ambient temperature T_a
- 12 Permitted temperature range for cable
- 13 Document number of the safety instructions e.g. XA, ZD, ZE
- 14 Notice text
- 15 Manufacturing date: year-month

A0017489

4.2.2 Sensor nameplate

Sensor with connection compartment

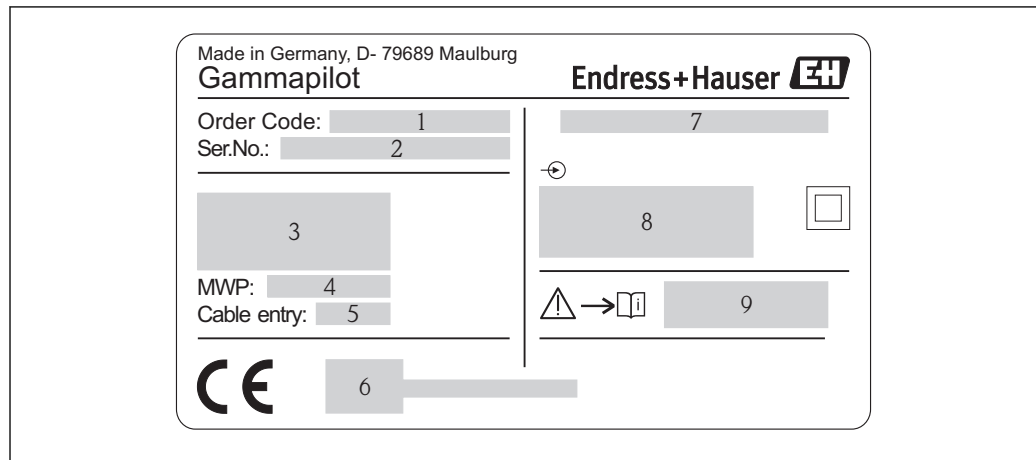

- 1 Order code
- 2 Serial number (Ser. no.)
- 3 Permitted ambient temperature T_a
- 4 Maximum pressure of water cooling (depending on version)
- 5 Information for the cable entry
- 6 Additional information about the device version
- 7 Degree of protection: e.g. IP, NEMA
- 8 Certificate- and approval-specific data
- 9 Document number of the safety instructions e.g. XA, ZD, ZE



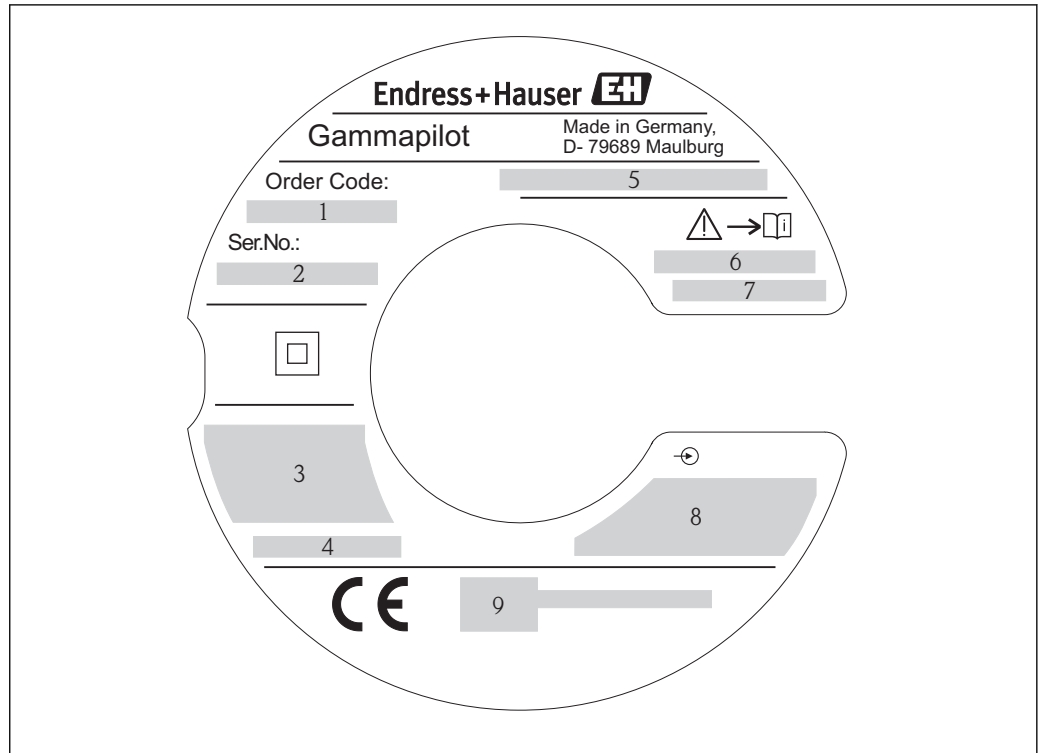

Sensor with M23 connector



A0017554

- 1 Order code
- 2 Serial number (Ser. no.)
- 3 Permitted ambient temperature T_a
- 4 Maximum pressure of water cooling (depending on version)
- 5 Degree of protection: e.g. IP, NEMA
- 6 Notice text
- 7 Document number of the safety instructions e.g. XA, ZD, ZE
- 8 Certificate- and approval-specific data
- 9 Additional information about the device version

4.2.3 Symbols on measuring device

Symbol	Meaning
 A0018360	Warning! This symbol alerts you to a dangerous situation. Failure to avoid this situation can result in serious or fatal injury.
 A0015482	Reference to documentation Refers to the corresponding device documentation.
 A0018363	Input
	Reinforced or double insulation (Class II equipment)

5 Storage and transport

5.1 Storage conditions

–40 to +70 °C (–40 to +158 °F)

⚠ CAUTION

The cooling jacket can become damaged if the cooling water freezes.

- ▶ Empty sensor with cooling jacket or protect against freezing.

5.2 Transporting the product

⚠ WARNING

Risk of device falling if transported incorrectly!

Risk of injury!

- ▶ Transport the measuring device to the measuring point in the original packaging.
- ▶ Never hoist or carry the sensor and transmitter housing by the connecting cable.
- ▶ Follow the safety instructions and transport conditions for devices weighing more than 18 kg (39.6 lbs).

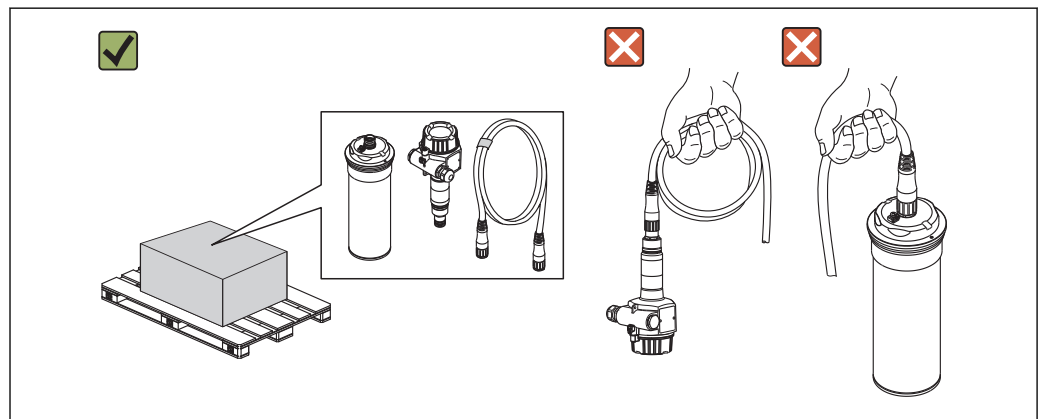

A0016601

5.3 Packaging disposal

All packaging materials are environmentally friendly and 100% recyclable:

- Measuring device secondary packaging:
 - Polymer stretch film that conforms to EC Directive 2002/95/EC (RoHS).
- Packaging:
 - Carton in accordance with European Packaging Directive 94/62/EC; recyclability is confirmed by the affixed RESY symbol.
- Carrying and mounting hardware:
 - Plastic adhesive strips

6 Installation

6.1 Installation conditions

6.1.1 Mounting position

Orientation

- For point level detection, the Gammapilot FTG20 sensor is generally mounted horizontally at the same height as the radiation source container and the required level limit.
- The exit angle of the source container must be exactly aligned to the sensor housing of the Gammapilot FTG20.
- The source container and the sensor housing of the Gammapilot FTG20 must be mounted as close as possible to the vessel. Any access to the beam must be blocked to ensure that it is not possible to reach into this area.
- The Gammapilot FTG20 should be protected against direct sunlight to extend the lifetime. If necessary, use a protective cover.
- The mounting accessory or similar device should be used to secure the Gammapilot FTG20. The mounting device must be installed in such a way as to withstand the weight of the Gammapilot under all anticipated operating conditions.
- The ideal position for the transmitter housing is close to the radiation source container.

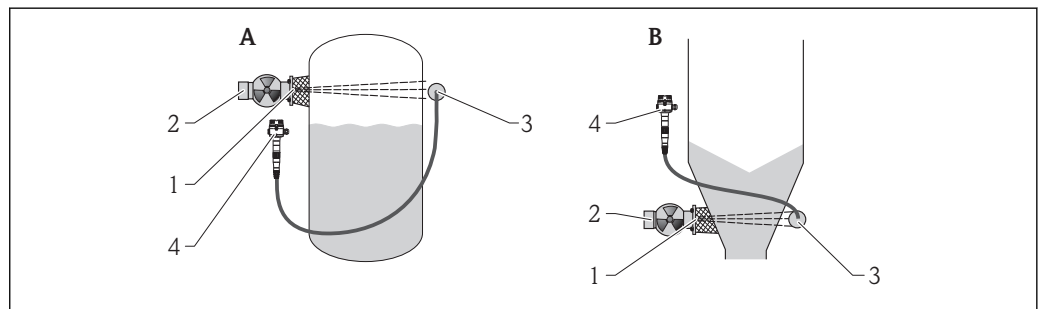

A0015921

- A Maximum point level detection
 B Minimum point level detection
 1 Radiation exit channel
 2 Radiation source container
 3 Gammapilot FTG20, sensor
 4 Gammapilot FTG20, transmitter

6.1.2 Requirements from environment and process

Ambient temperature range

The device version depends on the ambient conditions present.

	Aluminum	316L
At the transmitter housing	-40 to +70 °C (-40 to +158 °F)	-40 to +70 °C (-40 to +158 °F) ¹⁾
At the sensor housing	-40 to +70 °C (-40 to +158 °F)	Without water cooling: -40 to +70 °C (-40 to +158 °F) ¹⁾
		With water cooling: 0 to +120 °C (32 to +248 °F)

1) Note! The lower temperature limit only applies to a permanently installed connecting cable. Minimum temperature during installation: -20 °C (-4 °F)

Vibrations

IEC EN 60068-2-64 (test Fh; 10 to 2 000 Hz, $1(\text{m/s}^2)^2/\text{Hz}$)

6.2 Mounting the measuring device

6.2.1 Required tools

For transmitter

Wall mounting	Pipe mounting
<ul style="list-style-type: none"> ■ Screwdriver ■ Socket or ring wrench SW10 ■ 2 x securing screws M6 	<ul style="list-style-type: none"> ■ Screwdriver ■ Socket or ring wrench SW10

For sensor

Installing the mounting clamps
<ul style="list-style-type: none"> ■ DN80: flat blade screwdriver ■ DN100: flat blade screwdriver

6.2.2 Mounting the measuring device

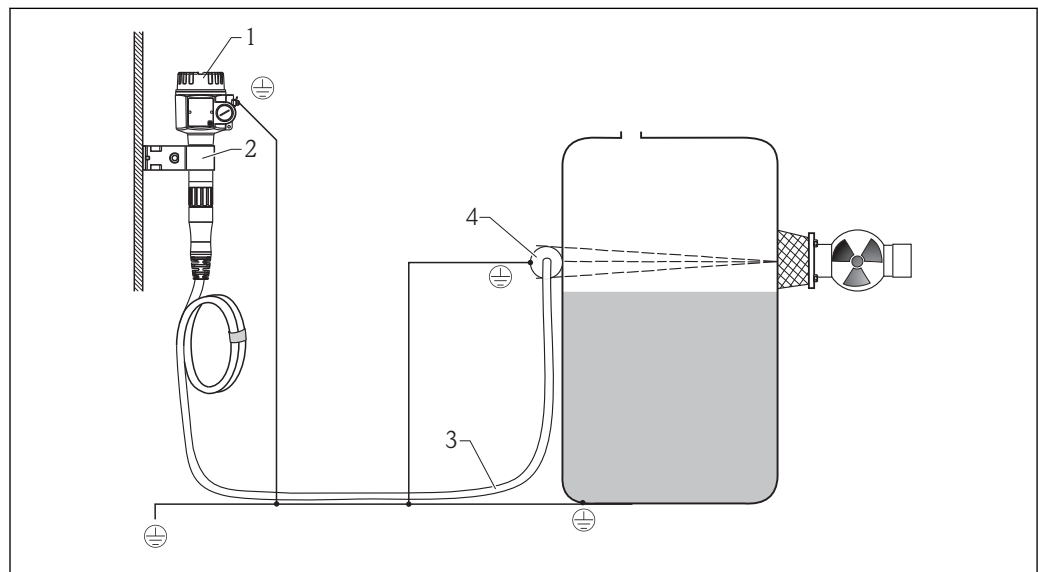

- 1 Transmitter housing
 2 Mounting set for wall and pipe mounting
 3 Connecting cable, 5 m (16 ft), 10 m (33 ft), 20 m (66 ft)
 4 Sensor + 2 mounting clamps

i Please follow the installation instructions from the accompanying "Safety Instructions" when installing in hazardous areas .

6.2.3 Installing the transmitter with the mounting set

- i** ■ The mounting set for wall and pipe mounting can be ordered as an accessory.
- Before using the wall bracket as drilling template, first screw it to the transmitter housing. This reduces the hole spacing.

Wall mounting

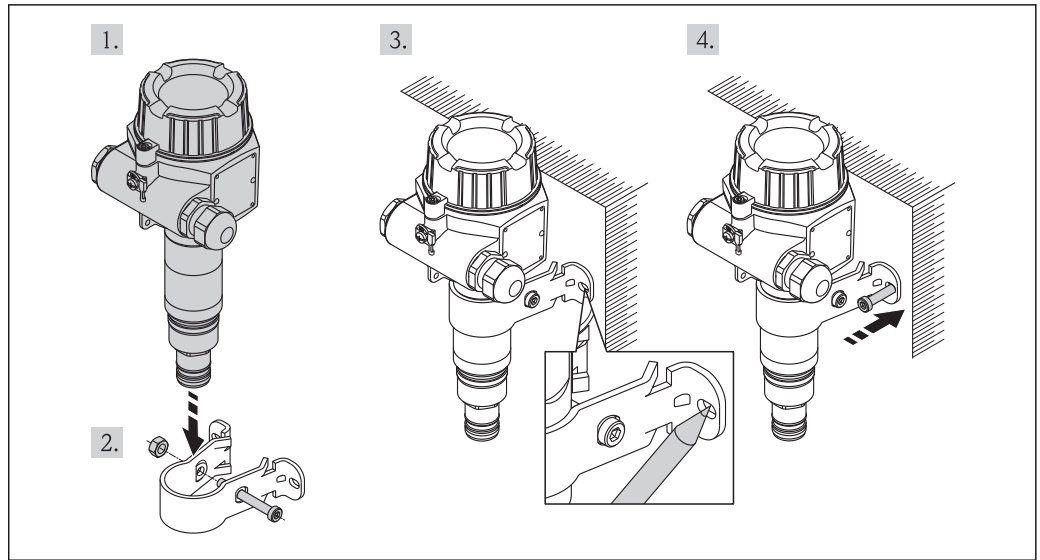

1. Guide the transmitter into the mounting set.
2. Screw in the mounting set.
3. Mark the hole spacing for drilling the holes.
4. Secure the transmitter onto the wall.

Pipe mounting (for pipes up to a max. of 2 ")

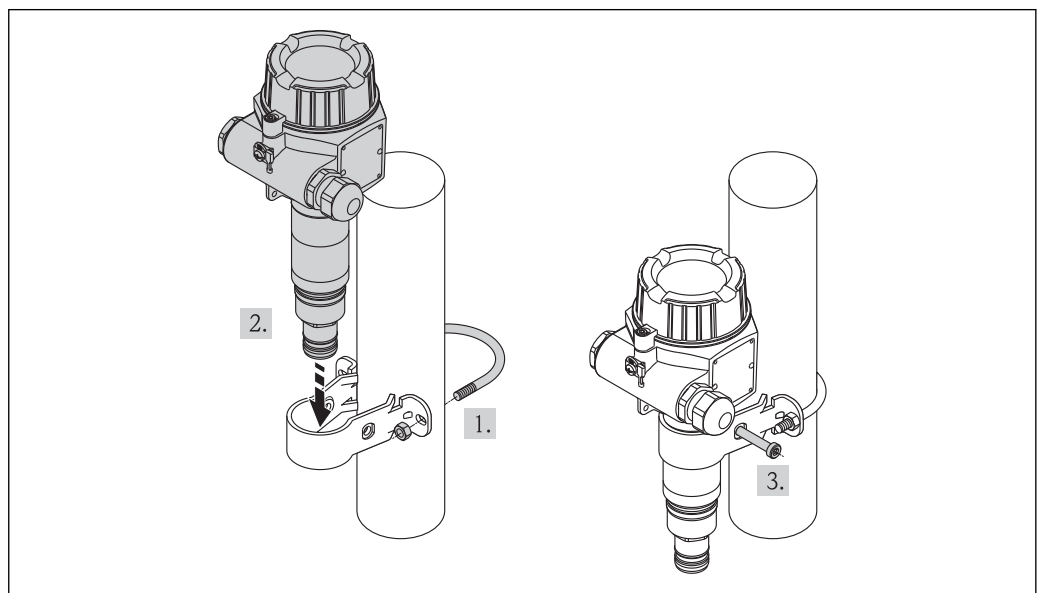

1. Secure the mounting set onto the pipe (max. 2 ").
2. Guide the transmitter into the mounting set.
3. Screw in the mounting set at the transmitter.

6.2.4 Installing the sensor using mounting clamps

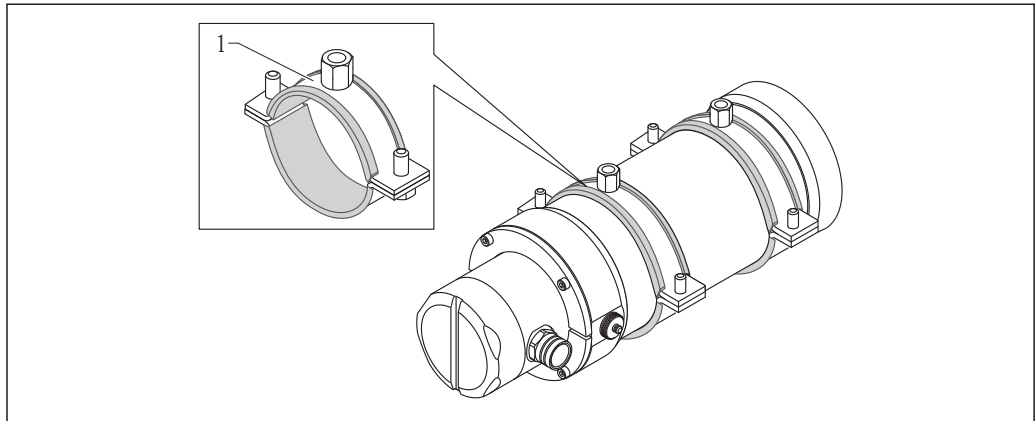

A0017192

1 Mounting clamps

6.2.5 Mounting the cooling jacket

Ambient temperature T_a : $\leq 120\text{ °C}$ (248 °F)

Maximum pressure: 4 bar (58 psi)

Flow temperature	Required flow
Max. 40 °C (104 °F)	0.2 l/min
Max. 50 °C (122 °F)	0.5 l/min

⚠ WARNING

Pressurized water cooling system!

- ▶ Do not open the cylinder screws (see diagram below) when pressurized.

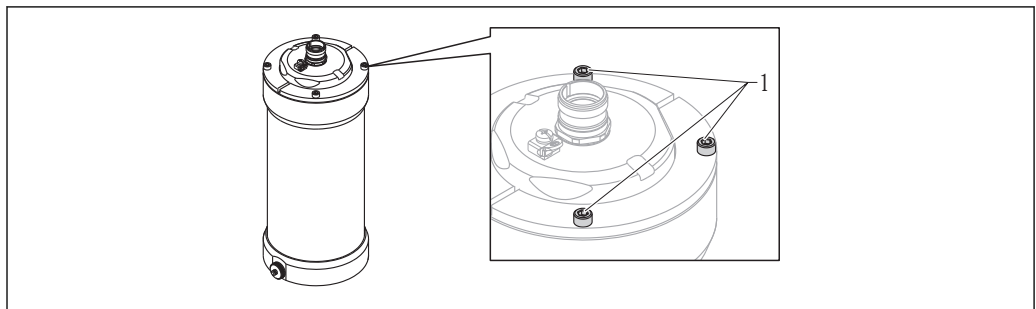

A0017194

1 Cylinder screws

Cooling jacket mounting position

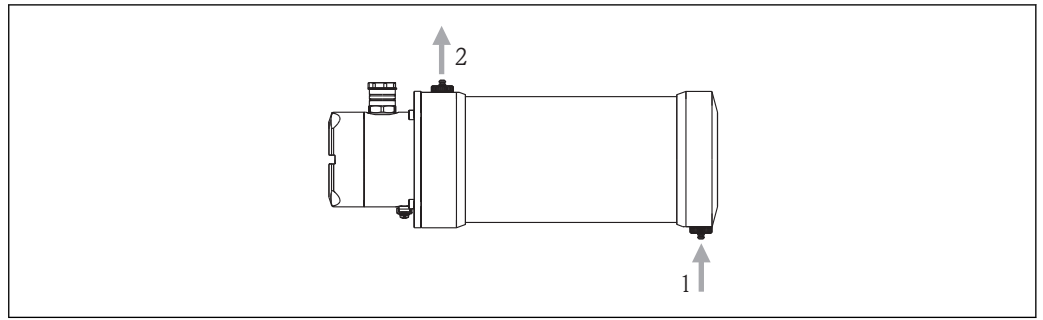

A0019032

 1 Mounting position for point level detection

- 1 Inlet
- 2 Outlet

 The inflow must always be from below so that the cooling jacket is completely full.

6.2.6 Mounting the sensor cable at the transmitter

Standard

- i** Please follow the safety and installation instructions when mounting in hazardous areas .
- Observe allocation of the sensor cable ((→ 11))
- Do not subject the sensor cable to an increased tensile load!

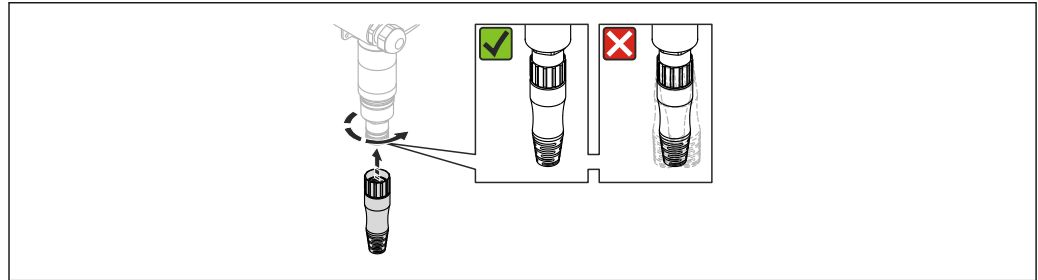

A0016643

- i** Press the connector securely into the bushing and fully tighten the union nut. Do not let the cable connector hang loose.

Version for conduiting (accessories supplied: conduit gland adapter)

- i** Please follow the safety and installation instructions when mounting in hazardous areas .
- Observe allocation of the sensor cable ((→ 11))
- Do not subject the sensor cable to an increased tensile load!

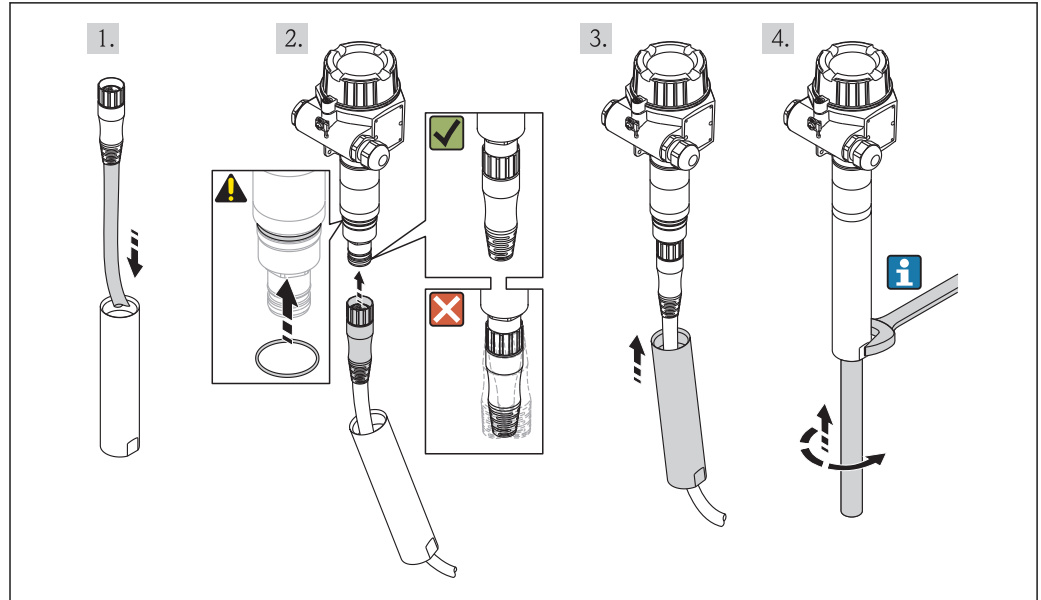

A0017193

1. Push the cable connection through the conduit (impact protection tube + pipe at customer's site).
2. **CAUTION!** Fit the O-ring supplied as shown in the diagram. in order to prevent dirt and moisture from entering.
Press the connector securely into the bushing and fully tighten the union nut. Do not let the cable connector hang loose.
3. Screw the impact protection tube tightly onto the transmitter.

4. **i** Fix the impact protection tube with an open-ended wrench. Only then screw the customer's pipe onto the installation.

6.2.7 Mounting the sensor cable at the sensor

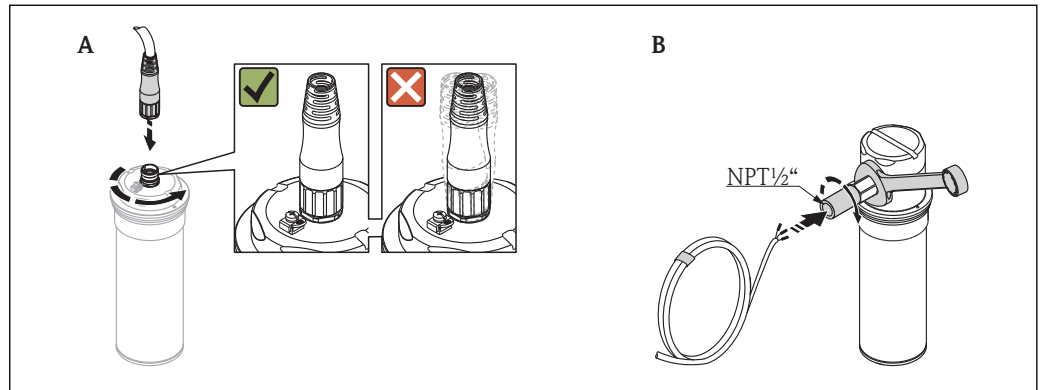

A Sensor without connection compartment

B Sensor with connection compartment

- i** **A:** Press the connector securely into the bushing and fully tighten the union nut. Do not let the cable connector hang loose.

A+B: For further information on electrical connection of the sensor, (→ [28](#))

6.2.8 Post-installation check

- Is the device undamaged (visual inspection)?
- Does the device conform to the measuring point specifications? For example:
 - Ambient temperature range
 - Measuring height
- Are the measuring point identification and labeling correct (visual inspection)?
- Is the device adequately protected from precipitation and direct sunlight?
- Are the securing screws and securing clamp tightened securely?

7 Electrical connection

7.1 Connection conditions

7.1.1 Requirements for connecting cable

Cable specifications at the transmitter

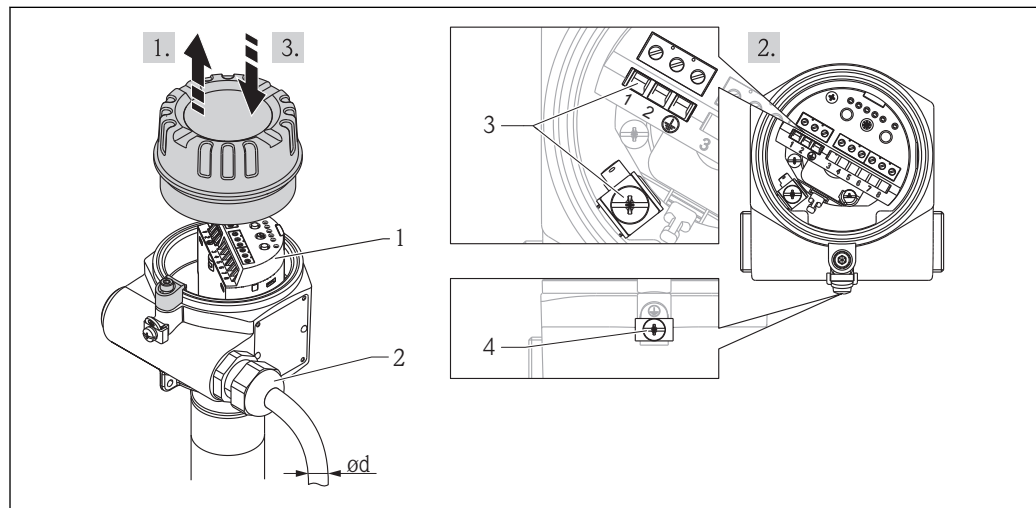

A0016351

- 1 Electronic insert
- 2 Cable entry, M20x1.5 (for further information, see table below)
- 3 Cable core, max. 2.5 mm² (AWG 14)
- 4 Cable core with max. 4 mm² (AWG 12)

1. Release cover clamp and unscrew the cover
2. Wire the transmitter
3. Screw down the cover



The thread and O-ring may not be lubricated.

Cable diameter

Cable entry material	Cable diameter d
Brass	7 to 15.5 mm (0.28 to 0.41 in)
Plastic	5 to 10 mm (0.2 to 0.38 in)
Stainless steel	7 to 12 mm (0.28 to 0.47 in)

7.1.2 Terminal assignment

Transmitter

Relay output (FEG24)

The universal current connection with relay output (DPDT) works with two different voltage ranges (19 to 253 V_{AC} or 19 to 55 V_{DC}) and is suitable for overvoltage category II.

i Use spark suppression to protect the relay contacts when connecting high-inductivity devices.

Signal on alarm:

Output signal on power failure or in the event of device failure: relay de-energized.

Connectable power

- Loads switched via 2 potential-free changeover contacts (DPDT)
- I~ max. 4 A; U~ max. 253 V; P~ max. 1 000 VA where $\cos \varphi = 1$; P~ max. 750 VA where $\cos \varphi = 0.7$
- I- max. 4 A to 30 V; I- max. 0.2 A to 125 V
- Switching delay: 0.4 s, 1.5 s, 5 s, 10 s

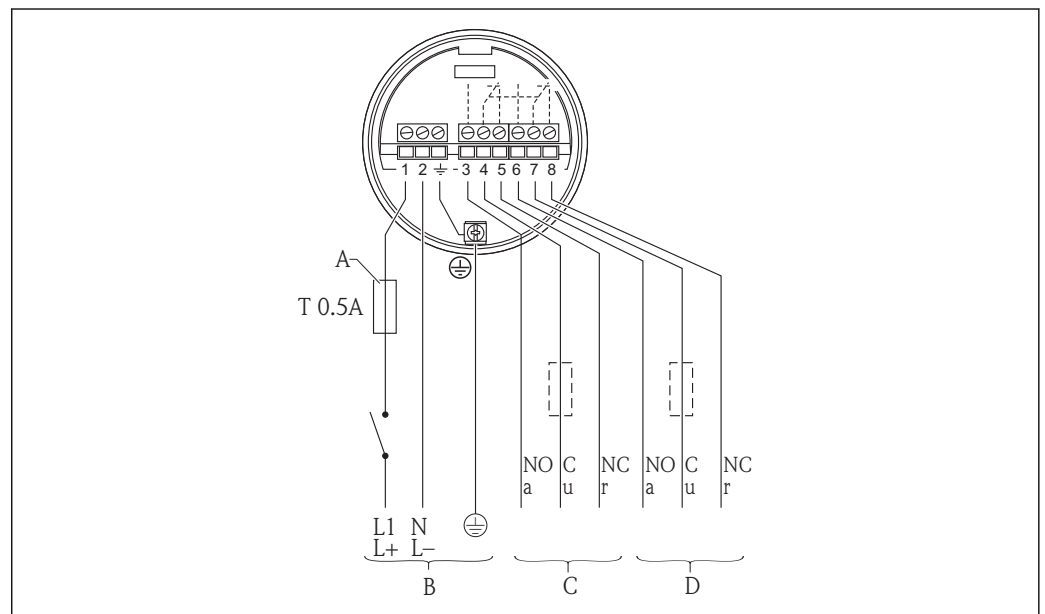

- A Fuse as per IEC 60127, T 0.5 A
- B Supply voltage: 19 to 253 V_{AC} or 19 to 55 V_{DC}
- C Relay: contact circuit 1
- D Relay: contact circuit 2

⚠ WARNING

Contact circuit 1 (terminals 3, 4, 5) is separated from contact circuit 2 (terminals 6, 7, 8) by basic insulation only.

- ▶ Do not connect any circuits which must be separated by double or reinforced insulation to contact circuit 1 and 2. For example, a SELV circuit must **not** be combined with a mains supply circuit.

*Current output (FEG25)**Current output operating modes*

Operating mode	Comments
Switching mode 8/16 mA (min. or max. point level detection)	<ul style="list-style-type: none"> ■ The switching time can be selected: 0.4 s, 1.5 s, 5 s, 10 s (depending on the calibration values) ■ Output current: 8/16 mA switching ■ Error current: ≥ 21 mA
Analog mode 4 to 20 mA	<ul style="list-style-type: none"> ■ The output current continuously changes from 4 mA (radiation path completely covered) to 20 mA (radiation path completely free). The conversion to a switch signal takes place in an external transmitter (e.g. RMA42) or the PLC. ■ Error current: ≥ 21 mA ■ Integration time 0.4 s, 1.5 s, 5 s, 10 s (can be selected), does not depend on calibration values

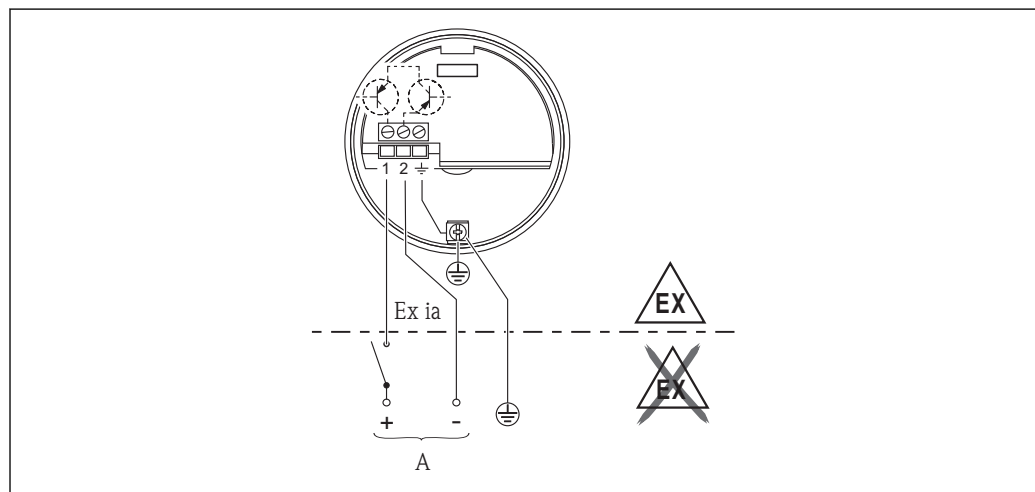

A0015973

A U- 11 to 36 VDC (30 VDC); e.g. from PLC

7.2 Connecting the measuring device

7.2.1 Connecting the transmitter

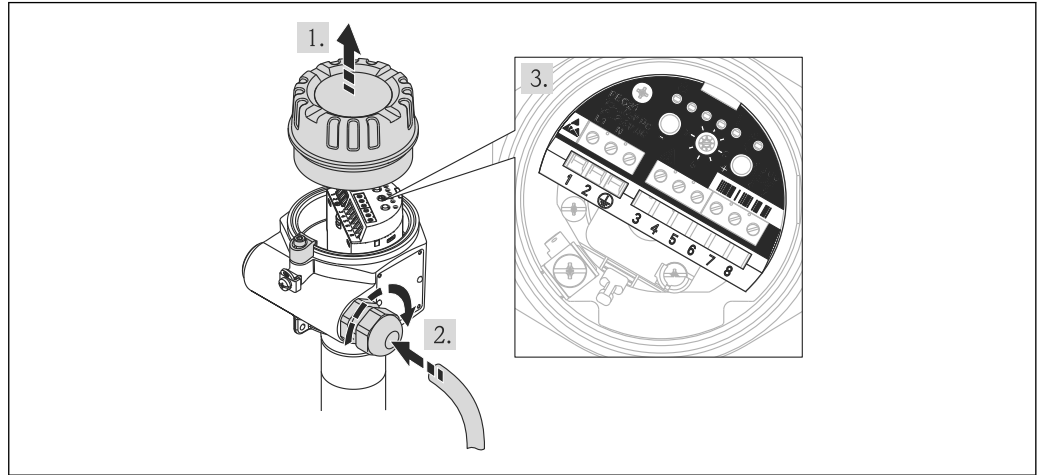









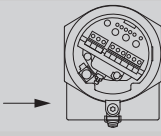
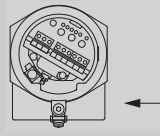







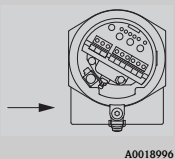
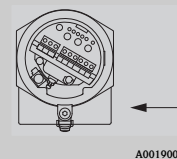

A0016431

See the information in the "Cable entries" section.

1. Release cover clamp and unscrew the cover.
2. Release the cable gland and insert the appropriate cable. Then tighten the cable gland again.
3. Connect as described on .

Cable entries

Cable entry, left		Cable entry, right	
			
	A0018996		A0019000
	Description: Sealing plug, cable gland M20x1.5 (non-hazardous area) ¹⁾ Comment: Only remove the plug if a cable connection is required at both ends. Housing: F13		Description: Cable gland M20x1.5 ¹⁾ Comment: Release the top part of the cable gland to connect the device. Housing: F13
	Description: Sealing plug, cable gland M20x1.5 (hazardous area) ¹⁾ Housing: F13 Comment: Only remove the plug if a cable connection is required at both ends.		Description: Cable gland M20x1.5 ¹⁾ Housing: F13 Comment: Release the top part of the cable gland to connect the device.
	Description: Sealing plug, thread M20x1.5 ¹⁾ Housing: F13 Comment: Only remove the plug if a cable connection is required at both ends.		Description: Sealing plug M20x1.5 ¹⁾ Housing: F13 Comment: Remove the plug to connect the device.
	Description: Sealing plug G1/2 ¹⁾ Housing: F13 Comment: Only remove the plug if a cable connection is required at both ends.		Description: Sealing plug G1/2 ¹⁾ Housing: F13 Comment: Remove the plug to connect the device.
	A0018991		A0018990

Cable entry, left		Cable entry, right	
			
A0018996	A0019000		
	Description: Cable gland M20x1.5 (non-hazardous area or hazardous area) 2)		Description: Sealing plug M20x1.5 1)
A0018987	Housing: F27	A0018986	Housing: F27
	Comment: Only remove the plug if a cable connection is required at both ends.		Comment: Release the top part of the cable gland to connect the device.
	Description: Sealing plug M20x1.5 1)		Description: Sealing plug M20x1.5 1)
A0018987	Housing: F27	A0018992	Housing: F27
	Comment: Only remove the plug if a cable connection is required at both ends.		Comment: Remove the plug to connect the device.
	Description: Adapter M20x1.5 - G1/2 1)		Description: Adapter M20x1.5 - G1/2 1)
A0018989	Housing: F27	A0018995	Housing: F27
	Comment: Threaded adapter may not be removed.		Comment: Threaded adapter may not be removed.
	Description: Sealing plug G1/2 1)		Description: Sealing plug G1/2 1)
A0018991	Housing: F27	A0018990	Housing: F27
	Comment: Only remove the plug if a cable connection is required at both ends.		Comment: Remove the plug to connect the device.
	Description: Sealing plug NPT3/4		Description: Sealing plug NPT3/4
A0018993	Housing: F13 and F27	A0018993	Housing: F13 and F27
	Comment: Only remove the plug if a cable connection is required at both ends.		Comment: Remove the plug to connect the device.

- 1) An O-ring is also used. Material: EPDM
- 2) An O-ring is also used. Material: NBR

7.2.2 Connecting the sensor

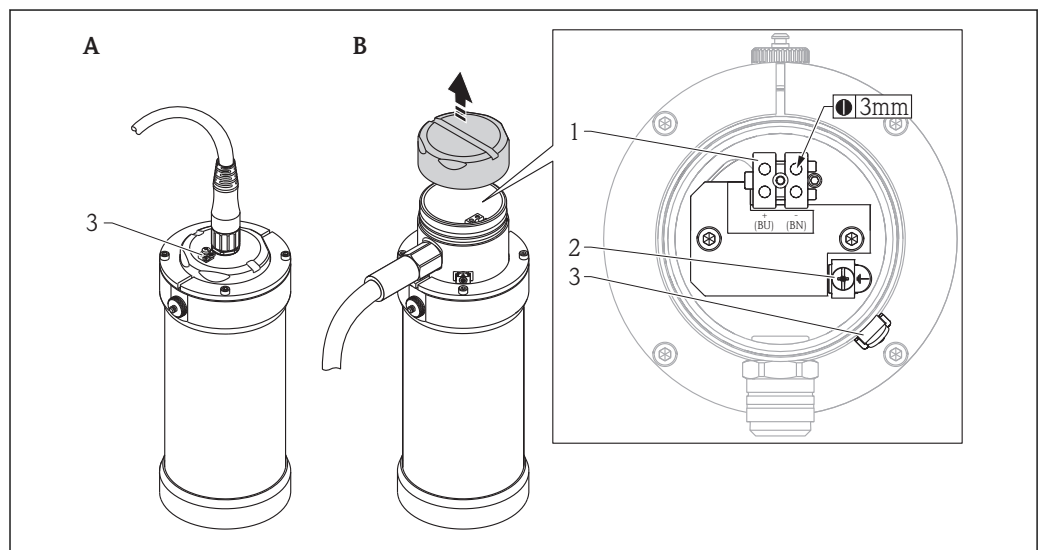





- 1 Terminals
- 2 Ground terminal, internal
- 3 Ground terminal, external

A0017207

- Version A
The sensor is already connected by attaching the cable
 - Version B
Establish the connection (observe color coding), screw the cover back on and set the function switch on the electronic insert to position 1 (operation), switch on the supply voltage...
-  The thread and O-ring may not be lubricated.

7.3 Post-connection check

Post-connection check prior to commissioning:

- Are the device and cable undamaged (visual check)?
- Do the cables comply with the requirements ?
- Do the cables have adequate strain relief?
- Are all the cable glands and dummy plugs installed, firmly tightened and leak-tight?
- Does the supply voltage match the specifications on the nameplate?
- Is the terminal assignment correct ?
 - FEG24:(→  25)
 - FEG25:(→  26)
- If required: Has protective ground connection been established ?
 - FEG24:(→  25)
 - FEG25:(→  26)
- If supply voltage is present:
 - Is the device ready for operation and are the LEDs on the electronic insert lit/flashing?

Post-connection check after commissioning:

- Is the housing cover installed and firmly tightened?
- Is the securing clamp tightened correctly?

 Switching on the supply voltage can trigger unintentional processes. Do not switch on the supply voltage until you have familiarized yourself with the device functions.

7.4 Signal on alarm

- Relay output (FEG24): Relay de-energized
- Current output (FEG25): Error current to NE43, i.e. ≤ 3.6 mA or ≥ 21 mA
- LED 5 (red) on the electronic insert lights up.

8 Operation options

8.1 Access to the operating menu via the local display

8.2 Display and operating elements

You can operate the FEG24 and FEG25 electronic inserts using function switch (6) and keys "-" (5) and "+" (4). The function switch has 8 settings, each setting having at least one function. Light emitting diodes (LEDs 1 to 6) on the electronic insert indicate the operating status which depends on the function switch setting.

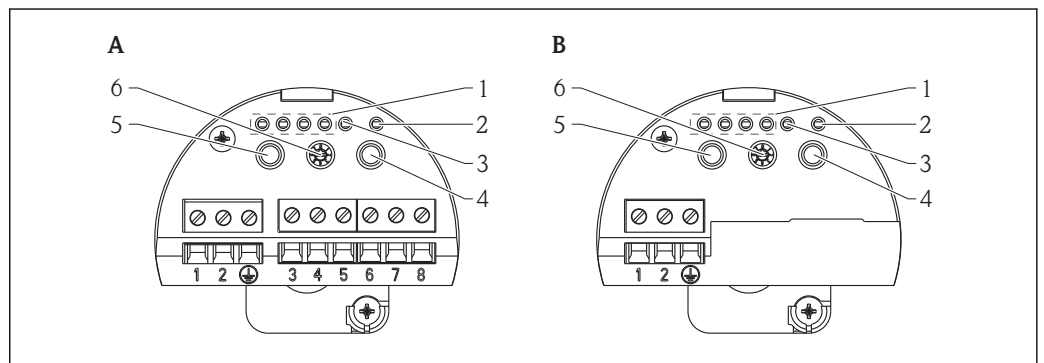

A0016114

A FEG24

B FEG25

1 Green LEDs 1 to 4; meaning depends on the function switch setting and the operating mode

2 Yellow LED; displays the current switching position

3 Red LED; indicates fault

4 "+" key; meaning depends on function switch setting

5 "-" key; meaning depends on function switch setting

6 Function switch (settings 1 to 8)

9 Commissioning

9.1 Function check

Before commissioning your measuring point, ensure that the post-installation and post-connection check have been performed.

- "Post-mounting check" checklist (→ [23](#))
- "Post-connection check" checklist (→ [30](#))

9.2 General information about commissioning

i Modified settings are saved by turning the function switch to position 1. For this reason the function switch must always be turned to position 1 after every commissioning.

There are two ways to perform commissioning:

- Commissioning with manual calibration (order configuration or after reset) (→ [32](#))
- Commissioning with automatic calibration (→ [40](#))

9.3 Commissioning with manual calibration

i In the as-delivered state and following a calibration, the Gammapilot FTG20 is in the "Manual calibration" mode. Green LED 1 is not lit. Green LEDs 2-4 and the red LED are lit. This means the "Incomplete calibration" alarm (→ [43](#)).

NOTICE

Following a manual calibration the decay compensation must be configured as otherwise the switch points are not automatically readjusted to match the decay of the radiation source.

- ▶ Configure the decay compensation (→ [37](#)).

i On delivery the Gammapilot FTG20 is in the "Manual calibration" mode. If the mode has been changed, the "Manual calibration" mode can be recovered by a "Reset".

i If commissioning is activated, at least "free" and "covered" calibration must be carried out.

9.3.1 Manual "free" and "covered" calibration

1. Turn the function switch to position 3. The green LEDs indicate the status of the calibration, see (→ [42](#)).
2. Switch on the radiation protection container.
3. Drain the container to the extent that the radiation path is free (additional draining does not result in a higher radiation/pulse rate at the detector).
4. Press the "-" key: LED 1 flashes while the free calibration process is in progress. LED 1 is lit when the free calibration process is finished.
5. Fill the container to the extent that the radiation path is covered (more easily done if the source container is switched off).
6. Press the "+" key: LED 4 flashes while the covered calibration process is in progress. LED 4 is lit when the covered calibration process is finished.
7. Turn the function switch back to position 1 (operation).

9.3.2 Maximum point level detection (standard following a reset or in when device is delivered)

Output behavior with maximum point level detection

	Output	
	8/16 mA	Relay
Radiation path "free"	16	Energized
Radiation path "covered"	8	De-energized

Setting maximum point level detection

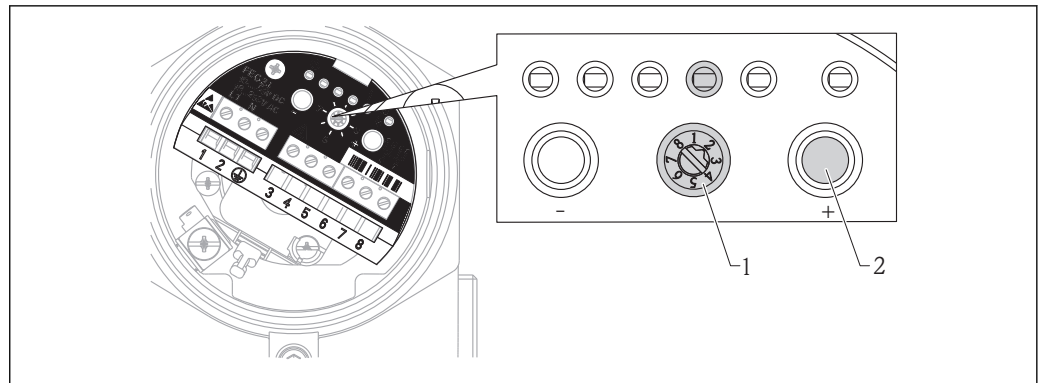

A0016130

1. Turn the function switch (1) to position 2.
2. Press the "+" button (2). Green LED 4 is lit. LEDs 1-3 are not lit.
3. Turn the function switch (1) back to position 1 (operation).

9.3.3 Minimum point level detection

Output behavior with minimum point level detection

	Output	
	8/16 mA	Relay
Radiation path "free"	8	De-energized
Radiation path "covered"	16	Energized

Setting minimum point level detection

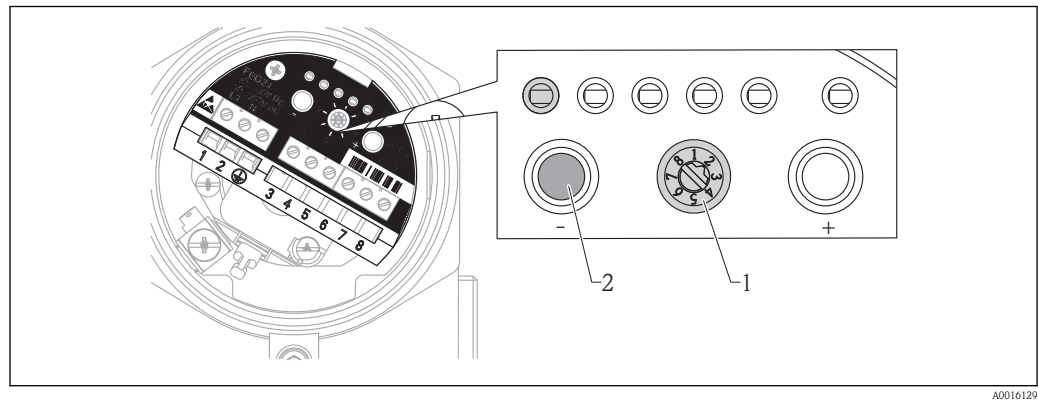

1. Turn the function switch (1) to position 2.
2. Press the "-" button (2). Green LED 1 is lit. Green LEDs 2-4 are not lit.
3. Turn the function switch (1) back to position 1 (operation).

WARNING

Decay compensation does not occur.

- Ensure the switching function works correctly by inspecting it regularly (e.g. half-yearly).

9.3.4 Setting the analog mode (only for FEG25)

In the default setting, the current output works in the switching mode (8/16 mA). Proceed as follows to set the analog mode:

1. Turn the function switch to position 2.
2. Press the "-" and "+" keys simultaneously. Green LED 2 and LED 3 flash. LED 1 and LED 4 are off.
3. Turn the function switch back to position 1 (operation).

i When the unit is switched to the analog mode the integration time is set to 0.4 s by default (→ 36).

Output behavior in the analog mode

	4 to 20 mA
Radiation path "free"	20 ¹⁾
Radiation path "covered"	4 ¹⁾

1) Not modifiable

9.3.5 Manually adjusting "free" calibration

 Normally there is no need to manually adjust free calibration. Manual adjustment aids calibration if it is not possible to perform free calibration in the process. The adjustment values are available from Endress+Hauser.

1. Turn the function switch to position 4. The green LEDs indicate the pulse rate of the free calibration, see the table below.
2. To reduce the pulse rate, press the "-" key; to increase it, press the "+" key.
3. Turn the function switch back to position 1 (operation).

 The pulse rate goes up or down one level each time the key is pressed, see the table below.

Meaning of the LEDs in switch position 4

Level	CPS (counts per second)	LED 1	LED 2	LED 3	LED 4
0	No calibration value available	•	•	•	•
1	0 to 5	◉ 1 Hz	•	•	•
2	6 to 10	◉ 5 Hz	•	•	•
3	11 to 15	☼	•	•	•
4	16 to 20	☼	◉ 1 Hz	•	•
5	21 to 25	☼	◉ 5 Hz	•	•
6	26 to 30	☼	☼	•	•
7	31 to 50	☼	☼	◉ 1 Hz	•
8	51 to 100	☼	☼	◉ 5 Hz	•
9	101 to 150	☼	☼	☼	•
10	151 to 200	☼	☼	☼	◉ 1 Hz
11	201 to 250	☼	☼	☼	◉ 5 Hz
12	251 to 300	☼	☼	☼	☼

Explanation of the LED states

•	LED off
◉ 1 Hz	LED flashes slowly (1 Hz)
◉ 5 Hz	LED flashes quickly (5 Hz)
☼	LED permanently lit

 CPS > 300 generate the alarm "Radiation too high", see (→  43).

9.3.6 Switching delay/integration time

 The switching delay is automatically set to the fastest possible value by the "free" and "covered" calibration. Where necessary a longer delay time can also be entered.

1. Turn the function switch to position 5. The green flashing LEDs indicate the switching delay that can be selected, see the table below.
2. To reduce the switching delay, press the "-" key; to increase it, press the "+" key.
3. Turn the function switch back to position 1 (operation).

Meaning of the LEDs in switch position 5

LED 1	LED 2	LED 3	LED 4
• / ● / ✨	• / ● / ✨	• / ● / ✨	• / ● / ✨
0.4 s	1.5 s	5 s	10 s

-  All the four states can be set in the analog mode.
- The integration time is set to 0.4 s by default.
 - In the automatic mode, the switching delay is set at 5 s and cannot be changed.

Explanation of the LED states

•	LED off: This switching delay cannot be set with the operating conditions present.
●	LED flashes: The switching delay can be set via the "-" and "+" key.
✨	LED is lit: The switching delay currently selected.

9.3.7 Decay compensation

As the activity of the radiation source decreases over time, the switch points need to be readjusted accordingly. The decay compensation function is used for this purpose. To ensure the device can calculate the decay compensation correctly, the isotope used must be specified.

1. Turn the function switch to position 6. The green LEDs indicate the isotope set, see the table below.
2. Select the isotope with the "-" and "+" keys.
3. Turn the function switch back to position 1 (operation).

Meaning of the LEDs in switch position 6

LED 1	LED 2	LED 3	LED 4
• / ☼	• / ☼	•	• / ☼
¹³⁷ Cs Half-life: 30 a	⁶⁰ Co Half-life 5.3 a	-	No decay compensation

Explanation of the LED states

•	LED off
☼	LED is lit: the isotope currently selected

NOTICE

In the standard setting, no decay compensation is configured. Therefore if minimum point level detection is used, after some time the system no longer reliably detects that a container is running empty.

- ▶ Always configure decay compensation if using minimum point level detection.

NOTICE

Decay compensation only takes place when the device is in operation. Times when the device is switched off are not included in the compensation.

- ▶ Do not switch off the device. Ensure the switching function works correctly by inspecting it regularly (e.g. half-yearly).
- ▶ The calibration must be repeated if the device has been switched off for an extended period.

- i
 - In the automatic mode the device automatically readjusts the limits. Compensation is not required in such cases.
 - The decay compensation uses the device operating time since the last "free" and "empty" calibration. Therefore the compensation can also be changed after years (e.g. from "no decay compensation" to "¹³⁷Cs" without the need for a recalibration).

9.3.8 Backup / restore

- i** ■ The customer-specific settings (e.g. "free" and "covered" calibration) are saved automatically once a day in the HistoROM in the housing.
- Following a parameter change, a backup of the data should be saved in the HistoROM.
 - When the electronic insert is replaced, all the data in the HistoROM can be transmitted to the electronic insert by performing a manual "restore". No other settings are required.
 - If the customer-specific settings of an electronic insert are to be transmitted to several HistoROM memory units, for instance, a manual backup must be performed after installing the electronic insert.
- **Restore**
With a restore, the saved data are transmitted from the HistoROM to the electronic insert. The electronic insert does not need any further configuration and the device is ready for operation following the restore.
- **Backup**
With a backup, the saved data are transmitted from the electronic insert to the HistoROM.
1. Turn the function switch to position 7.
 2. Press the "-" key if a restore is possible: download the restore file to the electronics. LED 1 flashes while the file is being downloaded. LED 1 is lit when the download is finished.
 3. Press the "+" key if a backup is possible: upload the backup file to the HistoROM. LED 4 flashes while the file is being uploaded. LED 4 is lit when the upload is finished.
 4. Turn the function switch back to position 1 (operation).

Meaning of the LEDs in switch position 7

LED 1	LED 2	LED 3	LED 4
• Restore not possible	•	•	• Backup not possible
☼ Restore is possible	•	•	☼ Backup is possible
● Restore in progress	•	•	● Backup in progress

Explanation of the LED states

•	LED off
●	LED flashes
☼	LED is lit

NOTICE

If the electronic insert is converted to another version, the calibration values in the HistoROM are deleted without any request for confirmation from the user.

- ▶ The electronic insert FEG25 is not designed for conversion to electronic insert FEG24 or vice versa.

9.3.9 Displaying the current pulse rate / function test

Pulse rate

1. Turn the function switch to position 8. The green LEDs indicate the current pulse rate, see the table below.
2. To display the "free calibration" pulse rate: press and hold the "-" key.
3. To display the "covered calibration" pulse rate: press and hold the "+" key.
4. Turn the function switch back to position 1 (operation).

Meaning of the LEDs in switch position 8

Level	CPS (counts per second)	LED 1	LED 2	LED 3	LED 4
0	No calibration value available	•	•	•	•
1	0 to 5	◉ 1 Hz	•	•	•
2	6 to 10	◉ 5 Hz	•	•	•
3	11 to 15	☼	•	•	•
4	16 to 20	☼	◉ 1 Hz	•	•
5	21 to 25	☼	◉ 5 Hz	•	•
6	26 to 30	☼	☼	•	•
7	31 to 50	☼	☼	◉ 1 Hz	•
8	51 to 100	☼	☼	◉ 5 Hz	•
9	101 to 150	☼	☼	☼	•
10	151 to 200	☼	☼	☼	◉ 1 Hz
11	201 to 250	☼	☼	☼	◉ 5 Hz
12	251 to 300	☼	☼	☼	☼

Explanation of the LED states

•	LED off
◉ 1 Hz	LED flashes slowly (1 Hz)
◉ 5 Hz	LED flashes more quickly (5 Hz)
☼	LED permanently lit

 CPS > 300 generate the alarm "Radiation too high" (→  43).

Function test

The function test is used to check the following:

- LEDs. LED1 to LED6 flash slowly during the function test (1Hz).
- Wiring. The switch output alternates at the same speed between the two switching states (relay: on/off or 8 mA/16 mA).

The function test takes 10 s. Normal operation is then resumed.

1. Turn the function switch to position 8.
2. To perform the function test, press and hold the "-" and "+" keys simultaneously.
3. Then turn the function switch back to position 1 (operation).

9.4 Commissioning with automatic calibration

The Gammapilot FTG20 offers users an automatic mode in which the "free" and "covered" calibration points are constantly updated automatically. In this way, changes to buildup formation or the deterioration and aging of the radiation source are compensated automatically.

The starting values for the switch point, the hysteresis and the switching delay are already defined and set in the device in the as-delivered state or following a reset. If the FTG20 is operated for at least 3 min in the free and covered state, the pulse rates recorded in a bar chart are saved as calibration values. The switch point and the hysteresis are recalculated on the basis of these calibration values. Therefore attention must be paid to the following basic conditions for the automatic mode when commissioning for the first time or following a reset:

- The pulse rate must be greater than 30 cps in the "uncovered" state (function switch in position 8 (→ [39](#))).
- The pulse rate must be less than 10 cps in the "covered" state (function switch in position 8 (→ [39](#))).
- There are at least 5 half-value layers between the covered and uncovered ("free") state (corresponds to approx. 60 cm (23.6 in) water for ¹³⁷Cs).
- The state must change (from covered to uncovered or vice versa) within 10 s (not suitable for slow processes, approx. 9 mm/s).
- To ensure the free and covered states are saved as calibration values in FTG20, reach and hold both states for at least 3 min. Only then are the switch point and hysteresis optimized and incorrect switching is avoided.

The switching delay in the automatic mode is 5 s and cannot be changed.

Depending on the sensor version, the following are thus the requirements for configuring the measuring point:

Number of Geiger-Müller counters	Local dose rate for ¹³⁷ Cs		Local dose rate for ⁶⁰ Co	
	Status "free"	Status "covered"	Status "free"	Status "covered"
1	≥ 3.0 μSv/h	≤ 1.0 μSv/h	≥ 2.5 μSv/h	≤ 0.8 μSv/h
2	≥ 1.5 μSv/h	≤ 0.5 μSv/h	≥ 1.3 μSv/h	≤ 0.4 μSv/h
3	≥ 1.0 μSv/h	≤ 0.3 μSv/h	≥ 0.9 μSv/h	≤ 0.2 μSv/h

9.4.1 Starting the automatic mode

1. Turn the function switch (1) to position 3.
2. Press the "+" and "-" keys simultaneously. Green LED 2 and LED 3 flash. LED 1 and LED 4 are off.
3. Turn the function switch (1) back to position 1.

 The automatic mode always starts with the "Maximum point level" switching function. Where necessary, the setting must be changed once the automatic mode has started.

9.4.2 Maximum point level detection

See (→ [33](#)).

9.4.3 Minimum point level detection

See (→ [34](#)).

9.5 Performing a total reset

i If a total reset is performed, all the settings that have been made up until now are lost. The device then works in the "Manual calibration" operating mode. The HistoROM is cleared. It is no longer possible to restore the settings to the previous state.

1. Turn the function switch (1) to position 1.
2. Press the "-" and "+" keys simultaneously for 8 s. Green LED 1 to LED 4 light up one after another for 2 s each.

9.6 Record of commissioning

Date:

Free calibration pulse rate:

c/s

Covered calibration pulse rate:

c/s

Integration time:

s

Decay compensation:

Cs137

Co60

None

Serial number

Transmitter:

Sensor:

10 Diagnostics and troubleshooting

10.1 Meaning of LEDs 1-4 in switch position 3

LED 1	Meaning	LED 2/3	Meaning	LED 4	Meaning
•	"Free" calibration data missing	● ●	Automatic mode Device behaves as described in (→ 40).	•	"Covered" calibration data missing
●	"Free" calibration in progress	• •	Not in automatic mode. Manual calibration required, in accordance with display of LED 1 and LED 4.	●	"Covered" calibration in progress
☼	"Free" calibration data available			☼	"Covered" calibration data available

Explanation of the LED states

•	LED off
●	LED flashes
☼	LED is lit

- i** The pulse rate must be higher for free calibration than for covered calibration, as otherwise the error message "Incomplete calibration or free calibration \leq covered calibration" is displayed in the measuring range (function switch in position 1).
- If the calibration data are already available, the calibration can be performed again without a reset.

10.2 Error messages

- i** If an error occurs when the device is being commissioned or operated, the error message is displayed using LEDs 1 to 5. If several errors are detected by the diagnostics function, these errors are displayed by order of priority. A critical error is always displayed before a less serious error.
 - The error messages are only displayed in position 1 of the function switch.
 - Display last error: hold "-"
 - Display penultimate error: hold "+"

10.2.1 Operation; LED5 off

LED 1	LED 2	LED 3	LED 4	LED 5	Cause	Remedy
☼	•	•	•	•	No error	-

10.2.2 Alarm; LED 5 is lit red

An error signal is output:

- Relay: de-energized
- 8/16 mA: ≥ 21 mA
- 4 to 20 mA: ≥ 21 mA

LED 1	LED 2	LED 3	LED 4	LED 5	Cause	Remedy
•	•	•	☼	☼	<ul style="list-style-type: none"> ■ Device out of service ■ ROM defective 	Change the main electronics
•	•	☼	•	☼	<ul style="list-style-type: none"> ■ Device out of service ■ RAM defective 	Change the main electronics
•	•	☼	☼	☼	Defective supply voltage	<ul style="list-style-type: none"> ■ Suggest the last error: Is it "Radiation too high", note the cause "Radiation too high" ■ Check sensor supply cable for short-circuiting ■ Change the main electronics / sensor
•	☼	•	•	☼	No sensor connected	Connect or replace the sensor
•	☼	☼	•	☼	Radiation too high	<ul style="list-style-type: none"> ■ Eliminate extraneous radiation ■ Attenuate radiation ■ Replace radiation source
•	☼	☼	☼	☼	Incomplete calibration, or free calibration \leq covered calibration	Perform or configure "free" and "covered" calibration.
☼	•	•	•	☼	Initial process (no errors)	Wait for approx. 20 s
☼	•	•	☼	☼	Auto mode is not possible as source is too strong or too weak, for instance	<ul style="list-style-type: none"> ■ Replace radiation source, attenuate radiation source if necessary ■ Change number of Geiger-Müller counters ■ Perform manual calibration

10.2.3 Warning; LED 5 flashes

LED 1	LED 2	LED 3	LED 4	LED 5	Cause	Remedy
☼	☼	•	•	⦿	Overranging	Perform calibration again
☼	☼	•	☼	⦿	Unpermitted temperature	Operate device in spec. temperature range
☼	☼	☼	•	⦿	Set switching delay too short or radiation too weak	<ul style="list-style-type: none"> ■ Check alignment of radiation protection container ■ Increase switching delay ■ Change number of Geiger-Müller counters ■ Replace radiation source
☼	☼	☼	☼	⦿	<ul style="list-style-type: none"> ■ Inconsistent data ■ No HistoROM ■ HistoROM defective ■ Data corrupt 	<ul style="list-style-type: none"> ■ Backup or restore data ■ Check HistoROM ■ Replace HistoROM ■ Perform reset + calibration

10.2.4 Special case; LED1-4 off

LED 1	LED 2	LED 3	LED 4	LED 5	Cause	Remedy
•	•	•	•	•	Device out of service ¹⁾	Connect device to power supply
•	•	•	•	•	Electronics unit is defective. ¹⁾	<ul style="list-style-type: none"> ■ Check sensor supply cable for short-circuiting ■ Change the main electronics
•	•	•	•	☼	Electronics unit is defective. ¹⁾	Replace electronics

1) Note! Error current can be <3.6 mA in this case.

11 Repair

11.1 General notes

11.1.1 Repair concept

The Endress+Hauser repair concept requires devices to have a modular design and requires repairs to be carried out by Endress+Hauser Service or by properly trained staff.

Spare parts are grouped into logical kits with the associated replacement instructions. For more information on service and spare parts contact Endress+Hauser Service.

11.1.2 Repair of Ex-certified devices

When repairing Ex-certified devices, please also note the following:

- Only specialist personnel or Endress+Hauser-Service can carry out repairs to Ex certified devices.
- Relevant standards and national regulations as well as safety instructions (XA) and certificates must be observed.
- Only genuine Endress+Hauser spare parts may be used.
- When ordering spare parts, please check the device designation on the nameplate. Identical parts may only be used as replacements.
- Carry out repairs according to the instructions. Following a repair, the device must fulfill the requirements of the individual tests specified for that device.
- A certified device may be converted to another certified device version by Endress+Hauser Service only.
- All repairs and modifications must be documented.

11.1.3 Replacing electronics modules

When electronics modules have been replaced the device does not need to be recalibrated as the parameters are saved in the HistoROM inside the housing. A "Restore" should be performed. The electronic insert is not designed for conversion to another electronic insert (e.g. conversion from FEG25 to FEG24).

11.2 Spare parts

You can find spare parts for your measuring device on our website *www.endress.com*. Proceed as follows here:

1. Select "www.endress.com" and then select the country.
2. Click the "Instruments" button.
3. Enter the product name in the "Product name" field.
4. Select the measuring device.
5. Select the "Accessories/Spare parts" tab.
6. Select spare parts (see also the overview drawing on the right of the screen)

When ordering a spare part, always specify the serial number that is indicated on the nameplate.

11.3 Endress+Hauser services

 Contact your Endress+Hauser Sales Center for information on services and spare parts.

12 Maintenance

12.1 Maintenance tasks

- No special maintenance work is required.
- If minimum point level detection is used, ensure the switching function works correctly by inspecting it regularly (e.g. annually).

12.1.1 Exterior cleaning

When cleaning the exterior, always use cleaning agents that do not corrode the surface of the housing and the seals (see TI01023F/00/EN).

12.2 Endress+Hauser services

Endress+Hauser offers a wide variety of services for maintenance such as recalibration, maintenance service or device tests.



Your Endress+Hauser Sales Center can provide detailed information on the services.

13 Return

The measuring device must be returned if repairs or a factory calibration are required, or if the wrong measuring device has been ordered or delivered. According to legal regulations, Endress+Hauser, as an ISO-certified company, is required to follow certain procedures when handling returned products that are in contact with medium.

To ensure swift, safe and professional device returns, please read the return procedures and conditions on the Endress+Hauser website at www.services.endress.com/return-material

14 Appendix

14.1 Overview of the operating menu

Position 1, operation / status display (→ 39)					
Meaning	Action	LEDs (green)			
		1	2	3	4
Operation		☼	•	•	•
Alarm is pending		Error message displayed (→ 42)			
Warning is pending					
Display last error	Hold "-"				
Display penultimate error	Hold "+"				
Total reset; each LED is lit for 2 s in succession	Hold "+" and "-" for 8 seconds	☼	☼	☼	☼
Out of service		•	•	•	•

Position 2, measuring mode (→ 33)					
Meaning	Action	LEDs (green)			
		1	2	3	4
Configure "Max. safety" measuring mode	Press "+"				
"Max. safety" measuring mode is configured		•	•	•	☼
Configure "Min. safety" measuring mode	Press "-"				
"Min. safety" measuring mode is configured		☼	•	•	•
Configure "Analog mode" measuring mode	Press "+" and "-" simultaneously				
"Analog mode" measuring mode is configured		•	●	●	•

Position 3, manual calibration (→ 32)					
Meaning	Action	LEDs (green)			
		1	2	3	4
Man. "free" calibration data missing	Press "-" to start "free" calibration	•	•	•	•
Man. "free" calibration in progress		●	•	•	• / ☼
Man. "free" calibration data available		☼	•	•	• / ☼
Man. "covered" calibration data missing	Press "+" to start "covered" calibration	•	•	•	•
Man. "covered" calibration in progress		• / ☼	•	•	●
Man. "covered" calibration data available		• / ☼	•	•	☼
Automatic mode; no manual calibration	Press "+" and "-" simultaneously	•	●	●	•

Position 4, free calibration pulse rate (→ 35)					
Meaning	Action	LEDs (green)			
		1	2	3	4
Increase pulse rate	Press "+"	Pulse rate is displayed (→ 35)			
Reduce pulse rate	Press "-"				

Position 5, switching delay (for switching mode); integration time (for analog mode) (→ 36)					
Meaning	Action	LEDs (green)			
		1	2	3	4
Increase time constant	Press "+"	Time constant is displayed (→ 36)			
Reduce time constant	Press "-"				

Position 6, decay compensation (→ 37)					
Meaning	Action	LEDs (green)			
		1	2	3	4
No compensation		•	•	•	☼
Compensation for ¹³⁷ Cs		☼	•	•	•
Compensation for ⁶⁰ Co		•	☼	•	•
Switch type of compensation	Press "+" or "-"				

Position 7, backup / restore (→ 38)					
Meaning	Action	LEDs (green)			
		1	2	3	4
Backup/restore not possible	Press "-" for restore; copy file from HistoROM to electronic insert	•	•	•	•
Backup/restore possible	Press "+" for backup; copy file from electronic insert to HistoROM	☼	•	•	☼
Backup/restore in progress		⦿	•	•	⦿

Position 8, display pulse rate/function test (→ 39)					
Meaning	Action	LEDs (green)			
		1	2	3	4
	Hold "-" to display "free calibration" pulse rate Hold "+" to display "covered calibration" pulse rate	Pulse rate is displayed (→ 35)			
Function test	Press "+" and "-" simultaneously				
Function test is active, LEDs flash for 10 s		⦿	⦿	⦿	⦿

Explanation of the LED states

•	LED off
⦿	LED flashes
☼	LED is lit

Index

Symbols

- "Free" / "covered" calibration 32
- "Free" calibration, manual 35

A

- Ambient temperature range 17
- Analog mode 26, 34

B

- Backup 38

C

- Cable entries 27
- Cable specifications 24
- CE mark (declaration of conformity) 9
- Commissioning 32
- Commissioning with manual calibration 32
- Connecting cable 24
- Connecting the measuring device 27
- Current output (FEG25) 26

D

- Decay compensation 37
- Declaration of Conformity 9
- Design
 - Measuring device 10
- Designated use
 - 8
- Device components 10
- Diagnostics 42
- Document function 4

E

- Electrical connection 24
- Endress+Hauser services 46, 47
- Exterior cleaning 47

F

- Function test 39

I

- Identifying the measuring device 13
- Incoming acceptance 12
- Information on the document 4
- Inspection check 12
- Installation 17
- Integration time 36

M

- Maintenance tasks 47
- Maximum point level detection 33
- Minimum point level detection 34
- Mounting position 17
- Mounting the measuring device 18, 18
- Mounting tools 18

N

- Nameplate 13, 14

O

- Operating menu 49
- Operation options 31
- Operational safety 8

P

- Packaging disposal 16
- Pipe mounting 18
- Post-connection check 30
- Post-installation check 23
- Product safety 9
- Pulse rate 39

R

- Record of commissioning 41
- Relay output (FEG24) 25
- Repair 45
- Requirements for personnel 8
- Restore 38
- Returning devices 48

S

- Safety 8
- Sensor 14
- Spare parts 46
- Storage conditions 16
- Supplementary documentation 7
- Switching delay 36
- Switching mode 26
- Symbols used 4

T

- Terminal assignment 25
- Total reset 41
- Transmitter 13
- Transporting the measuring device 16
- Troubleshooting 42

V

- Vibrations 18

W

- W@M Device Viewer 13, 46
- Wall mounting 18
- Workplace safety 8

www.endress.com/worldwide

Endress+Hauser 

People for Process Automation

BA01035F/00/EN/02.12
71204359
CCS/EH-COSIMA ProMoDo

