



Level



Pressure



Flow



Temperature



Liquid
Analysis



Registration



Systems
Components



Services



Solutions

Operating Instructions

Proline Promag P 200

HART

Electromagnetic flow measuring system

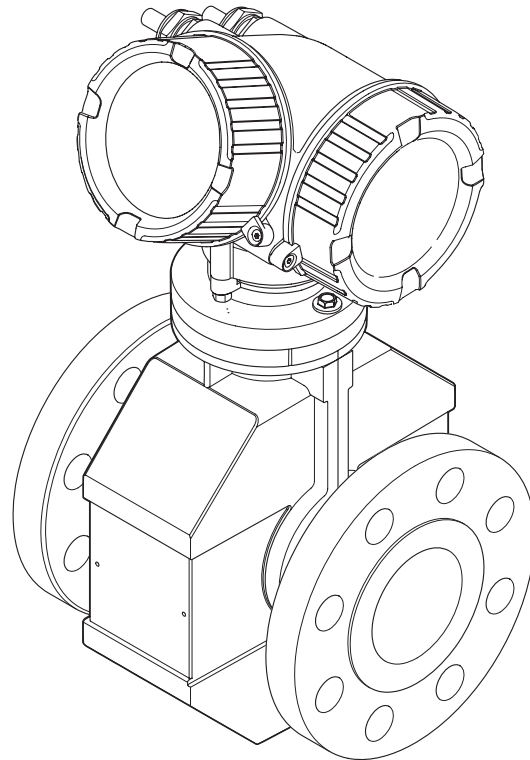

- Make sure the document is stored in a safe place such that it is always available when working on or with the device.
- To avoid danger to individuals or the facility, read the "Basic safety instructions" section carefully, as well as all other safety instructions in the document that are specific to working procedures.
- The manufacturer reserves the right to modify technical data without prior notice. Your Endress +Hauser Sales Center will supply you with current information and updates to these Instructions.

Table of contents

| | | | | | |
|----------|---|-----------|-----------|---|-----------|
| 1 | Document information | 5 | 7 | Electrical connection | 26 |
| 1.1 | Document function | 5 | 7.1 | Connection conditions | 26 |
| 1.2 | Symbols used | 5 | 7.1.1 | Required tools | 26 |
| 1.2.1 | Safety symbols | 5 | 7.1.2 | Requirements for connecting cable | 26 |
| 1.2.2 | Electrical symbols | 5 | 7.1.3 | Terminal assignment | 27 |
| 1.2.3 | Tool symbols | 5 | 7.1.4 | Requirements for the supply unit | 27 |
| 1.2.4 | Symbols for certain types of information | 6 | 7.1.5 | Preparing the measuring device | 28 |
| 1.2.5 | Symbols in graphics | 6 | 7.2 | Connecting the measuring device | 28 |
| 1.3 | Documentation | 6 | 7.2.1 | Connecting the transmitter | 29 |
| 1.3.1 | Standard documentation | 7 | 7.2.2 | Ensuring potential equalization | 30 |
| 1.3.2 | Supplementary device-dependent documentation | 7 | 7.3 | Ensuring the degree of protection | 32 |
| | | | 7.4 | Post-connection check | 32 |
| 2 | Basic safety instructions | 8 | 8 | Operation options | 33 |
| 2.1 | Requirements for the personnel | 8 | 8.1 | Overview of operation options | 33 |
| 2.2 | Designated use | 8 | 8.2 | Structure and function of the operating menu | 34 |
| 2.3 | Workplace safety | 9 | 8.2.1 | Structure of the operating menu | 34 |
| 2.4 | Operational safety | 9 | 8.2.2 | Operating philosophy | 35 |
| 2.5 | Product safety | 9 | 8.3 | Access to the operating menu via the local display | 36 |
| 3 | Product description | 10 | 8.3.1 | Operational display | 36 |
| 3.1 | Product design | 10 | 8.3.2 | Navigation view | 37 |
| 3.2 | Registered trademarks | 10 | 8.3.3 | Editing view | 39 |
| 4 | Incoming acceptance and product identification | 11 | 8.3.4 | Operating elements | 41 |
| 4.1 | Incoming acceptance | 11 | 8.3.5 | Opening the context menu | 41 |
| 4.2 | Product identification | 12 | 8.3.6 | Navigating and selecting from list | 43 |
| 4.2.1 | Transmitter nameplate | 12 | 8.3.7 | Calling the parameter directly | 43 |
| 4.2.2 | Sensor nameplate | 13 | 8.3.8 | Calling up help text | 44 |
| 4.2.3 | Symbols on measuring device | 14 | 8.3.9 | Changing the parameters | 45 |
| 5 | Storage and transport | 15 | 8.3.10 | User roles and related access authorization | 46 |
| 5.1 | Storage conditions | 15 | 8.3.11 | Disabling write protection via access code | 46 |
| 5.2 | Transporting the product | 15 | 8.3.12 | Enabling and disabling the keypad lock | 46 |
| 5.3 | Packaging disposal | 16 | 8.4 | Access to the operating menu via the operating tool | 48 |
| 6 | Installation | 17 | 8.4.1 | Connecting the operating tool | 48 |
| 6.1 | Installation conditions | 17 | 8.4.2 | Field Xpert SFX100 | 49 |
| 6.1.1 | Mounting position | 17 | 8.4.3 | FieldCare | 49 |
| 6.1.2 | Requirements from environment and process | 19 | 8.4.4 | AMS Device Manager | 50 |
| 6.1.3 | Special mounting instructions | 21 | 8.4.5 | SIMATIC PDM | 50 |
| 6.2 | Mounting the measuring device | 21 | 8.4.6 | Field Communicator 475 | 50 |
| 6.2.1 | Required tools | 21 | 9 | System integration | 51 |
| 6.2.2 | Preparing the measuring device | 21 | 9.1 | Overview of device description files | 51 |
| 6.2.3 | Mounting the sensor | 22 | 9.1.1 | Current version data for the device | 51 |
| 6.2.4 | Turning the transmitter housing | 24 | 9.1.2 | Operating tools | 51 |
| 6.2.5 | Turning the display module | 25 | 9.2 | Measured variables via HART protocol | 51 |
| 6.3 | Post-installation check | 25 | 9.3 | Other settings | 52 |
| | | | 10 | Commissioning | 53 |
| | | | 10.1 | Function check | 53 |

| | | | | | |
|-----------|--|-----------|------------------------|---|------------|
| 10.2 | Switching on the measuring device | 53 | 12.11 | Disposal | 100 |
| 10.3 | Setting the operating language | 53 | 12.11.1 | Removing the measuring device | 100 |
| 10.4 | Configuring the measuring device | 54 | 12.11.2 | Disposing of the measuring device | 101 |
| 10.4.1 | Configuring the current output | 55 | 13 | Repair | 102 |
| 10.4.2 | Configuring the pulse/frequency/switch output | 56 | 13.1 | General notes | 102 |
| 10.4.3 | Configuring the local display | 63 | 13.2 | Spare parts | 102 |
| 10.4.4 | Configuring the output conditioning | 65 | 13.3 | Endress+Hauser services | 103 |
| 10.4.5 | Configuring the low flow cut off | 66 | 14 | Maintenance | 104 |
| 10.4.6 | Configuring empty pipe detection | 68 | 14.1 | Maintenance tasks | 104 |
| 10.5 | Advanced settings | 69 | 14.1.1 | Exterior cleaning | 104 |
| 10.5.1 | Defining the tag name | 70 | 14.1.2 | Interior cleaning | 104 |
| 10.5.2 | Setting the system units | 70 | 14.2 | Measuring and test equipment | 104 |
| 10.5.3 | Carrying out a sensor adjustment | 71 | 14.3 | Endress+Hauser services | 104 |
| 10.5.4 | Configuring the totalizer | 72 | 15 | Return | 105 |
| 10.5.5 | Carrying out additional display configurations | 73 | 16 | Technical data | 106 |
| 10.6 | Configuration management | 74 | 16.1 | Application | 106 |
| 10.7 | Simulation | 76 | 16.2 | Function and system design | 106 |
| 10.8 | Protecting settings from unauthorized access | 77 | 16.3 | Input | 106 |
| 10.8.1 | Write protection via access code | 77 | 16.4 | Output | 107 |
| 10.8.2 | Write protection via write protection switch | 78 | 16.5 | Power supply | 110 |
| 11 | Operation | 81 | 16.6 | Performance characteristics | 111 |
| 11.1 | Read device locking status | 81 | 16.7 | Installation | 112 |
| 11.2 | Adjusting the operating language | 81 | 16.8 | Environment | 112 |
| 11.3 | Configuring the display | 81 | 16.9 | Process | 113 |
| 11.4 | Reading off measured values | 81 | 16.10 | Mechanical construction | 117 |
| 11.4.1 | Process variables | 81 | 16.11 | Operability | 120 |
| 11.4.2 | Totalizer | 82 | 16.12 | Certificates and approvals | 120 |
| 11.4.3 | Output values | 82 | 16.13 | Application packages | 121 |
| 11.5 | Adapting the measuring device to the process conditions | 83 | 16.14 | Accessories | 121 |
| 11.6 | Performing a totalizer reset | 83 | 16.15 | Documentation | 121 |
| 11.7 | Showing data logging | 85 | 17 | Appendix | 123 |
| 12 | Diagnostics and troubleshooting | 87 | 17.1 | Overview of the operating menu | 123 |
| 12.1 | General troubleshooting | 87 | Index | 139 | |
| 12.2 | Diagnostic information on local display | 89 | | | |
| 12.2.1 | Diagnostic message | 89 | | | |
| 12.2.2 | Calling up remedy information | 91 | | | |
| 12.3 | Diagnostic information in FieldCare | 92 | | | |
| 12.3.1 | Diagnostic options | 92 | | | |
| 12.3.2 | Calling up remedy information | 92 | | | |
| 12.4 | Adapting the diagnostic information | 92 | | | |
| 12.4.1 | Adapting the diagnostic behavior | 92 | | | |
| 12.5 | Overview of diagnostic information | 93 | | | |
| 12.6 | Pending diagnostic events | 95 | | | |
| 12.7 | Diagnostic list | 96 | | | |
| 12.8 | Event logbook | 96 | | | |
| 12.8.1 | Event history | 96 | | | |
| 12.8.2 | Filtering the event logbook | 97 | | | |
| 12.8.3 | Overview of information events | 97 | | | |
| 12.9 | Resetting the measuring device | 98 | | | |
| 12.10 | Device information | 99 | | | |





1 Document information

1.1 Document function







These Operating Instructions contain all the information that is required in various phases of the life cycle of the device: from product identification, incoming acceptance and storage, to mounting, connection, operation and commissioning through to troubleshooting, maintenance and disposal.

1.2 Symbols used

1.2.1 Safety symbols

| Symbol | Meaning |
|--|--|
|  A0011189-EN | DANGER! This symbol alerts you to a dangerous situation. Failure to avoid this situation will result in serious or fatal injury. |
|  A0011190-EN | WARNING! This symbol alerts you to a dangerous situation. Failure to avoid this situation can result in serious or fatal injury. |
|  A0011191-EN | CAUTION! This symbol alerts you to a dangerous situation. Failure to avoid this situation can result in minor or medium injury. |
|  A0011192-EN | NOTICE! This symbol contains information on procedures and other facts which do not result in personal injury. |

1.2.2 Electrical symbols





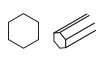





| Symbol | Meaning |
|---|--|
|  A0011197 | Direct current A terminal to which DC voltage is applied or through which direct current flows. |
|  A0011198 | Alternating current A terminal to which alternating voltage is applied or through which alternating current flows. |
|  A0017381 | Direct current and alternating current <ul style="list-style-type: none"> ■ A terminal to which alternating voltage or DC voltage is applied. ■ A terminal through which alternating current or direct current flows. |
|  A0011200 | Ground connection A grounded terminal which, as far as the operator is concerned, is grounded via a grounding system. |
|  A0011199 | Protective ground connection A terminal which must be connected to ground prior to establishing any other connections. |
|  A0011201 | Equipotential connection A connection that has to be connected to the plant grounding system: This may be a potential equalization line or a star grounding system depending on national or company codes of practice. |

1.2.3 Tool symbols







| Symbol | Meaning |
|---|------------------------|
|  A0011220 | Flat blade screwdriver |
|  A0011221 | Allen key |

| | |
|--|-------------------|
|  <small>A0011222</small> | Open-ended wrench |
|--|-------------------|

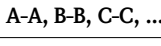

1.2.4 Symbols for certain types of information

| Symbol | Meaning |
|--|--|
|  <small>A0011182</small> | Allowed Indicates procedures, processes or actions that are allowed. |
|  <small>A0011183</small> | Preferred Indicates procedures, processes or actions that are preferred. |
|  <small>A0011184</small> | Forbidden Indicates procedures, processes or actions that are forbidden. |
|  <small>A0011193</small> | Tip Indicates additional information. |
|  <small>A0011194</small> | Reference to documentation Refers to the corresponding device documentation. |
|  <small>A0011195</small> | Reference to page Refers to the corresponding page number. |
|  <small>A0011196</small> | Reference to graphic Refers to the corresponding graphic number and page number. |
|  | Series of steps |
|  | Result of a sequence of actions |
|  <small>A0013562</small> | Help in the event of a problem |

1.2.5 Symbols in graphics

| Symbol | Meaning |
|--|--|
|  | Item numbers |
|  | Series of steps |
|  | Views |
|  | Sections |
|  <small>A0013441</small> | Flow direction |
|  <small>A0011187</small> | Hazardous area Indicates a hazardous area. |
|  <small>A0011188</small> | Safe area (non-hazardous area) Indicates a non-hazardous area. |

1.3 Documentation

-  The following document types are available:
- On the CD-ROM supplied with the device
 - In the Download Area of the Endress+Hauser Internet site: www.endress.com → Download
-  For a detailed list of the individual documents along with the documentation code (→  121)

1.3.1 Standard documentation

| Document type | Purpose and content of the document |
|------------------------------|--|
| Technical Information | Planning aid for your device The document contains all the technical data on the device and provides an overview of the accessories and other products that can be ordered for the device. |
| Brief Operating Instructions | Guide that takes you quickly to the 1st measured value The Brief Operating Instructions contain all the essential information from incoming acceptance to initial commissioning. |

1.3.2 Supplementary device-dependent documentation

Additional documents are supplied depending on the device version ordered: Always comply strictly with the instructions in the supplementary documentation. The supplementary documentation is an integral part of the device documentation.

2 Basic safety instructions

2.1 Requirements for the personnel

The personnel for installation, commissioning, diagnostics and maintenance must fulfill the following requirements:

- ▶ Trained, qualified specialists must have a relevant qualification for this specific function and task
- ▶ Are authorized by the plant owner/operator
- ▶ Are familiar with federal/national regulations
- ▶ Before beginning work, the specialist staff must have read and understood the instructions in the Operating Instructions and supplementary documentation as well as in the certificates (depending on the application)
- ▶ Following instructions and basic conditions

The operating personnel must fulfill the following requirements:

- ▶ Being instructed and authorized according to the requirements of the task by the facility's owner-operator
- ▶ Following the instructions in these Operating Instructions

2.2 Designated use

Application and media

The measuring device described in these Instructions is intended only for flow measurement of liquids with a minimum conductivity of 20 $\mu\text{S}/\text{cm}$.

Depending on the version ordered, the measuring device can also measure potentially explosive, flammable, poisonous and oxidizing media.

Measuring devices for use in hazardous areas, in hygienic applications or in applications where there is an increased risk due to process pressure, are labeled accordingly on the nameplate.

To ensure that the measuring device remains in proper condition for the operation time:

- ▶ Only use the measuring device in full compliance with the data on the nameplate and the general conditions listed in the Operating Instructions and supplementary documentation.
- ▶ Based on the nameplate, check whether the ordered device is permitted for the intended use in the hazardous area (e.g. explosion protection, pressure vessel safety).
- ▶ Use the measuring device only for media against which the process-wetted materials are adequately resistant.
- ▶ If the measuring device is not operated at atmospheric temperature, compliance with the relevant basic conditions specified in the device documentation provided (on the CD-ROM) is absolutely essential.

Incorrect use

Non-designated use can compromise safety. The manufacturer is not liable for damage caused by improper or non-designated use.

WARNING

Danger of breakage of the sensor due to corrosive or abrasive fluids!

- ▶ Verify the compatibility of the process fluid with the sensor material.
- ▶ Ensure the resistance of all fluid-wetted materials in the process.
- ▶ Observe the specified maximum process pressure.

Verification for borderline cases:

- ▶ For special fluids and fluids for cleaning, Endress+Hauser is glad to provide assistance in verifying the corrosion resistance of fluid-wetted materials, but does not accept any warranty or liability as minute changes in the temperature, concentration or level of contamination in the process can alter the corrosion resistance properties.

Residual risks

The external surface temperature of the housing can increase by max. 10 K due to the power consumption of the electronic components. Hot process fluids passing through the measuring device will further increase the surface temperature of the housing. The surface of the sensor, in particular, can reach temperatures which are close to the fluid temperature.

Possible burn hazard due to fluid temperatures!

- ▶ For elevated fluid temperature, ensure protection against contact to prevent burns.

2.3 Workplace safety

For work on and with the device:

- ▶ Wear the required personal protective equipment according to federal/national regulations.

For welding work on the piping:

- ▶ Do not ground the welding unit via the measuring device.

2.4 Operational safety

Risk of injury.

- ▶ Operate the device in proper technical condition and fail-safe condition only.
- ▶ The operator is responsible for interference-free operation of the device.

Conversions to the device

Unauthorized modifications to the device are not permitted and can lead to unforeseeable dangers.

- ▶ If, despite this, modifications are required, consult with Endress+Hauser.

Repair

To ensure continued operational safety and reliability,

- ▶ Carry out repairs on the device only if they are expressly permitted.
- ▶ Observe federal/national regulations pertaining to repair of an electrical device.
- ▶ Use original spare parts and accessories from Endress+Hauser only.

2.5 Product safety

This measuring device is designed in accordance with good engineering practice to meet state-of-the-art safety requirements, has been tested, and left the factory in a condition in which they are safe to operate.

It meets general safety standards and legal requirements. It also complies with the EC directives listed in the device-specific EC Declaration of Conformity. Endress+Hauser confirms this by affixing the CE mark to the device.

3 Product description

3.1 Product design

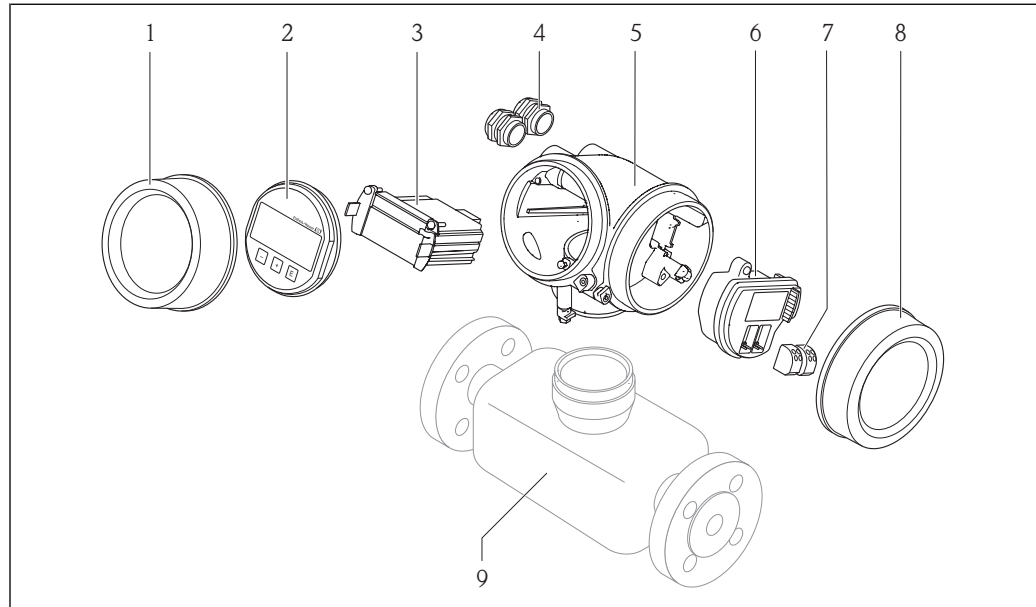

A0014056

 1 Important components of a measuring device

- 1 Electronics compartment cover
- 2 Display module
- 3 Main electronics module
- 4 Cable glands
- 5 Transmitter housing
- 6 I/O electronics module
- 7 Terminals (spring loaded terminals, pluggable)
- 8 Connection compartment cover
- 9 Sensor

3.2 Registered trademarks

HART®

Registered trademark of the HART Communication Foundation, Austin, USA

Applicator®, FieldCare®, Field Xpert™, HistoROM®

Registered or registration-pending trademarks of the Endress+Hauser Group

4 Incoming acceptance and product identification

4.1 Incoming acceptance

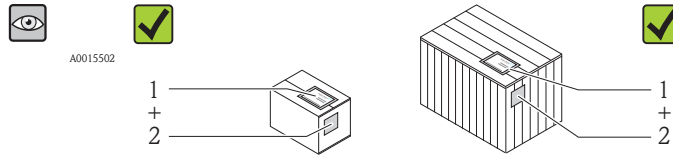

Is the order code on the delivery note (1) identical to the order code on the product sticker (2)?

A0013843

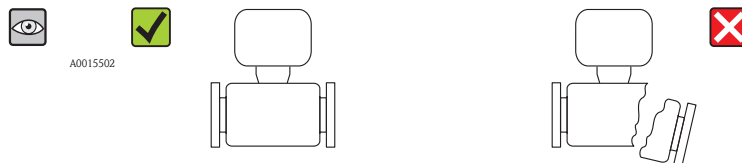
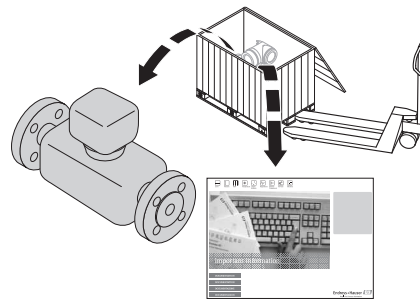

Are the goods undamaged?

A0013698

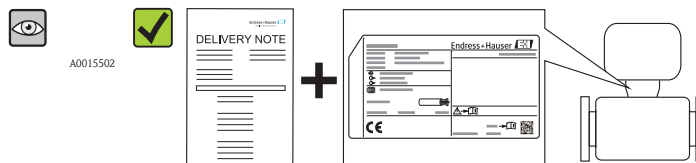

Do the nameplate data match the ordering information on the delivery note?

A0013699

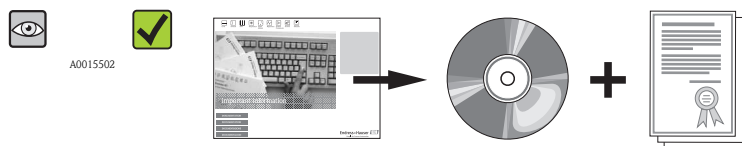

Is the CD-ROM with the Technical Documentation and documents present?

A0013697





If one of the conditions is not satisfied, contact your Endress+Hauser Sales Center.

4.2 Product identification

The following options are available for identification of the measuring device:

- Nameplate specifications
- Order code with breakdown of the device features on the delivery note
- Enter serial numbers from nameplates in *W@M Device Viewer* (www.endress.com/deviceviewer): All information about the measuring device is displayed.

For an overview of the scope of the Technical Documentation provided, refer to the following:

- The "Additional standard documentation on the device" (→  7) and "Supplementary device-dependent documentation" (→  7) sections
- The *W@M Device Viewer*: Enter the serial number from the nameplate (www.endress.com/deviceviewer)

4.2.1 Transmitter nameplate

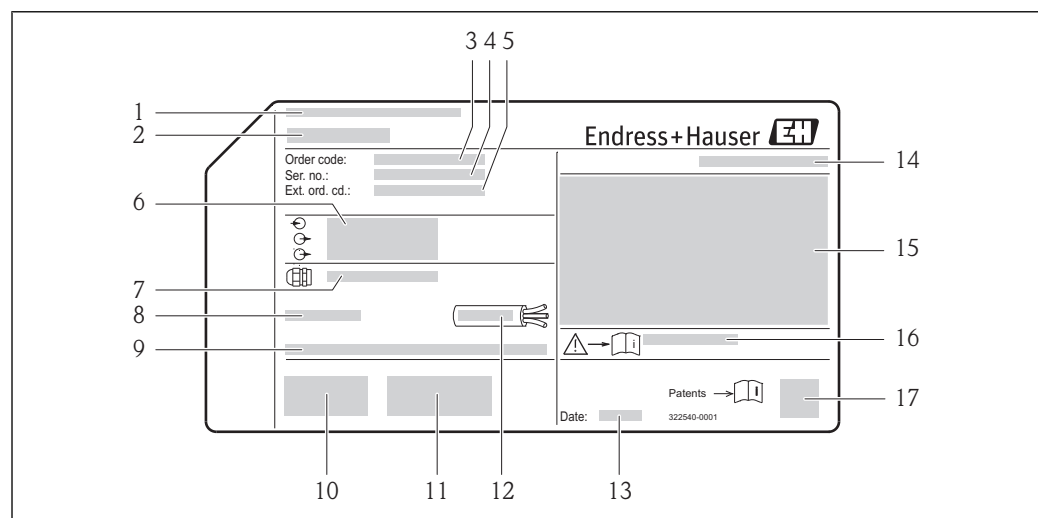

AD013906

 2 Example of a transmitter nameplate

- 1 Manufacturing location
- 2 Name of the transmitter
- 3 Order code
- 4 Serial number
- 5 Extended order code
- 6 Electrical connection data, e.g. available inputs and outputs, supply voltage
- 7 Type of cable glands
- 8 Permitted ambient temperature range (T_a)
- 9 Firmware version (FW) and device revision (Dev.Rev.) from the factory
- 10 CE mark, C-Tick
- 11 Additional information on version: certificates, approvals
- 12 Permitted temperature range for cable
- 13 Manufacturing date: year-month
- 14 Degree of protection
- 15 Explosion protection approval information
- 16 Document number of safety-related supplementary documentation
- 17 2-D matrix code

4.2.2 Sensor nameplate

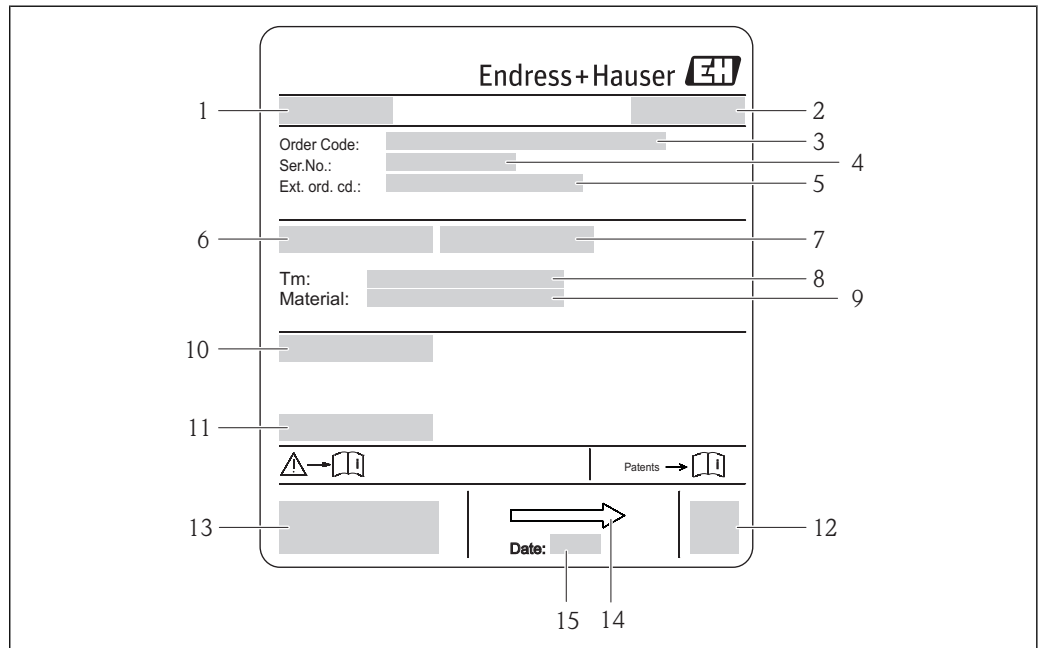

A0017186

 3 Example of sensor nameplate

- 1 Name of the sensor
- 2 Manufacturing location
- 3 Order code
- 4 Serial number (Ser. no.)
- 5 Extended order code (Ext. ord. cd.)
- 6 Nominal diameter of the sensor
- 7 Test pressure of the sensor
- 8 Medium temperature range
- 9 Material of lining and electrodes
- 10 Degree of protection: e.g. IP, NEMA
- 11 Permitted ambient temperature (T_a)
- 12 2-D matrix code
- 13 CE mark, C-Tick
- 14 Flow direction
- 15 Manufacturing date: year-month



Order code

The measuring device is reordered using the order code.

Extended order code

- The device type (product root) and basic specifications (mandatory features) are always listed.
- Of the optional specifications (optional features), only the safety and approval-related specifications are listed (e.g. LA). If other optional specifications are also ordered, these are indicated collectively using the # placeholder symbol (e.g. #LA#).
- If the ordered optional specifications do not include any safety and approval-related specifications, they are indicated by the + placeholder symbol (e.g. XXXXXX-ABCDE+).

4.2.3 Symbols on measuring device

| Symbol | Meaning |
|---|--|
|  | WARNING! This symbol alerts you to a dangerous situation. Failure to avoid this situation can result in serious or fatal injury. |
|  A0011194 | Reference to documentation Refers to the corresponding device documentation. |
|  A0011199 | Protective ground connection A terminal which must be connected to ground prior to establishing any other connections. |

5 Storage and transport

5.1 Storage conditions

Observe the following notes for storage:

- Store in the original packaging to ensure protection from shock.
- Do not remove protective covers or protective caps installed on process connections. They prevent mechanical damage to the sealing surfaces and contamination in the measuring tube.
- Protect from direct sunlight to avoid unacceptably high surface temperatures.
- Select a storage location where moisture cannot collect in the measuring device as fungus and bacteria infestation can damage the lining.
- Store in a dry and dust-free place.
- Do not store outdoors.
- Storage temperature(→ [112](#))

5.2 Transporting the product

⚠ WARNING

Center of gravity of the measuring device is higher than the suspension points of the webbing slings.

Risk of injury if the measuring device slips.

- ▶ Secure the measuring device from rotating or slipping.
- ▶ Observe the weight specified on the packaging (stick-on label).
- ▶ Observe the transport instructions on the stick-on label on the electronics compartment cover.

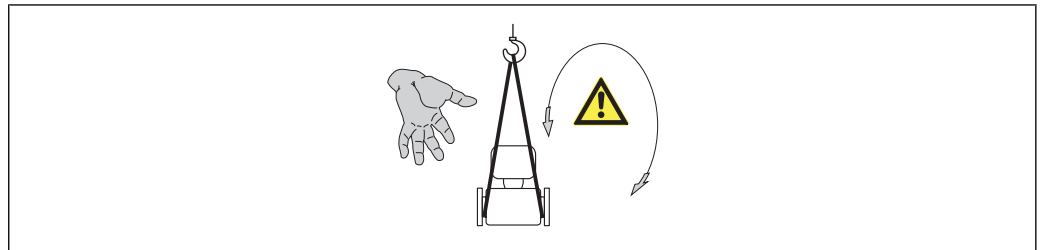

A0015006

Observe the following notes during transport:

- Transport the measuring device to the measuring point in the original packaging.
- Lifting gear
 - Webbing slings: Do not use chains, as they could damage the housing.
 - For wood crates, the floor structure enables these to be loaded lengthwise or broadside using a forklift.
- Use the webbing slings to lift the measuring device at the process connections; do not lift at the transmitter housing.
- Do not remove protective covers or protective caps installed on process connections. They prevent mechanical damage to the sealing surfaces and contamination in the measuring tube.

5.3 Packaging disposal

All packaging materials are environmentally friendly and 100% recyclable:

- Measuring device secondary packaging: polymer stretch film that conforms to EC Directive 2002/95/EC (RoHS).
- Packaging:
 - Wood crate, treated in accordance with ISPM 15 standard, which is confirmed by the affixed IPPC logo.
 - or
 - Carton in accordance with European Packaging Directive 94/62EC; recyclability is confirmed by the affixed RESY symbol.
- Seaworthy packaging (optional): Wood crate, treated in accordance with ISPM 15 standard, which is confirmed by the affixed IPPC logo.
- Carrying and mounting hardware:
 - Disposable plastic pallet
 - Plastic straps
 - Plastic adhesive strips
- Dunnage: Paper cushion

6 Installation

6.1 Installation conditions

No special measures such as supports are necessary. External forces are absorbed by the construction of the device.

6.1.1 Mounting position

Mounting location

Preferably install the sensor in an ascending pipe, and ensure a sufficient distance to the next pipe elbow: $h \geq 2 \times DN$

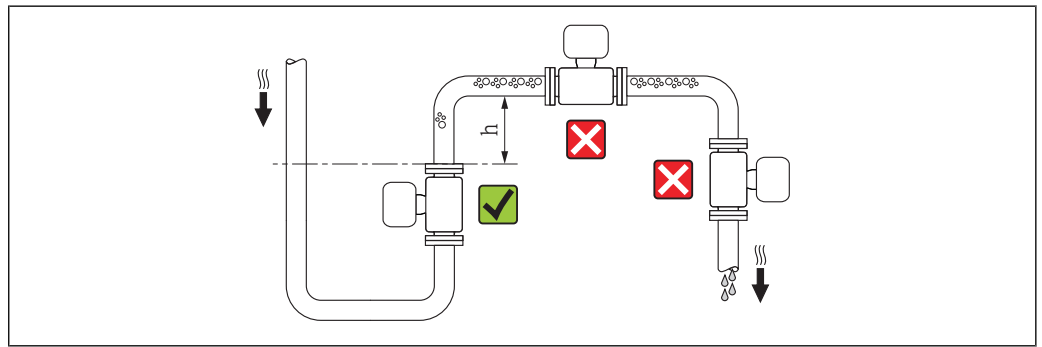



A0017061

To prevent measuring errors arising from accumulation of gas bubbles in the measuring tube, avoid the following mounting locations in the pipe:

- Highest point of a pipeline.
- Directly upstream of a free pipe outlet in a down pipe.

Installation in down pipes

Install a siphon or a vent valve downstream of the sensor in down pipes whose length $h \geq 5 \text{ m}$ (16.4 ft). This precaution is to avoid low pressure and the consequent risk of damage to the measuring tube. This measure also prevents the system losing prime, which could cause air pockets.

 For information on the liner's resistance to partial vacuum (\rightarrow  116)

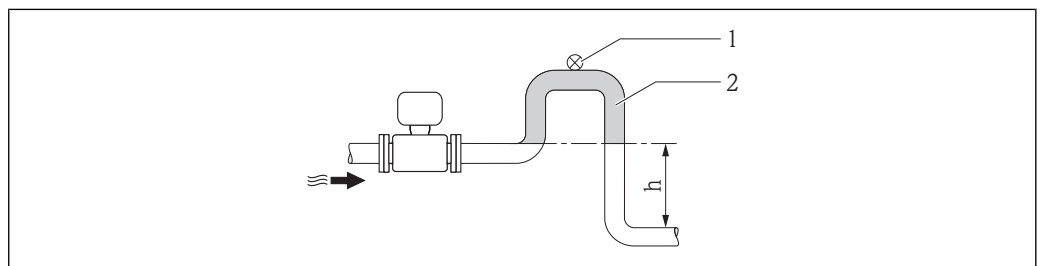

A0017064

 4 Installation in a down pipe

- 1 Vent valve
- 2 Pipe siphon
- h Length of down pipe

Installation in partially filled pipes

A partially filled pipe with a gradient necessitates a drain-type configuration. The empty pipe detection (EPD) function offers additional protection by detecting empty or partially filled pipes.

- Do not install the sensor at the lowest point in the drain: risk of solids accumulating.
- It is advisable to install a cleaning valve.

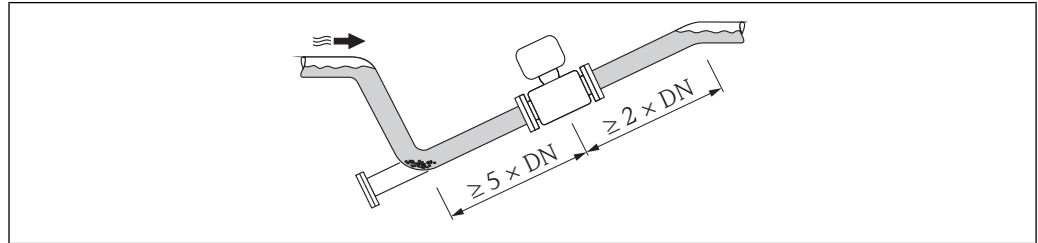

A0017063

Orientation

The direction of the arrow on the sensor nameplate helps you to install the sensor according to the flow direction (direction of medium flow through the piping).

An optimum orientation position helps avoid gas and air accumulations and deposits in the measuring tube.

The measuring device also offers the empty pipe detection function to detect partially empty measuring pipes at outgassing fluids or applications with variable process pressures.

Vertical

This is the optimum orientation for self-emptying piping systems and for use in conjunction with empty pipe detection.

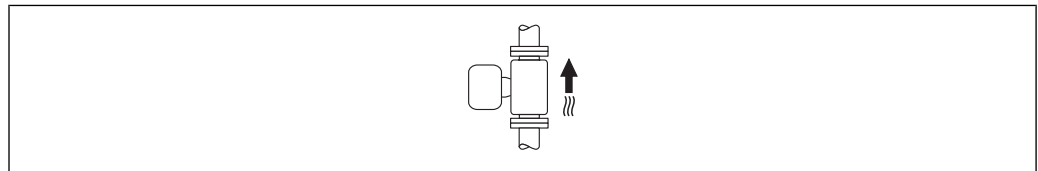

A0015591

Horizontal

The measuring electrode plane must be horizontal. This prevents brief insulation of the two measuring electrodes by entrained air bubbles.

- i** With horizontal orientation, empty pipe detection only works if the transmitter housing is pointing upwards as otherwise there is no guarantee that the empty pipe detection function will actually respond to a partially filled or empty measuring tube.

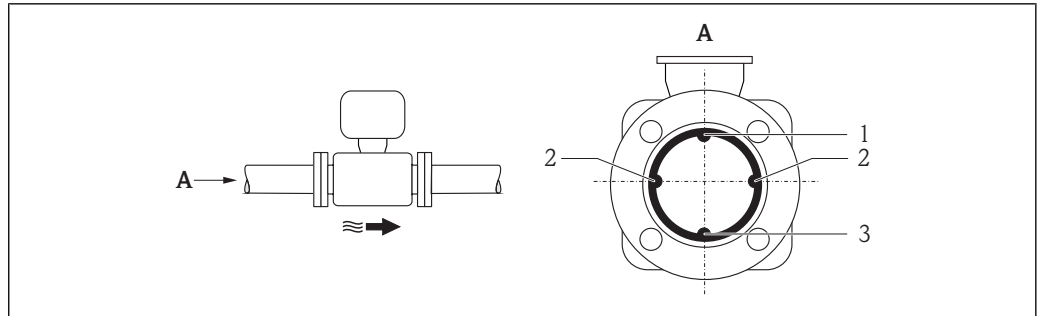

A0016260

5 Horizontal orientation

- 1 EPD electrode for empty pipe detection
- 2 Measuring electrodes for signal detection
- 3 Reference electrode for potential equalization

Inlet and outlet runs

If possible, install the sensor upstream from fittings such as valves, T-pieces or elbows.

Observe the following inlet and outlet runs to comply with accuracy specifications:

- Inlet run $\geq 5 \times DN$
- Outlet run $\geq 2 \times DN$

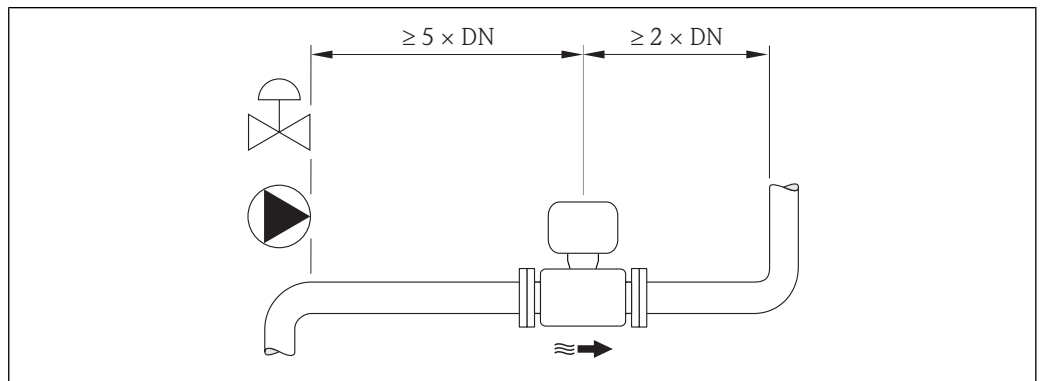

A0016275

Installation dimensions

For the dimensions and installation lengths of the device, see the "Technical Information" document, "Mechanical construction" section

6.1.2 Requirements from environment and process

Ambient temperature range

| | |
|---------------|---|
| Transmitter | -40 to +60 °C (-40 to +140 °F) |
| Local display | -20 to +60 °C (-4 to +140 °F), the readability of the display may be impaired at temperatures outside the temperature range. |
| Sensor | <ul style="list-style-type: none"> ■ Flange material carbon steel: -10 to +60 °C (+14 to +140 °F) ■ Flange material stainless steel: -40 to +60 °C (-40 to +140 °F) |
| Liner | Do not exceed or fall below the permitted temperature range of the liner (→ 113). |

If operating outdoors:

- Install the measuring device in a shady location.
- Avoid direct sunlight, particularly in warm climatic regions.
- Avoid direct exposure to weather conditions.

System pressure

- Never install the sensor on the pump suction side in order to avoid the risk of low pressure, and thus damage to the liner.
- Furthermore, install pulse dampers if reciprocating, diaphragm or peristaltic pumps are used.

- i** ■ For information on the liner's resistance to partial vacuum (→ 116)
- For information on the measuring system's resistance to vibration and shock (→ 113), (→ 113)

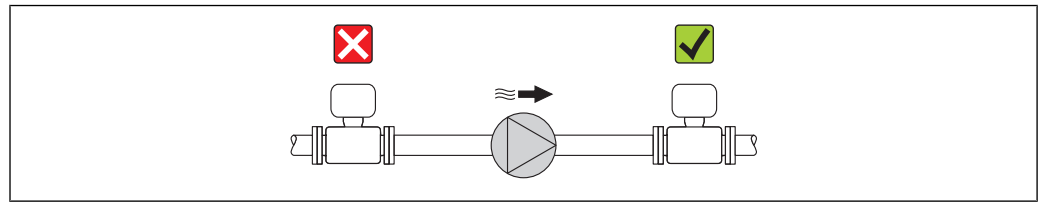

A0015594

Vibrations

In the event of very strong vibrations, the pipe and sensor must be supported and fixed.

- i** For information on the permitted resistance to vibration and shock (→ 113), (→ 113)

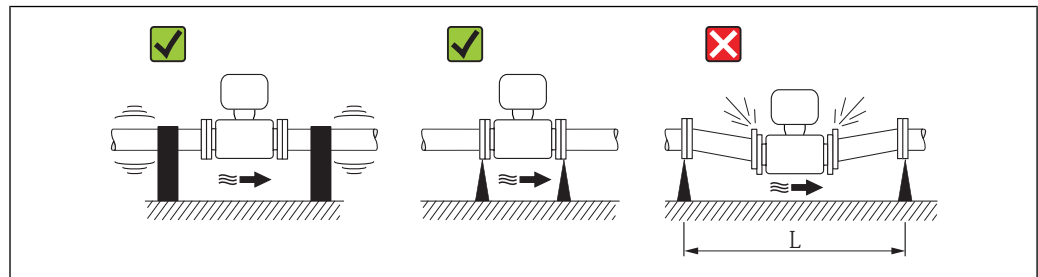

A0016266

6 Measures to prevent vibration of the device

$L > 10\text{ m (33 ft)}$

Adapters

Suitable adapters to DIN EN 545 (double-flange reducers) can be used to install the sensor in larger-diameter pipes. The resultant increase in the rate of flow improves measuring accuracy with very slow-moving fluids. The nomogram shown here can be used to calculate the pressure loss caused by reducers and expanders.

- i** The nomogram only applies to liquids with a viscosity similar to that of water.

1. Calculate the ratio of the diameters d/D .
2. From the nomogram read off the pressure loss as a function of flow velocity (downstream from the reduction) and the d/D ratio.

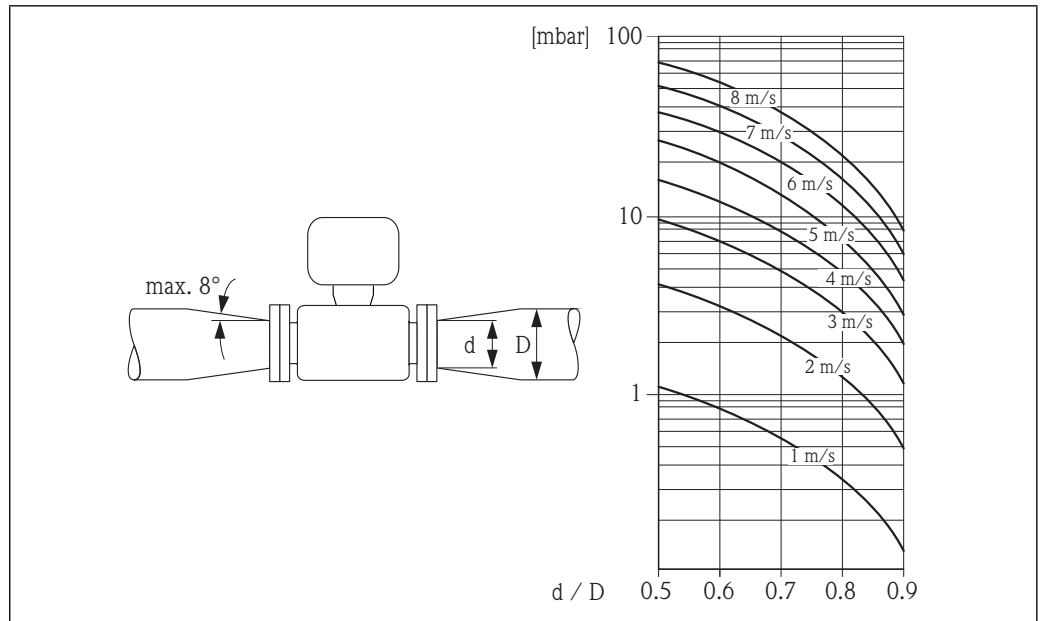

A0016359

6.1.3 Special mounting instructions

Weather protection cover

- To ensure that the optional weather protection cover can be easily opened, maintain the following minimum head clearance: 350 mm (13.8 in)

6.2 Mounting the measuring device

6.2.1 Required tools

For transmitter

- For turning the transmitter housing: Open-ended wrench 8 mm
- For opening the securing clamps: Allen key 3 mm

For sensor

For flanges and other process connections:

- Screws, nuts, seals etc. are not included in the scope of supply and must be provided by the customer.
- Appropriate mounting tools

6.2.2 Preparing the measuring device

1. Remove all remaining transport packaging.
2. Remove any protective covers or protective caps present from the sensor.
3. Remove stick-on label on the electronics compartment cover.

6.2.3 Mounting the sensor

⚠ WARNING

Danger due to improper process sealing!

- ▶ Ensure that the inside diameters of the gaskets are greater than or equal to that of the process connections and piping.
- ▶ Ensure that the gaskets are clean and undamaged.
- ▶ Install the gaskets correctly.

1. Ensure that the direction of the arrow on the sensor matches the flow direction of the medium.
2. To ensure compliance with device specifications, install the measuring device between the pipe flanges in a way that it is centered in the measurement section.
3. If using ground disks, comply with the Installation Instructions provided.
4. Observe required screw tightening torques (→ 22).
5. Install the measuring device or turn the transmitter housing so that the cable entries do not point upwards.

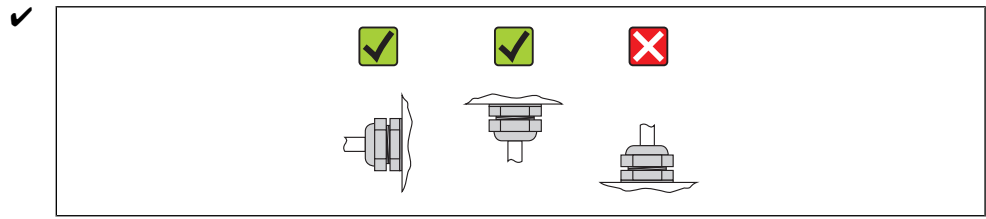

A0013964

Mounting the seals

⚠ CAUTION

An electrically conductive layer could form on the inside of the measuring tube!

Risk of measuring signal short circuit.

- ▶ Do not use electrically conductive sealing compounds such as graphite.

Comply with the following instructions when installing seals:

- Make sure that the seals do not protrude into the piping cross-section.
- For DIN flanges: only use seals according to DIN EN 1514-1.
- For "PFA" lining: additional seals are **always** required.
- For "PTFE" lining: generally additional seals are **not** required.

Mounting the ground cable/ground disks

Comply with the information on potential equalization and detailed mounting instructions for the use of ground cables/ground disks (→ 30).

Screw tightening torques

Please note the following:

- The screw tightening torques listed below apply only to lubricated threads and to pipes not subjected to tensile stress.
- Tighten the screws uniformly and in diagonally opposite sequence.
- Overtightening the screws will deform the sealing faces or damage the seals.

Screw tightening torques for EN 1092-1 (DIN 2501), PN 40/25

| Nominal diameter [mm] | Pressure rating [bar] | Threaded fasteners [mm] | Max. screw tightening torque [Nm] | |
|--------------------------|--------------------------|----------------------------|-----------------------------------|-----|
| | | | PTFE | PFA |
| 25 | PN 40 | 4 × M12 | 26 | 20 |
| 32 | PN 40 | 4 × M16 | 41 | 35 |
| 40 | PN 40 | 4 × M16 | 52 | 47 |

| Nominal diameter [mm] | Pressure rating [bar] | Threaded fasteners [mm] | Max. screw tightening torque [Nm] | |
|--------------------------|--------------------------|----------------------------|-----------------------------------|-----|
| | | | PTFE | PFA |
| 50 | PN 40 | 4 × M16 | 65 | 59 |
| 65 ¹⁾ | PN 16 | 8 × M16 | 43 | 40 |
| 65 | PN 40 | 8 × M16 | 43 | 40 |
| 80 | PN 16 | 8 × M16 | 53 | 48 |
| 80 | PN 40 | 8 × M16 | 53 | 48 |
| 100 | PN 16 | 8 × M16 | 57 | 51 |
| 100 | PN 40 | 8 × M20 | 78 | 70 |
| 125 | PN 16 | 8 × M16 | 75 | 67 |
| 125 | PN 40 | 8 × M24 | 111 | 99 |
| 150 | PN 16 | 8 × M20 | 99 | 85 |
| 150 | PN 40 | 8 × M24 | 136 | 120 |
| 200 | PN 10 | 8 × M20 | 141 | 101 |
| 200 | PN 16 | 12 × M20 | 94 | 67 |
| 200 | PN 25 | 12 × M24 | 138 | 105 |

1) Designed acc. to EN 1092-1 (not to DIN 2501)

Screw tightening torques for ASME B16.5, Class 150/300

| Nominal diameter | | Pressure rating [psi] | Threaded fasteners [in] | Max. screw tightening torque [Nm] ([lbf · ft]) | |
|------------------|------|--------------------------|----------------------------|--|----------|
| [mm] | [in] | | | PTFE | PFA |
| 25 | 1 | Class 150 | 4 × ½ | 11 (8) | 10 (7) |
| 25 | 1 | Class 300 | 4 × 5/8 | 14 (10) | 12 (9) |
| 40 | 1 ½ | Class 150 | 4 × ½ | 24 (18) | 21 (15) |
| 40 | 1 ½ | Class 300 | 4 × ¾ | 34 (25) | 31 (23) |
| 50 | 2 | Class 150 | 4 × 5/8 | 47 (35) | 44 (32) |
| 50 | 2 | Class 300 | 8 × 5/8 | 23 (17) | 22 (16) |
| 80 | 3 | Class 150 | 4 × 5/8 | 79 (58) | 67 (49) |
| 80 | 3 | Class 300 | 8 × ¾ | 47 (35) | 42 (31) |
| 100 | 4 | Class 150 | 8 × 5/8 | 56 (41) | 50 (37) |
| 100 | 4 | Class 300 | 8 × ¾ | 67 (49) | 59 (44) |
| 150 | 6 | Class 150 | 8 × ¾ | 106 (78) | 86 (63) |
| 150 | 6 | Class 300 | 12 × ¾ | 73 (54) | 67 (49) |
| 200 | 8 | Class 150 | 8 × ¾ | 143 (105) | 109 (80) |

Screw tightening torques for AS 2129, Table E

| Nominal diameter [mm] | Threaded fasteners [mm] | Max. screw tightening torque [Nm] |
|--------------------------|----------------------------|-----------------------------------|
| | | PTFE |
| 25 | 4 × M12 | 21 |
| 50 | 4 × M16 | 42 |

Screw tightening torques for AS 4087, PN 16

| Nominal diameter [mm] | Threaded fasteners [mm] | Max. screw tightening torque [Nm] | |
|--------------------------|----------------------------|-----------------------------------|--|
| | | PTFE | |
| 50 | 4 × M16 | 42 | |

Screw tightening torques for JIS B2220, 10/20K

| Nominal diameter [mm] | Pressure rating [bar] | Threaded fasteners [mm] | Max. screw tightening torque [Nm] | |
|--------------------------|--------------------------|----------------------------|-----------------------------------|-----|
| | | | PTFE | PFA |
| 25 | 10K | 4 × M16 | 32 | 27 |
| 25 | 20K | 4 × M16 | 32 | 27 |
| 32 | 10K | 4 × M16 | 38 | – |
| 32 | 20K | 4 × M16 | 38 | – |
| 40 | 10K | 4 × M16 | 41 | 37 |
| 40 | 20K | 4 × M16 | 41 | 37 |
| 50 | 10K | 4 × M16 | 54 | 46 |
| 50 | 20K | 8 × M16 | 27 | 23 |
| 65 | 10K | 4 × M16 | 74 | 63 |
| 65 | 20K | 8 × M16 | 37 | 31 |
| 80 | 10K | 8 × M16 | 38 | 32 |
| 80 | 20K | 8 × M20 | 57 | 46 |
| 100 | 10K | 8 × M16 | 47 | 38 |
| 100 | 20K | 8 × M20 | 75 | 58 |
| 125 | 10K | 8 × M20 | 80 | 66 |
| 125 | 20K | 8 × M22 | 121 | 103 |
| 150 | 10K | 8 × M20 | 99 | 81 |
| 150 | 20K | 12 × M22 | 108 | 72 |
| 200 | 10K | 12 × M20 | 82 | 54 |
| 200 | 20K | 12 × M22 | 121 | 88 |

6.2.4 Turning the transmitter housing

To provide easier access to the connection compartment or display module, the transmitter housing can be turned:

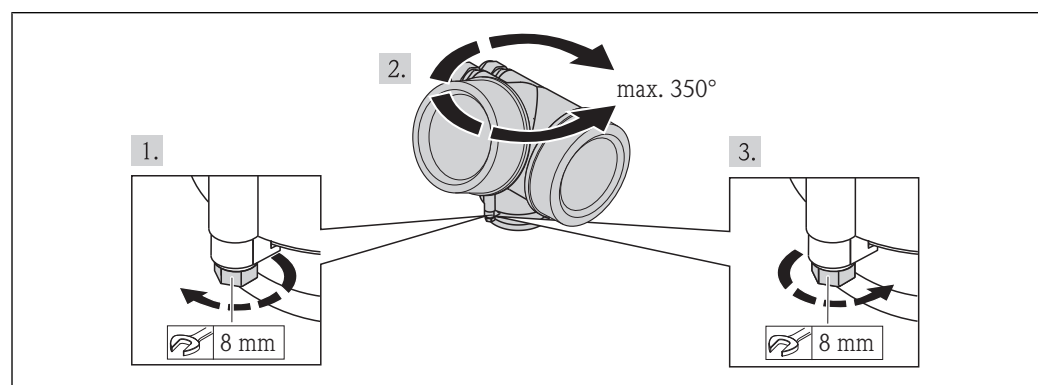

A0013713

1. Release the fixing screw.
2. Turn the housing to the desired position.
3. Firmly tighten the securing screw.

6.2.5 Turning the display module

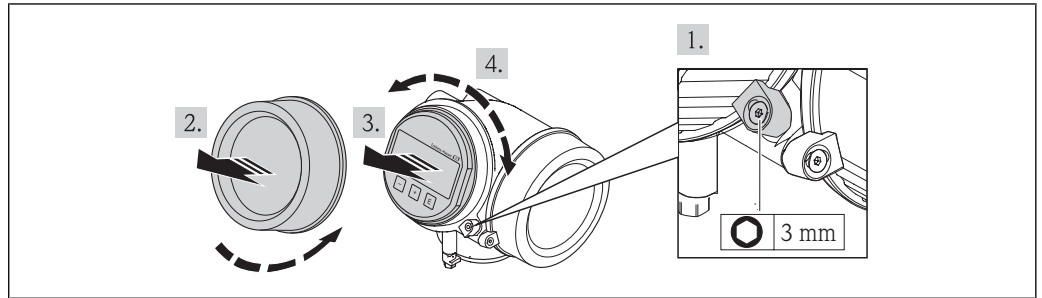

1. Loosen the securing clamp of the electronics compartment cover using an Allen key.
2. Unscrew cover of the electronics compartment from the transmitter housing.
3. Optional: pull out the display module with a gentle rotational movement.
4. Rotate the display module into the desired position: Max. $8 \times 45^\circ$ in each direction.
5. Without display module pulled out:
Allow display module to engage at desired position.
6. With display module pulled out:
Feed the spiral cable into the gap between the housing and main electronics module and plug the display module into the electronics compartment until it engages.
7. Reverse the removal procedure to reassemble the transmitter.

6.3 Post-installation check

| | |
|---|--------------------------|
| Is the device undamaged (visual inspection)? | <input type="checkbox"/> |
| Does the measuring device conform to the measuring point specifications? For example: <ul style="list-style-type: none"> ■ Process temperature ■ Process pressure (refer to the section on "Pressure-temperature ratings" in the "Technical Information" document) ■ Ambient temperature range ■ Measuring range | <input type="checkbox"/> |
| Has the correct orientation for the sensor been selected (→ 18)? <ul style="list-style-type: none"> ■ According to sensor type ■ According to medium temperature ■ According to medium properties (outgassing, with entrained solids) | <input type="checkbox"/> |
| Does the arrow on the sensor nameplate match the direction of flow of the fluid through the piping (→ 18)? | <input type="checkbox"/> |
| Are the measuring point identification and labeling correct (visual inspection)? | <input type="checkbox"/> |
| Is the device adequately protected from precipitation and direct sunlight? | <input type="checkbox"/> |
| Have the fixing screws been tightened with the correct tightening torque? | <input type="checkbox"/> |

7 Electrical connection

7.1 Connection conditions

7.1.1 Required tools

- For cable entries: Use corresponding tools
- For securing clamp: Allen key 3 mm
- Wire stripper
- When using stranded cables: Crimping tool for wire end ferrule
- For removing cables from terminal: Flat blade screwdriver ≤ 3 mm (0.12 in)

7.1.2 Requirements for connecting cable

The connecting cables provided by the customer must fulfill the following requirements.

Electrical safety

In accordance with applicable federal/national regulations.

Permitted temperature range

- -40 °C (-40 °F)... ≥ 80 °C (176 °F)
- Minimum requirement: cable temperature range \geq ambient temperature + 20 K

Signal cable

Current output

- For 4-20 mA: standard installation cable is sufficient.
- For 4-20 mA HART: Shielded cable recommended. Observe grounding concept of the plant.

Pulse/frequency/switch output

Standard installation cable is sufficient.

Cable diameter

- Included cable glands: M20 \times 1.5 with cable \varnothing 6 to 12 mm (0.24 to 0.47 in)
- Plug-in spring terminals for device version without integrated overvoltage protection: wire cross-sections 0.5 to 2.5 mm² (20 to 14 AWG)
- Screw terminals for device version with integrated overvoltage protection: wire cross-sections 0.2 to 2.5 mm² (24 to 14 AWG)

7.1.3 Terminal assignment

Transmitter

4-20 mA HART connection version with additional outputs

| | |
|---|--|
| | |
| <p>Maximum number of terminals, without integrated overvoltage protection</p> | <p>Maximum number of terminals, with integrated overvoltage protection</p> |
| <p>1 Output 1 (passive): supply voltage and signal transmission 2 Output 2 (passive): supply voltage and signal transmission 3 Ground terminal for cable shield</p> | |

| Order code for "Output" | Terminal numbers | | | |
|-------------------------|------------------------|-------|---|-------|
| | Output 1 | | Output 2 | |
| | 1 (+) | 2 (-) | 3 (+) | 4 (-) |
| Option A | 4-20 mA HART (passive) | | - | |
| Option B ¹⁾ | 4-20 mA HART (passive) | | Pulse/frequency/switch output (passive) | |

1) Output 1 must always be used; output 2 is optional.

7.1.4 Requirements for the supply unit

Supply voltage

An external power supply is required for each output. The following supply voltage values apply for the 4-20 mA HART current output:

| Order code for "Output" | Minimum terminal voltage ^{1) 2)} | Maximum terminal voltage |
|---|---|--------------------------|
| <ul style="list-style-type: none"> ■ Option A: 4-20 mA HART ■ Option B: 4-20 mA HART, pulse/frequency/switch output | For 4 mA: ≥ DC18 V For 20 mA: ≥ DC14 V | DC 35 V |

1) External supply voltage of the power supply unit with load (→ 27)

2) For device versions with local display SD03: The terminal voltage must be increased by DC 2 V if backlighting is used.

Load

Load for current output: 0 to 500 Ω, depending on the external supply voltage of the power supply unit

Calculation of the maximum load

Depending on the supply voltage of the power supply unit (U_S), the maximum load (R_B) including line resistance must be observed to ensure adequate terminal voltage at the device. In doing so, observe the minimum terminal voltage (→ 27)

- For $U_S = 18$ to 18.9 V: $R_B \leq (U_S - 18 \text{ V}) : 0.0036 \text{ A}$
- For $U_S = 18.9$ to 24.5 V: $R_B \leq (U_S - 13.5 \text{ V}) : 0.022 \text{ A}$
- For $U_S = 24.5$ to 30 V: $R_B \leq 500 \Omega$

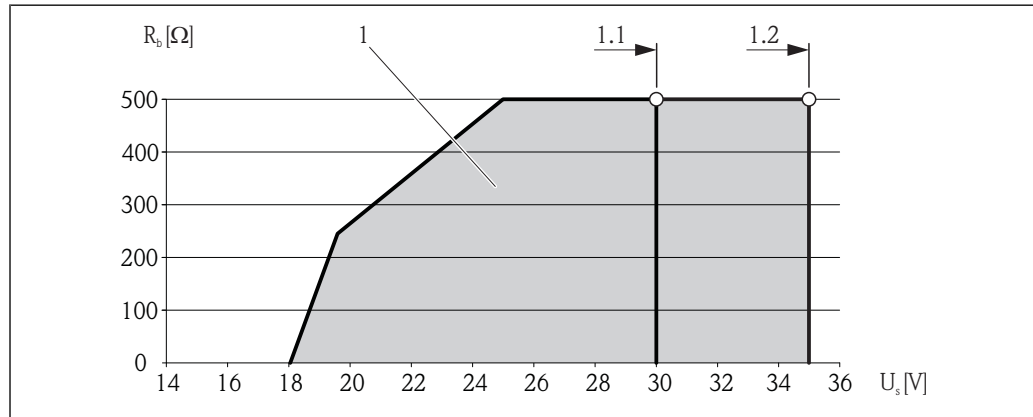

1 Operating range

1.1 For order code for "Output", option A "4-20 mA HART"/option B "4-20 mA HART, pulse/frequency/switch output" with Ex i

1.2 For order code for "Output", option A "4-20 mA HART"/option B "4-20 mA HART, pulse/frequency/switch output" with non-Ex and Ex d

Sample calculation

Supply voltage of the power supply unit: $U_S = 19 \text{ V}$

Maximum load: $R_B \leq (19 \text{ V} - 13.5 \text{ V}) : 0.022 \text{ A} = 250 \Omega$

7.1.5 Preparing the measuring device

1. Remove dummy plug if present.
2. **NOTICE!** Insufficient sealing of the housing! Operational reliability of the measuring device could be compromised. Use suitable cable glands corresponding to the degree of protection. If measuring device is delivered without cable glands: Provide suitable cable gland for corresponding connecting cable (→ 26).
3. If measuring device is delivered with cable glands: Observe cable specification (→ 26).

7.2 Connecting the measuring device

NOTICE

Limitation of electrical safety due to incorrect connection!

- ▶ Have electrical connection work carried out by correspondingly trained specialists only.
- ▶ Observe applicable federal/national installation codes and regulations.
- ▶ Comply with local workplace safety regulations.
- ▶ For use in potentially explosive atmospheres, observe the information in the device-specific Ex documentation.

7.2.1 Connecting the transmitter

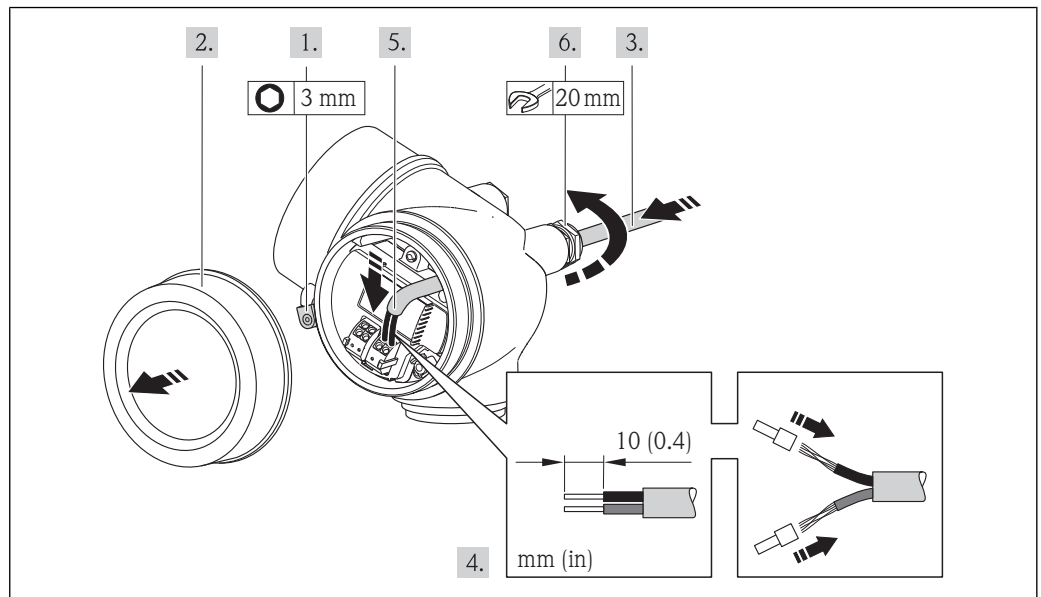

A0013836

1. Loosen the securing clamp of the connection compartment cover.
2. Unscrew the connection compartment cover.
3. Push the cable through the cable entry. To ensure tight sealing, do not remove the sealing ring from the cable entry.
4. Strip the cable and cable ends. In the case of stranded cables, also fit ferrules.
5. Connect the cable in accordance with the terminal assignment (→ 27). For HART communication: When connecting the cable shielding to the ground terminal, observe the grounding concept of the facility.
6. Firmly tighten the cable glands.
7. **NOTICE!** Housing degree of protection voided due to insufficient sealing of the housing. Screw in the screw without using any lubricant. The threads on the cover are coated with a dry lubricant.
Reverse the removal procedure to reassemble the transmitter.

Removing a cable

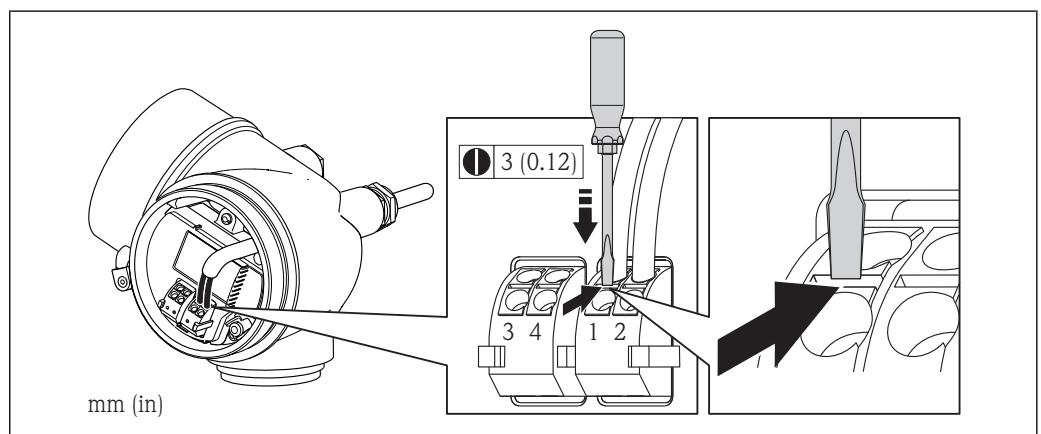

A0013835

- To remove a cable from the terminal, use a slotted screwdriver to push the slot between the two terminal holes while simultaneously pulling the cable end out of the terminal.

7.2.2 Ensuring potential equalization

CAUTION

Electrode damage can result in the complete failure of the device!

- ▶ Make sure that the fluid and sensor have the same electrical potential.
- ▶ Pay attention to internal grounding concepts in the company.
- ▶ Pay attention to the pipe material or grounding.

Connection examples for standard situations

Metal, grounded pipe

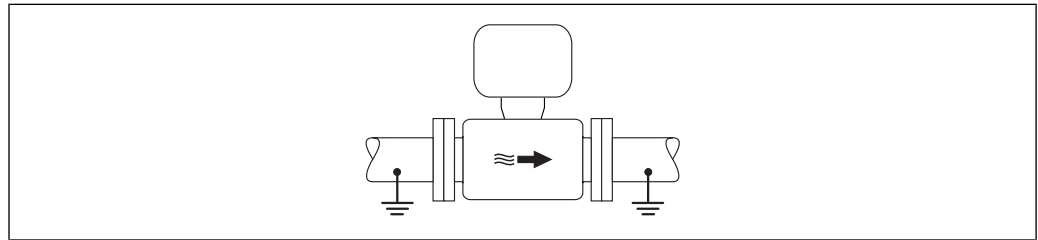

A0016315

 7 *Potential equalization via measuring tube*

Connection example in special situations

Unlined and ungrounded metal pipe

This connection method also applies in situations where:

- The customary potential equalization is not used
- Equalizing currents are present

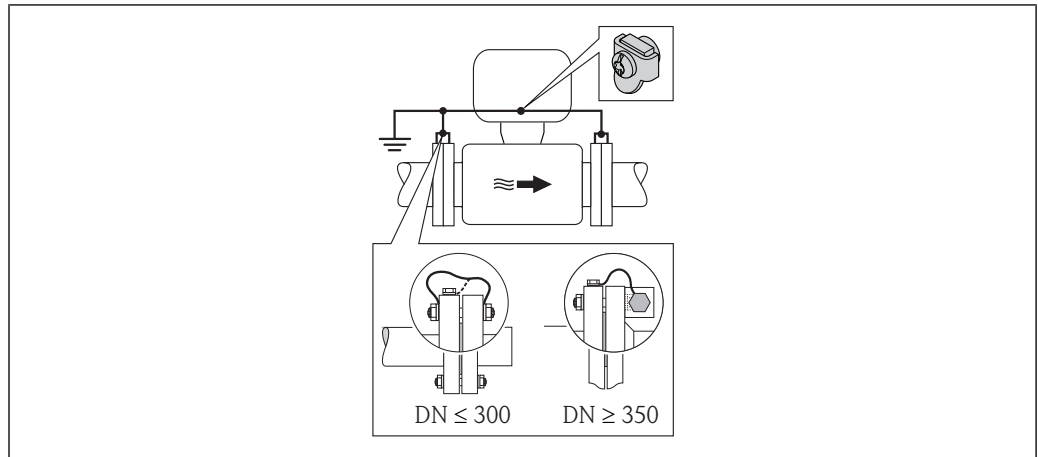

A0016317

 8 *Potential equalization via ground terminal and pipe flanges*

| | |
|---------------------|---|
| Ground cable | Copper wire, at least 6 mm ² (0.0093 in ²) |
|---------------------|---|

1. Connect both sensor flanges to the pipe flange via a ground cable and ground them.
2. If DN ≤ 300 (12"): Mount the ground cable directly on the conductive flange coating of the sensor with the flange screws. If DN ≥ 350 (14"): Mount the ground cable directly on the metal transport bracket. Observe torques (→  22).
3. Connect the connection housing of the transmitter or sensor to ground potential by means of the ground terminal provided for the purpose.

Plastic pipe or pipe with insulating liner

This connection method also applies in situations where:

- The customary potential equalization is not used
- Equalizing currents are present

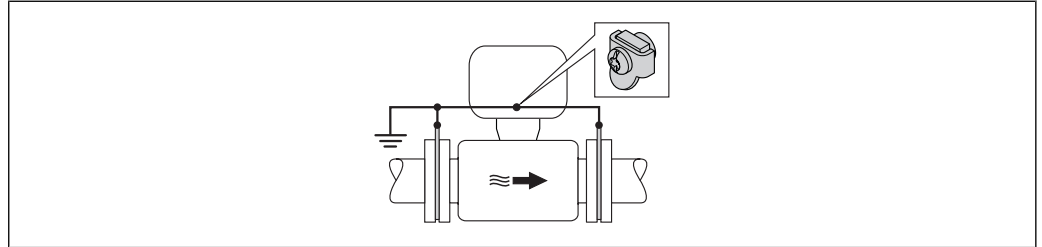

A0016318

9 Potential equalization via ground terminal and ground disks

1. Connect the ground disks to the ground terminal via the ground cable.
2. Connect the ground disks to ground potential.

| | |
|---------------------|---|
| Ground cable | Copper wire, at least 6 mm ² (0.0093 in ²) |
|---------------------|---|

Pipe with a cathodic protection unit

This connection method is only used if the following two conditions are met:

- Metal pipe without liner or pipe with electrically conductive liner
- Cathodic protection is integrated in the personal protection equipment

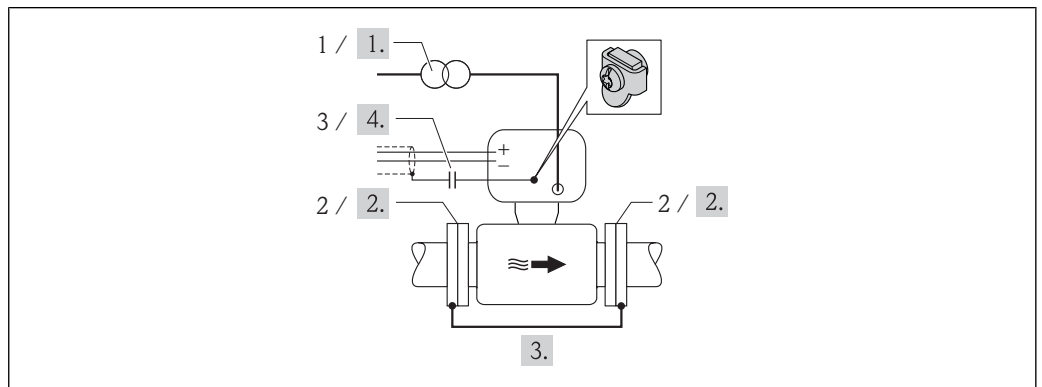

A0016319

10 Potential equalization and cathodic protection

- 1 Isolation transformer power supply
- 2 Electrically isolated from the pipe
- 3 Capacitor

| | |
|---------------------|---|
| Ground cable | Copper wire, at least 6 mm ² (0.0093 in ²) |
|---------------------|---|

1. Connect the measuring device to the power supply such that it is floating in relation to the protective ground.
2. Install the sensor in the pipe in a way that provides electrical insulation.
3. Connect the two flanges of the pipe to one another via a ground cable.
4. Guide the shield of the signal lines through a capacitor.

7.3 Ensuring the degree of protection

The measuring device fulfills all the requirements for the IP66/67 degree of protection, Type 4X enclosure.

To guarantee IP66/67 degree of protection, Type 4X enclosure, carry out the following steps after the electrical connection:

1. Check that the housing seals are clean and fitted correctly. Dry, clean or replace the seals if necessary.
2. Tighten all housing screws and screw covers.
3. Firmly tighten the cable glands.
4. To ensure that moisture does not enter the cable entry, route the cable so that it loops down before the cable entry ("water trap").

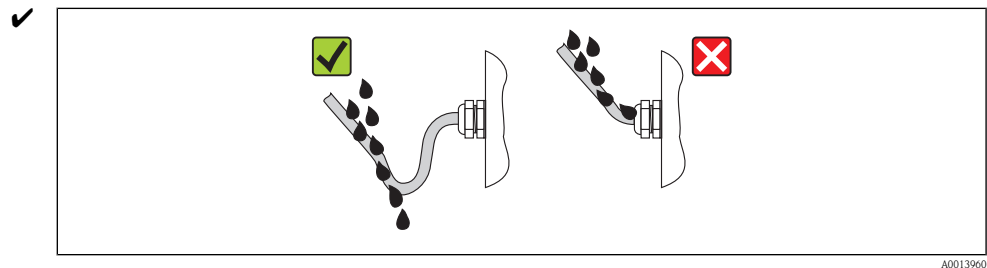

5. Insert dummy plugs into unused cable entries.

7.4 Post-connection check

| | |
|---|--------------------------|
| Are cables or the device undamaged (visual inspection)? | <input type="checkbox"/> |
| Do the cables comply with the requirements (→ 26)? | <input type="checkbox"/> |
| Do the cables have adequate strain relief? | <input type="checkbox"/> |
| Are all the cable glands installed, firmly tightened and leak-tight? Cable run with "water trap" (→ 32) ? | <input type="checkbox"/> |
| Does the supply voltage match the specifications on the transmitter nameplate (→ 27)? | <input type="checkbox"/> |
| Is the terminal assignment correct (→ 27)? | <input type="checkbox"/> |
| If supply voltage is present, do values appear on the display module? | <input type="checkbox"/> |
| Is the potential equalization established correctly (→ 30)? | <input type="checkbox"/> |
| Are all housing covers installed and firmly tightened? | <input type="checkbox"/> |
| Is the securing clamp tightened correctly? | <input type="checkbox"/> |

8 Operation options

8.1 Overview of operation options

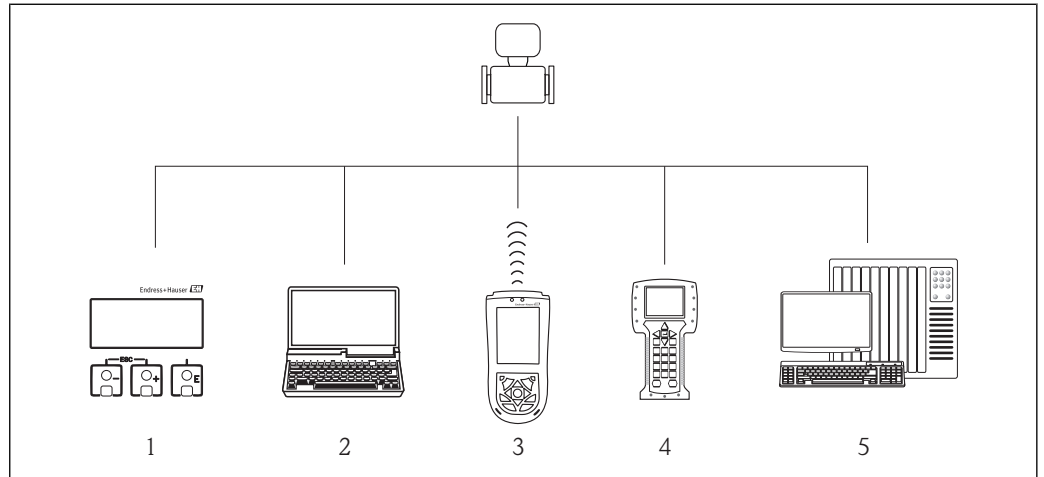

- 1 Local operation via display module
- 2 Computer with operating tool (e.g. FieldCare, AMS Device Manager, SIMATIC PDM)
- 3 Field Xpert SFX100
- 4 Field Communicator 475
- 5 Control system (e.g. PLC)

8.2 Structure and function of the operating menu

8.2.1 Structure of the operating menu

 For an overview of the operating menu with menus and parameters

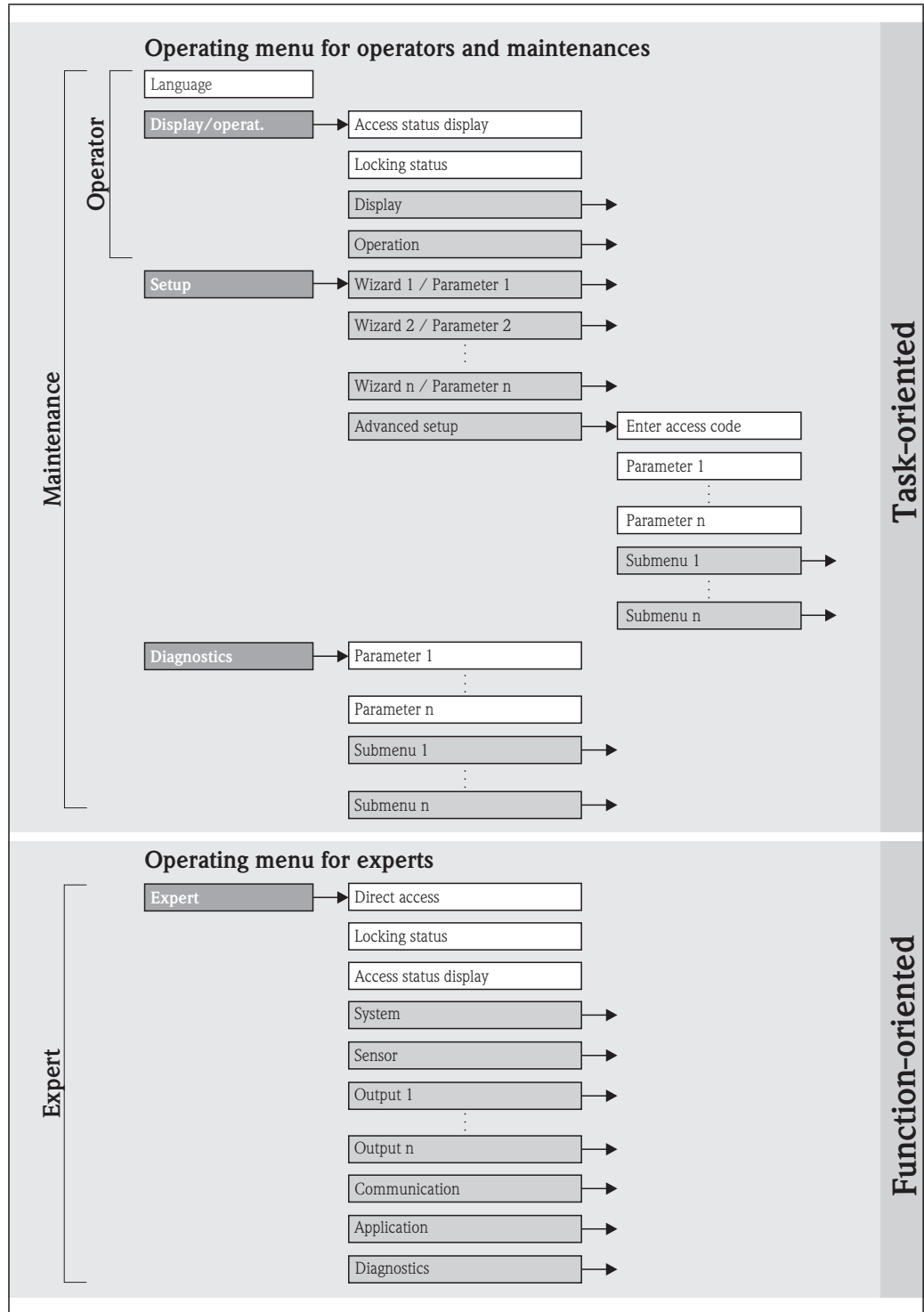

A0018237-EN

 11 Illustrated using the example of the local display

8.2.2 Operating philosophy

The individual parts of the operating menu are assigned to certain user roles. Each user role corresponds to typical tasks within the device lifecycle.

| Menu | | User role and tasks | Content/meaning |
|-----------------|-------------------|--|---|
| Language | task-oriented | Role "Operator", "Maintenance" Tasks during operation: <ul style="list-style-type: none"> ■ Configuring the operational display ■ Reading measured values | Defining the operating language <ul style="list-style-type: none"> ■ Configuring the operational display (e.g. display format, display contrast) ■ Resetting and controlling totalizers |
| Display/operat. | | "Maintenance" role Commissioning: <ul style="list-style-type: none"> ■ Configuration of the measurement ■ Configuration of the outputs | Wizards for quick commissioning: <ul style="list-style-type: none"> ■ Configuring the outputs ■ Configuring the operational display ■ Defining the output conditioning ■ Empty pipe detection ■ Configuring the low flow cut off "Advanced setup" submenu: <ul style="list-style-type: none"> ■ For more customized configuration of the measurement (adaptation to special measuring conditions) ■ Configuration of totalizers ■ Configuration of electrode cleaning (optional) |
| Setup | | "Maintenance" role Fault elimination: <ul style="list-style-type: none"> ■ Diagnostics and elimination of process and device errors ■ Measured value simulation | Contains all parameters for error detection and analyzing process and device errors: <ul style="list-style-type: none"> ■ "Diagnostic list" submenu Contains up to 5 currently pending diagnostic messages. ■ "Event logbook" submenu Contains up to 20 or 100 (order option) event messages that have occurred. ■ "Device information" submenu Contains information for identifying the device. ■ "Measured values" submenu Contains all current measured values. ■ "Data logging" submenu (order option) Storage and visualization of up to 1000 measured values ■ "Simulation" submenu Is used to simulate measured values or output values. ■ "Device reset" submenu Resets the device configuration to certain settings |
| Diagnosics | function-oriented | Tasks that require detailed knowledge of the function of the device: <ul style="list-style-type: none"> ■ Commissioning measurements under difficult conditions ■ Optimal adaptation of the measurement to difficult conditions ■ Detailed configuration of the communication interface ■ Error diagnostics in difficult cases | Contains all the parameters of the device and makes it possible to access these parameters directly using an access code. The structure of this menu is based on the function blocks of the device: <ul style="list-style-type: none"> ■ "System" submenu Contains all higher-order device parameters that do not pertain either to measurement or the measured value communication. ■ "Sensor" submenu Contains all parameters for configuring the measurement. ■ "Output" submenu Contains all parameters for configuring the analog current outputs. ■ "Communication" submenu Contains all parameters for configuring the digital communication interface. ■ "Application" submenu Contains all parameters for configuring the functions that go beyond the actual measurement (e.g. totalizer). ■ "Diagnostics" submenu Contains all parameters for error detection and analyzing process and device errors and for device simulation. |
| Expert | | Tasks that require detailed knowledge of the function of the device: <ul style="list-style-type: none"> ■ Commissioning measurements under difficult conditions ■ Optimal adaptation of the measurement to difficult conditions ■ Detailed configuration of the communication interface ■ Error diagnostics in difficult cases | Contains all the parameters of the device and makes it possible to access these parameters directly using an access code. The structure of this menu is based on the function blocks of the device: <ul style="list-style-type: none"> ■ "System" submenu Contains all higher-order device parameters that do not pertain either to measurement or the measured value communication. ■ "Sensor" submenu Contains all parameters for configuring the measurement. ■ "Output" submenu Contains all parameters for configuring the analog current outputs. ■ "Communication" submenu Contains all parameters for configuring the digital communication interface. ■ "Application" submenu Contains all parameters for configuring the functions that go beyond the actual measurement (e.g. totalizer). ■ "Diagnostics" submenu Contains all parameters for error detection and analyzing process and device errors and for device simulation. |

8.3 Access to the operating menu via the local display

8.3.1 Operational display

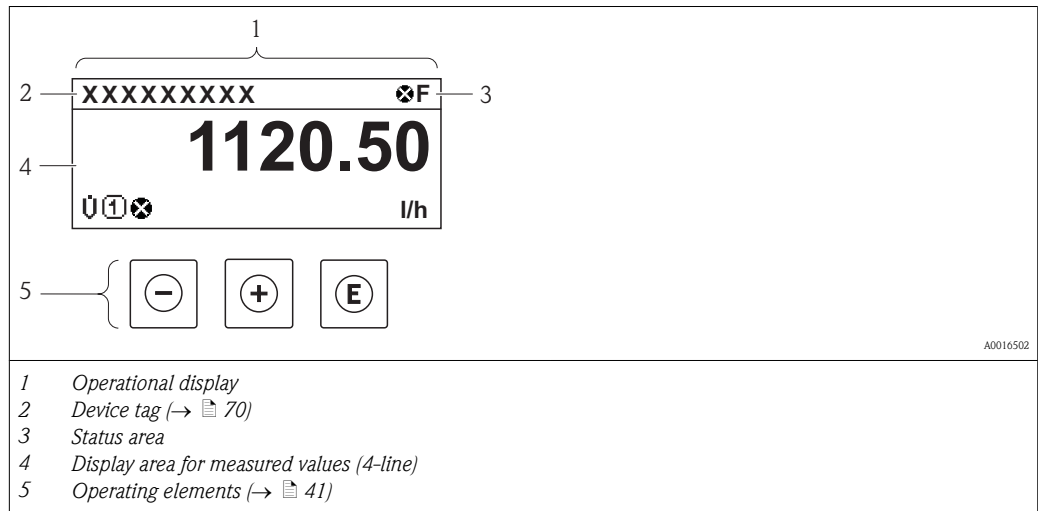

Status area

The following symbols appear in the status area of the operational display at the top right:

- Status signals(→ 89)
- Diagnostic behavior(→ 90)
- Locking
- Communication

Locking

| Symbol | Meaning |
|--|---|
|  <small>A0013963</small> | Device locked The measuring device is hardware locked (→ 78). |

Communication

| Symbol | Meaning |
|--|---|
|  <small>A0013965</small> | Communication via remote operation is active. |

Display area



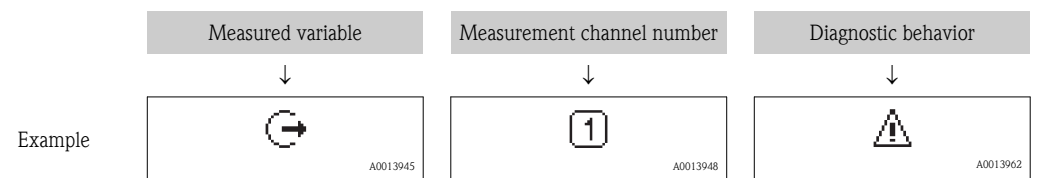



In the display area, each measured value is prefaced by certain symbol types for further description:



Appears only if a diagnostics event is present for this measured variable.

Measured variables

| Symbol | Meaning |
|--------|---------|
|--------|---------|

| | |
|--|---|
|  <small>A0013711</small> | Volume flow |
|  <small>A0017269</small> | Conductivity |
|  <small>A0013710</small> | Mass flow |
|  <small>A0013943</small> | Totalizer  The measurement channel number indicates which of the three totalizers is displayed. |
|  <small>A0013945</small> | Output  The measurement channel number indicates which of the two current outputs is displayed. |

Measurement channel numbers

| Symbol | Meaning |
|--|----------------------------|
|  <small>A0016325</small> | Measurement channel 1 to 4 |

The measurement channel number is displayed only if more than one channel is present for the same measured variable type (e.g. Totalizer 1 to 3).

Diagnostic behavior

The diagnostic behavior pertains to a diagnostic event that is relevant to the displayed measured variable. For information on the symbols (→ 90)

 The number and display of the measured values can be configured via the parameter **Format display** (→ 63). Navigation path: Display/operat. → Display → Format display

8.3.2 Navigation view

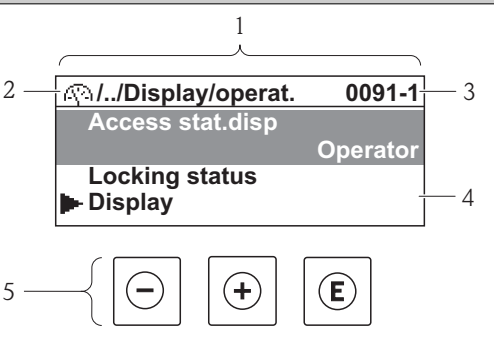
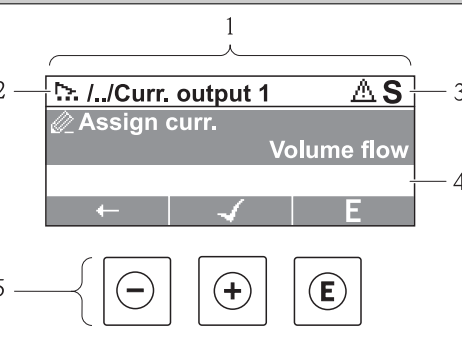
| In the submenu | In the wizard |
|--|---|
|  |  |
| <p>1 Navigation view 2 Navigation path to current position 3 Status area 4 Display area for navigation 5 Operating elements (→ 41)</p> | <p style="text-align: right;"><small>A0013993-EN</small></p> <p style="text-align: right;"><small>A0016327-EN</small></p> |

Navigation path

The navigation path - displayed at the top left in the navigation view - consists of the following elements:

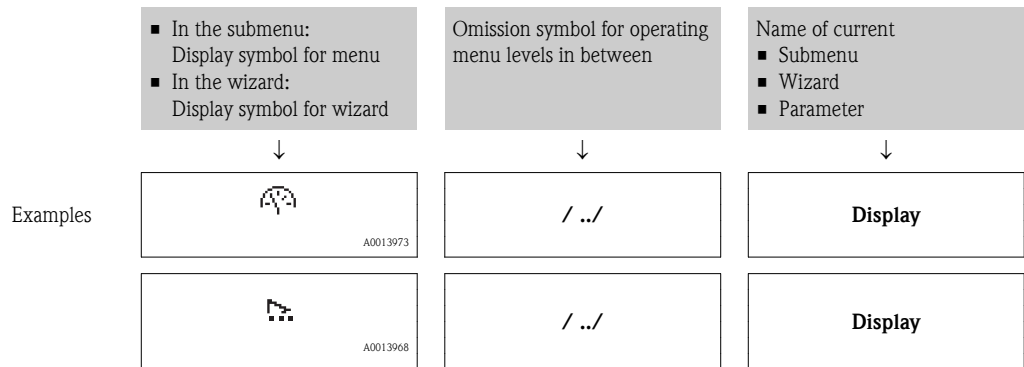



 For more information about the menu icons, refer to the "Display area" section (→  38)

Status area





The following appears in the status area of the navigation view in the top right corner:

- Of the submenu
 - The direct access code for the parameter you are navigating to (e.g. 0022-1)
 - If a diagnostic event is present, the diagnostic behavior and status signal
- In the wizard
 - If a diagnostic event is present, the diagnostic behavior and status signal

-  For information on the diagnostic behavior and status signal (→  89)
- For information on the function and entry of the direct access code (→  43)



Display area

Menus



| Symbol | Meaning |
|--|--|
|  <small>A0013973</small> | Display/operat. Appears: <ul style="list-style-type: none"> In the menu next to the "Display/operat." selection At the left in the navigation path in the "Display/operat." menu |
|  <small>A0013974</small> | Setup Appears: <ul style="list-style-type: none"> In the menu next to the "Setup" selection At the left in the navigation path in the "Setup" menu |
|  <small>A0013975</small> | Diagnostics Appears: <ul style="list-style-type: none"> In the menu next to the "Diagnostics" selection At the left in the navigation path in the "Diagnostics" menu |
|  <small>A0013966</small> | Expert Appears: <ul style="list-style-type: none"> In the menu next to the "Expert" selection At the left in the navigation path in the "Expert" menu |

Submenus, wizards, parameters



| Symbol | Meaning |
|--|---------|
|  <small>A0013967</small> | Submenu |

| | |
|---|--|
|  A0013968 | Wizard |
|  A0013972 | Parameters within a wizard  No display symbol exists for parameters in submenus. |



Locking

| Symbol | Meaning |
|---|---|
|  A0013963 | Parameter locked When displayed in front of a parameter name, indicates that the parameter is locked. <ul style="list-style-type: none"> By a user-specific access code (→  77) By the hardware write protection switch (→  78) |

Wizard operation

| Symbol | Meaning |
|---|--|
|  A0013978 | Switches to the previous parameter. |
|  A0013976 | Confirms the parameter value and switches to the next parameter. |
|  A0013977 | Opens the editing view of the parameter. |

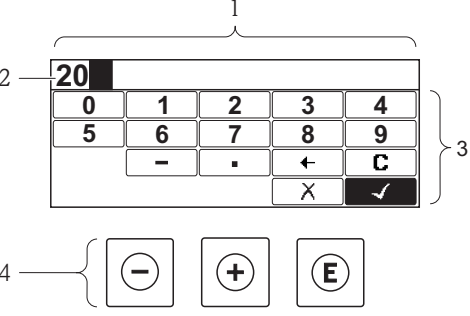
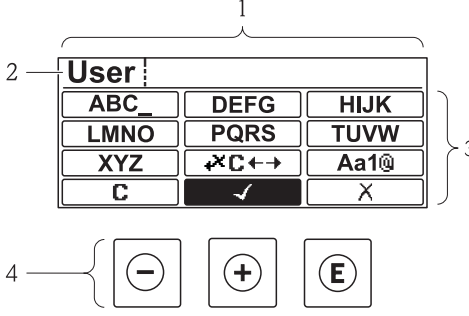

8.3.3 Editing view



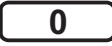
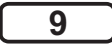

| Numeric editor | Text editor |
|--|---|
|  <p>A0013941</p> |  <p>A0013999</p> |
| <p>1 Editing view 2 Display area of the entered values 3 Input mask 4 Operating elements (→  41)</p> | |

Input mask







The following input symbols are available in the input mask of the numeric and text editor:





Numeric editor symbols

| Symbol | Meaning |
|---|--|
|  ...  A0013998 | Selection of numbers from 0 to 9. |
|  A0016619 | Inserts decimal separator at the input position. |







| | |
|---|--|
|  A0016620 | Inserts minus sign at the input position. |
|  A0013985 | Confirms selection. |
|  A0016621 | Moves the input position one position to the left. |
|  A0013986 | Exits the input without applying the changes. |
|  A0014040 | Clears all entered characters. |

Text editor symbols

| Symbol | Meaning |
|---|---|
|  ...  A0013997 | Selection of letters from A to Z |
|  A0013981 | Toggle <ul style="list-style-type: none"> ■ Between upper-case and lower-case letters ■ For entering numbers ■ For entering special characters |
|  A0013985 | Confirms selection. |
|  A0013987 | Switches to the selection of the correction tools. |
|  A0013986 | Exits the input without applying the changes. |
|  A0014040 | Clears all entered characters. |

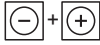
| Correction symbols under  | |
|--|--|
|  A0013989 | Clears all entered characters. |
|  A0013991 | Moves the input position one position to the right. |
|  A0013990 | Moves the input position one position to the left. |
|  A0013988 | Deletes one character immediately to the left of the input position. |

8.3.4 Operating elements

| Key | Meaning |
|--|---|
|  <small>A0013969</small> | <p>Minus key</p> <p><i>In a menu, submenu</i> Moves the selection bar upwards in a choose list.</p> <p><i>With a Wizard</i> Confirms the parameter value and goes to the previous parameter.</p> <p><i>With a text and numeric editor</i> In the input mask, moves the selection bar to the left (backwards).</p> |
|  <small>A0013970</small> | <p>Plus key</p> <p><i>In a menu, submenu</i> Moves the selection bar downwards in a choose list.</p> <p><i>With a Wizard</i> Confirms the parameter value and goes to the next parameter.</p> <p><i>With a text and numeric editor</i> Moves the selection bar to the right (forwards) in an input screen.</p> |
|  <small>A0013952</small> | <p>Enter key</p> <p><i>For operational display</i></p> <ul style="list-style-type: none"> ■ Pressing the key briefly opens the operating menu. ■ Pressing the key for 2 s opens the context menu. <p><i>In a menu, submenu</i></p> <ul style="list-style-type: none"> ■ Pressing the key briefly: <ul style="list-style-type: none"> – Opens the selected menu, submenu or parameter. – Starts the wizard. – If help text is open, closes the help text of the parameter. ■ Pressing the key for 2 s for parameter: <ul style="list-style-type: none"> – If present, opens the help text for the function of the parameter. <p><i>With a Wizard</i> Opens the editing view of the parameter.</p> <p><i>With a text and numeric editor</i></p> <ul style="list-style-type: none"> ■ Pressing the key briefly: <ul style="list-style-type: none"> – Opens the selected group. – Carries out the selected action. ■ Pressing the key for 2 s confirms the edited parameter value. |
|  <small>A0013971</small> | <p>Escape key combination (press keys simultaneously)</p> <p><i>In a menu, submenu</i></p> <ul style="list-style-type: none"> ■ Pressing the key briefly: <ul style="list-style-type: none"> – Exits the current menu level and takes you to the next higher level. – If help text is open, closes the help text of the parameter. ■ Pressing the key for 2 s returns you to the operational display ("home position"). <p><i>With a Wizard</i> Exits the wizard and takes you to the next higher level.</p> <p><i>With a text and numeric editor</i> Closes the text or numeric editor without applying changes.</p> |
|  <small>A0013953</small> | <p>Minus/Enter key combination (press the keys simultaneously)</p> <p>Reduces the contrast (brighter setting).</p> |
|  <small>A0013954</small> | <p>Plus/Enter key combination (press and hold down the keys simultaneously)</p> <p>Increases the contrast (darker setting).</p> |
|  <small>A0013955</small> | <p>Minus/Plus/Enter key combination (press the keys simultaneously)</p> <p><i>For operational display</i> Enables or disables the keypad lock.</p> |

8.3.5 Opening the context menu

Using the context menu, the user can call up the following menus quickly and directly from the operational display:

- Setup
- Conf. backup disp.
- Simulation

Calling up and closing the context menu

The user is in the operational display.

1. Press **⏏** for 2 s.
 - ✓ The context menu opens.

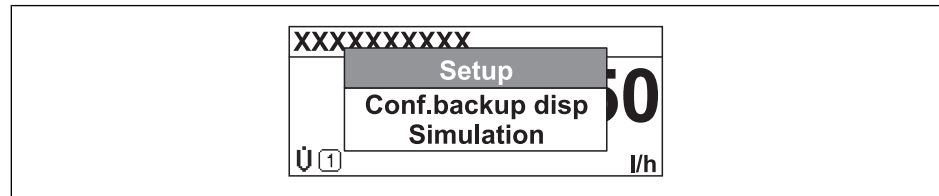

A0016326-EN



2. Press **←** + **→** simultaneously.
 - ✓ The context menu is closed and the operational display appears.

Calling up the menu via the context menu

1. Open the context menu.
2. Press **→** to navigate to the desired menu.
3. Press **⏏** to confirm the selection.
 - ✓ The selected menu opens.

8.3.6 Navigating and selecting from list

Different operating elements are used to navigate through the operating menu. The navigation path is displayed on the left in the header. Icons are displayed in front of the individual menus. These icons are also shown in the header during navigation.

 For an explanation of the navigation view with symbols and operating elements (→  37)

Example: Setting the number of displayed measured values to "2 values"

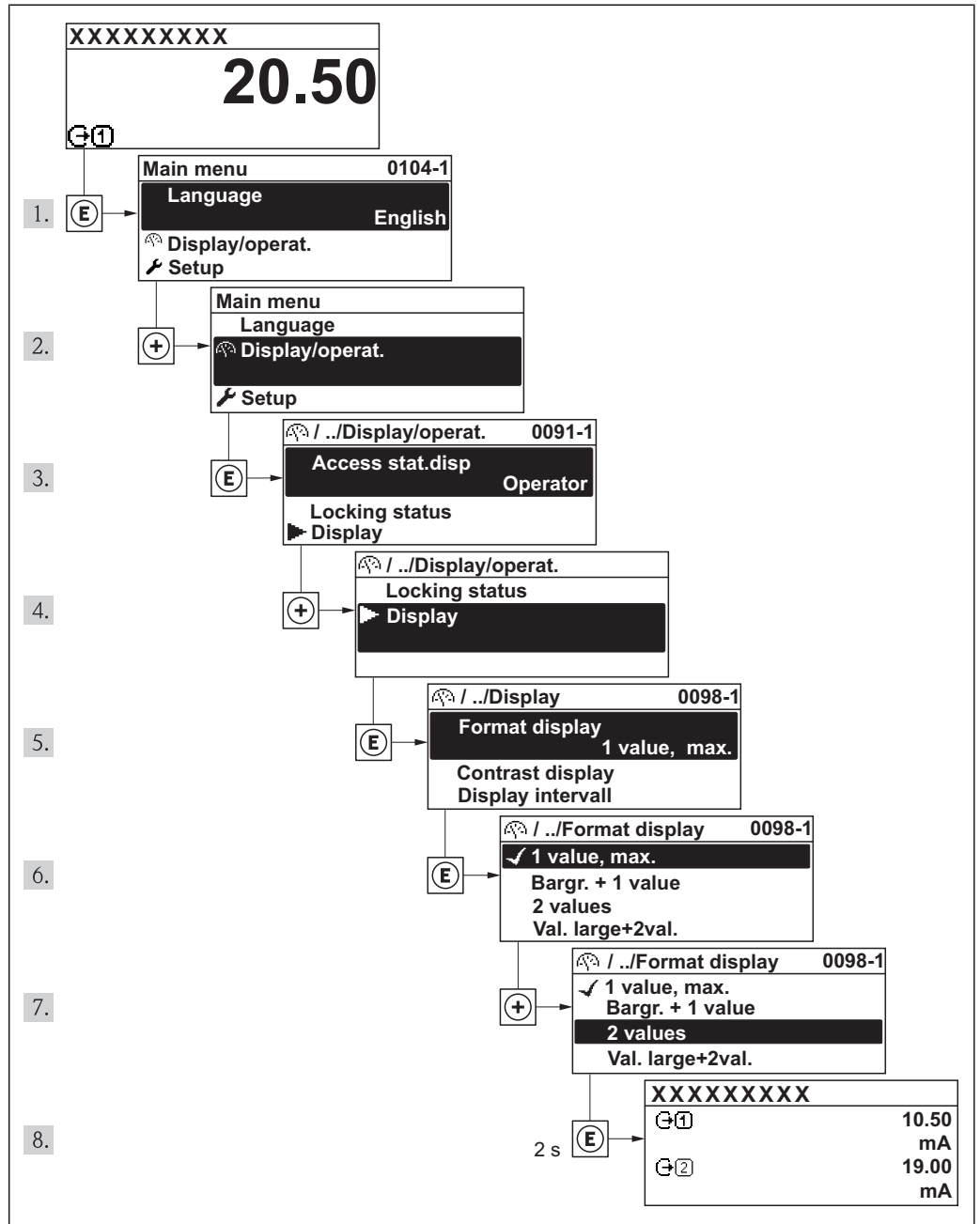

A0014010-EN

8.3.7 Calling the parameter directly

A parameter number is assigned to every parameter to be able to access a parameter directly via the onsite display. Entering this access code in the **Direct access** parameter calls up the desired parameter directly.

Navigation path

"Expert" menu → Direct access

The direct access code consists of a 4-digit number and the channel number, which identifies the channel of a process variable: e.g. 0914-1. In the navigation view, this appears on the right-hand side in the header of the selected parameter.

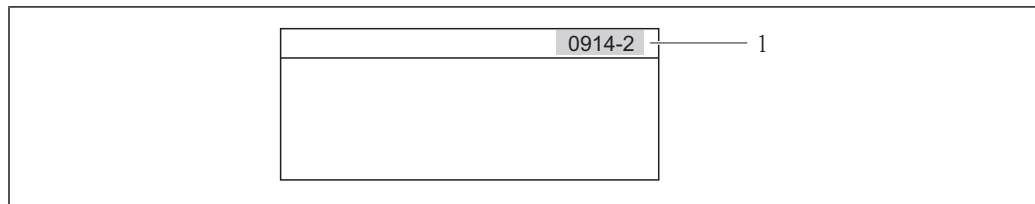

A0017223

1 Direct access code

Note the following when entering the direct access code:

- The leading zeros in the direct access code do not have to be entered.
Example: Input of "914" instead of "0914"
- If no channel number is entered, channel 1 is jumped to automatically.
Example: Input of "0914" → Parameter **Totalizer 1**
- If a different channel is jumped to: Enter the direct access code with the corresponding channel number.
Example: Input of "0914-2" → Parameter **Totalizer 2**

 For the direct access codes of the individual parameters

8.3.8 Calling up help text

For some parameters, help texts exist, which the user can call up from the navigation view. These briefly describe the function of the parameter and thus support fast and reliable commissioning.

Calling up and closing the help text

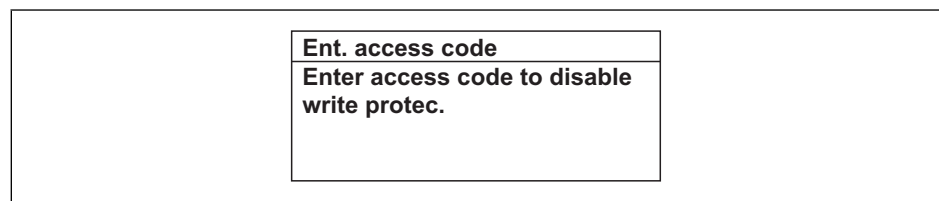

The user is in the navigation view and the selection bar is on a parameter.

1. Press  for 2 s.
 - ✓ The help text for the selected parameter opens.



A0014002-EN

 12 Example: Help text for parameter "Enter access code"

2. Press  +  simultaneously.
 - ✓ The help text is closed.

8.3.9 Changing the parameters

i For a description of the editing display - consisting of text editor and numeric editor - with symbols (→ 39), for a description of the operating elements (→ 41)

Example: Changing the parameter "20 mA value" to 20 l/h

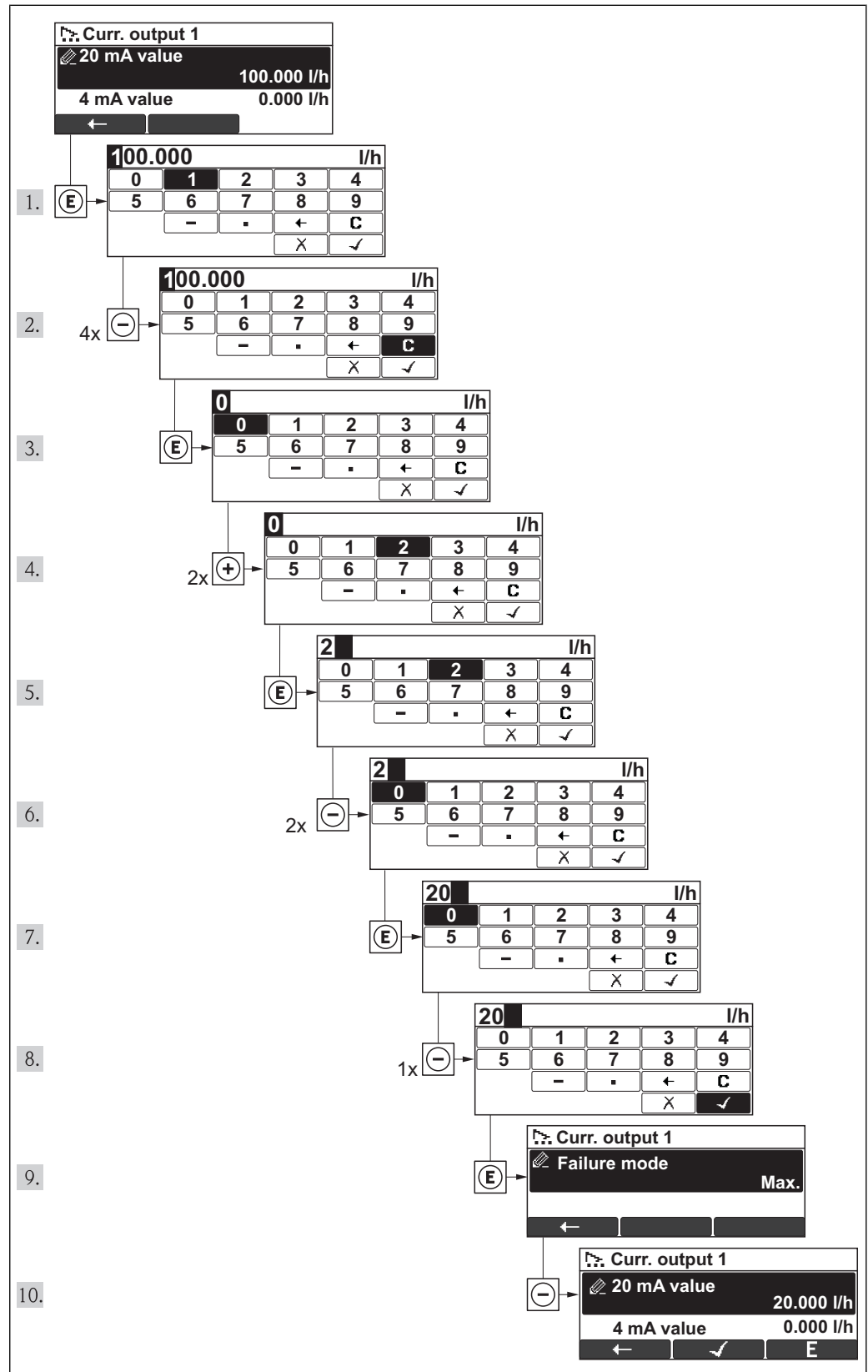

A0016332-EN

A message is displayed if the value entered is outside the permitted value range.

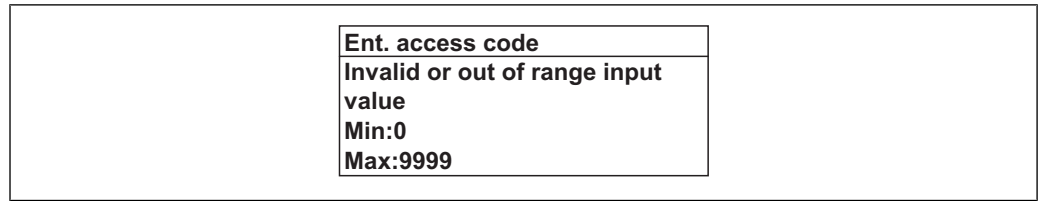

A0014049-EN

8.3.10 User roles and related access authorization

The two user roles "Operator" and "Maintenance" have different write access to the parameters if the customer defines a user-specific access code. This protects the device configuration via the local display from unauthorized access (→ 77).

Access authorization to parameters

| User role | Read access | | Write access | |
|-------------|--|------------------|--|------------------|
| | Without access code (from the factory) | With access code | Without access code (from the factory) | With access code |
| Operator | ✓ | ✓ | ✓ | – 1) |
| Maintenance | ✓ | ✓ | ✓ | ✓ |

1) Despite the defined access code, certain parameters can always be modified and thus are excepted from the write protection, as they do not affect the measurement. Refer to the "Write protection via access code" section

If an incorrect access code is entered, the user obtains the access rights of the "Operator" role.

i The user role with which the user is currently logged on is indicated by the **Access status display** parameter. Navigation path: Display/operation → Access status display

8.3.11 Disabling write protection via access code

If the -symbol appears on the local display in front of a parameter, the parameter is write-protected by a user-specific access code and its value cannot be changed at the moment using the local display (→ 77).

The locking of the write access via local operation can be disabled by entering the customer-defined access code via the respective access option.

1. After you press , the input prompt for the access code appears.
2. Enter the access code.
 - ✓ The -symbol in front of the parameters disappears; all previously write-protected parameters are now re-enabled.

8.3.12 Enabling and disabling the keypad lock

The keypad lock makes it possible to block access to the entire operating menu via local operation. As a result, it is no longer possible to navigate through the operating menu or change the values of individual parameters. Users can only read the measured values on the operational display.

The keypad lock is enabled and disabled in the same way:

The user is in the operational display.

- ▶ By simultaneously pressing the + + keys.
 - ✓ After enabling the keypad lock:

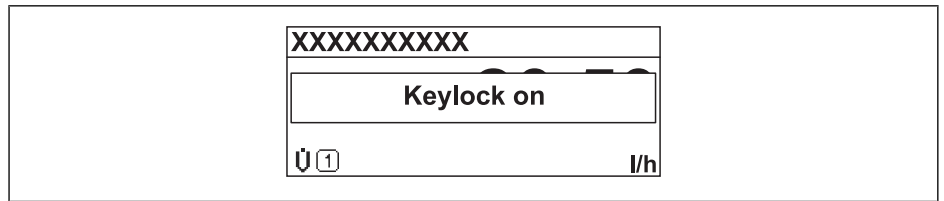

A0016215-EN

After disabling the keypad lock:

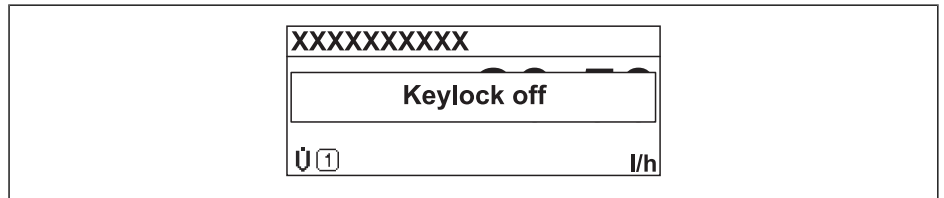

A0016216-EN

 If the user attempts to access the operating menu while the keylock is enabled, the message **Keylock on** also appears.

8.4 Access to the operating menu via the operating tool

The structure of the operating menu in the operating tools is the same as for operation via the local display.

8.4.1 Connecting the operating tool

Via HART protocol

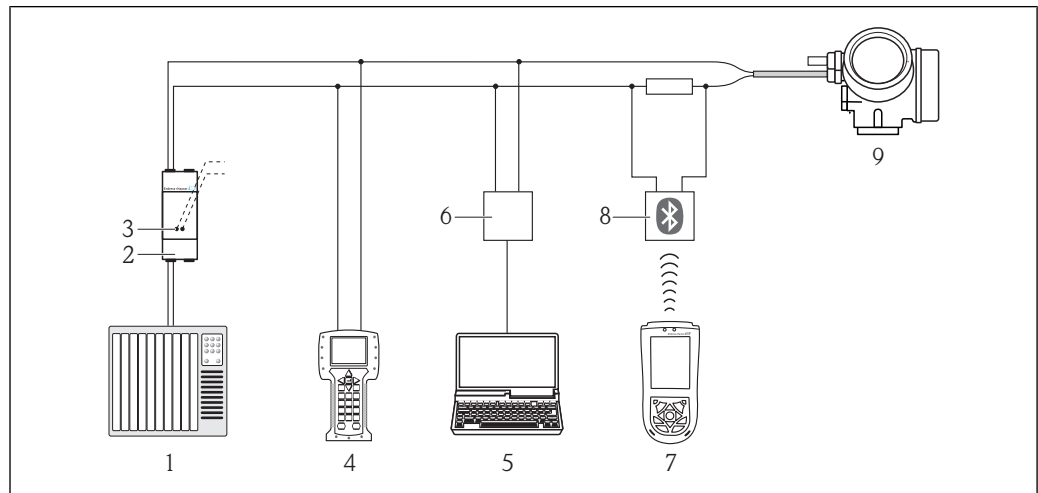

A0013764

13 Options for remote operation via HART protocol

- 1 Control system (e.g. PLC)
- 2 Transmitter power supply unit, e.g. RN221N (with communication resistor)
- 3 Connection for Commubox FXA195 and Field Communicator 475
- 4 Field Communicator 475
- 5 Computer with operating tool (e.g. FieldCare, AMS Device Manager, SIMATIC PDM)
- 6 Commubox FXA195 (USB)
- 7 Field Xpert SFX100
- 8 VIATOR Bluetooth modem with connecting cable
- 9 Transmitter

Via service interface (CDI)

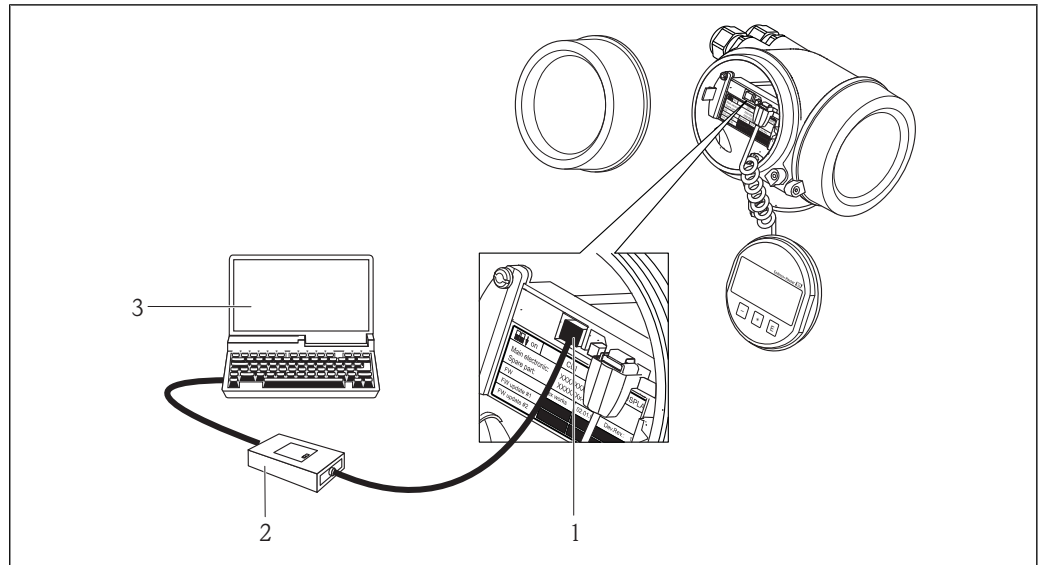

- 1 Service interface (CDI = Endress+Hauser Common Data Interface) of the measuring device
 2 Commubox FXA291
 3 Computer with "FieldCare" operating tool with COM DTM "CDI Communication FXA291"

A0014019

8.4.2 Field Xpert SFX100

Function scope

Compact, flexible and robust industrial handheld terminal for remote configuration and measured value display via HART protocol.

 For details, see Operating Instructions BA00060S

Source for device description files



See data (→  51)

8.4.3 FieldCare

Function scope

FDT-based plant asset management tool from Endress+Hauser. It can configure all smart field devices in a system and helps you manage them. By using the status information, it is also a simple but effective way of checking their status and condition.

Access takes place via:

- HART protocol (→  48)
- Service interface CDI (→  49)

Typical functions:

- Configuring parameters of transmitters
- Loading and saving device data (upload/download)
- Documentation of the measuring point
- Visualization of the measured value memory (line recorder) and event logbook

 For details, see Operating Instructions BA00027S and BA00059S

Source for device description files

See data (→  51)

User interface**8.4.4 AMS Device Manager****Function scope**

Program from Emerson Process Management for operating and configuring measuring devices via HART protocol.

Source for device description files

See data (→  51)

8.4.5 SIMATIC PDM**Function scope**

SIMATIC PDM is a standardized, manufacturer-independent program from Siemens for the operation, configuration, maintenance and diagnosis of intelligent field devices via HART protocol.

Source for device description files

See data (→  51)

8.4.6 Field Communicator 475**Function scope**

Industrial handheld terminal from Emerson Process Management for remote configuration and measured value display via HART protocol.

Source for device description files

See data (→  51)

9 System integration

9.1 Overview of device description files

9.1.1 Current version data for the device

| | | |
|----------------------------------|----------|---|
| Firmware version | 01.00.zz | <ul style="list-style-type: none"> ■ On the title page of the Operating instructions ■ On transmitter nameplate(→ 12) ■ Parameter firmware version Diagnostics → Device info → Firmware version |
| Release date of firmware version | 07.2012 | — |
| Manufacturer ID | 0x11 | Manufacturer ID parameter Diagnostics → Device info → Manufacturer ID |
| Device type ID | 0x48 | Device type parameter Diagnostics → Device info → Device type |
| HART protocol revision | 6.0 | — |
| Device revision | 1 | <ul style="list-style-type: none"> ■ On transmitter nameplate(→ 12) ■ Device revision parameter Diagnostics → Device info → Device revision |

9.1.2 Operating tools

The following is a list of the suitable device description file for each individual operating tool with source.

| Operating tool via HART protocol | Sources for obtaining device descriptions |
|--|---|
| Field Xpert SFX100 | Use update function of handheld terminal |
| FieldCare | <ul style="list-style-type: none"> ■ www.endress.com → Download Area ■ CD-ROM (contact Endress+Hauser) ■ DVD (contact Endress+Hauser) |
| AMS Device Manager (Emerson Process Management) | www.endress.com → Download Area |
| SIMATIC PDM (Siemens) | www.endress.com → Download Area |
| Field Communicator 475 (Emerson Process Management) | Use update function of handheld terminal |

9.2 Measured variables via HART protocol

The following measured variables (HART device variables) are assigned to the dynamic variables at the factory:

| Dynamic variables | Measured variables (HART device variables) |
|----------------------------------|---|
| Primary dynamic variable (PV) | Volume flow |
| Secondary dynamic variable (SV) | Totalizer 1 |
| Tertiary dynamic variable (TV) | Totalizer 2 |
| Quaternary dynamic variable (QV) | Totalizer 3 |

The assignment of the measured variables to the dynamic variables can be modified and assigned as desired via local operation and the operating tool using the following parameters:

- Expert → Communication → HART output → Output → Assign PV
- Expert → Communication → HART output → Output → Assign SV
- Expert → Communication → HART output → Output → Assign TV
- Expert → Communication → HART output → Output → Assign QV

The following measured variables can be assigned to the dynamic variables:

Measured variables for PV (primary dynamic variable)

- Volume flow
- Mass flow

Measured variables for SV, TV, QV (secondary, tertiary and quaternary dynamic variable)

- Volume flow
- Mass flow
- Totalizer 1
- Totalizer 2
- Totalizer 3

9.3 Other settings

In the **Configuration** submenu, you can configure other settings for the HART protocol (e.g. Burst mode)

Navigation path

"Expert" menu → Communication → HART output → Configuration

10 Commissioning

10.1 Function check

Before commissioning the device, make sure that the post-installation and post-connection checks have been performed.

- "Post-mounting check" checklist (→ 25)
- "Post-connection check" checklist (→ 32)

10.2 Switching on the measuring device

After a successful function check, switch on the measuring device.

After a successful startup, the local display switches automatically from the startup display to the operational display.

i If nothing appears on the local display or a diagnostic message is displayed, refer to the section on "Diagnostics and troubleshooting" (→ 87).

10.3 Setting the operating language

Factory setting: English or ordered local language

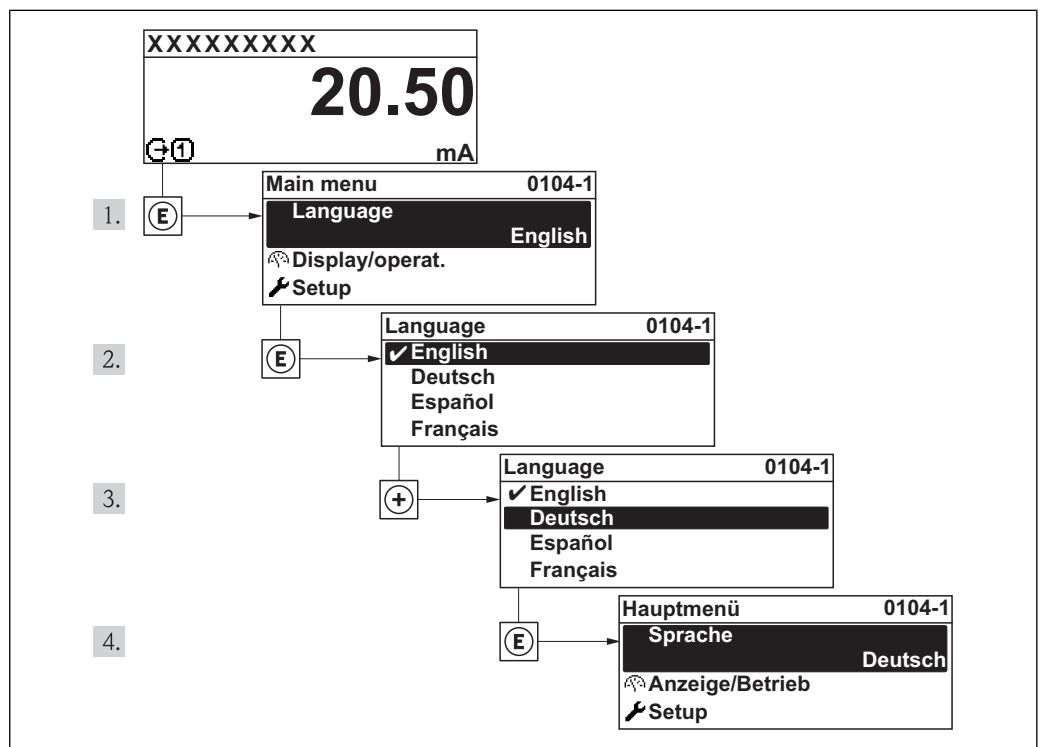

14 Illustrated using the example of the local display

A0013996

10.4 Configuring the measuring device

The **Setup** menu with its guided wizards contains all parameters needed for standard operation.

Navigation to the "Setup" menu

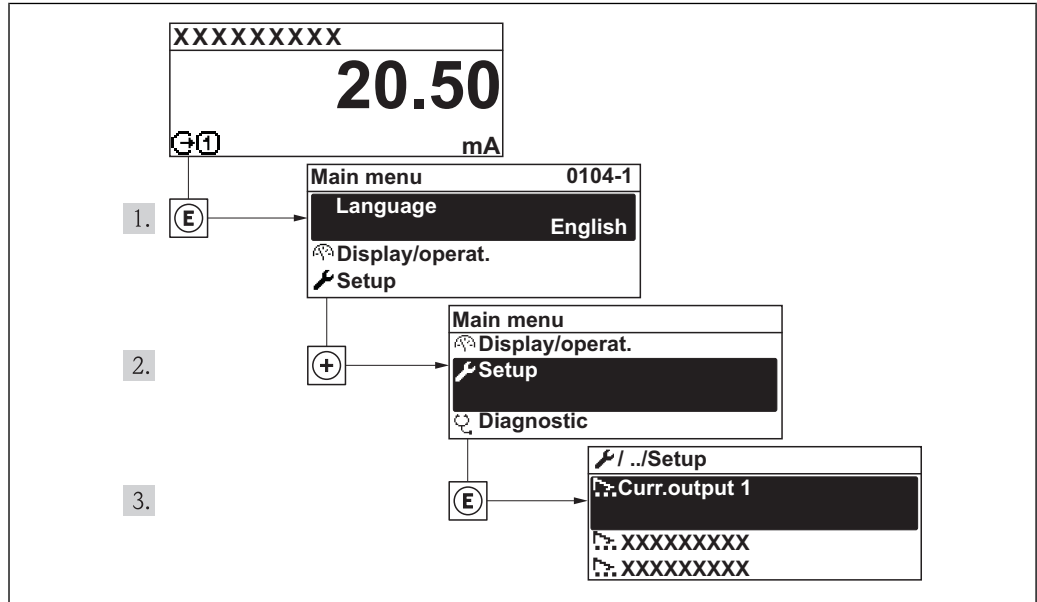

A0018774-EN

15 Illustrated using the example of the local display

Overview of the wizards in the "Setup" menu

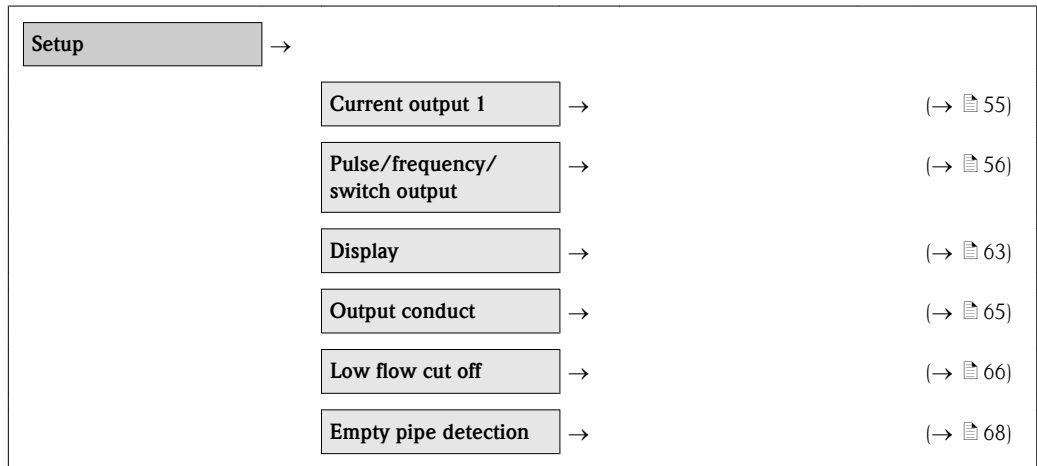

10.4.1 Configuring the current output

The **Current output** wizard guides you systematically through all parameters that have to be set for configuring the current output.

Navigation path

"Setup" menu → Current output

Structure of the wizard

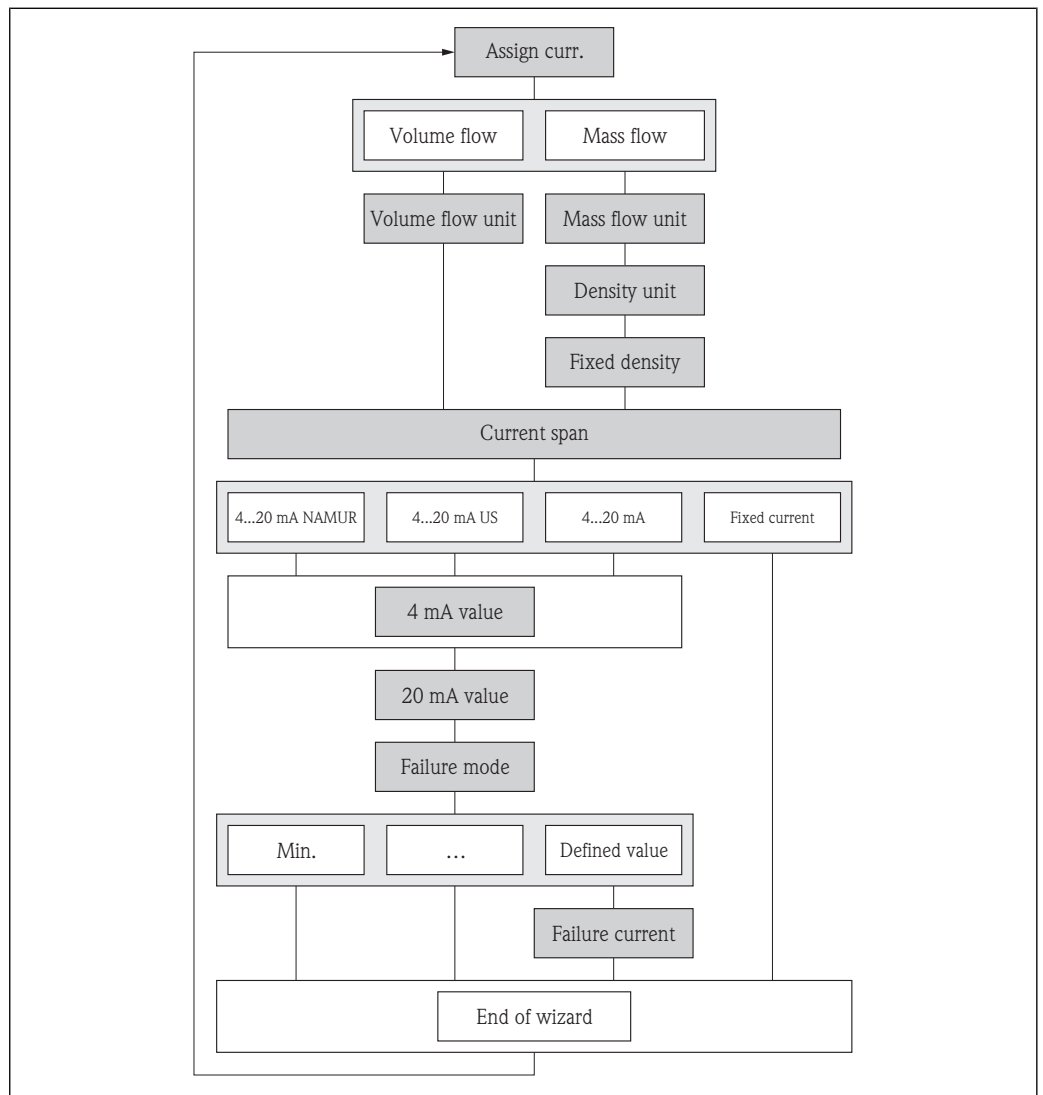

A0018498-EN

16 "Current output" wizard in the "Setup" menu

Parameter overview with brief description

| Parameters | Description | Selection/ User entry | Factory setting |
|-----------------------|---|--|-----------------|
| Assign current output | Select process variable for current output. | <ul style="list-style-type: none"> ■ Volume flow ■ Mass flow | Volume flow |

| | | | |
|------------------|--|---|---|
| Volume flow unit | Select volume flow unit. <i>Result</i> The selected unit applies for: – Outputs – Low flow cutoff – Simulation process variable | Unit choose list | Depends on country and nominal diameter |
| Mass flow unit | Select the unit for mass flow. <i>Result</i> The selected unit applies for: – Outputs – Low flow cutoff – Simulation process variable | Unit choose list | Depends on country and nominal diameter |
| Density unit | Select the unit for density. <i>Result</i> The selected unit applies for: Fixed density | Unit choose list | Country-dependent ■ kg/l ■ g/cc |
| Fixed density | Enter the fixed value for the density. | Max. 15-digit, positive floating-point number | Country-dependent: ■ 1 kg/l ■ 1 g/cc |
| Current span | Select the current range for the process value output and for the upper and lower level for signal on alarm. | ■ 4 to 20 mA NAMUR ■ 4 to 20 mA US ■ 4 to 20 mA ■ Fixed current | Country-dependent: ■ 4 to 20 mA NAMUR ■ 4 to 20 mA US |
| 4 mA value | Enter 4 mA value. | Max. 15-digit floating-point number with sign | Depends on country and nominal diameter |
| 20 mA value | Enter 20 mA value. | Max. 15-digit floating-point number with sign | Depends on country and nominal diameter |
| Failure mode | Select the value the current output adopts in an alarm condition. | ■ Min. ■ Max. ■ Last valid value ■ Actual value ■ Defined value | Max. |
| Failure current | Select the current value the current output adopts in an alarm condition. | 3.59 to 22.5 mA | 22.5 mA |

10.4.2 Configuring the pulse/frequency/switch output

The **Pulse/frequency/switch output** wizard guides you systematically through all parameters that can be set for the configuration of the selected output type.

Navigation path

"Setup" menu → Pulse/frequency/switch output

Structure of the wizard for the pulse output

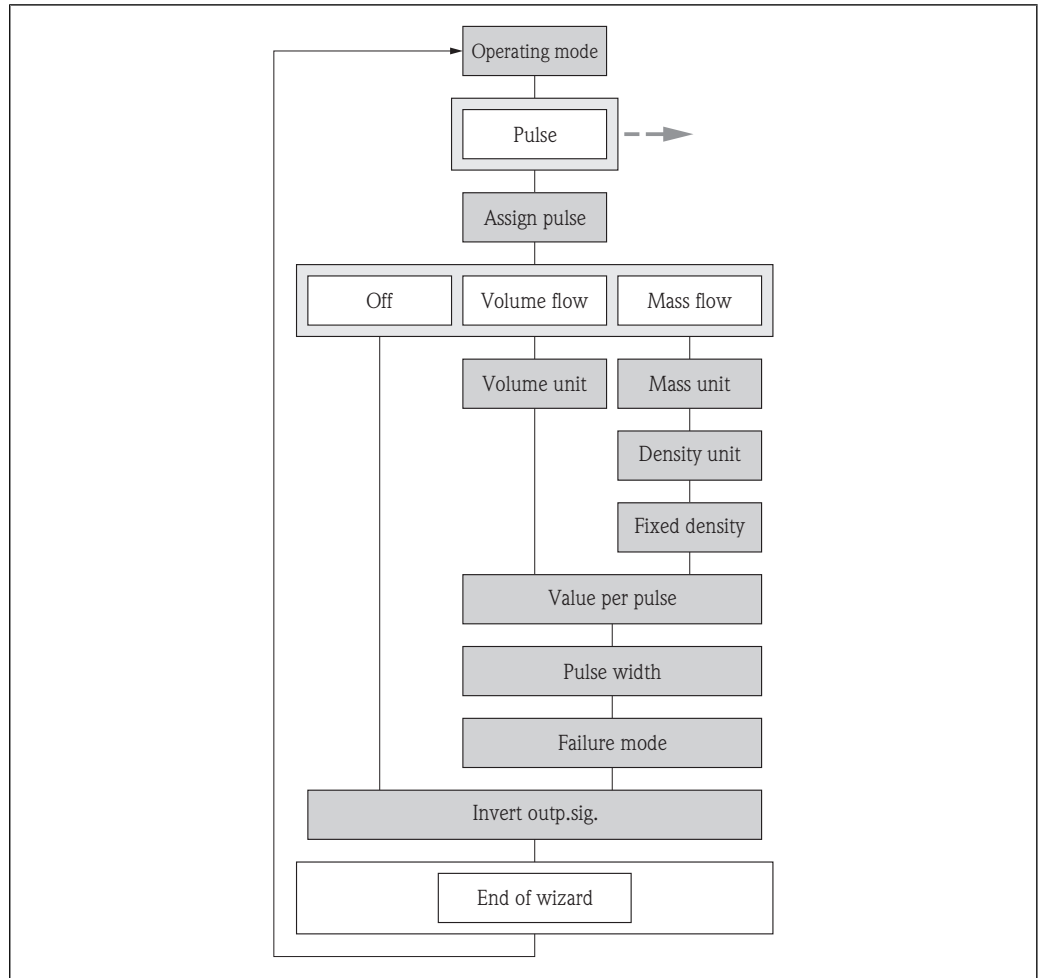

A0018551-EN

17 "Pulse/frequency/switch output" wizard in the "Setup" menu: "Pulse" operating mode

Parameter overview with brief description for pulse output

| Parameter | Description | Selection/ User entry | Factory setting |
|---------------------|--|--|---|
| Operating mode | Specify the output as a pulse, frequency or switch output. | <ul style="list-style-type: none"> ■ Pulse ■ Frequency ■ Switch <p> The picklist depends on the selected device order (→ 27).</p> | Pulse |
| Assign pulse output | Select the process variable for the pulse output. | <ul style="list-style-type: none"> ■ Off ■ Volume flow ■ Mass flow | Off |
| Volume unit | Select the unit for volume. <i>Result</i> The selected unit is taken from: Volume flow unit | Unit choose list | Depends on country and nominal diameter |

| | | | |
|----------------------|--|--|--|
| Mass unit | Select the unit for mass. <i>Result</i> The selected unit is taken from: Mass flow unit | Unit choose list | Depends on country and nominal diameter |
| Density unit | Select the unit for density. <i>Result</i> The selected unit applies for: Fixed density | Unit choose list | Country-dependent ■ kg/l ■ g/cc |
| Fixed density | Enter the fixed value for the density. | Floating-point number | Country-dependent: ■ 1 kg/l ■ 1 g/cc |
| Pulse value | Enter the measured value for the pulse output. | Depends on the process variable selected | Depends on country and nominal diameter |
| Pulse width | Specify the duration of the output pulse. <i>Result</i> The selected pulse width also applies for: Fixed simulation value of the pulse output | 5 to 2000 ms | 100 ms |
| Failure mode | Specify the output behavior in the event of a device alarm. | ■ Actual value ■ No pulses | No pulses |
| Invert output signal | Invert the output signal. | ■ No ■ Yes | No |

Structure of the wizard for the frequency output

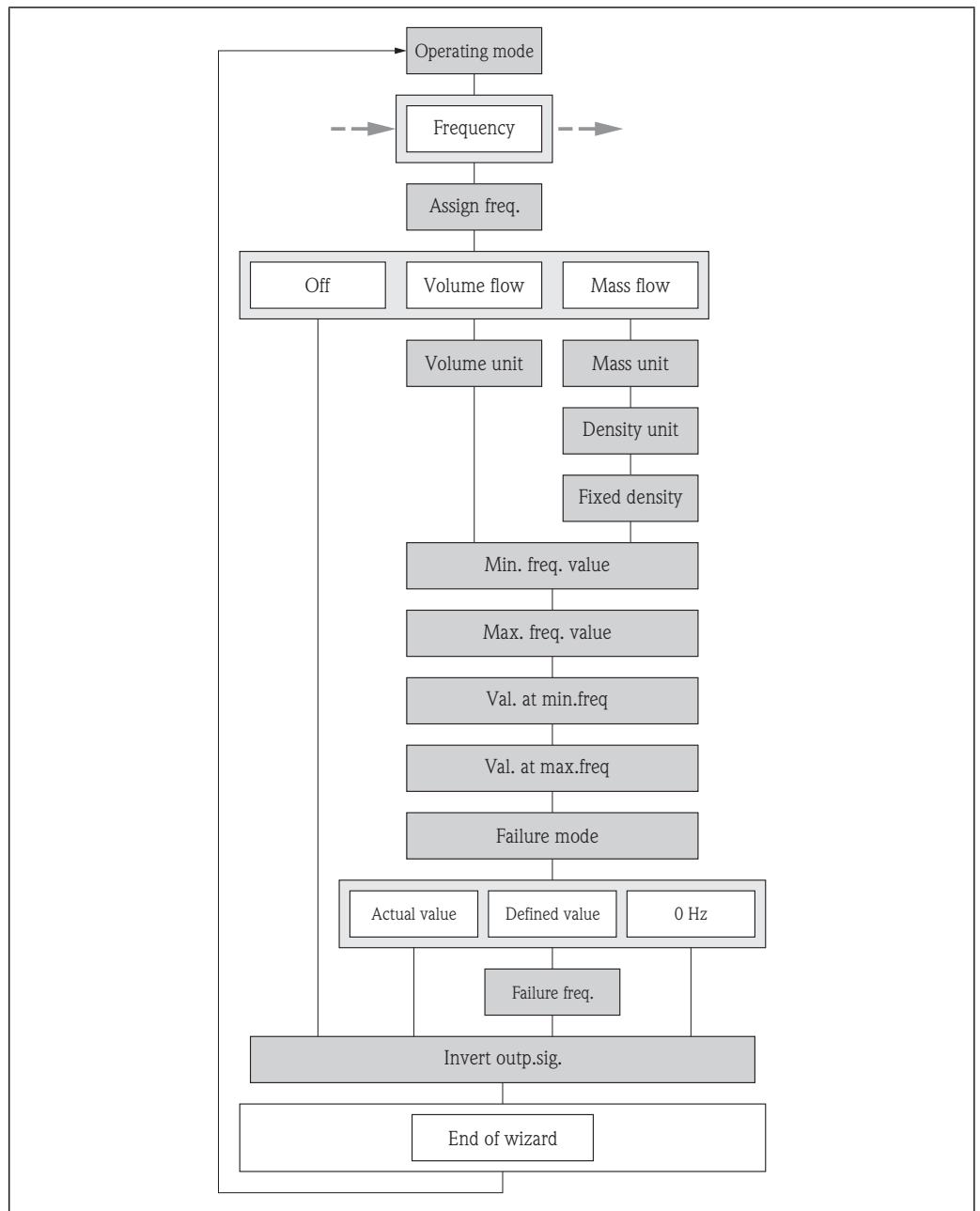

A0018557-EN

18 "Pulse/frequency/switch output " wizard in the "Setup" menu: "Frequency" operating mode

Parameter overview with brief description for frequency output

| Parameter | Description | Selection/ User entry | Factory setting |
|-------------------------|--|--|-----------------|
| Operating mode | Specify the output as a pulse, frequency or switch output. | <ul style="list-style-type: none"> ■ Pulse ■ Frequency ■ Switch <p> The picklist depends on the selected device order (→ 27).</p> | Pulse |
| Assign frequency output | Select the process variable for the frequency output. | <ul style="list-style-type: none"> ■ Off ■ Volume flow ■ Mass flow | Off |

| | | | |
|--------------------------------------|---|---|--|
| Volume flow unit | Select the unit for volume flow. <i>Result</i> The selected unit applies for: – Outputs – Low flow cut off – Simulation process variable | Unit choose list | Depends on country and nominal diameter |
| Mass flow unit | Select the unit for mass flow. <i>Result</i> The selected unit applies for: – Outputs – Low flow cut off – Simulation process variable | Unit choose list | Depends on country and nominal diameter |
| Density unit | Select the unit for density. <i>Result</i> The selected unit applies for: Fixed density | Unit choose list | Country-dependent ■ kg/l ■ g/cc |
| Fixed density | Enter the fixed value for the density. | Floating-point number | Country-dependent: ■ 1 kg/l ■ 1 g/cc |
| Minimum frequency value | Enter the minimum frequency value. | 0.0 to 1 000.0 | 0.0 Hz |
| Maximum frequency value | Enter the maximum frequency value. | 0 to 1 000 Hz | 1 000 Hz |
| Measuring value at minimum frequency | Enter the measured value at the minimum frequency. | Depends on the process variable selected | – |
| Measuring value at maximum frequency | Specify the measured value at maximum frequency. | Depends on the process variable selected | – |
| Failure mode | Specify the output behavior in the event of a device alarm. | ■ Actual value ■ Defined value ■ 0 Hz | 0 Hz |
| Failure frequency | Enter the value for the frequency output in the event of a device alarm. | 0.0 to 1 250.0 Hz | 0.0 Hz |
| Invert output signal | Invert the output signal. | ■ No ■ Yes | No |

Structure of the wizard for the switch output

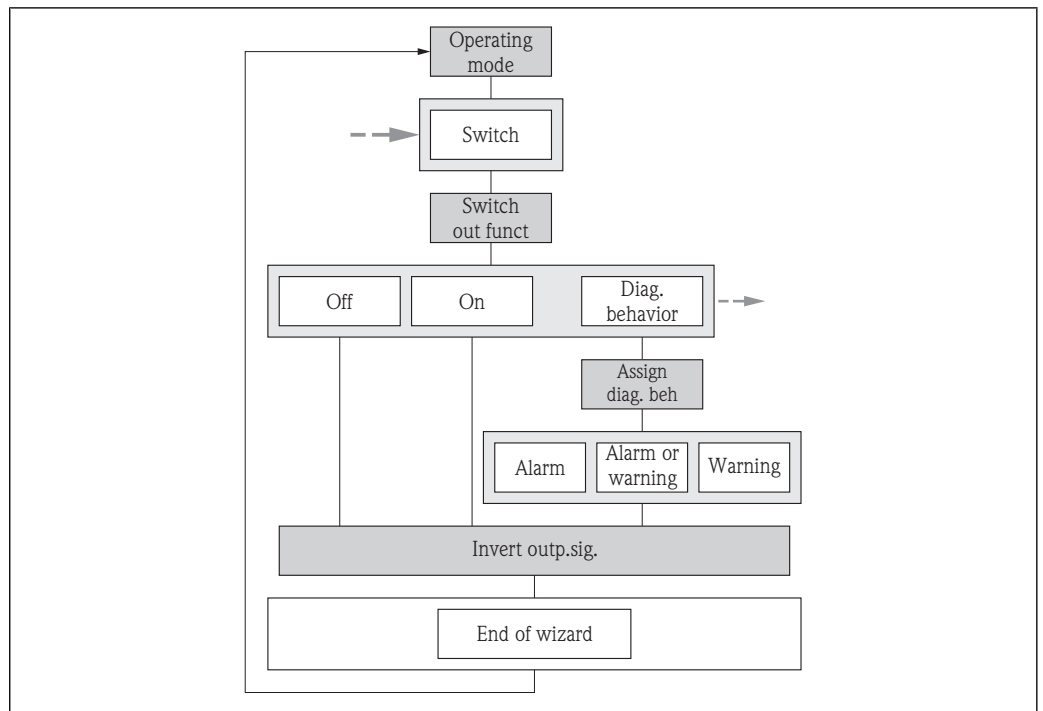

A0018575-EN

19 "Pulse/frequency/switch output " wizard in the "Setup" menu: "Switch" operating mode (Part 1)

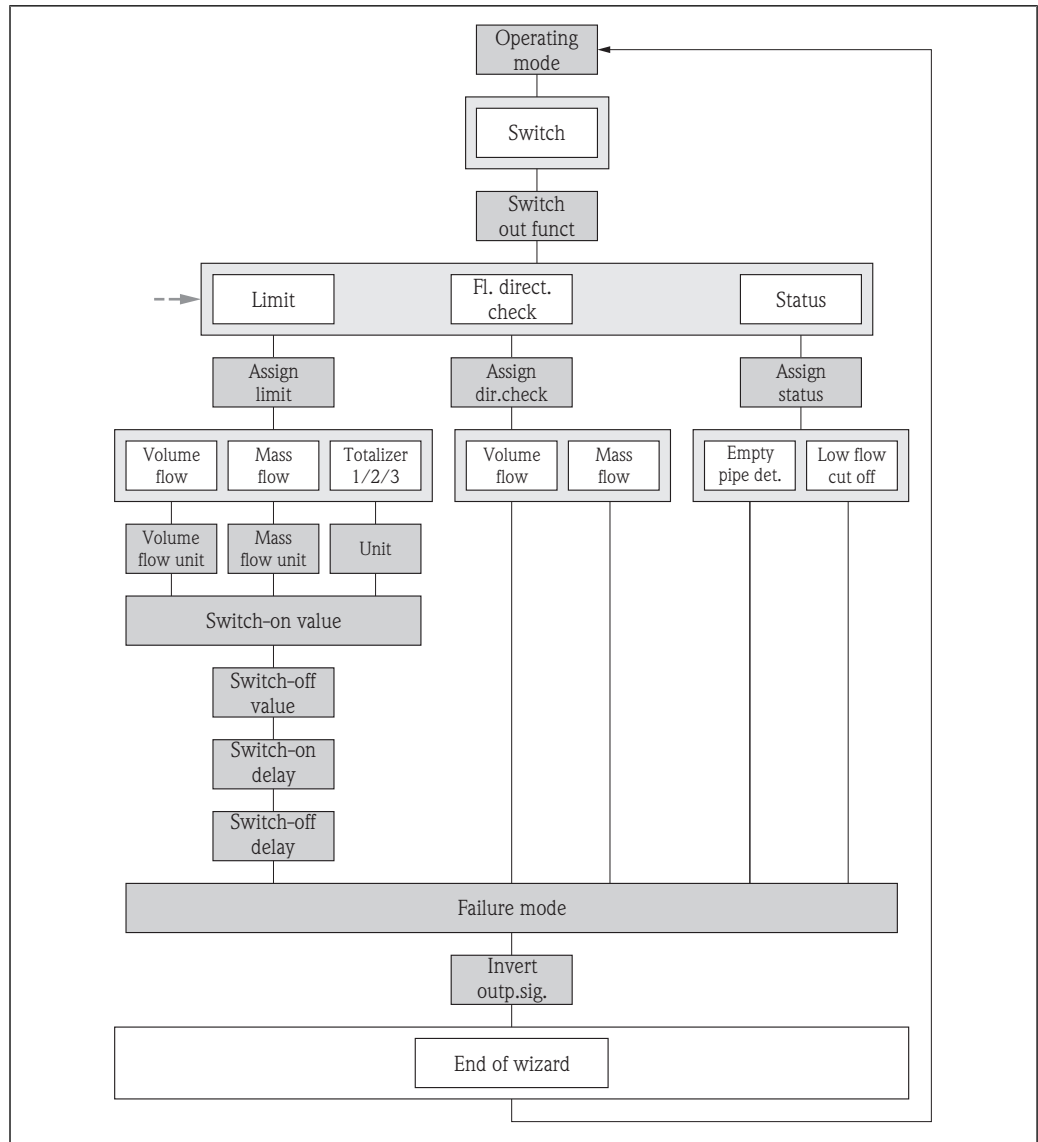

A0018576-EN

20 "Pulse/frequency/switch output" wizard in the "Setup" menu: "Switch" operating mode (Part 2)

Parameter overview with brief description for switch output

| Parameter | Description | Selection/ User entry | Factory setting |
|----------------------------|--|--|-----------------|
| Operating mode | Specify the output as a pulse, frequency or switch output. | <ul style="list-style-type: none"> ■ Pulse ■ Frequency ■ Switch <p> The picklist depends on the selected device order (→ 27).</p> | Pulse |
| Switch output function | Select the function for the switch output. | <ul style="list-style-type: none"> ■ Off ■ On ■ Diagnostic behavior ■ Limit value ■ Flow direction monitoring ■ Status | Off |
| Assign diagnostic behavior | Select the diagnostic behavior for the switch output. | <ul style="list-style-type: none"> ■ Alarm ■ Alarm or warning ■ Warning | Alarm |

| | | | |
|-----------------------------|---|---|---|
| Assign limit | Select the process variable for the limit function. | <ul style="list-style-type: none"> ■ Volume flow ■ Mass flow ■ Totalizer 1 ■ Totalizer 2 ■ Totalizer 3 | Volume flow |
| Assign flow direction check | Select the process variable for monitoring the direction of flow in your process. | <ul style="list-style-type: none"> ■ Volume flow ■ Mass flow | Volume flow |
| Assign status | Select the device status for the switch output. | <ul style="list-style-type: none"> ■ Empty pipe detection ■ Low flow cut off | Empty pipe detection |
| Volume flow unit | Select the unit for volume flow. <i>Result</i> The selected unit applies for: – Outputs – Low flow cut off – Simulation process variable | Unit choose list | Depends on country and nominal diameter |
| Mass flow unit | Select the unit for mass flow. <i>Result</i> The selected unit applies for: – Outputs – Low flow cut off – Simulation process variable | Unit choose list | Depends on country and nominal diameter |
| Unit totalizer | Select the unit for the process variable of the totalizer. | Unit choose list | Depends on country and nominal diameter |
| Switch-on value | Enter the measured value for the switch-on value. | Depends on the process variable selected | - |
| Switch-off value | Enter the measured value for the switch-off value. | Depends on the process variable selected | - |
| Switch-on delay | Specify the delay time for switching on the switch output. | 0.0 to 100.0 s | 0.0 s |
| Switch-off delay | Specify the delay time for switching off the switch output. | 0.0 to 100.0 s | 0.0 s |
| Failure mode | Specify the output behavior in the event of a device alarm. | <ul style="list-style-type: none"> ■ Current status ■ Open ■ Closed | Open |
| Invert output signal | Invert the output signal. | <ul style="list-style-type: none"> ■ No ■ Yes | No |

10.4.3 Configuring the local display

The **Display** wizard guides you systematically through all parameters that can be configured for configuring the local display.

Navigation path

"Setup" menu → Display

Structure of the wizard

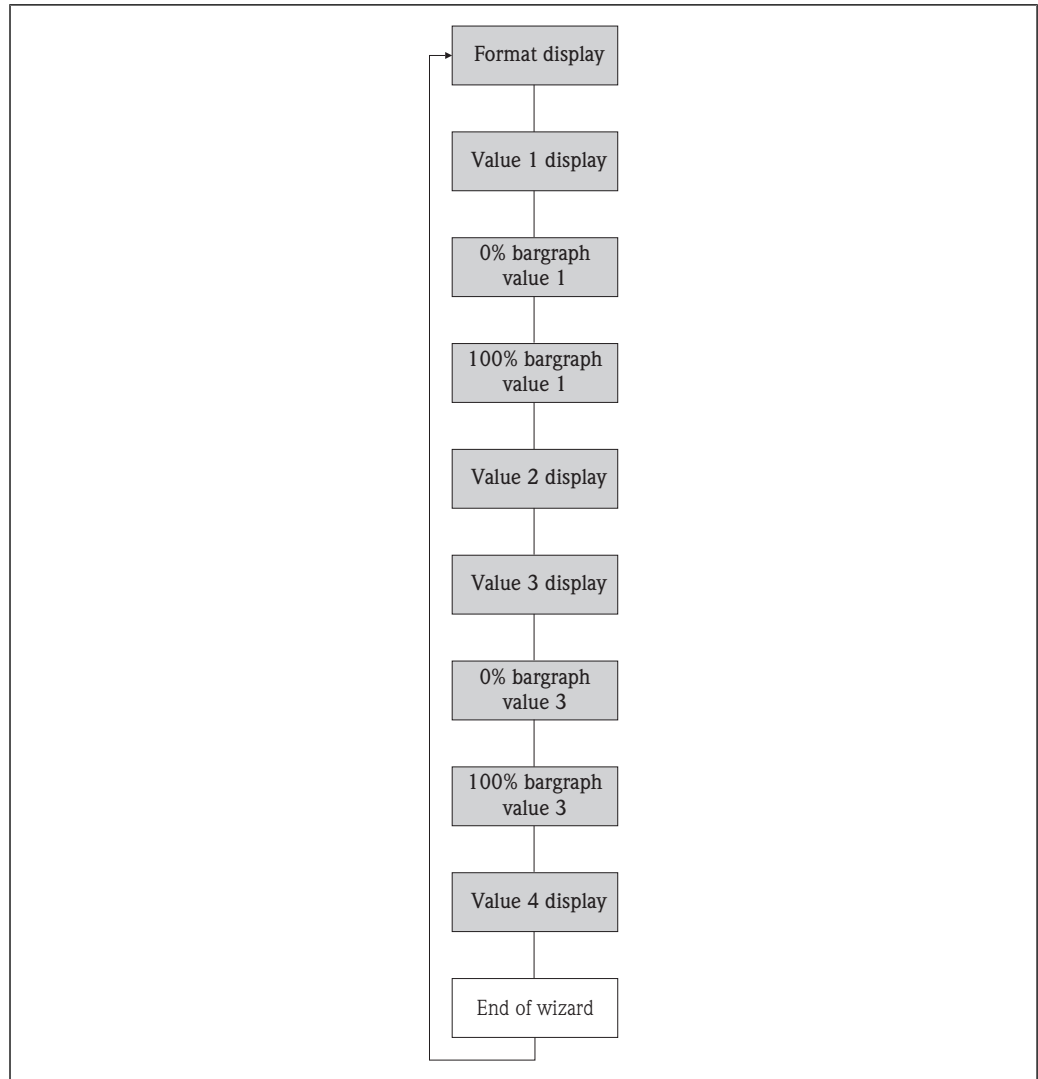

A0013797-EN

21 "Display" wizard in the "Setup" menu

Parameter overview with brief description

| Parameters | Description | Selection/ User entry | Factory setting |
|---------------------|--|---|--|
| Format display | Select how measured values are shown on the display. | <ul style="list-style-type: none"> ■ 1 value, max. ■ 1 bargraph + 1 value ■ 2 values ■ 1 value large + 2 values ■ 4 values | 1 value, max. |
| Value 1 display | Select the measured value that is shown on the local display. | <ul style="list-style-type: none"> ■ Volume flow ■ Mass flow ■ Totalizer 1 ■ Totalizer 2 ■ Totalizer 3 ■ Current output 1 | Volume flow |
| 0% bargraph value 1 | Enter the 0% value to be shown on the bargraph display for the measured value 1. | Floating point number with sign | Country-dependent: <ul style="list-style-type: none"> ■ 0 l/h ■ 0 af/min |

| | | | |
|-----------------------|--|---|--|
| 100% bargraph value 1 | Enter the 100% value to be shown on the bargraph display for the measured value 1. | Floating point number with sign | Depends on country and nominal diameter |
| Value 2 display | Select the measured value that is shown on the local display. | <ul style="list-style-type: none"> ■ None ■ Volume flow ■ Mass flow ■ Totalizer 1 ■ Totalizer 2 ■ Totalizer 3 ■ Current output 1 | None |
| Value 3 display | Select the measured value that is shown on the local display. | <ul style="list-style-type: none"> ■ None ■ Volume flow ■ Mass flow ■ Totalizer 1 ■ Totalizer 2 ■ Totalizer 3 ■ Current output 1 | None |
| 0% bargraph value 3 | Enter the 0% value to be shown on the bargraph display for the measured value 3. | Floating point number with sign | Country-dependent: <ul style="list-style-type: none"> ■ 0 l/h ■ 0 af/min |
| 100% bargraph value 3 | Enter the 100% value to be shown on the bargraph display for the measured value 3. | Floating point number with sign | Depends on country and nominal diameter |
| Value 4 display | Select the measured value that is shown on the local display. | <ul style="list-style-type: none"> ■ None ■ Volume flow ■ Mass flow ■ Totalizer 1 ■ Totalizer 2 ■ Totalizer 3 ■ Current output 1 | None |

10.4.4 Configuring the output conditioning

The **Output conditioning** wizard guides you systematically through all parameters that have to be set for configuring the output conditioning.

Navigation path

"Setup" menu → Output conditioning

Structure of the wizard

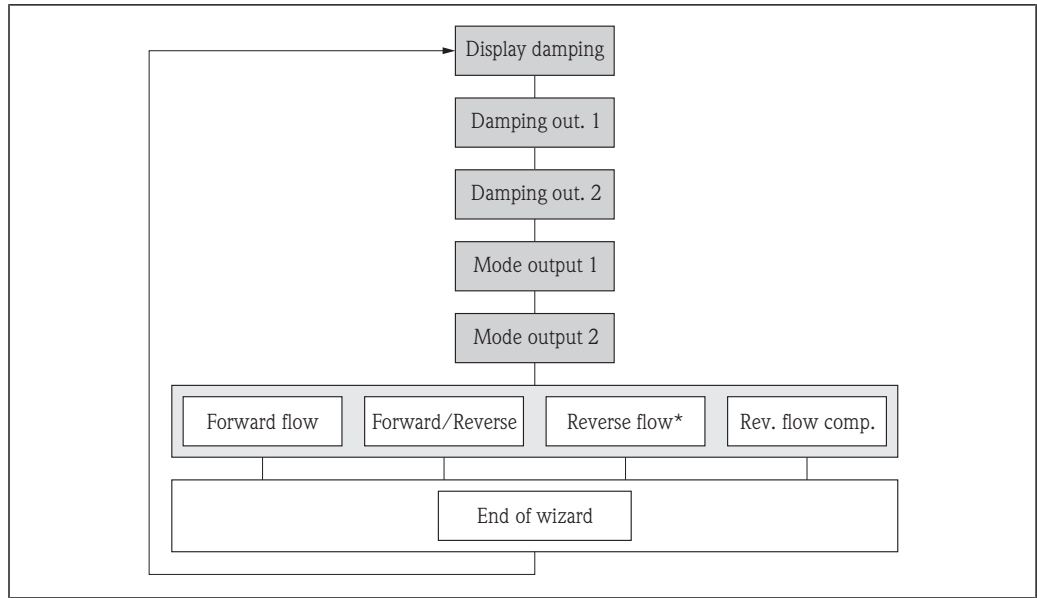

A0018583-EN

22 "Output conditioning" wizard in the "Setup" menu

Reverse flow* = option only for pulse and frequency output

Parameter overview with brief description

| Parameters | Description | Selection/ User entry | Factory setting |
|---------------------------|--|---|-----------------|
| Display damping | Set the reaction time of the local display to fluctuations in the measured value caused by process conditions. | 0 to 999 s | 0 s |
| Damping output 1-2 | Set the reaction time of the output signal to fluctuations in the measured value caused by process conditions. | 0 to 999 s | 3 s |
| Measuring mode output 1-2 | Select the measuring mode for output. | <ul style="list-style-type: none"> ■ Forward flow ■ Forward/reverse flow ■ Reverse flow (only for pulse and frequency output) ■ Reverse flow compensation | Forward flow |

10.4.5 Configuring the low flow cut off

The **Low flow cut off** wizard guides you systematically through all parameters that have to be set for configuring the low flow cut off.

Navigation path

"Setup" menu → Low flow cut off

Structure of the wizard

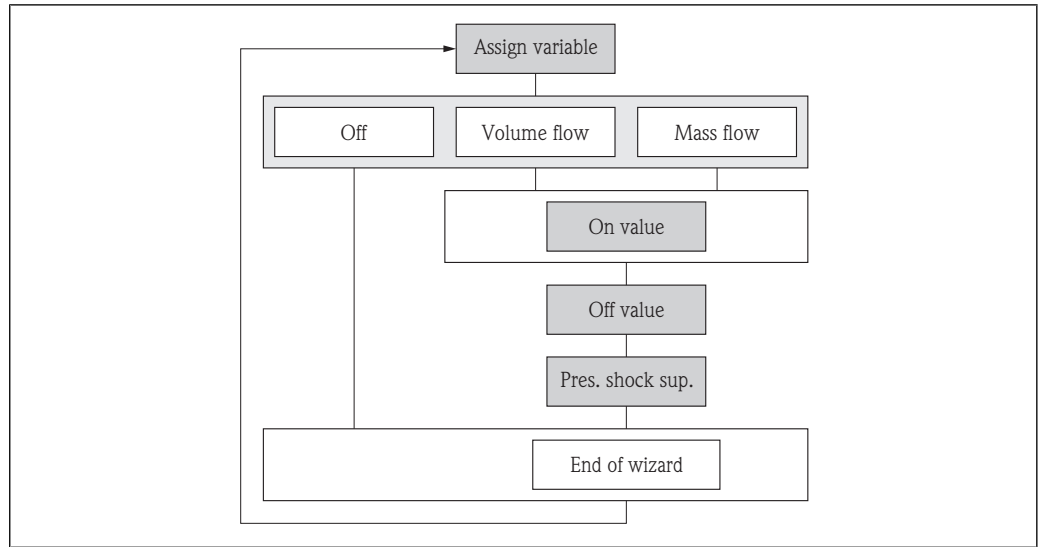

A0017209-EN

23 "Low flow cut off" wizard in the "Setup" menu

Parameter overview with brief description

| Parameter | Description | Selection/ User entry | Factory setting |
|----------------------------|---|---|-----------------|
| Assign process variable | Select process variable for low flow cut off. | <ul style="list-style-type: none"> ■ Off ■ Volume flow ■ Mass flow | Volume flow |
| Switch-on value | Enter the on value for low flow cut off. | Positive floating-point number | 0 |
| Switch-off value | Enter the off value for low flow cut off. | 0 to 100 % | 50 % |
| Pressure shock suppression | Enter the time interval for signal suppression (= active pressure shock suppression). | 0 to 100 s | 0 s |

10.4.6 Configuring empty pipe detection

The **Empty pipe detection (EPD)** wizard guides you systematically through all parameters that have to be set for configuring empty pipe detection.

Navigation path

"Setup" menu → Empty pipe detection

Structure of the wizard

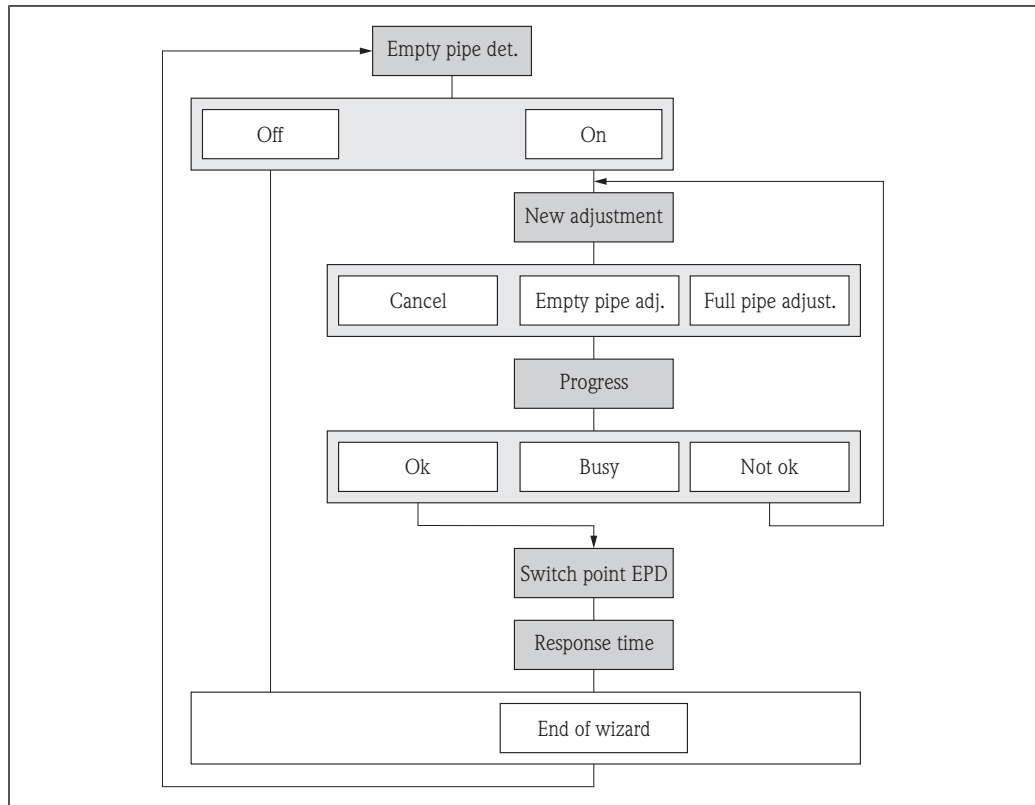

A0017210-EN

24 "Empty pipe detection" wizard in the "Setup" menu

Parameter overview with brief description

| Parameter | Description | Selection/ User entry | Factory setting |
|------------------------------------|---|---|-----------------|
| Empty pipe detection | Switch empty pipe detection on and off. | <ul style="list-style-type: none"> ■ Off ■ On | Off |
| New adjustment | Select the type of adjustment. | <ul style="list-style-type: none"> ■ Cancel ■ Empty pipe adjustment ■ Full pipe adjustment | Cancel |
| Progress | Progress display | – | – |
| Switch point empty pipe detection | Enter the switch point for empty pipe detection. | 1 to 99 % | 10 % |
| Response time empty pipe detection | Enter the time interval until the diagnostic message S862 Empty pipe detection is displayed for an empty or partially filled pipe. | 0 to 100 s | 1 s |

10.5 Advanced settings

The **Advanced setup** menu with its submenus contains all parameters needed for specific settings.

Navigation path

"Setup" menu → Advanced setup

Navigation to the "Advanced setup" submenu

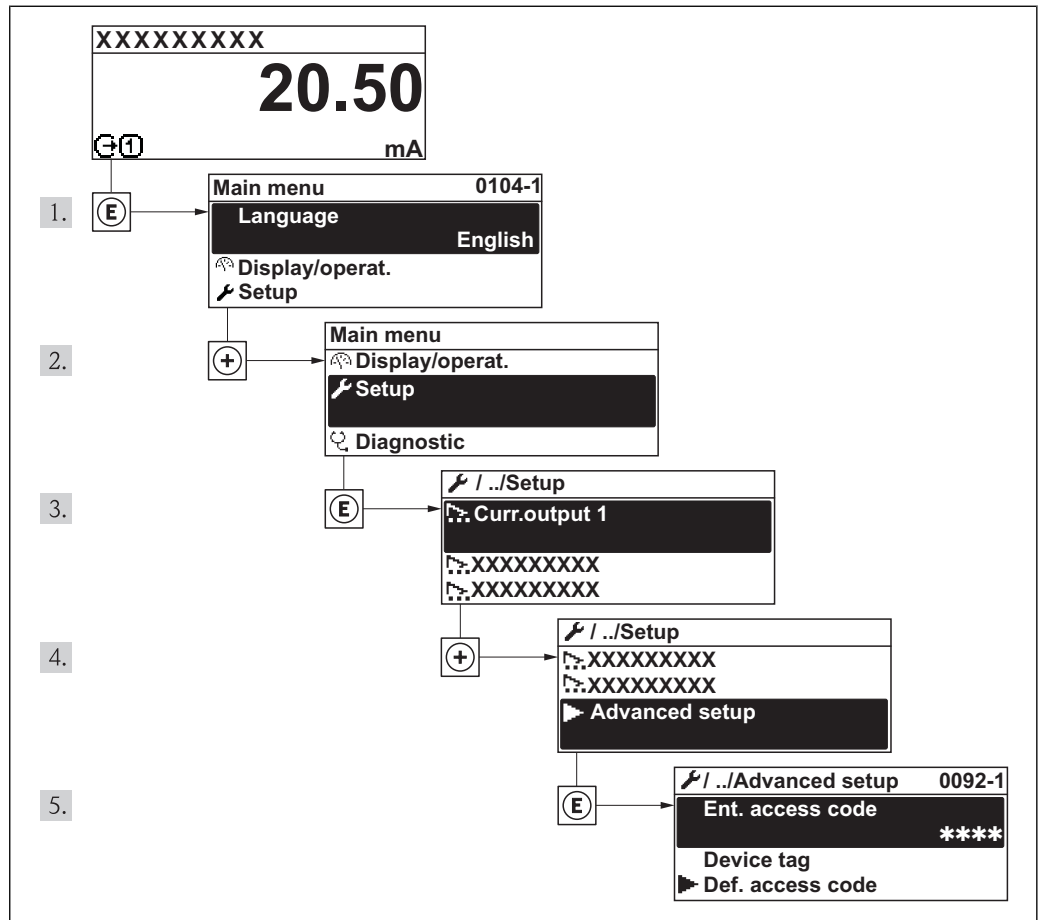

A0018745-EN

Overview of the parameters and submenus in the "Advanced setup" menu

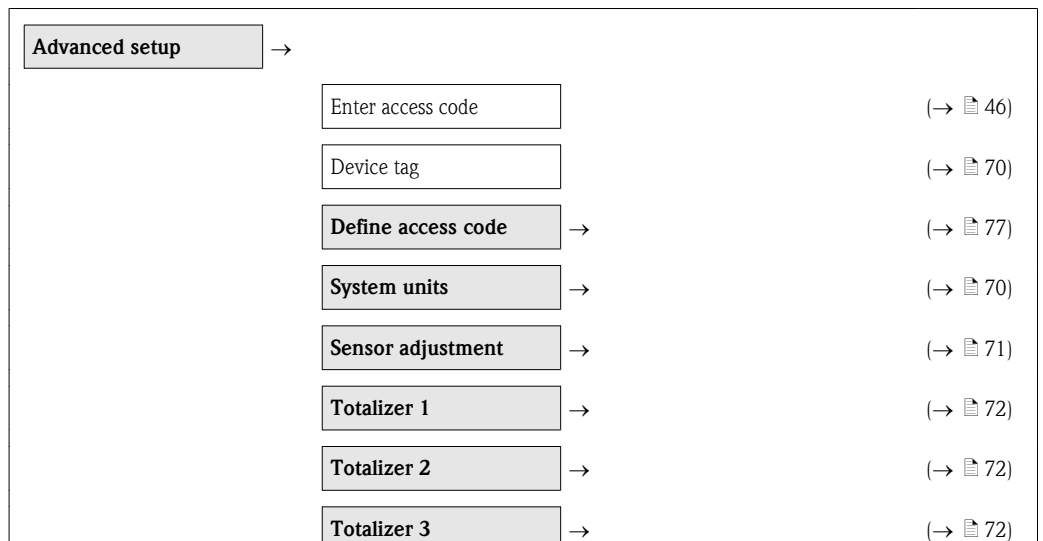

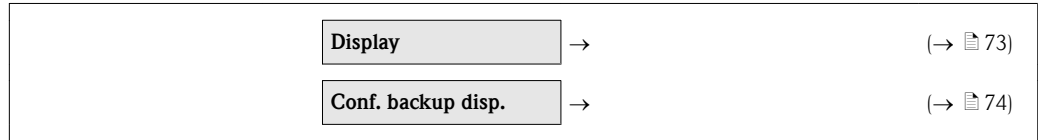

10.5.1 Defining the tag name

To enable quick identification of the measuring point within the system, you can enter a unique designation using the **Device tag** parameter and thus change the factory setting.

Navigation path

Setup → Advanced setup → Device tag

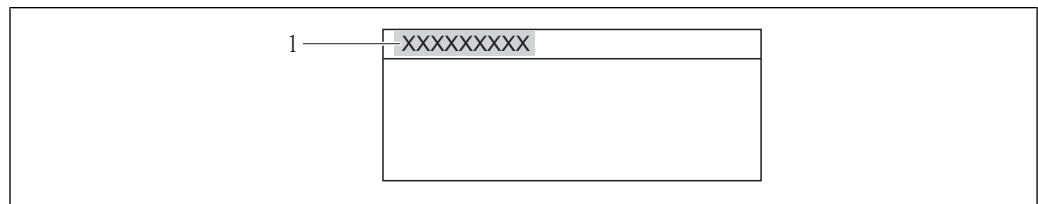

A0013375

25 Header of the operational display with tag name

1 Device tag

Parameter overview with brief description

| Parameter | Prerequisite | Description | User entry | Factory setting |
|------------|--|---|---|-----------------|
| Device tag | The following option is selected in the Header parameter: Device tag | Enter the name for the measuring point. | Max. 32 characters, such as letters, numbers or special characters (e.g. @, %, /) | Promag |

i The number of characters displayed depends on the characters used.

10.5.2 Setting the system units

In the **System units** submenu, you can configure the units of all measured values.

Navigation path

"Setup" menu → Advanced setup → System units

Structure of the submenu

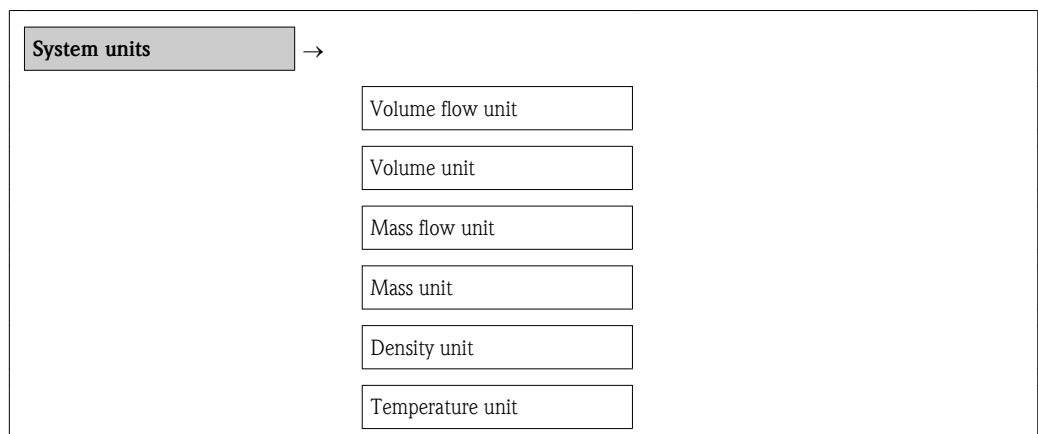

Parameter overview with brief description

| Parameter | Description | Selection/ | Factory setting |
|------------------|---|------------------|---|
| Volume flow unit | Select the unit for volume flow. <i>Result</i> The selected unit applies for: – Outputs – Low flow cut off – Simulation process variable | Unit choose list | Country-dependent: ■ m ³ /h ■ gal/min |
| Volume unit | Select the unit for volume. <i>Result</i> The selected unit applies for: Pulse value | Unit choose list | Country-dependent: ■ m ³ ■ gal |
| Mass flow unit | Select the unit for mass flow. <i>Result</i> The selected unit applies for: – Outputs – Low flow cut off – Simulation process variable | Unit choose list | Country-dependent: ■ kg/h ■ lbs/min |
| Mass unit | Select the unit for mass. <i>Result</i> The selected unit applies for: Pulse value | Unit choose list | Country-dependent: ■ kg ■ lbs |
| Density unit | Select the unit for density. <i>Result</i> The selected unit applies for: Fixed density | Unit choose list | Country-dependent ■ kg/l ■ g/cc |
| Temperature unit | Select the unit for temperature. <i>Result</i> The selected unit applies for: Diagnostics: Min/max values | Unit choose list | Country-dependent: ■ °C (Celsius) ■ °F (Fahrenheit) |

10.5.3 Carrying out a sensor adjustment

The **Sensor adjustment** submenu contains parameters that pertain to the functionality of the sensor.

Navigation path

"Setup" menu → Advanced setup → Sensor adjustment

Structure of the submenu

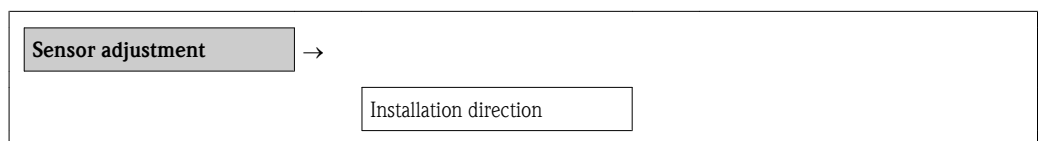

Parameter overview with brief description

| Parameter | Description | Selection/ | Factory setting |
|-----------|-------------|------------|-----------------|
|-----------|-------------|------------|-----------------|

| | | | |
|------------------------|--|---|-------------------------|
| Installation direction | Change the sign of the direction of flow of the fluid. | <ul style="list-style-type: none"> ■ Flow in arrow direction ■ Flow against arrow direction | Flow in arrow direction |
|------------------------|--|---|-------------------------|

10.5.4 Configuring the totalizer

You can configure each totalizer in the three submenus **Totalizer 1-3**.

Navigation path

"Setup" menu → Advanced setup → Totalizer 1

"Setup" menu → Advanced setup → Totalizer 2

"Setup" menu → Advanced setup → Totalizer 3

Structure of the submenu

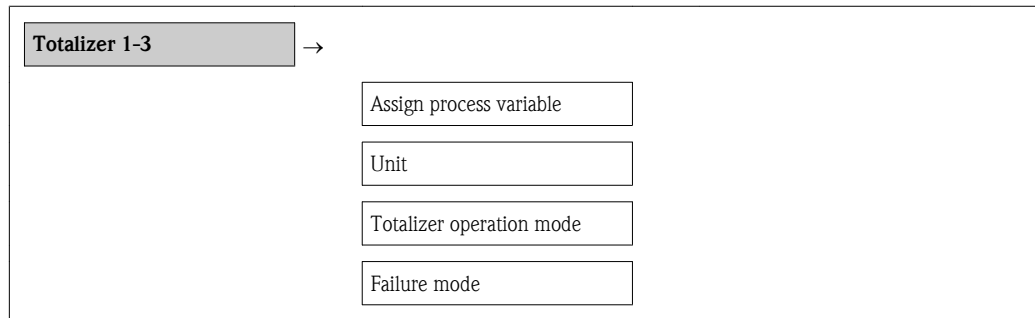

Parameter overview with brief description

| Parameters | Prerequisite | Description | Selection/ | Factory setting |
|--------------------------|--|---|--|---|
| Assign process variable | - | Select process variable for totalizer. <i>Result</i> The selection determines the choose list of the Unit parameter. | <ul style="list-style-type: none"> ■ Off ■ Volume flow ■ Mass flow | Volume flow |
| Unit | One of the following options is selected in the Assign process variable parameter: <ul style="list-style-type: none"> ■ Volume flow ■ Mass flow | Select the unit for the process variable of the totalizer. | Unit choose list | Depends on country and nominal diameter |
| Totalizer operation mode | One of the following options is selected in the Assign process variable parameter: <ul style="list-style-type: none"> ■ Volume flow ■ Mass flow | Select totalizer calculation mode. | <ul style="list-style-type: none"> ■ Net flow total ■ Forward flow total ■ Reverse flow total | Net flow total |
| Failure mode | One of the following options is selected in the Assign process variable parameter: <ul style="list-style-type: none"> ■ Volume flow ■ Mass flow | Define how the totalizer behaves in an alarm condition. | <ul style="list-style-type: none"> ■ Stop ■ Actual value ■ Last valid value | Stop |

10.5.5 Carrying out additional display configurations

In the **Display** submenu, you can set all parameters involved in the configuration of the local display.

Navigation path

"Setup" menu → Advanced setup → Display

Structure of the submenu

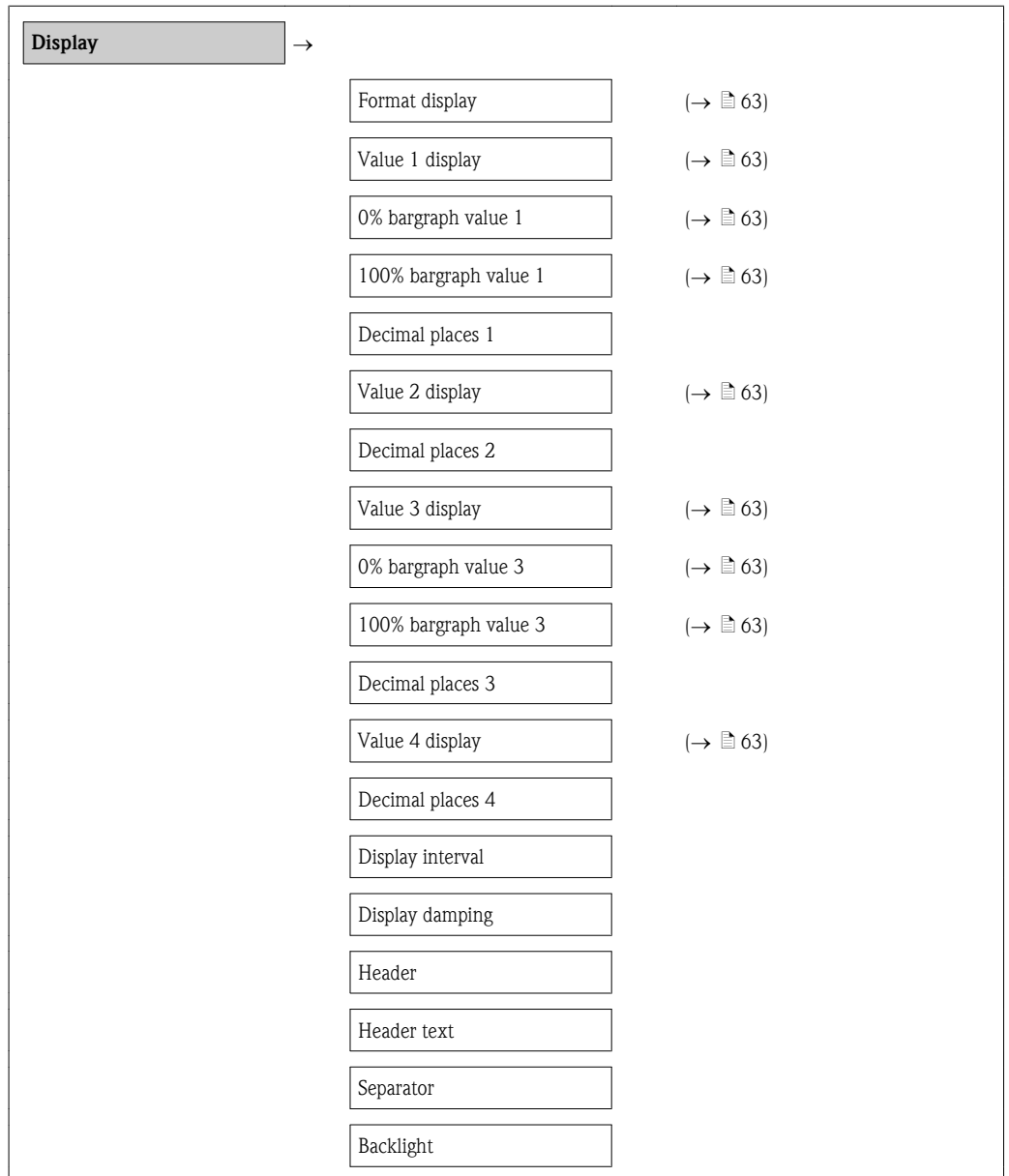

Parameter overview with brief description

| Parameters | Prerequisite | Description | Selection/ User entry | Factory setting |
|------------------|---|--|---|-----------------|
| Decimal places 1 | A measured value is specified in the parameter Value 1 display . | Select the number of decimal places for the display value. | <ul style="list-style-type: none"> ■ x ■ x.x ■ x.xx ■ x.xxx ■ x.xxxx | x.xx |

| | | | | |
|------------------|---|--|---|------------|
| Decimal places 2 | A measured value is specified in the parameter Value 2 display . | Select the number of decimal places for the display value. | <ul style="list-style-type: none"> ■ x ■ x.x ■ x.xx ■ x.xxx ■ x.xxxx | x.xx |
| Decimal places 3 | A measured value is specified in the parameter Value 3 display . | Select the number of decimal places for the display value. | <ul style="list-style-type: none"> ■ x ■ x.x ■ x.xx ■ x.xxx ■ x.xxxx | x.xx |
| Decimal places 4 | A measured value is specified in the parameter Value 4 display . | Select the number of decimal places for the display value. | <ul style="list-style-type: none"> ■ x ■ x.x ■ x.xx ■ x.xxx ■ x.xxxx | x.xx |
| Display interval | - | Set time measured values are shown on display if display alternates between values. | 1 to 10 s | 5 s |
| Display damping | - | Set the reaction time of the local display to fluctuations in the measured value caused by process conditions. | 0 to 999 s | 0 s |
| Header | - | Select header contents on local display | <ul style="list-style-type: none"> ■ Device tag ■ Free text | Device tag |
| Header text | The Free text option is selected in the Header parameter. | Enter display header text. | Max. 12 characters such as letters, numbers or special characters | ----- |
| Separator | - | Select decimal separator for displaying numerical values. | <ul style="list-style-type: none"> ■ . (point) ■ , (comma) | . (point) |
| Backlight | - | Switch the backlight of the local display on and off. | <ul style="list-style-type: none"> ■ Disable ■ Enable | Enable |

10.6 Configuration management

After commissioning, you can save the current device configuration, copy it to another measuring point or restore the previous device configuration.

You can do so using the **Configuration management** parameter and the related options found in the **Conf. backup disp.** submenu.

Navigation path

"Setup" menu → Advanced setup → Conf. backup disp.

Function scope of the "Configuration management" parameter

| Options | Description |
|-------------------|--|
| Execute backup | The current device configuration is backed up from the integrated HistoROM to the device's display module. The backup copy includes the transmitter data of the device. |
| Restore | The last backup copy of the device configuration is restored from the display module to the device's integrated HistoROM DAT. The backup copy includes the transmitter data of the device. |
| Duplicate | The transmitter configuration from another device is duplicated to the device using the display module. |
| Compare | The device configuration saved in the display module is compared with the current device configuration of the integrated HistoROM. |
| Clear backup data | The backup copy of the device configuration is deleted from the display module of the device. |

 **Integrated HistoROM**

A HistoROM is a "non-volatile" device memory in the form of an EEPROM.

 While this action is in progress, the configuration cannot be edited via the local display and a message on the processing status appears on the display.

Structure of the submenu

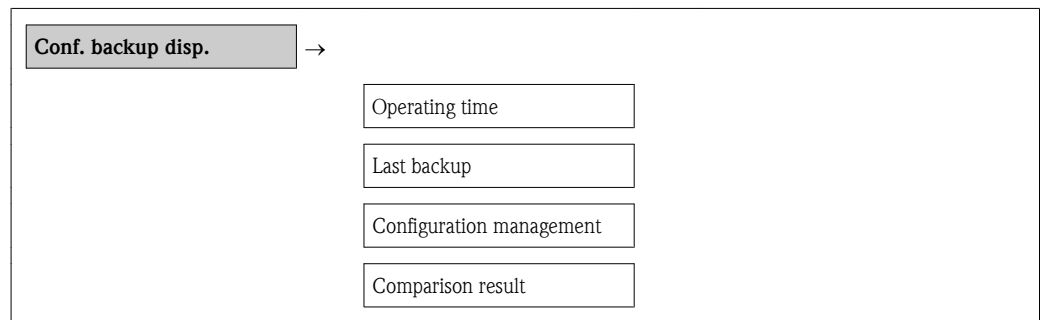

Parameter overview with brief description

| Parameters | Description | Selection/Display | Factory setting |
|--------------------------|---|---|-----------------|
| Operating time | Indicates how long the device has been in operation up to this point. | Days (d), hours (h), minutes (m), seconds (s) | - |
| Last backup | Indicates when the last data backup was saved to the display module | Days (d), hours (h), minutes (m), seconds (s) | - |
| Configuration management | Select action for managing the device data in the display module | <ul style="list-style-type: none"> ■ Cancel ■ Execute backup ■ Restore ■ Duplicate ■ Compare ■ Clear backup data | Cancel |
| Comparison result | Comparison between present device data and display backup | <ul style="list-style-type: none"> ■ Set. identical ■ Set. not ident. ■ No backup ■ Backup corrupt ■ Check not done ■ Dataset incomp. | Check not done |

10.7 Simulation

The **Simulation** submenu enables you to simulate, without a real flow situation, various process variables in the process and the device alarm mode and to verify downstream signal chains (switching valves or closed-control loops).

Navigation path

"Diagnostics" menu → Simulation

Structure of the submenu

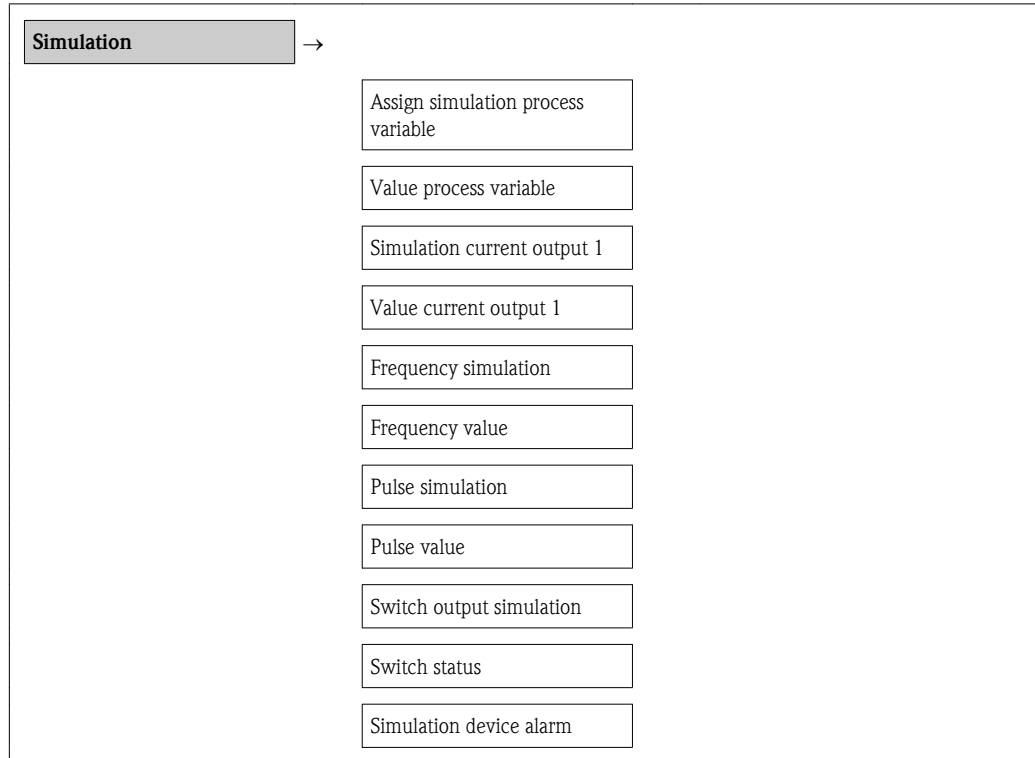

Parameter overview with brief description

| Parameters | Prerequisite | Description | Selection/ User entry | Factory setting |
|------------------------------------|---|---|---|----------------------------------|
| Assign simulation process variable | - | Select a process variable for the simulation process that is activated. | <ul style="list-style-type: none"> ■ Off ■ Volume flow ■ Mass flow | Off |
| Value process variable | One of the following options is selected in the Assign simulation process variable parameter: <ul style="list-style-type: none"> ■ Volume flow ■ Mass flow | Enter the simulation value for the selected process variable. | Depends on the process variable selected | - |
| Simulation current output | - | Switch simulation of the current output on and off. | <ul style="list-style-type: none"> ■ Off ■ On | Off |
| Value current output | The On option is selected in the Simulation current output 1-2 parameter. | Enter the current value for simulation. | 3.6 to 22.5 mA | Current value currently measured |
| Frequency simulation | - | Switch simulation of the frequency output on and off. | <ul style="list-style-type: none"> ■ Off ■ On | Off |

| | | | | |
|--------------------------|---|--|---|------------------------------|
| Frequency value | The On option is selected in the Frequency output simulation parameter. | Enter the frequency value for simulation. | 0 to 1 250 Hz | Frequency currently measured |
| Pulse simulation | - | Set and switch off pulse output simulation. | <ul style="list-style-type: none"> ■ Off ■ Fixed value ■ Down-count val. <p>i If the Fixed value option is selected, the Pulse width parameter defines the pulse width of the pulses output (→ 58).</p> | Off |
| Pulse value | The Down-count. val. option is selected in the Simulation pulse output parameter. | Enter the number of pulses for simulation. | 0 to 65535 | Pulse currently measured |
| Switch output simulation | - | Switch the simulation of the switch output on and off. | <ul style="list-style-type: none"> ■ Off ■ On | Off |
| Switch status | The On option is selected in the Switch output simulation parameter. | Select the status of the status output for the simulation. | <ul style="list-style-type: none"> ■ Open ■ Closed | Open |
| Simulation device alarm | - | Switch the device alarm on and off. | <ul style="list-style-type: none"> ■ Off ■ On | Off |

10.8 Protecting settings from unauthorized access

The following options exist for protecting the configuration of the measuring device from unintentional modification after commissioning:

- Write protection via access code (→ 77)
- Write protection via write protection switch (→ 78)
- Write protection via keypad lock (→ 46)

10.8.1 Write protection via access code

With the customer-specific access code, the parameters for the measuring device configuration are write-protected and their values can no longer be changed via local operation.

Navigation path

"Setup" menu → Advanced setup → Define access code

Structure of the submenu

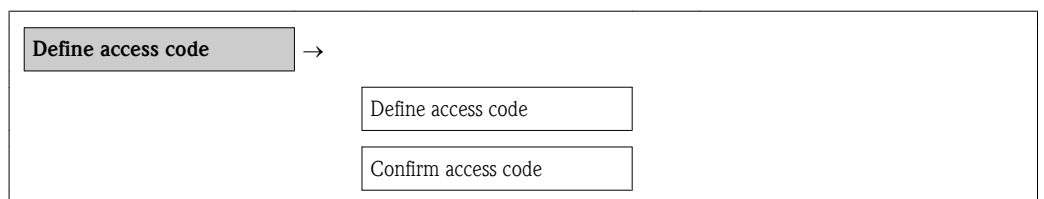

Defining the access code via local display

1. Navigate to the **Define access code** parameter.

2. Define a max. 4-digit numeric code as an access code.
3. Enter the access code again to confirm the code.
 - ✓ The -symbol appears in front of all write-protected parameters.

The device automatically locks the write-protected parameters again if a key is not pressed for 10 minutes in the navigation and editing view. The device locks the write-protected parameters automatically after 60 s if the user skips back to the operational display mode from the navigation and editing view.

-  If write access is activated via access code, it can be also be deactivated only via the access code (→ [46](#)).
- The user role with which the user is currently logged on via the local display (→ [46](#)) is indicated by the **Access status display** parameter. Navigation path: Display/operation → Access status display

Parameters which can always be modified via the local display

Certain parameters that do not affect the measurement are excepted from write protection via the local display. Despite the defined access code, these parameters can always be modified even if the other parameters are locked.

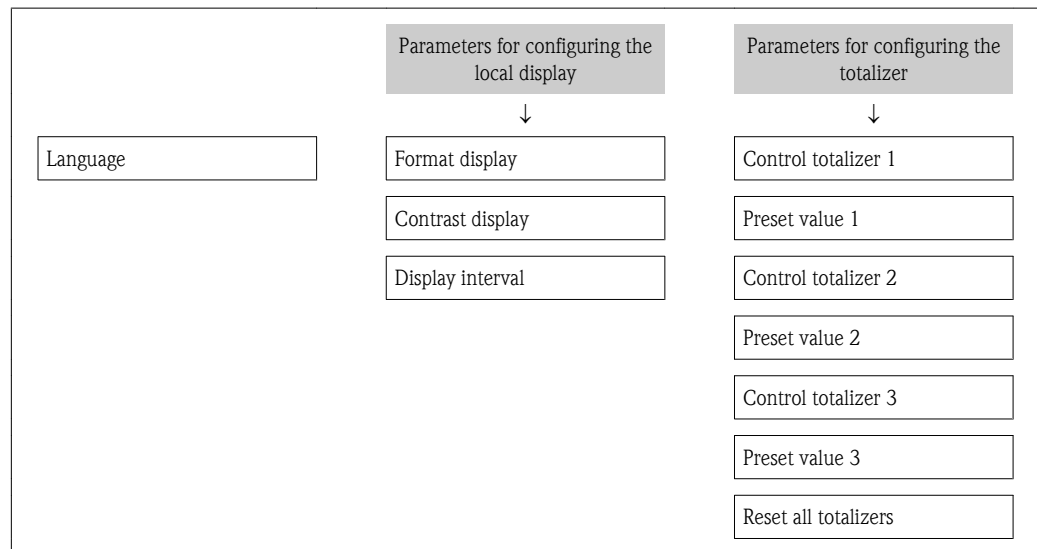

10.8.2 Write protection via write protection switch

Unlike write protection via user-specific access code, this allows write access to the entire operating menu - other than the **Contrast display** parameter - to be locked.

The parameter values are now read only and cannot be edited any more (exception **Contrast display**):

- Via local display
- Via service interface (CDI)
- Via HART protocol

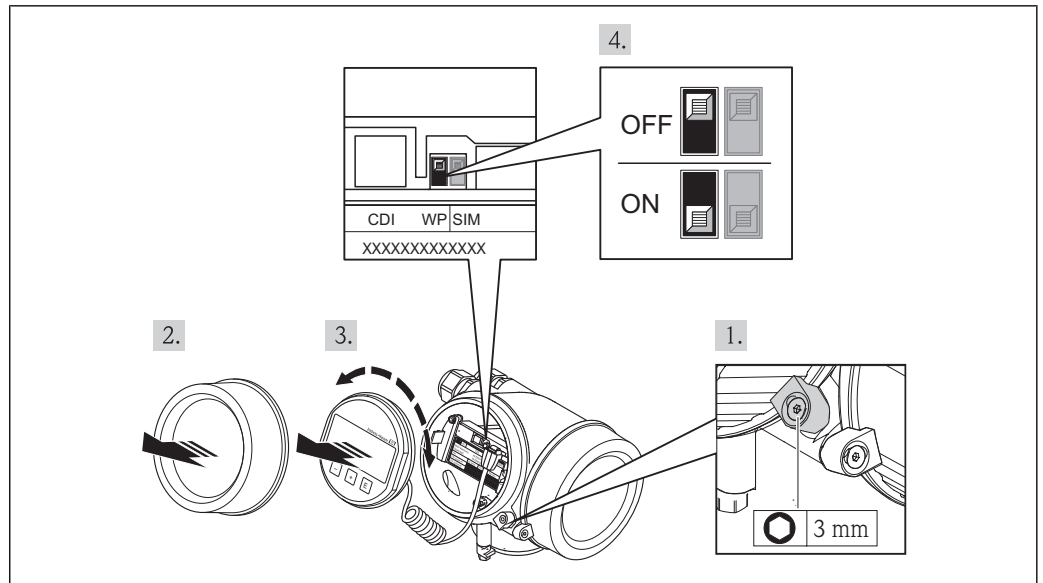

A0013768

1. Loosen the securing clamp.
2. Unscrew the electronics compartment cover.
3. Pull out the display module with a gentle rotational movement. To make it easier to access the lock switch, attach the display module to the edge of the electronics compartment.

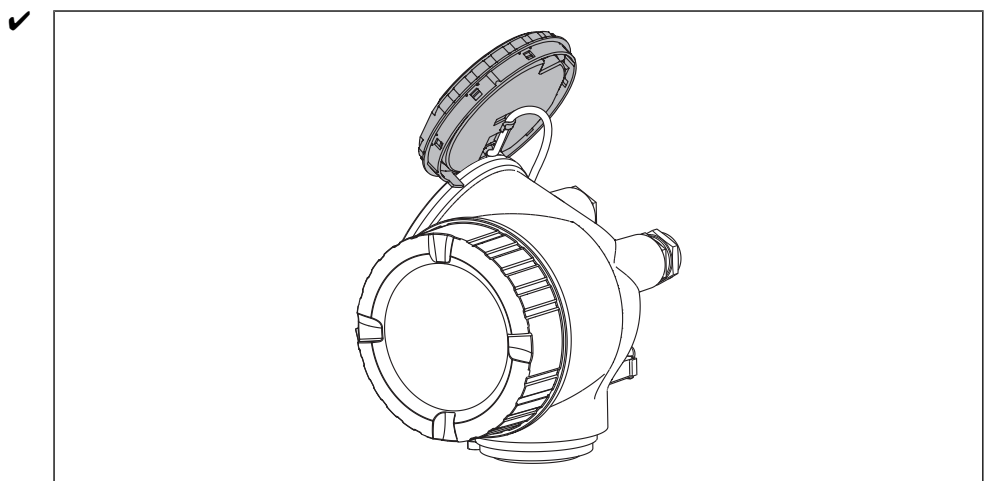

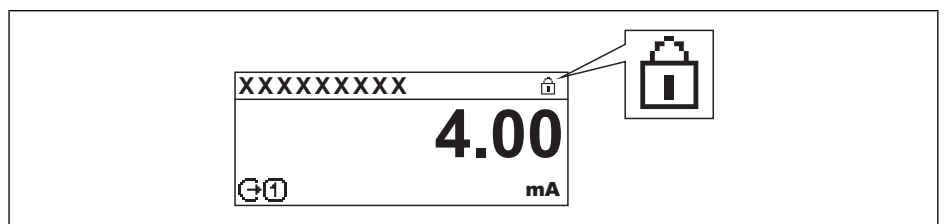

A0013909

4. Setting the write protection switch (WP) on the main electronics module to the ON position enables the hardware write protection. Setting the write protection switch (WP) on the main electronics module to the OFF position (factory setting) disables the hardware write protection.
 - ✓ If hardware write protection is enabled, the **Hardware locked** option is displayed in the **Locking status** parameter (→ 81). In addition, on the local display the -symbol appears in front of the parameters in the header of the operational display and in the navigation view.



A0015870

If hardware write protection is disabled, no option is displayed in the **Locking status** parameter (→  81). On the local display, the -symbol disappears from in front of the parameters in the header of the operational display and in the navigation view.

5. Feed the spiral cable into the gap between the housing and main electronics module and plug the display module into the electronics compartment in the desired direction until it engages.
6. Reverse the removal procedure to reassemble the transmitter.

11 Operation

11.1 Read device locking status

The write protection types that are currently active can be determined using the **Locking status** parameter.

Navigation path

"Expert" menu → Locking status

Function scope of "Locking status" parameter

| Options | Description |
|--------------------|---|
| None | The access status displayed in the Access status display parameter apply (→ 46). Only appears on local display. |
| Hardware locked | The DIP switch for hardware locking is activated on the main electronics module. This locks write access to the parameters (→ 78). |
| Temporarily locked | Write access to the parameters is temporarily locked due to internal device processing (e.g. data upload/download, reset). Once the internal processing has been completed, the parameters can be changed once again. |

11.2 Adjusting the operating language

Information (→ 53)



For information on the operating languages supported by the measuring device (→ 120)

11.3 Configuring the display

- Basic settings for local display (→ 63)
- Advanced settings for local display (→ 73)

11.4 Reading off measured values

You can read all measured values using the **Measured values** menu.

Navigation path

Diagnostics → Measured values

11.4.1 Process variables

The **Process variables** submenu contains all the parameters needed to display the current measured values for every process variable.

Navigation path

"Diagnostics" menu → Measured values → Process variables

Structure of the submenu

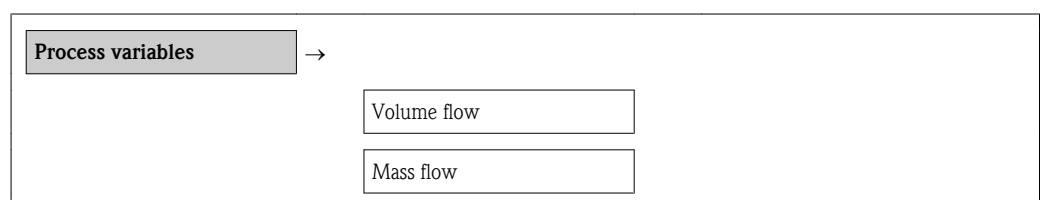

Parameter overview with brief description

| Parameter | Description | Display |
|-------------|---|---------------------------------|
| Volume flow | Displays the calculated volume flow | Floating-point number with sign |
| Mass flow | Displays the mass flow currently calculated | Floating-point number with sign |

11.4.2 Totalizer

The **Totalizer** submenu contains all the parameters needed to display the current measured values for every totalizer.

Navigation path

"Diagnostics" menu → Measured values → Totalizer

Structure of the submenu

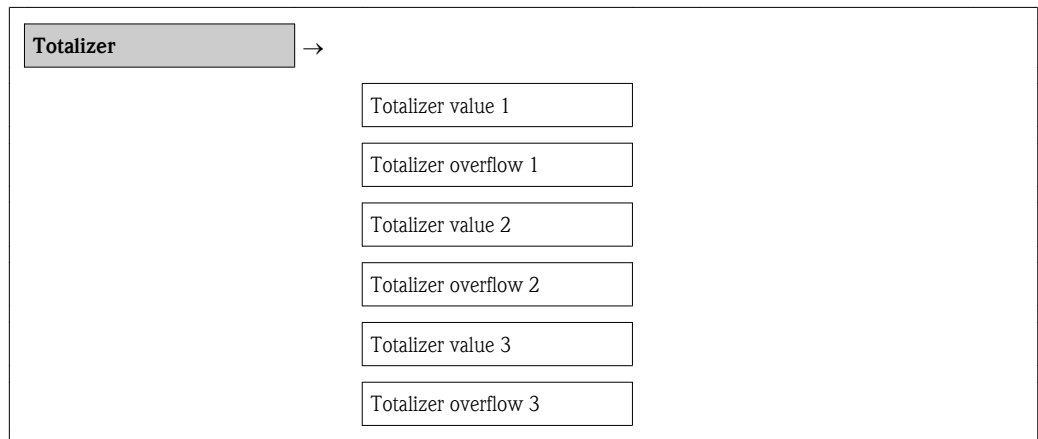

Parameter overview with brief description

| Parameters | Prerequisite | Description | Display |
|------------------------|---|---|---------------------------------|
| Totalizer value 1-3 | One of the following options is selected in the Assign process variable parameter of the Totalizer 1-3 submenu: <ul style="list-style-type: none"> ■ Volume flow ■ Mass flow | Displays the current totalizer counter value. | Floating point number with sign |
| Totalizer overflow 1-3 | One of the following options is selected in the Assign process variable parameter of the Totalizer 1-3 submenu: <ul style="list-style-type: none"> ■ Volume flow ■ Mass flow | Displays the current totalizer overflow. | Integer |

11.4.3 Output values

The **Output values** submenu contains all the parameters needed to display the current measured values for every output.

Navigation path

"Diagnostics" menu → Measured values → Output values

Structure of the submenu

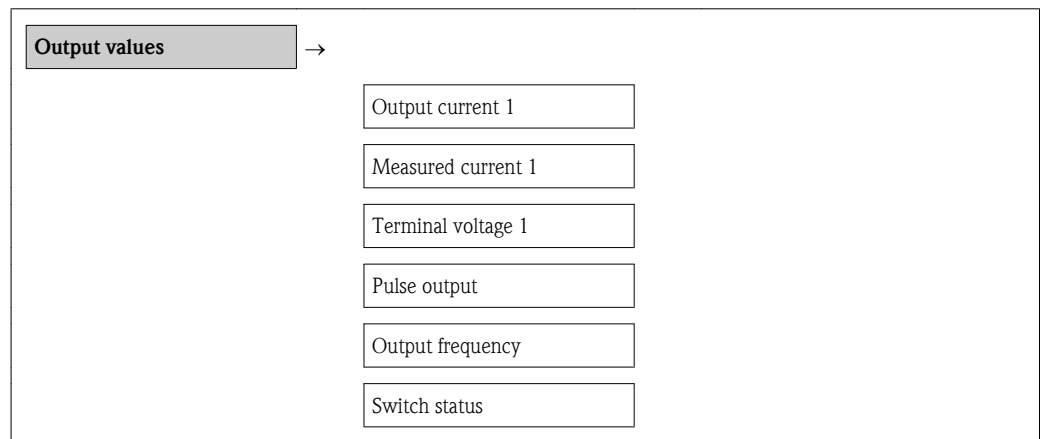

Parameter overview with brief description

| Parameters | Prerequisite | Description | Display |
|--------------------|--------------|--|--|
| Output current | - | Displays the current value currently calculated for the current output. | 3.59 to 22.5 mA |
| Measured current 1 | - | Displays the current value currently measured for the current output. | 3.59 to 22.5 mA |
| Terminal voltage 1 | - | Displays the current terminal voltage that is applied at the current output. | - |
| Pulse output | - | Displays the value currently measured for the pulse output. | Positive floating-point number |
| Output frequency | - | Displays the value currently measured for the frequency output. | 0 to 1 250 Hz |
| Switch status | - | Displays the current switch output status. | <ul style="list-style-type: none"> ■ Open ■ Closed |

11.5 Adapting the measuring device to the process conditions

The following are available for this purpose:

- Basic settings using the **Setup** menu (→ 54)
- Advanced settings using the **Advanced setup** menu (→ 69)

11.6 Performing a totalizer reset

In the **Operation** submenu, 2 parameters with various options for resetting the three totalizers are available:

- Control totalizer 1-3
- Reset all totalizers

Navigation path

"Display/operat." menu → Operation

Function scope of the "Control totalizer" parameter

| Options | Description |
|-------------------|---|
| Totalize | The totalizer is started. |
| Reset + hold | The totaling process is stopped and the totalizer is reset to 0. |
| Preset + hold | The totaling process is stopped and the totalizer is set to the defined start value in the Preset parameter. |
| Reset + totalize | The totalizer is reset to 0 and the totaling process is restarted. |
| Preset + totalize | The totalizer is set to the defined start value in the Preset parameter and the totaling process is restarted. |

Function scope of the "Reset all totalizers" parameter

| Options | Description |
|------------------|--|
| Reset + totalize | Resets all totalizers to 0 and restarts the totaling process. This deletes all the flow values previously totalized. |

"Operation" submenu

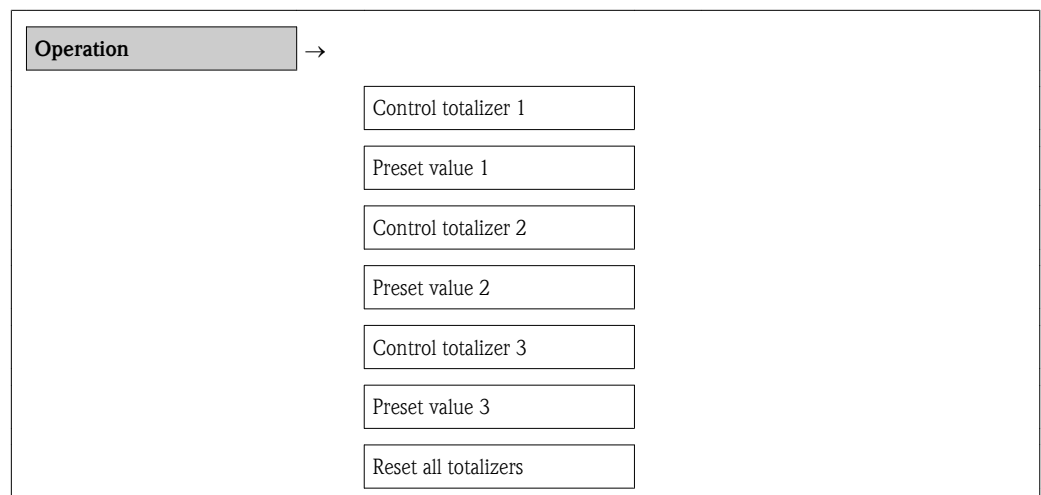

Parameter overview with brief description

| Parameter | Prerequisite | Description | Selection/ User entry | Factory setting |
|-----------------------|--------------|--------------------------------------|--|-----------------|
| Control totalizer 1-3 | | Control totalizer value. | <ul style="list-style-type: none"> ■ Totalize ■ Reset + hold ■ Preset + hold ■ Reset + totalize ■ Preset + totalize | Totalize |
| Preset value 1-3 | | Specify start value for totalizer. | Floating point number with sign | |
| Reset all totalizers | - | Reset all totalizers to 0 and start. | <ul style="list-style-type: none"> ■ Cancel ■ Reset + totalize | Cancel |

11.7 Showing data logging

In the device, the extended function of the HistoROM must be enabled (order option) so that the **Data logging** submenu appears. This contains all parameters for the measured value history.

Navigation path

"Diagnostics" menu → Data logging

Function scope

- A total of 1000 measured values can be stored
- 4 logging channels
- Adjustable logging interval for data logging
- Display of the measured value trend for each logging channel in the form of a chart

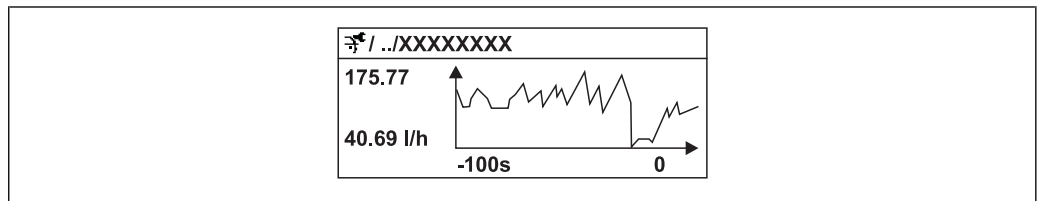

26 Chart of a measured value trend

- x-axis: depending on the number of channels selected displays 250 to 1000 measured values of a process variable.
- y-axis: displays the approximate measured value span and constantly adapts this to the ongoing measurement.

i If the length of the logging interval or the assignment of the process variables to the channels is changed, the content of the data logging is deleted.

"Data logging" submenu

Data logging →

- Assign channel 1
- Assign channel 2
- Assign channel 3
- Assign channel 4
- Logging interval
- Clear logging data
- Display channel 1
- Display channel 2
- Display channel 3
- Display channel 4

Parameter overview with brief description

| Parameters | Prerequisite | Description | Selection/ User entry | Factory setting |
|------------|--------------|-------------|--------------------------|-----------------|
|------------|--------------|-------------|--------------------------|-----------------|

| | | | | |
|---------------------|--|---|--|--------|
| Assign channel 1-4 | - | Assign process variable to logging channel. | <ul style="list-style-type: none"> ■ Off ■ Volume flow ■ Mass flow ■ Electronics temperature | Off |
| Logging interval | - | Define the logging interval t_{\log} for data logging. This value defines the time interval between the individual data points in the memory. | 1.0 to 3 600.0 s | 10.0 s |
| Clear logging data | - | Clear the entire logging data. | <ul style="list-style-type: none"> ■ Cancel ■ Clear data | Cancel |
| Display channel 1-4 | One of the following options is selected in the Assign channel 1-4 parameter: <ul style="list-style-type: none"> ■ Volume flow ■ Mass flow ■ Electronics temperature | Displays the measured value trend for the logging channel in the form of a chart. | - | - |

12 Diagnostics and troubleshooting

12.1 General troubleshooting

For local display







| Problem | Possible cause | Remedy |
|---|--|--|
| Local display dark and no output signals | Supply voltage does not match that specified on the nameplate. | Apply the correct supply voltage (→ 29). |
| Local display dark and no output signals | Supply voltage has incorrect polarity. | Reverse polarity of supply voltage. |
| Local display dark and no output signals | No contact between connecting cables and terminals. | Check the contacting of the cables and correct if necessary. |
| Local display dark and no output signals | Terminals are not plugged into the I/O electronics module correctly. | Check terminals. |
| Local display dark and no output signals | I/O electronics module is defective. | Order spare part (→ 102). |
| Local display is dark, but signal output is within the valid range | Display is set too bright or too dark. | <ul style="list-style-type: none"> ■ Set the display brighter by simultaneously pressing $\square + \square$. ■ Set the display darker by simultaneously pressing $\square + \square$. |
| Local display is dark, but signal output is within the valid range | Spiral cable of the display module is not plugged in correctly. | Insert the plug correctly into the main electronics module and display module. |
| Local display is dark, but signal output is within the valid range | Display module is defective. | Order spare part (→ 102). |
| Backlighting of local display is red | Diagnostic event with "Alarm" diagnostic behavior has occurred. | Take remedial measures (→ 93) |
| Text on local display appears in a foreign language and cannot be understood. | Incorrect operating language is configured. | <ol style="list-style-type: none"> 1. Press $\square + \square$ for 2 s ("home position"). 2. Press \square. 3. Set the desired language in the Language parameter. |

For output signals

| Problem | Possible cause | Remedy |
|---|--|---|
| Signal output outside the valid range | Main electronics module is defective. | Order spare part (→ 102). |
| Signal output outside the valid current range (< 3.6 mA or > 22 mA) | I/O electronics module is defective. | Order spare part (→ 102). |
| Device shows correct value on local display, but signal output is incorrect, though in the valid range. | Configuration error | Check and correct parameter configuration. |
| Device measures incorrectly. | Configuration error or device is operated outside the application. | <ol style="list-style-type: none"> 1. Check and correct parameter configuration. 2. Observe limit values specified in the "Technical Data". |

For access

| Problem | Possible cause | Remedy |
|-------------------------------|-----------------------------------|--|
| No write access to parameters | Hardware write protection enabled | Set the write protection switch on the main electronics module to the OFF position (→ 78). |

| | | |
|-------------------------------------|---|---|
| No write access to parameters | Current user role has limited access authorization | 1. Check user role (→  46). 2. Enter correct customer-specific access code (→  46). |
| No connection via HART protocol | Missing or incorrectly installed communication resistor. | Install the communication resistor (250 Ω) correctly. Observe the maximum load (→  27)(→  107). |
| No connection via HART protocol | Commubox <ul style="list-style-type: none"> ■ Connected incorrectly ■ Configured incorrectly ■ Drivers not installed correctly ■ USB interface on computer configured incorrectly | Observe the documentation for the Commubox.  FXA195 HART: Document "Technical Information" TI00404F |
| No connection via service interface | Incorrect configuration of USB interface on PC or driver not installed correctly. | Observe the documentation for the Commubox.  FXA291: Document "Technical Information" TI00405C |

12.2 Diagnostic information on local display

12.2.1 Diagnostic message

Faults detected by the self-monitoring system of the measuring device are displayed as a diagnostic message in alternation with the operational display.

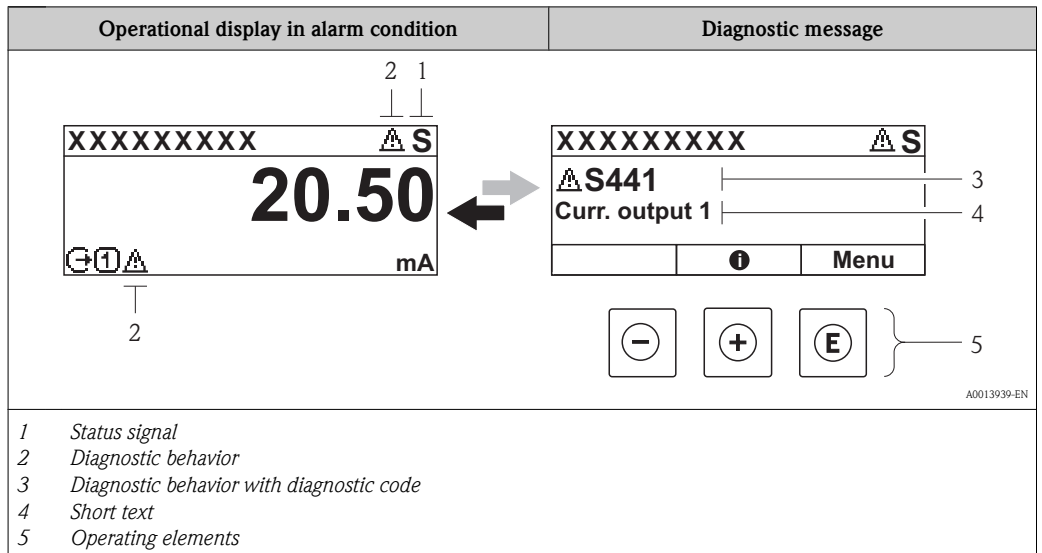

If two or more diagnostic events are pending simultaneously, only the message of the diagnostic event with the highest priority is shown.

- i** Other diagnostic events that have occurred can be called up in the **Diagnostics** menu:
 - Via parameters (→ 96)
 - Via submenus (→ 96)



Status signals

The status signals provide information on the state and reliability of the device by categorizing the cause of the diagnostic information (diagnostic event).

| Symbol | Meaning |
|-------------------------------------|--|
| F <small>A0013956</small> | Failure A device error has occurred. The measured value is no longer valid. |
| C <small>A0013959</small> | Function check The device is in service mode (e.g. during a simulation). |
| S <small>A0013958</small> | Out of specification The device is operated: <ul style="list-style-type: none"> ■ Outside its technical specification limits (e.g. outside the process temperature range) ■ Outside of the configuration carried out by the user (e.g. maximum flow in parameter 20 mA value) |
| M <small>A0013957</small> | Maintenance required Maintenance is required. The measured value is still valid. |

- i** The status signals are categorized according to VDI/VDE 2650 and NAMUR Recommendation NE 107: F = Failure, C = Function Check, S = Out of Specification, M = Maintenance Required

Diagnostic behavior



| Symbol | Meaning |
|--|--|
|  <small>A0013961</small> | Alarm <ul style="list-style-type: none"> ■ Measurement is interrupted. ■ Signal outputs and totalizers assume the defined alarm condition. ■ A diagnostic message is generated. ■ For local display with touch control: the background lighting changes to red. |
|  <small>A0013962</small> | Warning Measurement is resumed. The signal outputs and totalizers are not affected. A diagnostic message is generated. |

Diagnostic information

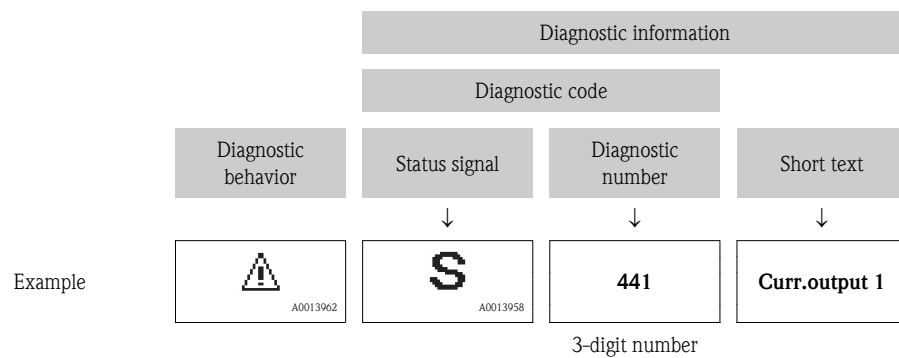
The fault can be identified using the diagnostic information. The short text helps you by providing information about the fault. In addition, the corresponding symbol for the diagnostic behavior is displayed in front of the diagnostic information on the local display.



Operating elements

| Key | Meaning |
|--|---|
|  <small>A0013970</small> | Plus key <i>In a menu, submenu</i> Opens the message about the remedy information. |
|  <small>A0013952</small> | Enter key <i>In a menu, submenu</i> Opens the operating menu. |

12.2.2 Calling up remedy information

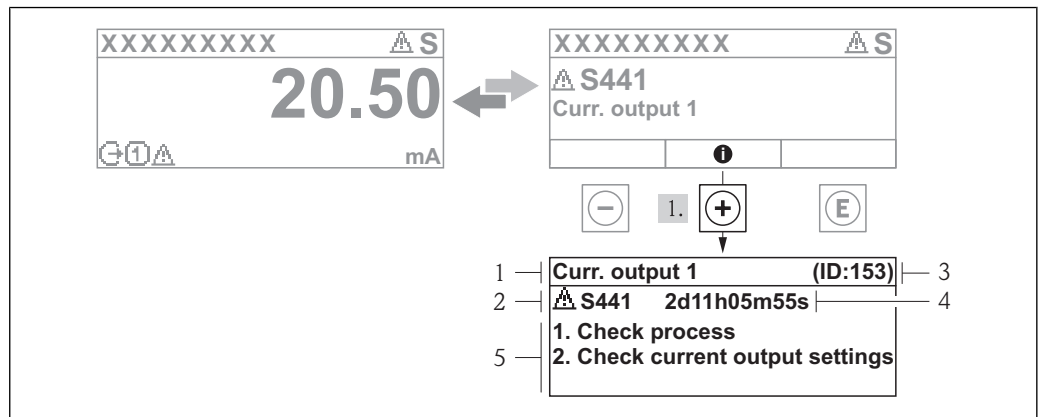

A0013940-EN

27 Message for remedial measures

- 1 Short text
- 2 Diagnostic behavior with diagnostic code
- 3 Service ID
- 4 Operation time of occurrence
- 5 Remedial measures

The user is in the diagnostic message.

1. Press **+** (**i** symbol).
 - ✓ The message for the remedial measures for the diagnostic event opens.
2. Press **-** + **+** simultaneously.
 - ✓ The message about the remedial measures closes.

The user is in the **Diagnostics** menu at an entry for a diagnostics event, e.g. in the **Diagnostic list** submenu or the **Previous diagnostics** parameter.

1. Press **E**.
 - ✓ The message for the remedy information for the selected diagnostic event opens.
2. Press **-** + **+** simultaneously.
 - ✓ The message about the remedy information closes.

12.3 Diagnostic information in FieldCare

12.3.1 Diagnostic options

Any faults detected by the measuring device are displayed on the home page of the operating tool once the connection has been established.

1 Status area with status signal

2 Diagnostic information (→ 90)

3 Remedy information with Service ID

- i** Furthermore, diagnostic events that have occurred can be viewed in the **Diagnostics** menu:
- Via parameters (→ 96)
 - Via submenu (→ 96)

12.3.2 Calling up remedy information

Remedy information is provided for every diagnostic event to ensure that problems can be rectified quickly:

- On the home page
Remedy information is displayed in a separate field below the diagnostics information.
- In the **Diagnostics** menu
Remedy information can be called up in the working area of the user interface.

The user is in the **Diagnostics** menu.

1. Call up the desired parameter.
2. On the right in the working area, mouse over the parameter.
 - ✓ A tool tip with remedy information for the diagnostic event appears.

12.4 Adapting the diagnostic information

12.4.1 Adapting the diagnostic behavior

Each diagnostic number is assigned a specific diagnostic behavior at the factory. The user can change this assignment for specific diagnostic numbers via the **Diagnostics No. xxx** parameter.

Navigation path

"Expert" menu → System → Diagnostic handling → Diagnostic behavior → Assign behavior of diagnostic no. xxx

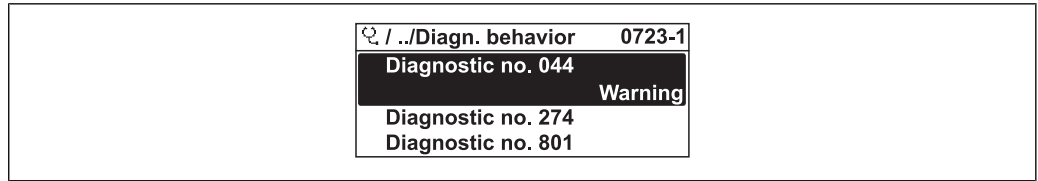

A0014048-EN

28 Illustrated using the example of the local display

You can assign the following options to the diagnostic number as the diagnostic behavior:

| Options | Description |
|--------------------|---|
| Alarm | Measurement is interrupted. Signal outputs and totalizers assume the defined alarm condition. A diagnostic message is generated. For local display with touch control: the background lighting changes to red. |
| Warning | Measurement is resumed. The signal outputs and totalizers are not affected. A diagnostic message is generated. |
| Logbook entry only | The device continues to measure. The diagnostic message is entered in the Event logbook (events list) submenu only and is not displayed in alternation with the measured value display. |
| Off | The diagnostic event is ignored, and no diagnostic message is generated or entered. |

12.5 Overview of diagnostic information

| Diagnostic number | Short text | Remedy information | Status signal from the factory | Diagnostic behavior from the factory |
|-----------------------------------|----------------|---|--------------------------------|--------------------------------------|
| Diagnostics for the sensor | | | | |
| 004 | Sensor | 1. Check transducer 1 to 4. 2. Change transducer. | F | Alarm |
| 082 | Data storage | 1. Change main electronic module. 2. Change sensor. | F | Alarm |
| 083 | Memory content | 1. Restart device. 2. Restore data. 3. Change sensor. | F | Alarm |

* Diagnostic behavior can be changed: "Adapting the diagnostic behavior" section (→ 92)

| Diagnostic number | Short text | Remedy information | Status signal from the factory | Diagnostic behavior from the factory |
|--|-----------------------|---|--------------------------------|--------------------------------------|
| Diagnostics for the electronics | | | | |
| 222 | Electronic drift | 1. Restart device. 2. Change main electronic module | F | Alarm |
| 242 | Software incompatible | 1. Check software. 2. Flash or change main electronic module. | F | Alarm |
| 252 | Modules incompatible | 1. Check electronic modules. 2. Change I/O or main electronics module. | F | Alarm |

| | | | | |
|-----|-------------------------|---|---|---------|
| 261 | Electronic modules | 1. Restart device. 2. Check electronic modules. 3. Change I/O module or main electronics. | F | Alarm |
| 262 | Module connection | 1. Check module connections. 2. Change electronic modules. | F | Alarm |
| 270 | Main electronic failure | Change main electronic module. | F | Alarm |
| 271 | Main electronic failure | 1. Restart device. 2. Change main electronic module. | F | Alarm |
| 272 | Main electronic failure | 1. Restart device. 2. Contact service. | F | Alarm |
| 273 | Main electronic failure | 1. Emergency operation via display. 2. Change main electronics. | F | Alarm |
| 275 | I/O module failure | Change I/O module. | F | Alarm |
| 276 | I/O module failure | 1. Restart device. 2. Change I/O module. | F | Alarm |
| 282 | Data storage | 1. Restart device. 2. Contact service. | F | Alarm |
| 283 | Memory content | 1. Transfer data or reset device. 2. Contact service. | F | Alarm |
| 311 | Electronic failure | 1. Transfer data or reset device. 2. Contact service. | F | Alarm |
| 311 | Electronic failure | Maintenance required! 1. Do not perform reset. 2. Contact service. | M | Warning |

* Diagnostic behavior can be changed: "Adapting the diagnostic behavior" section (→  92)

| Diagnostic number | Short text | Remedy information | Status signal from the factory | Diagnostic behavior from the factory |
|--|----------------------------|---|--------------------------------|--------------------------------------|
| Diagnostics for the configuration | | | | |
| 410 | Data transfer | 1. Check connection. 2. Retry data transfer. | F | Alarm |
| 411 | Up-/download active | Up-/download active, please wait | C | Warning |
| 431 | Trim | Carry out trim. | C | Warning |
| 437 | Incompatible configuration | 1. Restart device. 2. Contact service. | F | Alarm |
| 438 | Dataset | 1. Check data set file. 2. Check device configuration. 3. Up- and download new configuration. | M | Warning |
| 441 | Current output | 1. Check process. 2. Check current output settings. | S | Warning* |
| 442 | Frequency output 1 | 1. Check process. 2. Check frequency output setting. | S | Warning* |

| | | | | |
|-----|-----------------------------|---|---|----------|
| 443 | Pulse output 1 | 1. Check process. 2. Check pulse output setting. | S | Warning* |
| 453 | Flow override | Deactivate flow override. | C | Warning |
| 484 | Simulation failsafe mode | Deactivate simulation. | C | Alarm |
| 485 | Simulation process variable | Deactivate simulation. | C | Warning |
| 491 | Simulation current output | Deactivate simulation. | C | Warning |
| 492 | Frequency simulation 1 | Switch off frequency output simulation. | C | Warning |
| 493 | Pulse simulation 1 | Switch off pulse output simulation. | C | Warning |
| 494 | Switch output simulation 1 | Switch off switch output simulation. | C | Warning |
| 531 | Empty pipe detection | Perform empty pipe detection adjustment. | S | Warning* |

* Diagnostic behavior can be changed: "Adapting the diagnostic behavior" section (→  92)

| Diagnostic number | Short text | Remedy information | Status signal from the factory | Diagnostic behavior from the factory |
|------------------------------------|---------------------------|--|--------------------------------|--------------------------------------|
| Diagnostics for the process | | | | |
| 801 | Supply voltage too low | Increase supply voltage. | S | Warning* |
| 803 | Current loop 1-2 | 1. Check wiring. 2. Change I/O module. | F | Warning |
| 832 | Ambient temperature range | Reduce ambient temperature. | S | Warning* |
| 833 | Ambient temperature range | Increase ambient temperature. | S | Warning* |
| 842 | Process limit | Low flow cut off active! 1. Check low flow cut off configuration. | S | Logbook entry only |
| 861 | Process fluid | Check process conditions. | F | Alarm* |
| 862 | Empty pipe | 1. Check for gas in process. 2. Adjust detection limits. | S | Warning |
| 901 | Supply voltage too low | Increase supply voltage. | F | Alarm |
| 937 | EMC interference | Change main electronic module. | S | Warning |

* Diagnostic behavior can be changed: "Adapting the diagnostic behavior" section (→  92)

12.6 Pending diagnostic events



The **Diagnostics** menu allows the user to view the current diagnostic event and the previous diagnostic event separately.

Navigation path

- "Diagnostics" menu → Actual diagnostics
- "Diagnostics" menu → Previous diagnostics

Parameter overview with brief description

| Parameter | Prerequisite | Description | Display |
|----------------------|---|--|---|
| Actual diagnostics | 1 diagnostic event has occurred | Displays the current diagnostic event along with the diagnostic information.  If two or more messages occur simultaneously, the message with the highest priority is shown on the display. | Symbol for diagnostic behavior, diagnostic code and short message |
| Previous diagnostics | 2 diagnostic events have already occurred | Displays the diagnostic event that occurred prior to the current diagnostic event along with the diagnostic information. | Symbol for diagnostic behavior, diagnostic code and short message |

-  To call up the measures to rectify a diagnostic event:
- Via local display (→  91)
 - Via "FieldCare" operating tool (→  92)

-  Other diagnostic events that are pending can be viewed in the **Diagnostic list** submenu (→  96)

12.7 Diagnostic list



In the **Diagnostic list** submenu, up to 5 currently pending diagnostic events can be displayed along with the related diagnostic information. If more than 5 diagnostic events are pending, the events with the highest priority are shown on the display.

Navigation path

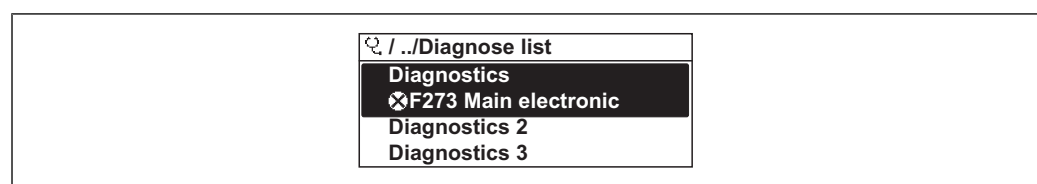
"Diagnostics" menu → Diagnostic list



 29 Illustrated using the example of the local display

-  To call up the measures to rectify a diagnostic event:
- Via local display (→  91)
 - Via "FieldCare" operating tool (→  92)

12.8 Event logbook

12.8.1 Event history

A chronological overview of the event messages that have occurred is provided in the **Events list** submenu.

Navigation path

"Diagnostics" menu → Event logbook → Events list

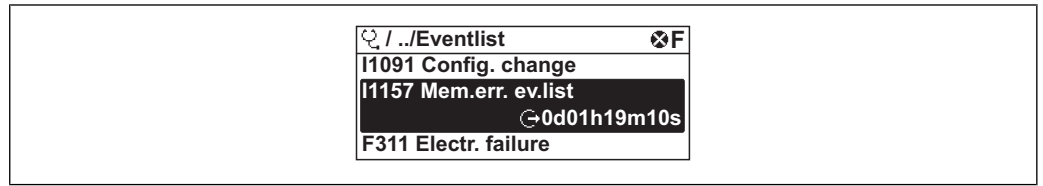

A0014008-EN

30 Illustrated using the example of the local display

A maximum of 20 event messages can be displayed in chronological order. If the advanced HistoROM function is enabled in the device (order option), up to 100 entries can be displayed.

The event history includes entries for:

- Diagnostic events (→ 93)
- Information events (→ 97)

In addition to the operation time of its occurrence, each event is also assigned a symbol that indicates whether the event has occurred or is ended:

- Diagnostics event
 - ⌚: Event has occurred
 - ⌚: Event has ended
- Information event
 - ⌚: Event has occurred

i To call up the measures to rectify a diagnostic event:

- Via local display (→ 91)
- Via "FieldCare" operating tool (→ 92)

i For filtering the displayed event messages (→ 97)

12.8.2 Filtering the event logbook

Using the **Filter options** parameter, you can define which category of event messages is displayed in the **Events list** submenu.

Navigation path

"Diagnostics" menu → Event logbook → Filter options

Filter categories

- All
- Failure (F)
- Function check (C)
- Out of specification (S)
- Maintenance required (M)
- Information (I)

12.8.3 Overview of information events

Unlike a diagnostic event, an information event is displayed in the event logbook only and not in the diagnostic list.

| Information event | Event text |
|-------------------|----------------|
| I1000 | —— (device ok) |
| I1079 | Sensor changed |
| I1089 | Power on |

| | |
|-------|---|
| I1090 | Configuration reset |
| I1091 | Configuration changed |
| I1092 | Trend data deleted |
| I1110 | Write protection switch changed |
| I1137 | Electronic changed |
| I1151 | History reset |
| I1154 | Reset terminal voltage min/max |
| I1155 | Reset electronic temperature |
| I1156 | Memory error trend |
| I1157 | Memory error event list |
| I1185 | Display backup done |
| I1186 | Restore via display done |
| I1187 | Settings downloaded with display |
| I1188 | Display data cleared |
| I1189 | Backup compared |
| I1227 | Sensor emergency mode activated |
| I1228 | Sensor emergency mode failed |
| I1256 | Display: access status modified |
| I1335 | Firmware changed |
| I1351 | Empty pipe detection adjustment failure |
| I1353 | Empty pipe detection adjustment Ok |
| I1397 | Fieldbus: access status modified |
| I1398 | CDI: access status modified |

12.9 Resetting the measuring device

Using the **Device reset** parameter it is possible to reset the entire device configuration or some of the configuration to a defined state.

Navigation path

"Diagnostics" menu → Device reset → Device reset

Function scope of the "Device reset" parameter

| Options | Description |
|---------------------|--|
| Cancel | The user exits the parameter and no action is performed. |
| To factory defaults | Every parameter is reset to its factory setting. |

| Options | Description |
|----------------------|--|
| To delivery settings | Every parameter for which a customized default setting was ordered is reset to that customized value; all other parameters are reset to their factory setting.  This option is not visible if no customized settings were ordered. |
| Restart device | Restarting the device resets every parameter whose data are saved in the volatile memory (RAM) to the parameter's factory setting (e.g. measured value data). The device configuration remains unchanged. |

12.10 Device information

The **Device information** submenu contains all the parameters that display different information for identifying the device.

Navigation path

"Diagnostics" menu → Device information

Structure of the submenu

Device info →

Device tag

(→  70)

Serial number

Firmware version

Device name

Order code

Extended order code 1

Extended order code 2

Extended order code 3

ENP version

Device revision



Device ID

Device type

Manufacturer ID

Parameter overview with brief description

| Parameter | Prerequisite | Description | Display |
|---------------|--------------|--|---|
| Serial number | - | Displays the serial number of the measuring device.  The number can be found on the nameplate of the sensor and transmitter. | Max. 11-digit character string comprising letters and numbers |

| | | | |
|-------------------------|---|---|---|
| Firmware version | - | Displays the device firmware version installed. | Character string in the format xx.yy.zz |
| Device name | - | Displays the name of the transmitter.  The name can be found on the nameplate of the transmitter. | |
| Order code | - | Displays the device order code.  The order code can be found on the nameplate of the sensor and transmitter in the "Order code" field. | Character string composed of letters, numbers and certain punctuation marks |
| Extended order code 1-3 | Depending on the length of the extended order code, the code is divided into a maximum of 3 parameters. | Displays the 1st, 2nd or 3rd part of the extended order code.  The extended order code can also be found on the nameplate of the sensor and transmitter in the "Ext. ord. cd." field. | Character string |
| ENP version | - | Displays the version of the electronic nameplate. | Character string in the format xx.yy.zz |
| Device revision | - | Displays the device revision with which the device is registered with the HART Communication Foundation. | 2-digit hexadecimal number |
| Device ID | - | Displays the device ID for identifying the device in a HART network. | 6-digit hexadecimal number |
| Device type | - | Displays the device type with which the measuring device is registered with the HART Communication Foundation. | |
| Manufacturer ID | - | Displays the manufacturer ID with which the measuring device is registered with the HART Communication Foundation. | 0x11 (for Endress+Hauser) |

12.11 Disposal

12.11.1 Removing the measuring device

1. Switch off the device.
2. **WARNING!** Danger to persons from process conditions. Beware of hazardous process conditions such as pressure in the measuring device, high temperatures or aggressive fluids. Carry out the mounting and connection steps from the chapters "Mounting the measuring device" and "Connecting the measuring device" in the logically reverse sequence. Observe the safety instructions.

12.11.2 Disposing of the measuring device

⚠ WARNING

Danger to personnel and environment from fluids that are hazardous to health.

- ▶ Ensure that the measuring device and all cavities are free of fluid residues that are hazardous to health or the environment, e.g. substances that have permeated into crevices or diffused through plastic.

Observe the following notes during disposal:

- Observe valid federal/national regulations.
- Ensure proper separation and reuse of the device components.

13 Repair

13.1 General notes

Repair and conversion concept

The Endress+Hauser repair and conversion concept provides for the following:

- The measuring devices have a modular design.
- Spare parts are grouped into logical kits with the associated Installation Instructions.
- Repairs are carried out by Endress+Hauser Service or by correspondingly trained customers.
- Certified devices can be converted into other certified devices by Endress+Hauser Service or at the factory only.

Notes for repair and conversion

For repair and modification of a measuring device, observe the following notes:

- Use only original Endress+Hauser spare parts.
- Carry out the repair according to the Installation Instructions.
- Observe the applicable standards, federal/national regulations, Ex documentation (XA) and certificates.
- Document every repair and each conversion and enter them into the *W@M* life cycle management database.

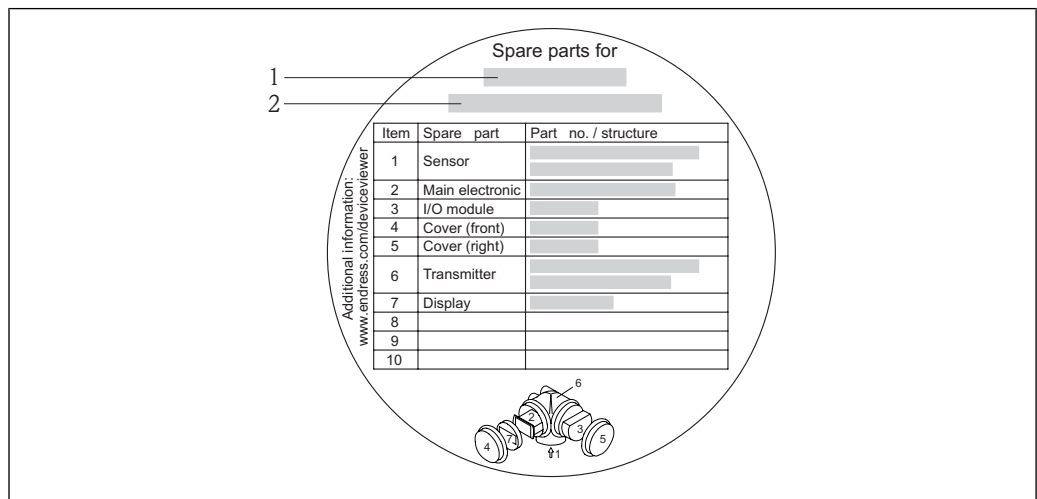

13.2 Spare parts

- Some interchangeable measuring device components are listed on an overview sign in the connection compartment cover.
- This sign with an overview of the spare parts is located in the connection compartment cover of the device and contains the following information:
 - A list of the most important spare parts for the measuring device, including their ordering information.
 - The URL for the *W@M Device Viewer* (www.endress.com/deviceviewer):
All the spare parts for the measuring device, along with the order code, are listed here and can be ordered. If available, users can also download the associated Installation Instructions.



31 Example for "Spare part overview sign" in connection compartment cover

- 1 Measuring device name
- 2 Measuring device serial number

-  Measuring device serial number:
 - Is located on the device nameplate and the spare part overview sign.
 - Can be read out via the **Serial number** parameter in the **Device information** submenu (→  99).

13.3 Endress+Hauser services

-  Contact your Endress+Hauser Sales Center for information on services and spare parts.

14 Maintenance

14.1 Maintenance tasks

No special maintenance work is required.

14.1.1 Exterior cleaning

When cleaning the exterior of measuring devices, always use cleaning agents that do not attack the surface of the housing or the seals.

14.1.2 Interior cleaning

No interior cleaning is planned for the device.

14.2 Measuring and test equipment

Endress+Hauser offers a wide variety of measuring and test equipment, such as W@M or device tests.

 Your Endress+Hauser Sales Center can provide detailed information on the services.

 For a list of some of the measuring and test equipment, refer to the "Accessories" chapter of the "Technical Information" document for the device.

14.3 Endress+Hauser services

Endress+Hauser offers a wide variety of services for maintenance such as recalibration, maintenance service or device tests.

 Your Endress+Hauser Sales Center can provide detailed information on the services.

15 Return

The measuring device must be returned if repairs or a factory calibration are required, or if the wrong measuring device has been ordered or delivered. According to legal regulations, Endress+Hauser, as an ISO-certified company, is required to follow certain procedures when handling returned products that are in contact with medium.

To ensure swift, safe and professional device returns, please read the return procedures and conditions on the Endress+Hauser website at www.services.endress.com/return-material

16 Technical data

16.1 Application

The measuring device is only suitable for flow measurement of liquids with a minimum conductivity of 20 $\mu\text{S}/\text{cm}$.

Depending on the version ordered, the measuring device can also measure potentially explosive, flammable, poisonous and oxidizing media.

To ensure that the device remains in proper operating condition for its service life, use the measuring device only for media against which the process-wetted materials are adequately resistant.

16.2 Function and system design

Measuring principle Electromagnetic flow measurement on the basis of *Faraday's law of magnetic induction*.

Measuring system The device consists of a transmitter and a sensor.
One device version is available: compact version, transmitter and sensor form a mechanical unit.
For information on the structure of the device (\rightarrow  10)

16.3 Input

Measured variable **Direct measured variables**
Volume flow (proportional to induced voltage)

Calculated measured variables
Mass flow

Measuring range Typically $v = 0.01$ to 10 m/s (0.03 to 33 ft/s) with the specified accuracy

Flow characteristic values in SI units

| Nominal diameter | | Recommended flow min./max. full scale value ($v \sim 0.310$ m/s/ [dm ³ /min]) | Factory settings | | |
|------------------|------|--|--|--|--|
| [mm] | [in] | | Full scale value current output ($v \sim 2.5$ m/s) [dm ³ /min] | Pulse value (~ 2 pulse/s) [dm ³] | Low flow cut off ($v \sim 0.04$ m/s) [dm ³ /min] |
| 15 | ½ | 4 to 100 | 25 | 0.2 | 0.5 |
| 25 | 1 | 9 to 300 | 75 | 0.5 | 1 |
| 32 | – | 15 to 500 | 125 | 1 | 2 |
| 40 | 1 ½ | 25 to 700 | 200 | 1.5 | 3 |
| 50 | 2 | 35 to 1100 | 300 | 2.5 | 5 |
| 65 | – | 60 to 2000 | 500 | 5 | 8 |
| 80 | 3 | 90 to 3000 | 750 | 5 | 12 |
| 100 | 4 | 145 to 4700 | 1200 | 10 | 20 |
| 125 | – | 220 to 7500 | 1850 | 15 | 30 |

| Nominal diameter | | Recommended flow min./max. full scale value (v ~ 0.310 m/s/ [dm ³ /min]) | Factory settings | | |
|------------------|------|--|--|--|--|
| [mm] | [in] | | Full scale value current output (v ~ 2.5 m/s) [dm ³ /min] | Pulse value (~ 2 pulse/s) [dm ³] | Low flow cut off (v ~ 0.04 m/s) [dm ³ /min] |
| 150 | 6 | 20 to 600 m ³ /h | 150 m ³ /h | 0.03 m ³ | 2.5 m ³ /h |
| 200 | 8 | 35 to 1 100 m ³ /h | 300 m ³ /h | 0.05 m ³ | 5 m ³ /h |

Flow characteristic values in US units

| Nominal diameter | | Recommended flow min./max. full scale value (v ~ 0.3/10 m/s [gal/min]) | Factory settings | | |
|------------------|------|---|---|---------------------------------------|---|
| [in] | [mm] | | Full scale value current output (v ~ 2.5 m/s) [gal/min] | Pulse value (~ 2 pulse/s) [gal] | Low flow cut off (v ~ 0.04 m/s) [gal/min] |
| ½ | 15 | 1.0 to 27 | 6 | 0.05 | 0.10 |
| 1 | 25 | 2.5 to 80 | 18 | 0.2 | 0.25 |
| – | 32 | 4 to 130 | 30 | 0.2 | 0.5 |
| 1 ½ | 40 | 7 to 190 | 50 | 0.5 | 0.75 |
| 2 | 50 | 10 to 300 | 75 | 0.5 | 1.25 |
| – | 65 | 16 to 500 | 130 | 1 | 2 |
| 3 | 80 | 24 to 800 | 200 | 2 | 2.5 |
| 4 | 100 | 40 to 1 250 | 300 | 2 | 4 |
| – | 125 | 60 to 1 950 | 450 | 5 | 7 |
| 6 | 150 | 90 to 2 650 | 600 | 5 | 12 |
| 8 | 200 | 155 to 4 850 | 1 200 | 10 | 15 |

Recommended measuring range

"Flow limit" section (→  116)

Operable flow range Over 1000 : 1

16.4 Output

Output signal

Current output

| | |
|-------------------------------|--|
| Current output | 4-20 mA HART (passive) |
| Resolution | < 1 µA |
| Damping | Adjustable:0.0 to 999 s |
| Assignable measured variables | <ul style="list-style-type: none"> ■ Volume flow ■ Mass flow |

Pulse/frequency/switch output

| | |
|--------------------------------------|--|
| Function | Can be set to pulse, frequency or switch output |
| Version | Passive, open collector |
| Maximum input values | <ul style="list-style-type: none"> ■ DC 35 V ■ 50 mA  For information on the Ex connection values |
| Voltage drop | <ul style="list-style-type: none"> ■ For ≤ 2 mA: 2 V ■ For 10 mA: 8 V |
| Residual current | ≤ 0.05 mA |
| Pulse output | |
| Pulse width | Adjustable:5 to 2 000 ms |
| Maximum pulse rate | 100 Impulse/s |
| Pulse value | Adjustable |
| Assignable measured variables | <ul style="list-style-type: none"> ■ Volume flow ■ Mass flow |
| Frequency output | |
| Output frequency | Adjustable:0 to 1 000 Hz |
| Damping | Adjustable:0 to 999 s |
| Pulse/pause ratio | 1:1 |
| Assignable measured variables | <ul style="list-style-type: none"> ■ Volume flow ■ Mass flow |
| Switch output | |
| Switching behavior | Binary, conductive or non-conductive |
| Switching delay | Adjustable:0 to 100 s |
| Number of switching cycles | Unlimited |
| Assignable functions | <ul style="list-style-type: none"> ■ Off ■ On ■ Diagnostic behavior ■ Limit value <ul style="list-style-type: none"> – Volume flow – Mass flow ■ Flow direction monitoring ■ Status <ul style="list-style-type: none"> – Empty pipe detection – Low flow cut off |

Signal on alarm

Depending on the interface, failure information is displayed as follows:

Current output

4-20 mA

| | |
|---------------------|--|
| Failure mode | Selectable (as per NAMUR recommendation NE 43): <ul style="list-style-type: none"> ■ Minimum value: 3.6 mA ■ Maximum value: 22 mA ■ Defined value:3.59 to 22.5 mA ■ Actual value ■ Last valid value |
|---------------------|--|

HART

| | |
|---------------------------|--|
| Device diagnostics | Device condition can be read out via HART Command 48 |
|---------------------------|--|

Pulse/frequency/switch output

| Pulse output | |
|-------------------------|--|
| Failure mode | Choose from: <ul style="list-style-type: none"> ■ Actual value ■ No pulses |
| Frequency output | |
| Failure mode | Choose from: <ul style="list-style-type: none"> ■ Actual value ■ Defined value:0 to 1 250 Hz ■ 0 Hz |
| Switch output | |
| Failure mode | Choose from: <ul style="list-style-type: none"> ■ Current status ■ Open ■ Closed |

Local display

| | |
|---------------------------|---|
| Plain text display | With information on cause and remedial measures |
| Backlight | Additionally for device version with SD03 local display: red lighting indicates a device error. |

 Status signal as per NAMUR recommendation NE 107

Operating tool

- Via digital communication: HART protocol
- Via service interface

| | |
|---------------------------|---|
| Plain text display | With information on cause and remedial measures |
|---------------------------|---|



Load (→  27)

Low flow cut off The switch points for low flow cut off are user-selectable.

Galvanic isolation All outputs are galvanically isolated from one another.

Protocol-specific data

HART

- For information on the device description files (→  51)
- For information on the dynamic variables and measured variables (HART device variables) (→  51)

16.5 Power supply

Terminal assignment (→ [27](#))

Supply voltage An external power supply is required for each output. The following supply voltage values apply for the 4-20 mA HART current output:

| Order code for "Output" | Minimum terminal voltage ^{1) 2)} | Maximum terminal voltage |
|---|---|--------------------------|
| <ul style="list-style-type: none"> ■ Option A: 4-20 mA HART ■ Option B: 4-20 mA HART, pulse/frequency/switch output | For 4 mA: ≥ DC18 V For 20 mA: ≥ DC14 V | DC 35 V |

1) External supply voltage of the power supply unit with load (→ [27](#))

2) For device versions with local display SD03: The terminal voltage must be increased by DC 2 V if backlighting is used.

Power consumption

Transmitter

| Order code for "Power supply" | Maximum power consumption |
|---|---|
| Option A: 4-20 mA HART | 770 mW |
| Option B: 4-20 mA HART, pulse/frequency/switch output | <ul style="list-style-type: none"> ■ Operation with output 1:770 mW ■ Operation with output 1 and 2:2770 mW |

Current consumption

For 4-20 mA or 4-20 mA HART current output: 3.6 to 22.5 mA

 If the option **Defined value** is selected in the **Failure mode** parameter (→ [108](#)): 3.59 to 22.5 mA

Power supply failure

- Totalizers stop at the last value measured.
- Configuration is retained in the device memory (HistoROM).
- Error messages (incl. total operated hours) are stored.

Electrical connection (→ [28](#))

Potential equalization (→ [30](#))

Terminals

- For device version without integrated overvoltage protection: plug-in spring terminals for wire cross-sections 0.5 to 2.5 mm² (20 to 14 AWG)
- For device version with integrated overvoltage protection: screw terminals for wire cross-sections 0.2 to 2.5 mm² (24 to 14 AWG)

Cable entries

- Cable gland: M20 × 1.5 with cable Ø 6 to 12 mm (0.24 to 0.47 in)
- Thread for cable entry:
 - NPT ½"
 - G ½"

Cable specification (→ [26](#))

Overvoltage protection

The device can be ordered with integrated overvoltage protection for several approvals:
Order code for "Accessory mounted", option **NA** "overvoltage protection"

| | |
|--|---|
| Input voltage range | Values correspond to supply voltage specifications (→ 27) ¹⁾ |
| Resistance per channel | 2 · 0.5 Ω max |
| DC sparkover voltage | 400 to 700 V |
| Trip surge voltage | < 800 V |
| Capacitance at 1 MHz | < 1.5 pF |
| Nominal discharge current (8/20 μs) | 10 kA |
| Temperature range | -40 to +85 °C (-40 to +185 °F) |

1) The voltage is reduced by the amount of the internal resistance $I_{\min} \cdot R_i$

 Depending on the temperature class, restrictions apply to the ambient temperature for device versions with overvoltage protection .

16.6 Performance characteristics

Reference operating conditions

To DIN EN 29104

- Fluid temperature: $+28 \pm 2$ °C ($+82 \pm 4$ °F)
- Ambient temperature range: $+22 \pm 2$ °C ($+72 \pm 4$ °F)
- Warm-up period: 30 min

Installation

- Inlet run $> 10 \times DN$
- Outlet run $> 5 \times DN$
- Sensor and transmitter grounded.
- The sensor is centered in the pipe.

Maximum measured error

Accuracy of outputs

o.r. = of reading; o.f.s. = of full scale value

Current output

| | |
|-----------------|----------------|
| Accuracy | $\pm 10 \mu A$ |
|-----------------|----------------|

Pulse/frequency output

| | |
|-----------------|-------------------------|
| Accuracy | Max. ± 100 ppm o.r. |
|-----------------|-------------------------|

Error limits under reference operating conditions

o.r. = of reading

Pulse output

± 0.5 % o.r. ± 2 mm/s (0.08 in/s)

 Fluctuations in the supply voltage do not have any effect within the specified range.

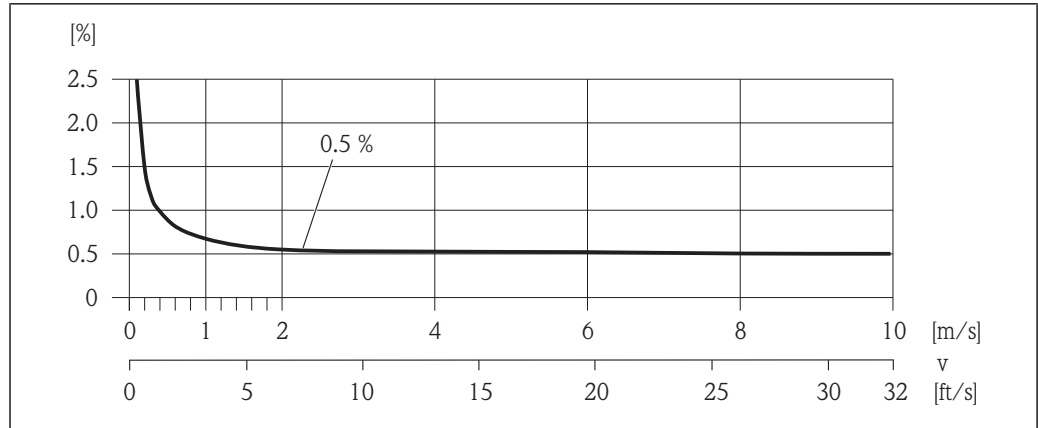

32 Maximum measured error in % o.r.

Repeatability o.r. = of reading
 max. ±0.2 % o.r. ±2 mm/s (0.08 in/s)

Influence of ambient temperature o.r. = of reading; o.f.s. = of full scale value

Current output

Additional error, in relation to the span of 16 mA:

| | |
|---|--|
| Temperature coefficient at zero point (4 mA) | 0.02 %/10 K, max. 0.35 % over the entire temperature range -40 to +60 °C (-40 to +140 °F) |
| Temperature coefficient with span (20 mA) | 0.05 %/10 K, max. 0.5 % over the entire temperature range -40 to +60 °C (-40 to +140 °F) |

Pulse/frequency output

| | |
|--------------------------------|--------------------|
| Temperature coefficient | Max. ±100 ppm o.r. |
|--------------------------------|--------------------|

16.7 Installation

"Mounting requirements" (→ 17)

16.8 Environment

Ambient temperature range (→ 19)

Storage temperature The storage temperature corresponds to the operating temperature range of the measuring transmitter and the appropriate measuring sensors.

- Protect the measuring device against direct sunlight during storage in order to avoid unacceptably high surface temperatures.
- Select a storage location where moisture cannot collect in the measuring device as fungus or bacteria infestation can damage the liner.
- If protection caps or protective covers are mounted these should never be removed before installing the measuring device.

| | |
|-------------------------------------|--|
| Degree of protection | <p>Transmitter</p> <ul style="list-style-type: none"> ■ As standard: IP66/67, type 4X enclosure ■ When housing is open: IP20, type 1 enclosure ■ Display module: IP22, type 1 enclosure <p>Sensor</p> <p>IP66/67, type 4X enclosure</p> |
| Shock resistance | As per IEC/EN 60068-2-31 |
| Vibration resistance | Acceleration up to 2 g following IEC 60068-2-6 |
| Mechanical load | <ul style="list-style-type: none"> ■ Protect the transmitter housing against mechanical effects, such as shock or impact. ■ Never use the transmitter housing as a ladder or climbing aid. |
| Electromagnetic compatibility (EMC) | <p>As per IEC/EN 61326 and NAMUR Recommendation 21 (NE 21)</p> <p> Details are provided in the Declaration of Conformity.</p> |

16.9 Process

| | |
|--------------------------|--|
| Medium temperature range | <ul style="list-style-type: none"> ■ -20 to +150 °C (-4 to +302 °F) for PFA ■ -40 to +130 °C (-40 to +266 °F) for PTFE |
|--------------------------|--|

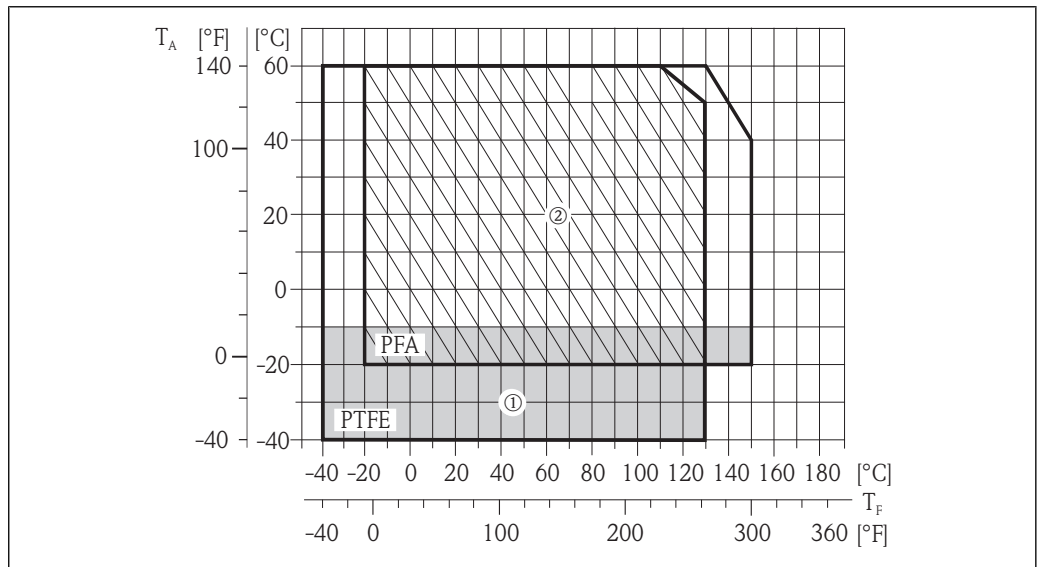

T_A Ambient temperature

T_F Medium temperature

① Area shaded in gray: the ambient temperature range of -10 to -40 °C (-14 to -40 °F) applies to stainless flanges only

② Harsh environment and IP68 only to +130 °C (+266 °F)

| | |
|--------------|-----------------------------------|
| Conductivity | ≥ 20 μS/cm for liquids in general |
|--------------|-----------------------------------|

Pressure-temperature ratings The following material load diagrams refer to the entire device and not just the process connection.

Flange connection according to EN 1092-1 (DIN 2501)

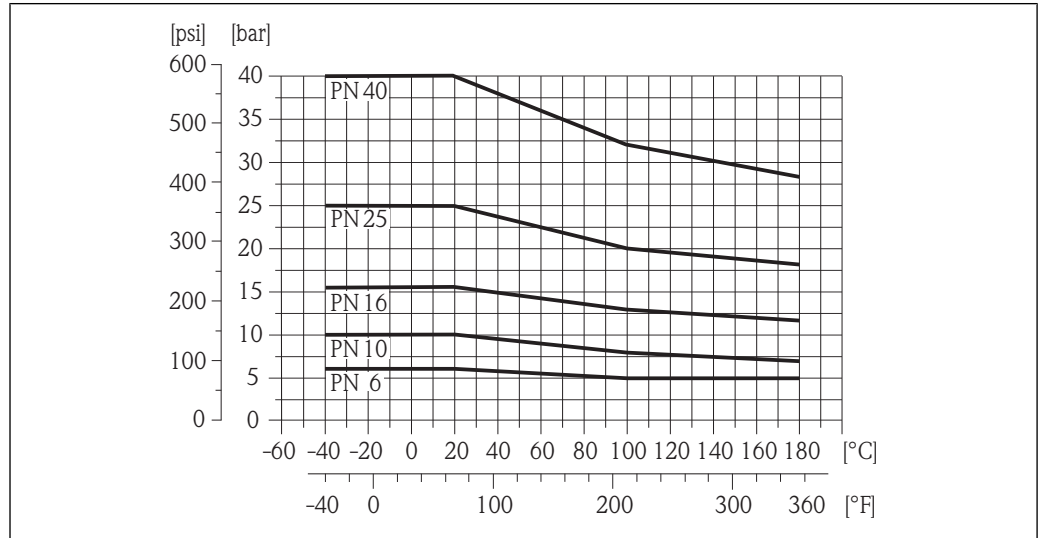

33 Materials C22, FE 410W B and S235JRG2

Flange connection according to EN 1092-1 (DIN 2501)

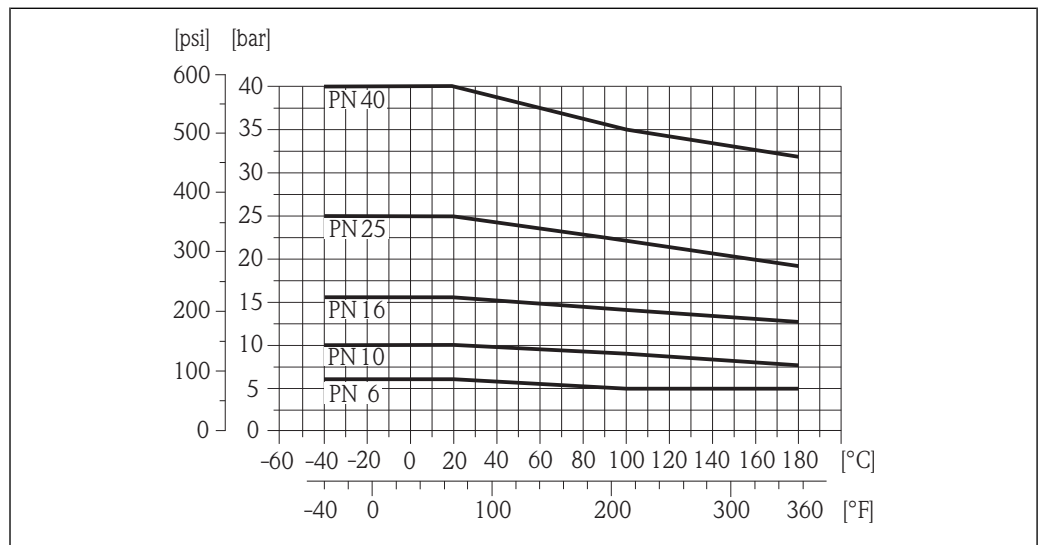

34 Material 1.4571/316L

Flange connection according to ASME B16.5

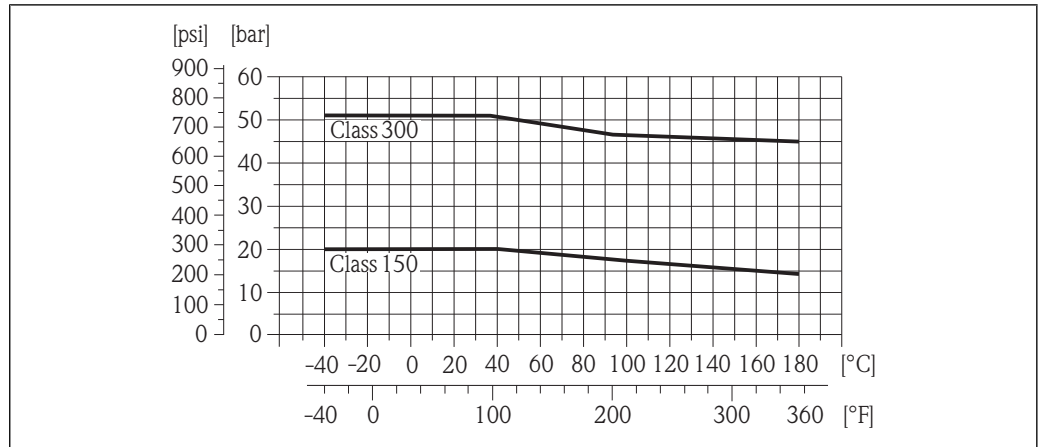

35 Material A105

Flange connection according to ASME B16.5

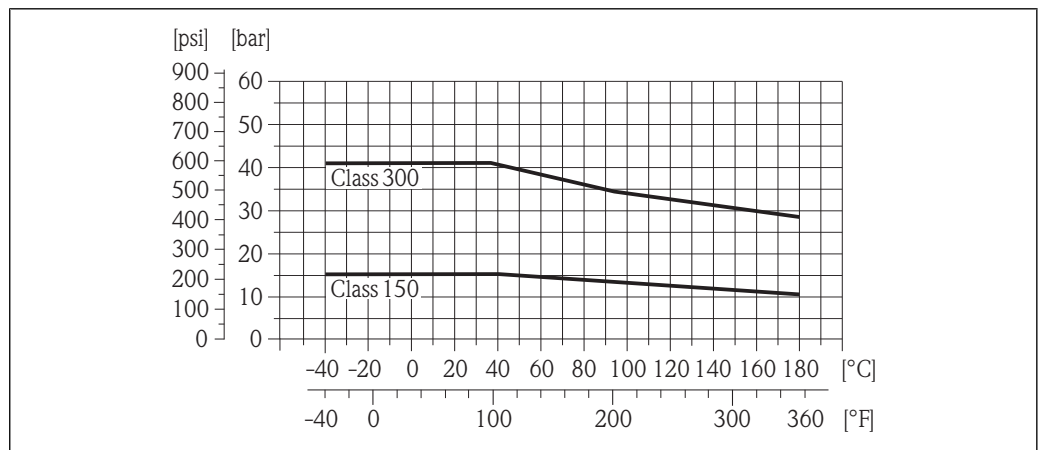

36 Material F316L

Flange connection according to JIS B2220

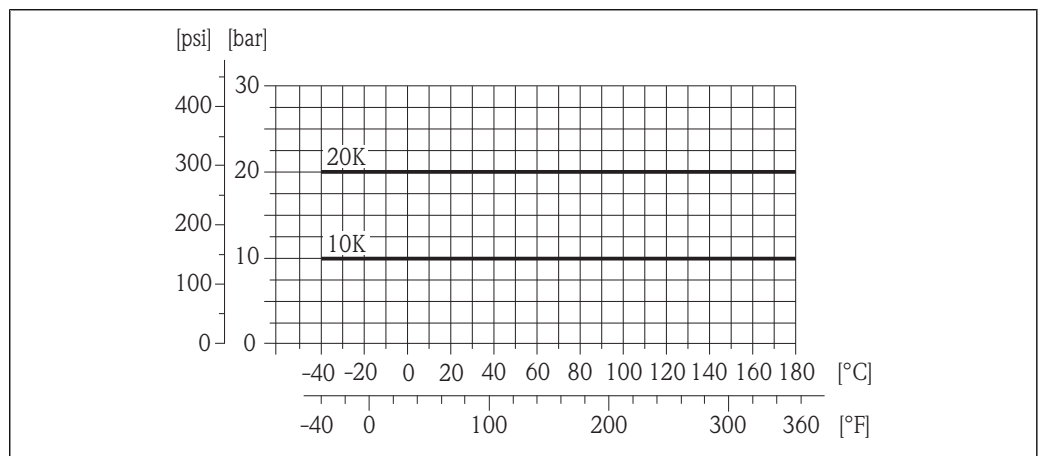

37 Materials 1.0425/316L, HII, S235JRG2

Pressure-temperature ratings



An overview of the material load diagrams (pressure/temperature diagrams) for the process connections is provided in the "Technical Information" document.

Pressure tightness

Liner: PFA

| Nominal diameter | | Limit values for absolute pressure in [mbar] ([psi]) for fluid temperatures: | | |
|------------------|------|--|------------------|-----------------------------------|
| [mm] | [in] | +25 °C (+77 °F) | +80 °C (+176 °F) | +100 to +180 °C (+212 to +356 °F) |
| 25 | 1 | 0 (0) | 0 (0) | 0 (0) |
| 32 | – | 0 (0) | 0 (0) | 0 (0) |
| 40 | 1 ½ | 0 (0) | 0 (0) | 0 (0) |
| 50 | 2 | 0 (0) | 0 (0) | 0 (0) |
| 65 | – | 0 (0) | – (–) | 0 (0) |
| 80 | 3 | 0 (0) | – (–) | 0 (0) |
| 100 | 4 | 0 (0) | – (–) | 0 (0) |
| 125 | – | 0 (0) | – (–) | 0 (0) |
| 150 | 6 | 0 (0) | – (–) | 0 (0) |
| 200 | 8 | 0 (0) | – (–) | 0 (0) |

Liner: PTFE

| Nominal diameter | | Limit values for absolute pressure in [mbar] ([psi]) for fluid temperatures: | | | |
|------------------|------|--|------------------|-------------------|-------------------|
| [mm] | [in] | +25 °C (+77 °F) | +80 °C (+176 °F) | +100 °C (+212 °F) | +130 °C (+266 °F) |
| 15 | ½ | 0 (0) | 0 (0) | 0 (0) | 100 (1.45) |
| 25 | 1 | 0 (0) | 0 (0) | 0 (0) | 100 (1.45) |
| 32 | – | 0 (0) | 0 (0) | 0 (0) | 100 (1.45) |
| 40 | 1 ½ | 0 (0) | 0 (0) | 0 (0) | 100 (1.45) |
| 50 | 2 | 0 (0) | 0 (0) | 0 (0) | 100 (1.45) |
| 65 | – | 0 (0) | – (–) | 40 (0.58) | 130 (1.89) |
| 80 | 3 | 0 (0) | – (–) | 40 (0.58) | 130 (1.89) |
| 100 | 4 | 0 (0) | – (–) | 135 (1.96) | 170 (2.47) |
| 125 | – | 135 (1.96) | – (–) | 240 (3.48) | 385 (5.58) |
| 150 | 6 | 135 (1.96) | – (–) | 240 (3.48) | 385 (5.58) |
| 200 | 8 | 200 (2.90) | – (–) | 290 (4.21) | 410 (5.95) |

Flow limit

The diameter of the pipe and the flow rate determine the nominal diameter of the sensor. The optimum velocity of flow is between 2 to 3 m/s (6.56 to 9.84 ft/s). Also match the velocity of flow (v) to the physical properties of the fluid:

- v < 2 m/s (6.56 ft/s): for abrasive fluids (e.g. potter's clay, lime milk, ore slurry)
- v > 2 m/s (6.56 ft/s): for fluids producing buildup (e.g. wastewater sludges)



For an overview of the measuring range full scale values, see the "Measuring range" section (→ 106)

Pressure loss

- No pressure loss occurs if the sensor is installed in a pipe with the same nominal diameter.
- Pressure losses for configurations incorporating adapters according to DIN EN 545 (→ 20)

System pressure

(→ 20)

Vibrations

(→ 20)

16.10 Mechanical construction

Design, dimensions



For the dimensions and installation lengths of the device, see the "Technical Information" document, "Mechanical construction" section

Weight

Compact version

Weight data:

- Including the transmitter (1.9 kg (4.2 lbs))
- Weight specifications apply to standard pressure ratings and without packaging material.

Weight in SI units

| Nominal diameter | | EN (DIN), AS ¹⁾ | | ASME | | JIS | |
|------------------|------|----------------------------|------|-----------------|------|-----------------|------|
| [mm] | [in] | Pressure rating | [kg] | Pressure rating | [kg] | Pressure rating | [kg] |
| 15 | ½ | PN 40 | 5.0 | Class 150 | 5.0 | 10K | 5.0 |
| 25 | 1 | PN 40 | 5.8 | Class 150 | 5.8 | 10K | 5.8 |
| 32 | 1 ¼ | PN 40 | 6.5 | Class 150 | – | 10K | 5.8 |
| 40 | 1 ½ | PN 40 | 7.9 | Class 150 | 7.9 | 10K | 6.8 |
| 50 | 2 | PN 40 | 9.1 | Class 150 | 9.1 | 10K | 7.8 |
| 65 | 2 ½ | PN 16 | 10.5 | Class 150 | – | 10K | 9.6 |
| 80 | 3 | PN 16 | 12.5 | Class 150 | 12.5 | 10K | 11.0 |
| 100 | 4 | PN 16 | 14.5 | Class 150 | 14.5 | 10K | 13.2 |
| 125 | 5 | PN 16 | 20.0 | Class 150 | – | 10K | 19.5 |
| 150 | 6 | PN 16 | 24.0 | Class 150 | 24.0 | 10K | 23.0 |
| 200 | 8 | PN 10 | 43.5 | Class 150 | 43.5 | 10K | 40.4 |

1) For flanges to AS, only DN 25 and 50 are available.

Weight in US units

| Nominal diameter | | ASME | |
|------------------|------|-----------------|-------|
| [mm] | [in] | Pressure rating | [lbs] |
| 15 | ½ | Class 150 | 11.0 |
| 25 | 1 | Class 150 | 12.8 |
| 32 | 1 ¼ | Class 150 | – |
| 40 | 1 ½ | Class 150 | 17.4 |
| 50 | 2 | Class 150 | 20.1 |
| 65 | 2 ½ | Class 150 | – |
| 80 | 3 | Class 150 | 27.6 |
| 100 | 4 | Class 150 | 32.0 |
| 125 | 5 | Class 150 | – |
| 150 | 6 | Class 150 | 52.9 |
| 200 | 8 | Class 150 | 95.9 |

Measuring tube specification

| Nominal diameter | | Pressure rating | | | | | Process connection internal diameter | | | |
|------------------|------|-----------------|-----------|---------|---------|-------|--------------------------------------|------|------|------|
| | | EN (DIN) | ASME | AS 2129 | AS 4087 | JIS | PFA | | PTFE | |
| [mm] | [in] | [bar] | [psi] | [bar] | [bar] | [bar] | [mm] | [in] | [mm] | [in] |
| 15 | ½ | PN 40 | Class 150 | – | – | 20K | – | – | 15 | 0.59 |
| 25 | 1 | PN 40 | Class 150 | Table E | – | 20K | 23 | 0.91 | 26 | 1.02 |
| 32 | – | PN 40 | – | – | – | 20K | 32 | 1.26 | 35 | 1.38 |
| 40 | 1 ½ | PN 40 | Class 150 | – | – | 20K | 36 | 1.42 | 41 | 1.61 |
| 50 | 2 | PN 40 | Class 150 | Table E | PN 16 | 10K | 48 | 1.89 | 52 | 2.05 |
| 65 | – | PN 16 | – | – | – | 10K | 63 | 2.48 | 67 | 2.64 |
| 80 | 3 | PN 16 | Class 150 | – | – | 10K | 75 | 2.95 | 80 | 3.15 |
| 100 | 4 | PN 16 | Class 150 | – | – | 10K | 101 | 3.98 | 104 | 4.09 |
| 125 | – | PN 16 | – | – | – | 10K | 126 | 4.96 | 129 | 5.08 |
| 150 | 6 | PN 16 | Class 150 | – | – | 10K | 154 | 6.06 | 156 | 6.14 |
| 200 | 8 | PN 10 | Class 150 | – | – | 10K | 201 | 7.91 | 202 | 7.95 |

Materials

Transmitter housing

- Order code for "Housing", option **C**: aluminum coating AlSi10Mg
- Window material: glass

Transmitter cable entries

Order code for "Housing", option C "GT20 two-chamber, aluminum coating"

| Electrical connection | Type of protection | Material |
|---------------------------|--|---------------------|
| Cable gland M20 × 1.5 | <ul style="list-style-type: none"> ■ Non-Ex ■ Ex ia ■ Ex ic | Plastic |
| | <ul style="list-style-type: none"> ■ Ex nA ■ Ex tb | Nickel-plated brass |
| Thread G ½" via adapter | For non-Ex and Ex (except for CSA Ex d/XP) | Nickel-plated brass |
| Thread NPT ½" via adapter | For non-Ex and Ex | |

Sensor housing

Aluminum coating AlSi10Mg

Measuring tubes

Stainless steel 1.4301/304 or 1.4306/304L; for flanges made of carbon steel with Al/Zn protective coating

Liner

- PFA
- PTFE

Process connections

EN 1092-1 (DIN 2501)

1.4571/316L, C22, FE 410W B, S235JRG2; with Al/Zn protective varnish

ASME B16.5

A105, F316L; with Al/Zn protective varnish

JIS

S235JRG2, HII, 1.0425/316L; with Al/Zn protective varnish

 List of all available process connections (→  119)

Electrodes

1.4435/316L, Alloy C-22, platinum, tantalum

Seals

In accordance with DIN EN 1514-1

Accessories

Weather protection cover

Stainless steel 1.4301

Ground disks

1.4435/316L, Alloy C-22, tantalum



Fitted electrodes

Measuring electrodes, reference electrodes and electrodes for empty pipe detection:

- Standard: 1.4435/316L, Alloy C-22, platinum, tantalum
- Optional: only measuring electrodes made from platinum

Process connections

- EN 1092-1 (DIN 2501); dimensions as per DIN 2501, DN 65 PN 16 only as per EN 1092-1
- ASME B16.5
- JIS B2220
- AS 2129 Table E
- AS 4087 PN 16

 For information on the materials of the process connections (→  119)

Surface roughness

Electrodes with 1.4435/304L, Alloy C-22, platinum, tantalum:

≤ 0.3 to 0.5 μm (11.8 to 19.7 μin)

(All data relate to parts in contact with fluid)

Liner with PFA:

≤ 0.4 μm (15.7 μin)

(All data relate to parts in contact with fluid)

16.11 Operability

Local operation

Display elements

- 4-line display
- In the case of order code for "Display; Operation", option **E**: white background lighting; switches to red in event of device errors
- Format for displaying measured variables and status variables can be individually configured
- Permitted ambient temperature for the display: -20 to +60 °C (-4 to +140 °F)
The readability of the display may be impaired at temperatures outside the temperature range.

Operating elements

- In the case of order code "Display; Operation", Option **C**: local operation with 3 push buttons (⊖, ⊕, ⊕)
- In the case of order code for "Display; Operation", option **E**: external operation via touch control; 3 optical keys: ⊖, ⊕, ⊕
- Operating elements also accessible in various hazardous areas

Additional functionality

- Data backup function
The device configuration can be saved in the display module.
- Data comparison function
The device configuration saved in the display module can be compared to the current device configuration.
- Data transfer function
The transmitter configuration can be transmitted to another device using the display module.

Remote operation

HART protocol

Operation via:

- HART protocol
- Operating tools via FXA191, FXA195
 - FieldCare (→ 121)
 - AMS Device Manager
 - SIMATIC PDM
- HART handheld terminals
 - Field Communicator 475
 - Field Xpert SFX100

Service interface (CDI)

Operation of the measuring device with the service interface (CDI) via:

"FieldCare" operating tool with COM DTM "CDI Communication FXA291" via Commubox FXA291

Languages

Can be operated in the following languages:

- Via local display:
 - English, German, French, Spanish, Italian, Dutch, Portuguese, Polish, Russian, Turkish, Chinese, Japanese, Bahasa (Indonesian), Vietnamese, Czech
- Via "FieldCare" operating tool:
 - English, German, French, Spanish, Italian, Chinese, Japanese

16.12 Certificates and approvals

CE mark

The measuring system is in conformity with the statutory requirements of the applicable EC Directives. These are listed in the corresponding EC Declaration of Conformity along with the standards applied.

Endress+Hauser confirms successful testing of the device by affixing to it the CE mark.

| | |
|--------------------------------|--|
| C-Tick symbol | The measuring system meets the EMC requirements of the "Australian Communications and Media Authority (ACMA)". |
| Ex approval | The devices are certified for use in hazardous areas and the relevant safety instructions are provided in the separate "Safety Instructions" (XA) document. Reference is made to this document on the nameplate. |
| Other standards and guidelines | <ul style="list-style-type: none"> ■ EN 60529 Degrees of protection provided by enclosures (IP code) ■ EN 61010-1 Protection Measures for Electrical Equipment for Measurement, Control, Regulation and Laboratory Procedures ■ IEC/EN 61326 Emission in accordance with Class A requirements. Electromagnetic compatibility (EMC requirements) ■ ANSI/ISA-61010-1 (82.02.01): 2004 Safety Requirements for Electrical Equipment for Measurement, Control and Laboratory Use - Part 1 General Requirements ■ CAN/CSA-C22.2 No. 61010-1-04 Safety Requirements for Electrical Equipment for Measurement, Control and Laboratory Use - Part 1 General Requirements ■ NAMUR NE 21 Electromagnetic compatibility (EMC) of industrial process and laboratory control equipment ■ NAMUR NE 32 Data retention in the event of a power failure in field and control instruments with microprocessors ■ NAMUR NE 43 Standardization of the signal level for the breakdown information of digital transmitters with analog output signal. ■ NAMUR NE 53 Software of field devices and signal-processing devices with digital electronics ■ NAMUR NE 105 Specifications for integrating fieldbus devices in engineering tools for field devices ■ NAMUR NE 107 Self-monitoring and diagnosis of field devices ■ NAMUR NE 131 Requirements for field devices for standard applications |

16.13 Application packages

 For an overview of the application packages that can be ordered, see the "Technical Information" document

16.14 Accessories

 For an overview of the accessories that can be ordered, see the "Technical Information" document

16.15 Documentation

 The following document types are available:

- On the CD-ROM supplied with the device
- In the Download Area of the Endress+Hauser Internet site: www.endress.com → Download

Standard documentation

| Communication | Document type | Documentation code |
|---------------|---------------|--------------------|
|---------------|---------------|--------------------|

| | | |
|------|------------------------------|----------|
| ---- | Brief Operating Instructions | KA01121D |
| ---- | Technical Information | TI01062D |

Supplementary device-dependent documentation

| Document type | Approval | Documentation code |
|---|----------------------------|---|
| Safety Instructions | ATEX/IECEX Ex d[ia], Ex tb | XA01015D |
| | ATEX/IECEX Ex ia, Ex tb | XA01016D |
| | ATEX/IECEX Ex nA, Ex ic | XA01017D |
| | cCSAus XP (Ex d) | XA01018D |
| | cCSAus IS (Ex i) | XA01019D |
| Information on the Pressure Equipment Directive | | SD01056D |
| Installation Instructions | | Specified for each individual accessory  For an overview of the accessories that can be ordered, see the "Technical Information" document |

17 Appendix































17.1 Overview of the operating menu

The following table provides an overview of the entire operating menu structure with menus and parameters. The direct access code to the parameter is given in brackets. The page reference indicates where a description of the parameter can be found in the manual.

| | | |
|--------------------------|---|--------|
| Language | | (→ 53) |
| Display/operat. | → | (→ 63) |
| Language | | (→ 53) |
| Access status display | | (→ 46) |
| Locking status | | (→ 78) |
| Display | → | (→ 63) |
| Format display | | (→ 64) |
| Contrast display | | (→ 41) |
| Backlight | | |
| Display interval | | (→ 74) |
| Operation | → | (→ 83) |
| Control totalizer 1 to 3 | | (→ 84) |
| Preset value 1 to 3 | | (→ 84) |
| Reset all totalizers | | (→ 84) |
| Setup | → | (→ 54) |
| Current output 1 | → | (→ 55) |
| Assign current output | | (→ 55) |
| Mass flow unit | | (→ 56) |
| Volume flow unit | | (→ 56) |
| Density unit | | (→ 56) |
| Fixed density | | (→ 56) |
| Current span | | (→ 56) |
| 4 mA value | | (→ 56) |
| 20 mA value | | (→ 56) |
| Failure mode | | (→ 56) |
| Failure current | | (→ 56) |

| | | |
|--------------------------------------|---|-------------------------|
| PFS output | → | (→ 56) |
| Pulse output | → | (→ 57) |
| Operating mode | | (→ 57) |
| Assign pulse output | | (→ 57) |
| Volume unit | | (→ 57) |
| Mass unit | | (→ 58) |
| Density unit | | (→ 58) |
| Fixed density | | (→ 58) |
| Pulse value | | (→ 58) |
| Pulse width | | (→ 58) |
| Failure mode | | (→ 58) |
| Invert output signal | | (→ 58) |
| Frequency output | → | (→ 59) |
| Operating mode | | (→ 59) |
| Assign frequency output | | (→ 59) |
| Volume flow unit | | (→ 60) |
| Mass flow unit | | (→ 60) |
| Density unit | | (→ 60) |
| Fixed density | | (→ 60) |
| Minimum frequency value | | (→ 60) |
| Maximum frequency value | | (→ 60) |
| Measuring value at minimum frequency | | (→ 60) |
| Measuring value at maximum frequency | | (→ 60) |
| Failure mode | | (→ 60) |
| Failure frequency | | (→ 60) |
| Invert output signal | | (→ 60) |
| Switch output | → | (→ 61) |
| Operating mode | | (→ 62) |
| Switch output function | | (→ 62) |
| Assign diagnostic behavior | | (→ 62) |



























| | |
|-------------------------------|-------------------------|
| Assign limit | (→ 63) |
| Assign flow direction check | (→ 63) |
| Assign status | (→ 63) |
| Unit | (→ 63) |
| Switch-on value | (→ 63) |
| Switch-off value | (→ 63) |
| Switch-on delay | (→ 63) |
| Switch-off delay | (→ 63) |
| Failure mode | (→ 63) |
| Invert output signal | (→ 63) |
| Display → | (→ 63) |
| Format display | (→ 64) |
| Value 1 display | (→ 64) |
| 0% bargraph value 1 | (→ 64) |
| 100% bargraph value 1 | (→ 65) |
| Value 2 display | (→ 65) |
| Value 3 display | (→ 65) |
| 0% bargraph value 3 | (→ 65) |
| 100% bargraph value 3 | (→ 65) |
| Value 4 display | (→ 65) |
| Output conduct → | (→ 65) |
| Display damping | (→ 66) |
| Output damping 1 to 2 | (→ 66) |
| Measuring mode1 to 2 | (→ 66) |
| Low flow cut off → | (→ 66) |
| Assign process variable | (→ 67) |
| On-value, low flow cut off | (→ 67) |
| Off value low flow cutoff | (→ 67) |
| Pressure shock suppression | (→ 67) |
| Empty pipe detection → | (→ 68) |
| Empty pipe detection | (→ 68) |

| | | |
|------------------------------------|---------------------------|--|
| New adjustment | | (→  68) |
| Progress | | (→  68) |
| Switch point empty pipe detection | | (→  68) |
| Response time empty pipe detection | | (→  68) |
| Advanced setup | → | (→  69) |
| Enter access code | | (→  46) |
| Device tag | | (→  70) |
| | Define access code | → (→  77) |
| | Define access code | (→  77) |
| | Confirm access code | (→  77) |
| | System units | → (→  70) |
| | Volume flow unit | (→  71) |
| | Volume unit | (→  71) |
| | Mass flow unit | (→  71) |
| | Mass unit | (→  71) |
| | Density unit | (→  71) |
| | Temperature unit | (→  71) |
| | Sensor adjustment | → (→  71) |
| | Installation direction | (→  72) |
| | Totalizer 1 to 3 | → (→  72) |
| | Assign process variable | (→  72) |
| | Unit | (→  72) |
| | Totalizer operation mode | (→  72) |
| | Failure mode | (→  72) |
| | Display | → (→  73) |
| | Format display | (→  64) |
| | Value 1 display | (→  64) |
| | 0% bargraph value 1 | (→  64) |
| | 100% bargraph value 1 | (→  65) |
| | Decimal places 1 | (→  73) |



















| | | |
|-----------------------------|-----------------------------|-------------------------|
| | Value 2 display | (→ 65) |
| | Decimal places 2 | (→ 74) |
| | Value 3 display | (→ 65) |
| | 0% bargraph value 3 | (→ 65) |
| | 100% bargraph value 3 | (→ 65) |
| | Decimal places 3 | (→ 74) |
| | Value 4 display | (→ 65) |
| | Decimal places 4 | (→ 74) |
| | Display interval | (→ 74) |
| | Display damping | (→ 74) |
| | Header | (→ 74) |
| | Header text | (→ 74) |
| | Separator | (→ 74) |
| | Backlight | (→ 74) |
| | Conf. backup disp. → | (→ 74) |
| | Operating time | (→ 75) |
| | Last backup | (→ 75) |
| | Configuration management | (→ 75) |
| | Comparison result | (→ 75) |
| Diagnostics → | | (→ 87) |
| Actual diagnostics | | (→ 96) |
| Timestamp | | |
| Previous diagnostics | | (→ 96) |
| Timestamp | | |
| Operating time from restart | | |
| Operating time | | (→ 97) |
| Diagnostics list → | | (→ 96) |
| Diagnostics1 to 5 | | (→ 96) |
| Timestamp | | |
| Event logbook → | | (→ 96) |
| Filter options | | (→ 97) |

| | | |
|---------------------------|----------------------------|---------|
| | Events list → | (→ 97) |
| Device info → | | (→ 99) |
| Device tag | | (→ 70) |
| Serial number | | (→ 99) |
| Firmware version | | (→ 100) |
| Device name | | (→ 100) |
| Order code | | (→ 100) |
| Extended order code1 to 3 | | (→ 100) |
| ENP version | | (→ 100) |
| Device revision | | (→ 100) |
| Device ID | | (→ 100) |
| Device type | | (→ 100) |
| Manufacturer ID | | (→ 100) |
| Measured values → | | (→ 81) |
| | Process variables → | (→ 81) |
| | Volume flow | (→ 82) |
| | Mass flow | (→ 82) |
| | Totalizer → | (→ 82) |
| | Totalizer value1 to 3 | (→ 82) |
| | Totalizer overflow1 to 3 | (→ 82) |
| | Output values → | (→ 82) |
| | Output current 1 | (→ 83) |
| | Measured current 1 | (→ 83) |
| | Terminal voltage 1 | (→ 83) |
| | Pulse output | (→ 83) |
| | Output frequency | (→ 83) |
| | Switch status | (→ 83) |
| Data logging → | | (→ 85) |
| Assign channel 1-4 | | (→ 86) |
| Logging interval | | (→ 86) |
| Clear logging data | | (→ 86) |



























| | | |
|------------------------------------|---|-------------------------|
| Display channel 1-4 | | (→ 86) |
| Simulation | → | (→ 76) |
| Assign simulation process variable | | (→ 76) |
| Value process variable | | (→ 76) |
| Simulation current output 1 | | (→ 76) |
| Value current output 1 | | (→ 76) |
| Frequency simulation | | (→ 76) |
| Frequency value | | (→ 77) |
| Pulse simulation | | (→ 77) |
| Pulse value | | (→ 77) |
| Switch output simulation | | (→ 77) |
| Switch status | | (→ 77) |
| Simulation device alarm | | (→ 77) |
| Device reset | → | (→ 98) |
| Device reset | | (→ 98) |
| Expert | → | (→ 35) |
| Direct access (0106) | | (→ 43) |
| Locking status (0122) | | (→ 46) |
| Access status display (0091) | | (→ 46) |
| Access status tooling (0005) | | |
| Enter access code (0003) | | (→ 46) |
| System | → | |
| Define access code | → | (→ 77) |
| Define access code | | (→ 77) |
| Confirm access code | | (→ 77) |
| Display | → | (→ 73) |
| Language (0104) | | (→ 53) |
| Format display (0098) | | (→ 64) |
| Value 1 display (0107) | | (→ 64) |
| 0% bargraph value 1 (0123) | | (→ 64) |

| | | |
|---------------------------------|---|---|
| 100% bargraph value 1 (0125) | | (→  65) |
| Decimal places 1 (0095) | | (→  73) |
| Value 2 display (0108) | | (→  65) |
| Decimal places 2 (0117) | | (→  74) |
| Value 3 display (0110) | | (→  65) |
| 0% bargraph value 3 (0124) | | (→  65) |
| 100% bargraph value 3 (0126) | | (→  65) |
| Decimal places 3 (0118) | | (→  74) |
| Value 4 display (0109) | | (→  65) |
| Decimal places 4 (0119) | | (→  74) |
| Display interval (0096) | | (→  74) |
| Display damping (0094) | | (→  74) |
| Header (0097) | | (→  74) |
| Header text (0112) | | (→  74) |
| Separator (0101) | | (→  74) |
| Contrast display (0105) | | (→  41) |
| Backlight (0111) | | (→  74) |
| Access status display (0091) | | (→  46) |
| Conf. backup disp. | → | (→  74) |
| Operating time | | (→  75) |
| Last backup | | (→  75) |
| Configuration management (0100) | | (→  75) |
| Comparison result (0103) | | (→  75) |
| Diagnostic behavior | → | |
| Alarm delay (0651) | | |
| | | Diagnostic behavior → |
| | | Assign behavior of diagnostic no. 004 (0734) (→  94) |
| | | Assign behavior of diagnostic no. 441 (0657) (→  94) |
| | | Assign behavior of diagnostic no. 442 (0658) (→  94) |

| | | | |
|-----------------|-------------------------------|--|-------------------------|
| | | Assign behavior of diagnostic no. 443 (0659) | (→ 95) |
| | | Assign behavior of diagnostic no. 531 (0733) | (→ 95) |
| | | Assign behavior of diagnostic no. 801 (0660) | (→ 95) |
| | | Assign behavior of diagnostic no. 862 (0679) | (→ 95) |
| | | Assign behavior of diagnostic no. 861 (0736) | (→ 95) |
| | | Assign behavior of diagnostic no. 937 (0735) | (→ 95) |
| | Management → | | (→ 87) |
| | Device reset (0000) | | (→ 98) |
| | Activate SW option (0029) | | |
| | Reset write protection (0029) | | |
| | Device start (0699) | | |
| Sensor → | | | |
| | Measured values → | | (→ 81) |
| | | Process variables → | (→ 81) |
| | | Volume flow (1838) | (→ 82) |
| | | Mass flow (1847) | (→ 82) |
| | | Totalizer → | (→ 82) |
| | | Totalizer value 1 to 3 (0911) | (→ 82) |
| | | Totalizer overflow 1 to 3 (0910) | (→ 82) |
| | | Output values → | (→ 82) |
| | | Output current 1 (0361) | (→ 83) |
| | | Measured current output 1 (0366) | (→ 83) |
| | | Terminal voltage 1 (0662) | (→ 83) |
| | | Pulse output (0456) | (→ 83) |
| | | Output frequency (0471) | (→ 83) |
| | | Switch status (0461) | (→ 83) |
| | System units → | | (→ 70) |

















| | | |
|---------------------------|---|--|
| Volume flow unit (0553) | | (→  71) |
| Volume unit (0563) | | (→  71) |
| Mass flow unit (0554) | | (→  71) |
| Mass unit (0574) | | (→  71) |
| Density unit (0555) | | (→  71) |
| Temperature unit (0557) | | (→  71) |
| Date/time format (2812) | | |
| User unit | → | |
| User mass text (0560) | | |
| User mass offset (0562) | | |
| User mass factor (0561) | | |
| User volume text (0567) | | |
| User volume offset (0569) | | |
| User volume factor (0568) | | |
| Process param. | → | (→  54) |
| Flow override (1839) | | (→  54) |
| Flow damping (6661) | | (→  54) |
| | | Low flow cut off → (→  66) |
| | | Assign process variable (1837) (→  67) |
| | | On value low flow cutoff (1805) (→  67) |
| | | Off value low flow cutoff (1804) (→  67) |
| | | Pressure shock suppression (1806) (→  67) |
| | | Empty pipe detection → (→  68) |
| | | Empty pipe detection (1860) (→  68) |
| | | Switch point empty pipe detection (6562) (→  68) |
| | | Response time empty pipe detection (1859) (→  68) |
| | | Empty pipe adj. value (6527) |
| | | Full pipe value (6548) |











| | | |
|---------------------------------------|-------------------------------|-------------------------|
| | Current measured value (6559) | |
| | New adjustment (6560) | (→ 68) |
| | Progress (6571) | (→ 68) |
| Calculated process variables → | | (→ 58) |
| | Reference values → | (→ 58) |
| | Fixed density (1862) | (→ 58) |
| Sensor adjustment → | | (→ 71) |
| | Installation direction (1809) | (→ 72) |
| | Integration time (6533) | |
| | Measuring period (6536) | |
| | Variable adjust → | (→ 71) |
| | Volume flow factor (1832) | (→ 71) |
| | Volume flow offset (1831) | (→ 71) |
| | Mass flow factor (1846) | (→ 71) |
| | Mass flow offset (1841) | (→ 71) |
| | Calibration → | |
| | Nominal diameter (2807) | |
| | Calibration factor (6522) | |
| | Zero point (6546) | |
| Output → | | |
| | Current output 1 → | (→ 55) |
| | Assign current output (0359) | (→ 55) |
| | Current span (0353) | (→ 56) |
| | Fixed current (0365) | (→ 56) |
| | 4 mA value (0367) | (→ 56) |
| | 20 mA value (0372) | (→ 56) |
| | Measuring mode (0351) | (→ 66) |
| | Damping (0363) | (→ 66) |
| | Failure mode (0364) | (→ 56) |
| | Failure current (0352) | (→ 56) |

| | | |
|---|---|--|
| Output current 1 (0361) | | (→  83) |
| Start-up mode (0368) | | |
| Start-up current (0369) | | |
| Measured current output 1 (0366) | | (→  83) |
| Terminal voltage 1 (0662) | | (→  83) |
| PFS output | → | (→  56) |
| Pulse output | → | (→  57) |
| Operating mode (0469) | | (→  57) |
| Assign pulse output (0460) | | (→  57) |
| Value per pulse (0455) | | (→  58) |
| Pulse width (0452) | | (→  58) |
| Measuring mode (0457) | | (→  66) |
| Failure mode (0480) | | (→  58) |
| Pulse output (0456) | | (→  83) |
| Invert output signal (0470) | | (→  60) |
| Frequency output | → | (→  59) |
| Operating mode (0469) | | (→  59) |
| Assign frequency output (0478) | | (→  59) |
| Minimum frequency value (0453) | | (→  60) |
| Maximum frequency value (0454) | | (→  60) |
| Measuring value at minimum frequency (0476) | | (→  60) |
| Measuring value at maximum frequency (0475) | | (→  60) |
| Measuring mode (0479) | | (→  66) |
| Damping output (0477) | | (→  66) |
| Failure mode (0451) | | (→  60) |
| Failure frequency (0474) | | (→  60) |
| Output frequency (0471) | | (→  83) |
| Invert output signal (0470) | | (→  60) |

| | | |
|------------------------|------------------------------------|---------|
| | Switch output → | (→ 61) |
| | Switch output function (0481) | (→ 62) |
| | Assign diagnostic behavior (0482) | (→ 62) |
| | Assign limit (0483) | (→ 63) |
| | Switch-on value (0466) | (→ 63) |
| | Switch-off value (0464) | (→ 63) |
| | Assign flow direction check (0484) | (→ 63) |
| | Assign status (0485) | (→ 63) |
| | Switch-on delay (0467) | (→ 63) |
| | Switch-off delay (0465) | (→ 63) |
| | Failure mode (0486) | (→ 63) |
| | Switch status (0461) | (→ 83) |
| | Invert output signal (0470) | (→ 63) |
| Communication → | HART output → | (→ 51) |
| | Configuration → | |
| | Burst mode (0208) | |
| | Burst command (0207) | |
| | HART address (0219) | |
| | No. of preambles (0217) | |
| | HART short tag (0220) | |
| | Information → | (→ 99) |
| | Device revision (0204) | (→ 100) |
| | Device ID (0221) | (→ 100) |
| | Device type (0222) | (→ 100) |
| | Manufacturer ID (0223) | (→ 100) |
| | HART revision (0205) | (→ 51) |
| | HART descriptor (0212) | |
| | HART message (0216) | |
| | HART date code (0202) | |

| | | | |
|--|---------------------------|---------------------------------------|-------------------------|
| | | Hardware revision (0206) | |
| | | Software revision (0224) | |
| | Output → | | (→ 51) |
| | | Assign PV (0234) | (→ 51) |
| | | Primary variable (PV) (0201) | (→ 51) |
| | | Assign SV (0235) | (→ 51) |
| | | Secondary variable (SV) (0226) | (→ 51) |
| | | Assign TV (0236) | (→ 51) |
| | | Tertiary variable (TV) (0228) | (→ 51) |
| | | Assign QV (0237) | (→ 51) |
| | | Quaternary variable (QV) (0203) | (→ 51) |
| | Application → | | |
| | | Reset all totalizers (2806) | (→ 84) |
| | Totalizer 1 to 3 → | | (→ 72) |
| | | Assign process variable (0914) | (→ 72) |
| | | Unit (0915) | (→ 72) |
| | | Totalizer operation mode (0908) | (→ 72) |
| | | Control totalizer 1 to 3 (0912) | (→ 84) |
| | | Preset value 1 to 3 (0913) | (→ 84) |
| | | Failure mode (0901) | (→ 72) |
| | Diagnostics → | | (→ 87) |
| | | Actual diagnostics (0691) | (→ 96) |
| | | Timestamp | |
| | | Previous diagnostics (0690) | (→ 96) |
| | | Timestamp | |
| | | Operating time from restart (0653) | - |
| | | Operating time (0652) | (→ 97) |
| | Diagnostics list → | | (→ 96) |

| | | |
|--|---|---|
| Diagnostics 1 to 5 (692 to 696) | | (→  96) |
| Timestamp | | |
| Event logbook | → | (→  96) |
| Filter options (0705) | | (→  97) |
| | | Events list → (→  97) |
| Device info | → | (→  99) |
| Device tag (0011) | | (→  70) |
| Serial number (0009) | | (→  99) |
| Firmware version (0010) | | (→  100) |
| Device name (0013) | | (→  100) |
| Order code (0008) | | (→  100) |
| Extended order code 1 to 3 (0023, 0021, 0022) | | (→  100) |
| ENP version (0012) | | (→  100) |
| Configuration counter (0233) | | |
| Data logging | → | (→  85) |
| Assign channel 1-4 (851 to 854) | | (→  86) |
| Logging interval (0856) | | (→  86) |
| Clear logging data (0855) | | (→  86) |
| Display channel 1-4 | | (→  86) |
| Min/max values | → | |
| Reset min/max values (6541) | | |
| | | Terminal voltage → |
| | | Minimum value (0689) |
| | | Maximum value (0663) |
| | | Average value (0689) |
| | | Main electronic temperature → |
| | | Minimum value (6547) |
| | | Maximum value (6545) |
| | | IO module temperature → |

| | | |
|---|----------------------|--|
| | Minimum value (0688) | |
| | Maximum value (0665) | |
| | Average value (0697) | |
| Simulation | → | (→  76) |
| Assign simulation process variable (1810) | | (→  76) |
| Value process variable (1811) | | (→  76) |
| Simulation current output 1 (0354) | | (→  76) |
| Value current output 1 (0355) | | (→  76) |
| Frequency simulation (0472) | | (→  76) |
| Frequency value (0473) | | (→  77) |
| Pulse simulation (0458) | | (→  77) |
| Pulse value (0459) | | (→  77) |
| Switch output simulation (0462) | | (→  77) |
| Simulation device alarm (0654) | | (→  77) |

Index

A

- Access authorization to parameters
 - Read access 46
 - Write access 46
- Access code 46
 - Incorrect input 46
- Adapters 20
- Adapting the diagnostic behavior 92
- Ambient temperature
 - Influence 112
- Ambient temperature range 19
- AMS Device Manager 50
 - Function 50
- Application 8, 106
- Application packages 121
- Applicator 106
- Approvals 120

C

- Cable entries
 - Technical data 110
- Cable entry
 - Degree of protection 32
- CE mark 9, 120
- Certificates 120
- Check
 - Installation 25
 - Post-connection 32
- Checklist
 - Post-connection check 32
 - Post-installation check 25
- Cleaning
 - Exterior cleaning 104
 - Interior cleaning 104
- Commissioning 53
 - Advanced settings 69
 - Configuring the measuring device 54
- Communication-specific data 51
- Conductivity 113
- Connecting cable 26
- Connecting the measuring device 28
- Connection
 - see Electrical connection
- Connection examples, potential equalization 30
- Connection preparations 28
- Connection tools 26
- Context menu
 - Closing 41
 - Explanation 41
 - Opening 41
- C-Tick symbol 121
- Current consumption 110

D

- Declaration of Conformity 9
- Define access code 77

- Degree of protection 32, 113
- Design
 - Measuring device 10
- Designated use 8
- Device components 10
- Device description files 51
- Device documentation
 - Supplementary documentation 7
- Device locking, status 81
- Device name
 - Sensor 13
 - Transmitter 12
- Device repair 102
- Device revision 51
- Device type ID 51
- Diagnostic behavior
 - Explanation 90
 - Symbols 90
- Diagnostic information
 - Design, description 90
 - FieldCare 92
 - Local display 89
 - Overview 93
 - Remedy information 93
- Diagnostic list 96
- Diagnostic message 89
- Diagnostics
 - Symbols 89
- DIP switch
 - see Write protection switch
- Direct access 43
- Direct access code 38
- Disabling write protection 77
- Display
 - see Local display
 - Current diagnostic event 96
 - Previous diagnostic event 96
- Display area
 - For operational display 36
 - In the navigation view 38
- Display values
 - For device info 99
 - For locking status 81
 - For output values 83
 - For process variables 82
 - For the totalizer 82
- Disposal 100
- Document
 - Function 5
 - Symbols used 5
- Documentation 121
- Document function 5
- Down pipe 17

E

- Electrical connection

| | |
|-------------------------------|-----|
| Commubox FXA195 | 48 |
| Commubox FXA291 | 49 |
| Degree of protection | 32 |
| Field Communicator | 48 |
| Handheld terminals | 48 |
| Measuring device | 26 |
| Operating tools | 48 |
| Via HART protocol | 48 |
| Via service interface (CDI) | 49 |
| Electromagnetic compatibility | 113 |
| Enabling write protection | 77 |
| Endress+Hauser services | |
| Maintenance | 104 |
| Repair | 103 |
| Environment | |
| Ambient temperature | 19 |
| Mechanical load | 113 |
| Shock resistance | 113 |
| Storage temperature | 112 |
| Vibration resistance | 113 |
| Error messages | |
| see Diagnostic messages | |
| Event history | 96 |
| Events list | 96 |
| Ex approval | 121 |
| Extended order code | |
| Sensor | 13 |
| Transmitter | 12 |
| Exterior cleaning | 104 |
| F | |
| FieldCare | 49 |
| Device description file | 51 |
| Function | 49 |
| User interface | 50 |
| Field Communicator | |
| Function | 50 |
| Field of application | |
| Residual risks | 9 |
| Field Xpert | 49 |
| Function | 49 |
| Filtering the event logbook | 97 |
| Firmware | |
| Release date | 51 |
| Version | 51 |
| Fitted electrodes | 119 |
| Flow direction | 18 |
| Flow limit | 116 |
| Function check | 53 |
| Functions | |
| see Parameter | |
| Function scope | |
| AMS Device Manager | 50 |
| Field Communicator | 50 |
| Field Communicator 475 | 50 |
| Field Xpert | 49 |
| SIMATIC PDM | 50 |

G

| | |
|--------------------|-----|
| Galvanic isolation | 109 |
|--------------------|-----|

H

| | |
|---------------------------|-----|
| Hardware write protection | 78 |
| HART protocol | 120 |
| Device variables | 51 |
| Measured variables | 51 |
| Help text | |
| Calling up | 44 |
| Close | 44 |
| Explanation | 44 |
| HistoROM | 74 |

I

| | |
|----------------------------------|--------|
| I/O electronics module | 10, 29 |
| Identifying the measuring device | 12 |
| Incoming acceptance | 11 |
| Influence | |
| Ambient temperature | 112 |
| Information on the document | 5 |
| Inlet runs | 19 |
| Input | 106 |
| Input mask | 39 |
| Inspection check | |
| Received goods | 11 |
| Installation | 17 |
| Installation conditions | |
| Adapters | 20 |
| Down pipe | 17 |
| Inlet and outlet runs | 19 |
| Mounting location | 17 |
| Orientation | 18 |
| Partially filled pipe | 18 |
| System pressure | 20 |
| Vibrations | 20 |
| Installation dimensions | 19 |
| Interior cleaning | 104 |

K

| | |
|-------------|----|
| Keypad lock | |
| Disabling | 46 |
| Enabling | 46 |

L

| | |
|------------------------------|-----|
| Languages, operation options | 120 |
| Line recorder | 85 |
| Load | 27 |
| Local display 36, 89, 120 | |
| see Diagnostic message | |
| see In alarm condition | |
| see Operational display | |
| Editing view | 39 |
| Navigation view | 37 |
| Low flow cut off | 109 |

M

| | |
|-------------------------|-----|
| Main electronics module | 10 |
| Maintenance tasks | 104 |

- Managing the device configuration 74
- Manufacturer ID 51
- Manufacturing date 12, 13
- Materials 118
- Maximum measured error 111
- Measured variables
 - see Process variables
 - Calculated 106
 - Measured 106
- Measuring and test equipment 104
- Measuring device
 - Configuration 54
 - Conversion 102
 - Design 10
 - Disposal 101
 - Integrating via HART protocol 51
 - Mounting the sensor 22
 - Mounting the ground cable/ground disks 22
 - Mounting the seals 22
 - Screw tightening torques 22
 - Preparing for electrical connection 28
 - Preparing for mounting 21
 - Removing 100
 - Repair 102
 - Switching on 53
- Measuring principle 106
- Measuring range 106
- Measuring system 106
- Measuring tube specification 118
- Mechanical load 113
- Media 8
- Medium temperature range 113
- Menus
 - For measuring device configuration 54
 - For specific settings 69
- Mounting dimensions
 - see Installation dimensions
- Mounting location 17
- Mounting preparations 21
- Mounting requirements
 - Installation dimensions 19
- Mounting tools 21
- N**
- Nameplate
 - Sensor 13
 - Transmitter 12
- Navigation path (navigation view) 38
- Navigation view
 - In the submenu 37
 - In the wizard 37
- Numeric editor 39
- O**
- Operable flow range 107
- Operating elements 41, 90
- Operating keys
 - see Operating elements
- Operating menu
 - Menus, submenus 34
 - Structure 34
 - Submenus and user roles 35
- Operating menu overview
 - Operators and maintenance 123
- Operating philosophy 35
- Operation 81
- Operational display 36
- Operational safety 9
- Operation options 33
- Order code 12, 13
- Orientation (vertical, horizontal) 18
- Outlet runs 19
- Output 107
- Output signal 107
- P**
- Packaging disposal 16
- Parameters
 - Changing 45
 - Enter a value 45
- Parameter settings
 - Empty pipe detection (EPD) 68
 - For conf. backup disp. 75
 - For current output 55
 - For data logging 85
 - For local display 64, 73
 - For low flow cut off 67
 - For output conditioning 66
 - For sensor adjustment 71
 - For simulation 76
 - For switch output 62
 - For system units 71
 - For the frequency output 59
 - For the operation 84
 - For the pulse output 57
 - For the tag name 70
 - For the totalizer 72
- Partially filled pipe 18
- Performance characteristics 111
- Post-connection check (checklist) 32
- Post-installation check 53
- Post-installation check (checklist) 25
- Potential equalization 30
- Power consumption 110
- Power supply failure 110
- Pressure loss 116
- Pressure-temperature ratings 114, 116
- Pressure tightness 116
- Process
 - Conductivity 113
 - Flow limit 116
 - Medium temperature 113
 - Pressure loss 116
 - Pressure-temperature ratings 114
 - Pressure tightness 116
- Process connections 119
- Product safety 9
- Protecting parameter settings 77

R

| | |
|--------------------------------|-----|
| Read access | 46 |
| Reading off measured values | 81 |
| Recalibration | 104 |
| Reference operating conditions | 111 |
| Registered trademarks | 10 |
| Remedy information | |
| Calling up | 91 |
| Closing | 91 |
| Remote operation | 120 |
| Repair | 102 |
| Notes | 102 |
| Repair of a device | 102 |
| Repeatability | 112 |
| Replacement | |
| Device components | 102 |
| Requirements for personnel | 8 |
| Returning devices | 105 |

S

| | |
|---|--------|
| Safety | 8 |
| Screw tightening torques | 22 |
| Sensor | |
| Mounting | 22 |
| Serial number | 12, 13 |
| Service interface (CDI) | 120 |
| Settings | |
| Adapting the measuring device to the process conditions | 83 |
| Advanced display configurations | 73 |
| Current output | 55 |
| Device reset | 98 |
| Device tag | 70 |
| Empty pipe detection (EPD) | 68 |
| Local display | 63 |
| Low flow cut off | 66 |
| Managing the device configuration | 74 |
| Operating language | 53 |
| Output conditioning | 65 |
| Pulse/frequency/switch output | 56 |
| Resetting the totalizer | 83 |
| Sensor adjustment | 71 |
| Simulation | 76 |
| System units | 70 |
| Totalizer | 72 |
| Totalizer reset | 83 |
| Setting the operating language | 53 |
| Shock resistance | 113 |
| Showing data logging | 85 |
| Signal on alarm | 108 |
| SIMATIC PDM | 50 |
| Function | 50 |
| Software release | 51 |
| Spare part | 102 |
| Spare parts | 102 |
| Standards and guidelines | 121 |
| Status area | |
| For operational display | 36 |
| In the navigation view | 38 |

| | |
|---|---------|
| Status signals | 89 |
| Storage conditions | 15 |
| Storage temperature | 15 |
| Storage temperature range | 112 |
| Structure | |
| Operating menu | 34 |
| Submenu | |
| Conf. backup disp. | 75 |
| Data logging | 85 |
| Define access code | 77 |
| Device info | 99 |
| Events list | 96 |
| Local display | 73 |
| Operation | 84 |
| Output values | 83 |
| Overview | 35 |
| Process variables | 81 |
| Sensor adjustment | 71 |
| Simulation | 76 |
| System units | 70 |
| Totalizer | 72, 82 |
| Supply unit | |
| Requirements | 27 |
| Supply voltage | 27, 110 |
| Surface roughness | 119 |
| Symbols | |
| For communication | 36 |
| For correction | 39 |
| For diagnostic behavior | 36 |
| For locking | 36 |
| For measured variable | 36 |
| For measurement channel number | 36 |
| For menus | 38 |
| For parameters | 38 |
| For status signal | 36 |
| For submenu | 38 |
| For wizard | 38 |
| In the status area of the local display | 36 |
| In the text and numeric editor | 39 |
| System design | |
| see Measuring device design | |
| Measuring system | 106 |
| System integration | 51 |
| System pressure | 20 |
| T | |
| Technical data, overview | 106 |
| Temperature range | |
| Ambient temperature range for display | 120 |
| Storage temperature | 15 |
| Terminal assignment | 27, 29 |
| Terminals | 110 |
| Terminal voltage | 27 |
| Text editor | 39 |
| Tools | |
| Electrical connection | 26 |
| For mounting | 21 |
| Transport | 15 |
| Tool tip | |

| | |
|---|----------|
| see Help text | |
| Transmitter | |
| Connecting the signal cables | 29 |
| Turning the display module | 25 |
| Turning the housing | 24 |
| Transporting the measuring device | 15 |
| Troubleshooting | |
| General | 87 |
| Turning the display module | 25 |
| Turning the electronics housing | |
| see Turning the transmitter housing | |
| Turning the transmitter housing | 24 |
| U | |
| Use of the measuring device | |
| see Designated use | |
| Borderline cases | 8 |
| Incorrect use | 8 |
| User roles | 35 |
| V | |
| Version data for the device | 51 |
| Vibration resistance | 113 |
| Vibrations | 20 |
| W | |
| W@M | 102, 104 |
| W@M Device Viewer | 12, 102 |
| Weight | |
| Compact version | 117 |
| Transport (notes) | 15 |
| Wizard | |
| Current output | 55 |
| Display | 64 |
| Empty pipe detection (EPD) | 68 |
| Frequency output | 59 |
| Low flow cut off | 67 |
| Output conditioning | 66 |
| Pulse output | 57 |
| Switch output | 61 |
| Workplace safety | 9 |
| Write access | 46 |
| Write protection | |
| Via access code | 77 |
| Via write protection switch | 78 |
| Write protection switch | 78 |

Declaration of Hazardous Material and De-Contamination *Erklärung zur Kontamination und Reinigung*

RA No.

Please reference the Return Authorization Number (RA#), obtained from Endress+Hauser, on all paperwork and mark the RA# clearly on the outside of the box. If this procedure is not followed, it may result in the refusal of the package at our facility.
Bitte geben Sie die von E+H mitgeteilte Rücklieferungsnummer (RA#) auf allen Lieferpapieren an und vermerken Sie diese auch außen auf der Verpackung. Nichtbeachtung dieser Anweisung führt zur Ablehnung ihrer Lieferung.

Because of legal regulations and for the safety of our employees and operating equipment, we need the "Declaration of Hazardous Material and De-Contamination", with your signature, before your order can be handled. Please make absolutely sure to attach it to the outside of the packaging.

Aufgrund der gesetzlichen Vorschriften und zum Schutz unserer Mitarbeiter und Betriebseinrichtungen, benötigen wir die unterschriebene "Erklärung zur Kontamination und Reinigung", bevor Ihr Auftrag bearbeitet werden kann. Bringen Sie diese unbedingt außen an der Verpackung an.

Type of instrument / sensor

Geräte-/Sensortyp _____

Serial number

Seriennummer _____

Used as SIL device in a Safety Instrumented System / Einsatz als SIL Gerät in Schutzeinrichtungen

Process data / Prozessdaten

Temperature / Temperatur _____ [°F] _____ [°C]

Pressure / Druck _____ [psi] _____ [Pa]

Conductivity / Leitfähigkeit _____ [µS/cm]

Viscosity / Viskosität _____ [cp] _____ [mm²/s]

Medium and warnings

Warnhinweise zum Medium



| | Medium / concentration <i>Medium / Konzentration</i> | Identification CAS No. | flammable <i>entzündlich</i> | toxic <i>giftig</i> | corrosive <i>ätzend</i> | harmful/ irritant <i>gesundheitsschädlich/ reizend</i> | other * <i>sonstiges*</i> | harmless <i>unbedenklich</i> |
|---|---|---------------------------|---------------------------------|------------------------|----------------------------|--|------------------------------|---------------------------------|
| Process medium <i>Medium im Prozess</i> | | | | | | | | |
| Medium for process cleaning <i>Medium zur Prozessreinigung</i> | | | | | | | | |
| Returned part cleaned with <i>Medium zur Endreinigung</i> | | | | | | | | |

* explosive; oxidizing; dangerous for the environment; biological risk; radioaktiv

* *explosiv; brandfördernd; umweltgefährlich; biogefährlich; radioaktiv*

Please tick should one of the above be applicable, include safety data sheet and, if necessary, special handling instructions.

Zutreffendes ankreuzen; trifft einer der Warnhinweise zu, Sicherheitsdatenblatt und ggf. spezielle Handhabungsvorschriften beilegen.

Description of failure / Fehlerbeschreibung _____

Company data / Angaben zum Absender

| | |
|---|---|
| Company / Firma _____ | Phone number of contact person / Telefon-Nr. Ansprechpartner: _____ |
| Address / Adresse _____ | Fax / E-Mail _____ |
| Your order No. / Ihre Auftragsnr. _____ | |

"We hereby certify that this declaration is filled out truthfully and completely to the best of our knowledge. We further certify that the returned parts have been carefully cleaned. To the best of our knowledge they are free of any residues in dangerous quantities."

"Wir bestätigen, die vorliegende Erklärung nach unserem besten Wissen wahrheitsgetreu und vollständig ausgefüllt zu haben. Wir bestätigen weiter, dass die zurückgesandten Teile sorgfältig gereinigt wurden und nach unserem besten Wissen frei von Rückständen in gefahrbringender Menge sind."

(place, date / Ort, Datum)

Name, dept./Abt. (please print / bitte Druckschrift)

Signature / Unterschrift

www.endress.com/worldwide

Endress+Hauser 

People for Process Automation
