

Operating Instructions

Smartec CLD18

Compact inductive conductivity measurement for
the food and beverage industry

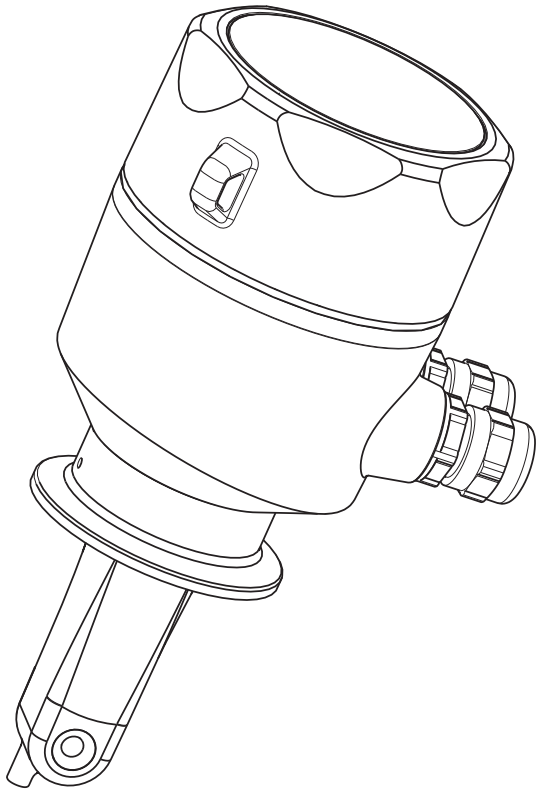

Documentation information

Warnings

The structure, signal words and color coding of the warnings follow the specifications of ANSI Z535.6 ("Product safety information in product manuals, instructions and other collateral materials").

Safety message structure	Meaning
⚠ DANGER Causes (/consequences) Possible consequences if ignored ▶ Corrective action	This symbol alerts you to a dangerous situation. Failure to avoid the situation will result in a fatal or serious injury.
⚠ WARNING Causes (/consequences) Possible consequences if ignored ▶ Corrective action	This symbol alerts you to a dangerous situation. Failure to avoid the situation can result in a fatal or serious injury.
⚠ CAUTION Causes (/consequences) Possible consequences if ignored ▶ Corrective action	This symbol alerts you to a dangerous situation. Failure to avoid this situation can result in minor or more serious injuries.
NOTICE Cause/situation Possible consequences if ignored ▶ Action/note	This symbol alerts you to situations that can result in damage to property and equipment.

Symbols used



Additional information, tips



Permitted or recommended



Forbidden or not recommended

Table of contents

1	Basic safety instructions	4	10	Repair	37
1.1	Requirements for personnel	4	10.1	Return	37
1.2	Designated use	4	10.2	Disposal	37
1.3	Occupational safety	4			
1.4	Operational safety	5	11	Accessories	38
1.5	Product safety	5	11.1	Standard solutions	38
2	Incoming acceptance and product identification	6	12	Technical data	39
2.1	Incoming acceptance	6	12.1	Input	39
2.2	Product identification	6	12.2	Output	40
2.3	Certificates and approvals	7	12.3	Power supply	40
3	Product description	8	12.4	Performance characteristics	41
4	Installation	9	12.5	Environment	42
4.1	Installation conditions	9	12.6	Process	43
4.2	Mounting the compact device	13	12.7	Mechanical construction	44
4.3	Post-installation check	13			
5	Electrical connection	14		Index	46
5.1	Connecting the transmitter	14			
5.2	Guaranteeing the degree of protection	16			
5.3	Post-connection check	16			
6	Operation options	17			
7	Commissioning	20			
7.1	Switching on the device	20			
7.2	Display settings (Display menu)	20			
7.3	Device configuration (Setup menu)	21			
7.4	Extended setup (Extended Setup menu)	22			
7.5	Calibration (Calibration menu)	28			
8	Diagnostics and troubleshooting	31			
8.1	Device diagnostics (Diagnostics menu)	31			
8.2	Troubleshooting instructions	32			
8.3	Diagnostic messages	33			
9	Maintenance	36			
9.1	Cleaning the housing	36			

1 Basic safety instructions

1.1 Requirements for personnel

- ▶ Installation, commissioning, operation and maintenance of the measuring system must only be carried out by specially trained technical personnel.
- ▶ The technical personnel must be authorized to perform such tasks by the owner-operator.
- ▶ The electrical connection must only be established by an electrical technician.
- ▶ The technical personnel must have read and understood these Operating Instructions and must follow the instructions they contain.
- ▶ Faults at the measuring point may only be rectified by authorized and properly trained personnel.

 Repairs not described in the Operating Instructions supplied may only be carried out directly at the manufacturer's or by the service organization.

1.2 Designated use

The compact measuring system is used for inductive conductivity measurement in liquids with medium to high conductivity.

Any other use than the one described here compromises the safety of persons and the entire measuring system and is therefore not permitted.

The manufacturer is not liable for damage caused by improper or non-designated use.

NOTICE

Use outside specifications

Incorrect measurements, malfunctions and even measuring point failure are possible

- ▶ Only operate the product in line with the product specifications.
- ▶ Pay particular attention to the technical data on the nameplate.

1.3 Occupational safety

As the user, you are responsible for complying with the following safety regulations:

- Explosion protection guidelines (only devices approved for use in explosion hazardous areas)
- Installation guidelines
- Local standards and regulations

1.4 Operational safety

- ▶ Prior to commissioning the entire measuring point, check that all connections are correct. Ensure that electrical cables and hose connections are not damaged.
- ▶ Do not operate damaged products. Secure them against unintentional startup. Mark the damaged product as defective.
- ▶ If faults cannot be rectified, take the products out of service and secure them against unintentional startup.

1.5 Product safety

The product is designed to meet state-of-the-art safety requirements, has been tested and left the factory in a condition in which it is safe to operate.

The applicable regulations and European standards have been taken into consideration.

2 Incoming acceptance and product identification

2.1 Incoming acceptance

- Make sure the packaging is not damaged!
- Inform your supplier of any damage to the packaging. Keep the damaged packaging until any issues have been resolved.
- Make sure the contents are not damaged!
- Inform your supplier of any damage to the contents. Keep the damaged goods until any issues have been resolved.
- Check the delivery to make sure nothing is missing. Compare it against the shipping documents and your order.
- Pack the product for storage and transportation in such a way that it is reliably protected against impact and moisture. The original packaging provides optimum protection. In addition, the permitted ambient conditions must be observed (see "Technical data").
- If you have any questions, contact your supplier or your local Sales Center.

2.2 Product identification

2.2.1 Nameplate

The nameplate contains the following information:

- Manufacturer data
- Order code
- Extended order code
- Serial number
- Operating conditions
- Safety symbols

Compare the order code indicated on the nameplate with your order.

2.2.2 Identifying the product

You can find the order code and serial number of your device:

- On the nameplate
- In the shipping documents

 To find out the version of your product, enter the order code indicated on the nameplate in the search screen at the following address: www.products.endress.com/order-ident

2.2.3 Scope of delivery

The delivery comprises:

- A Smartec CLD18 measuring system in the version ordered
- Operating Instructions BA01149C/07/EN

2.3 Certificates and approvals

FDA

All materials in contact with the product are FDA-listed materials (apart from the PVC process connections).

3-A

Certification in accordance with the 3-A Standard 74-06 ("3-A Sanitary Standards for Sensor and Sensor Fittings and Connections Used on Milk and Milk Products Equipment").

Declaration of Conformity

The product meets the requirements of the harmonized European standards.

As such, it meets the legal regulations of the EC directives.

The manufacturer confirms successful testing of the product by affixing to it the **CE** mark.

3 Product description

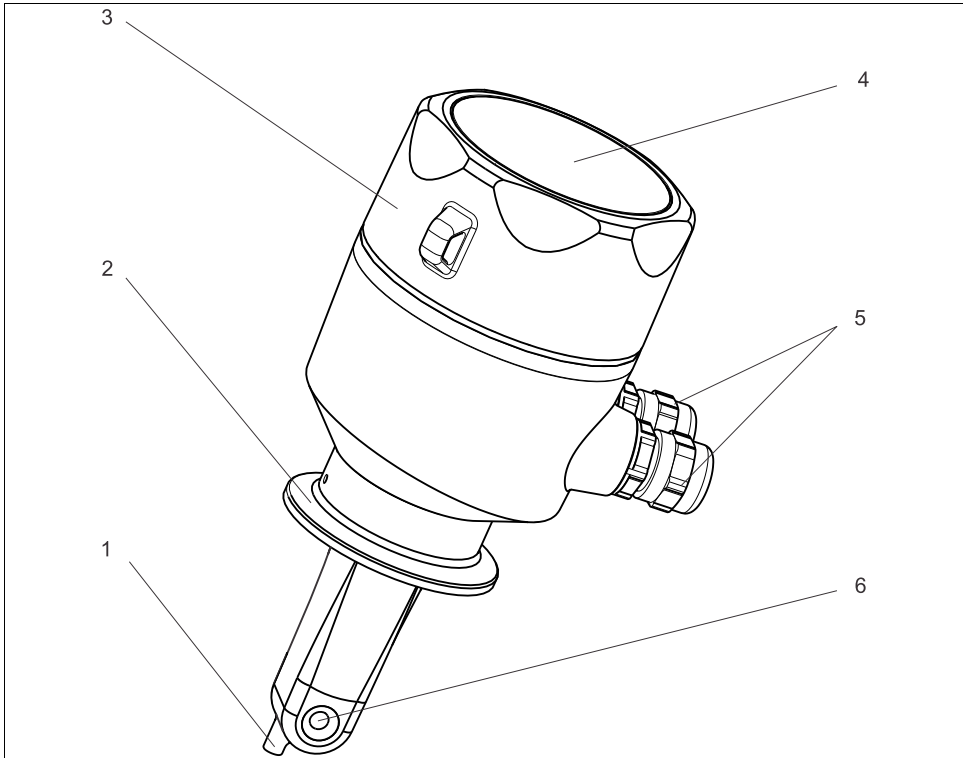

Fig. 1: Elements

a0019184

- 1 Temperature sensor
- 2 Process connection
- 3 Removable housing cover
- 4 Window for display
- 5 Cable glands
- 6 Flow opening of the sensor

4 Installation

4.1 Installation conditions

The sensor must be fully immersed in the liquid. No air bubbles should occur in the area of the sensor.

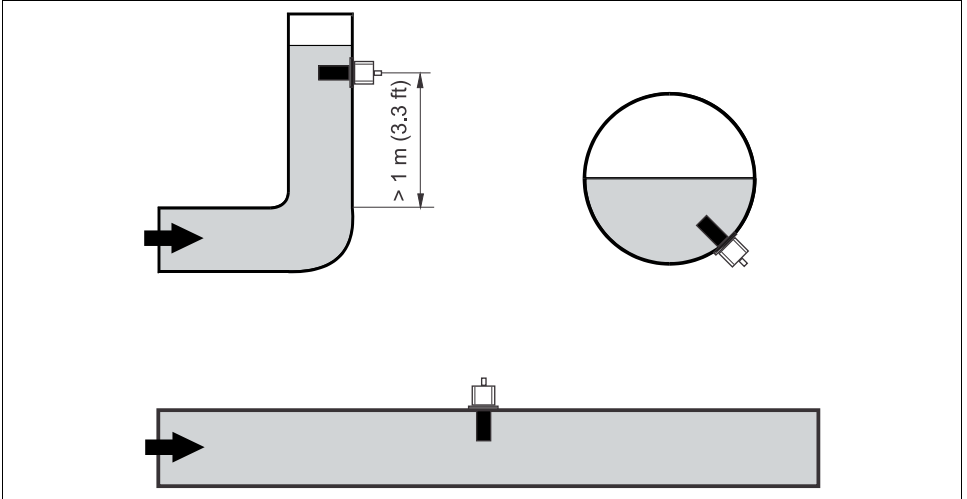

a0017691

Fig. 2: Orientation of conductivity sensors



If there is a change in the direction of flow (after a pipe bend), this can cause turbulence in the medium. Install the sensor at a distance of at least 1 m (3.3 ft) from a pipe bend.

The product should flow along the hole of the sensor (see the arrows on the housing). Product can flow in both directions through the symmetrical measuring channel.

In confined installation conditions, the walls affect the ionic current in the liquid. The installation factor compensates for this effect. The installation factor can be entered in the device for the measurement, or the cell constant is corrected by multiplying by the installation factor.

The value for the installation factor depends on the diameter and the conductivity of the pipe nozzle, as well as the distance "a" between the wall and the sensor.

If there is a sufficient distance between the wall and the sensor ($a > 20$ mm, from DN 60) the installation factor f does not need to be taken into consideration ($f = 1.00$).

If the distance from the wall is smaller, the installation factor increases for electrically insulating pipes ($f > 1$), and decreases for electrically conductive pipes ($f < 1$).

It can be measured using calibration solutions, or a close approximation can be determined from the following diagram.

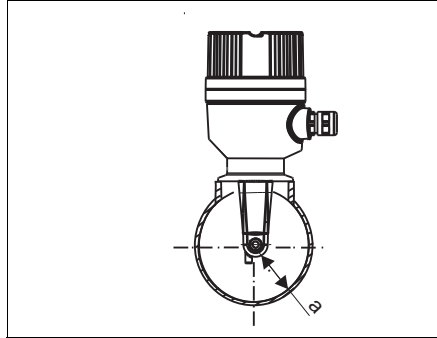

Fig. 3: CLD18 installation

a0018962

a Distance from wall

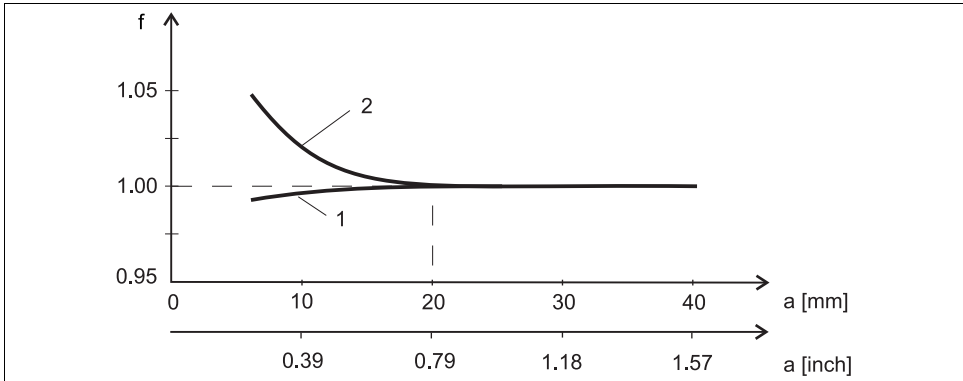
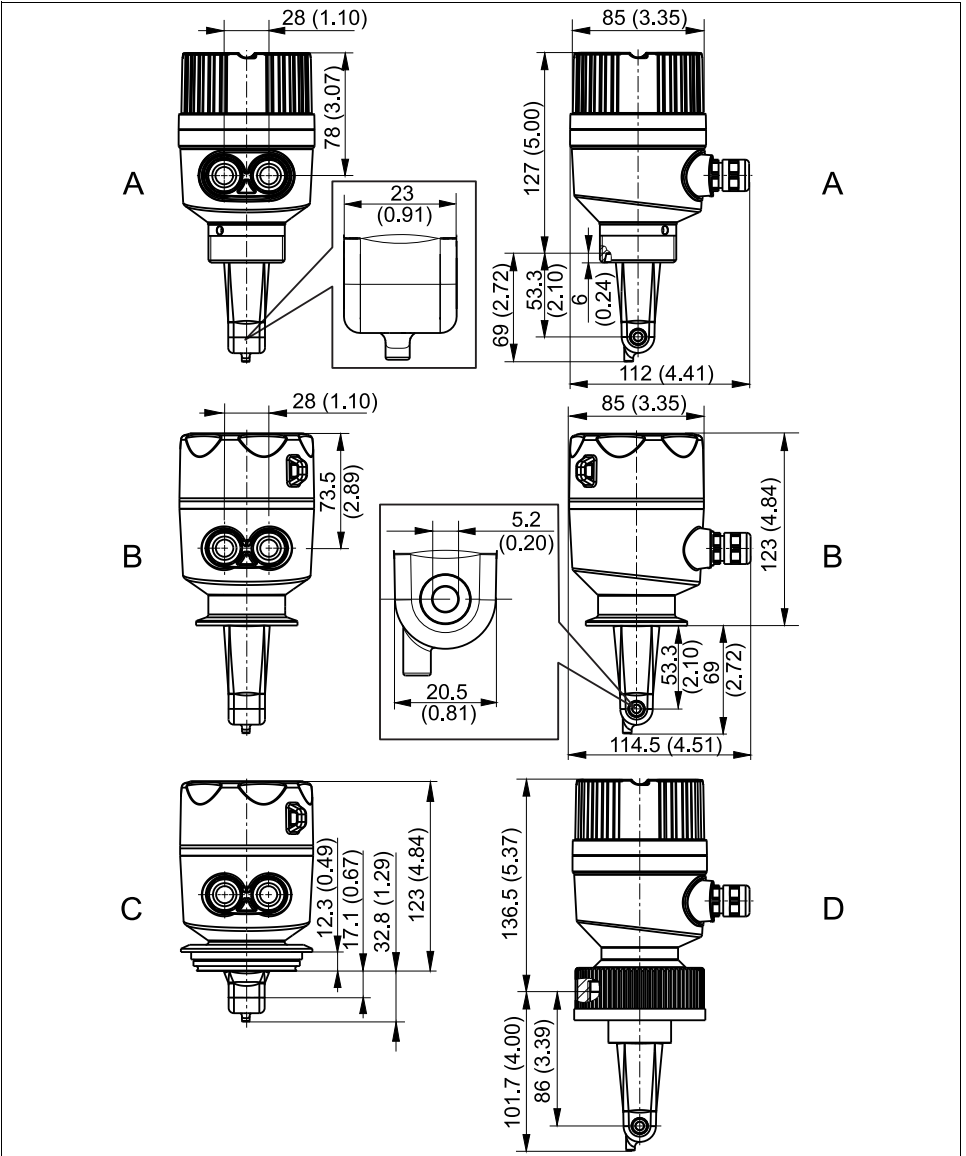

Fig. 4: Relationship between the installation factor "f" and the distance from wall "a"

a0020517

- 1 Electrically conductive pipe wall
- 2 Electrically insulating pipe wall

i Install the measuring system in such a way that the housing is not exposed to direct sunshine.



a0020394

Fig. 5: Dimensions in mm (inch) and versions (examples)

- A Plastic housing with thread G 1½
- B Stainless steel housing with ISO 2852 Clamp 2"
- C Stainless steel housing with Varivent DN 40 to 125
- D Plastic housing with coupling nut 2½" PVC

Installation example

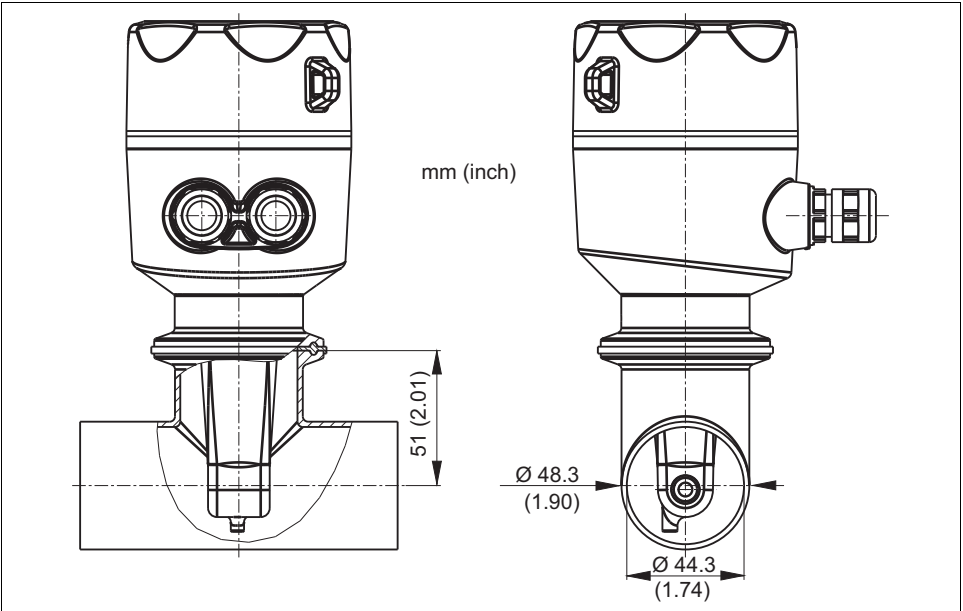

Fig. 6: Installation in DN 40 pipe with Tri-Clamp 2" process connection

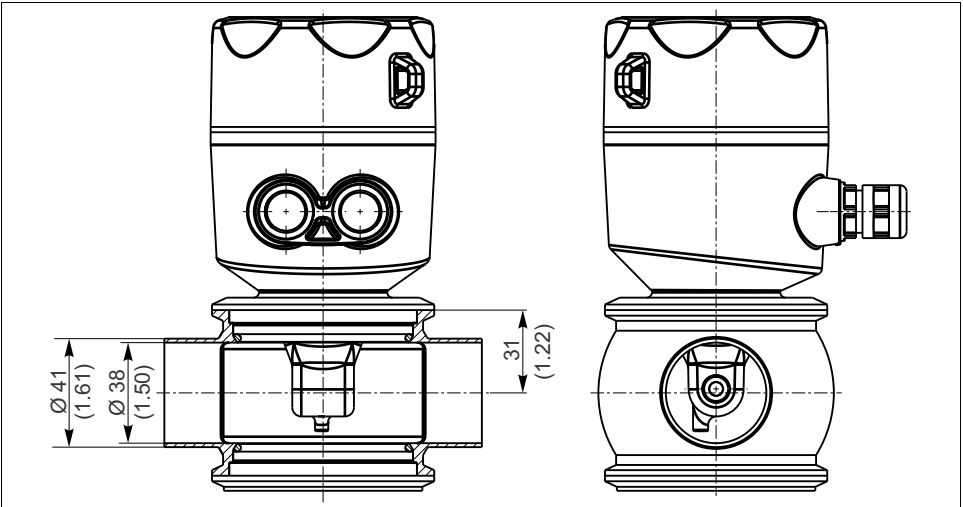

Fig. 7: Installation in DN 40 pipe with Varivent process connection, dimensions in mm (inch)

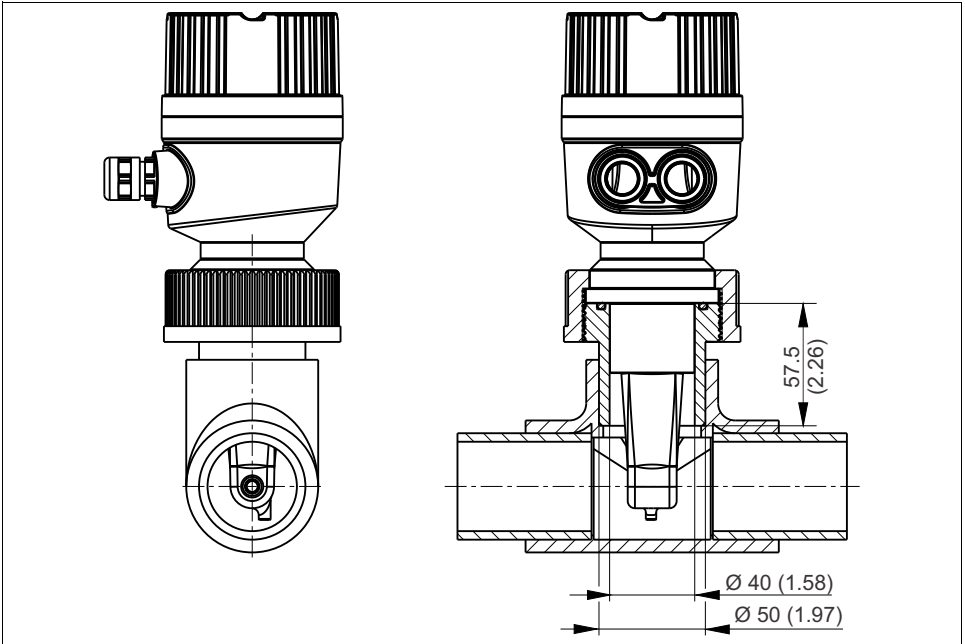

Fig. 8: Installation in DN 40 pipe with coupling nut 2 1/2" PVC process connection, dimensions in mm (inch)

4.2 Mounting the compact device

- i** Select a sensor installation depth such that the coil body is fully covered by the medium. Pay attention to the information concerning the distance between the sensor and the wall provided in the "Installation conditions" section.

Mount the compact device directly on a pipe nozzle or tank nozzle via the process connection. For the 1 1/2" threaded connection, use a Teflon tape to seal the connection and an adjustable pin wrench DIN 1810, flat face, size 45 to 50 mm to tighten it.

1. When installing, align the compact device in such a way that the medium flows through the flow opening of the sensor in the direction of medium flow. Use the arrow on the nameplate to help you align the device.
2. Tighten the flange.

4.3 Post-installation check

- After installation, check the compact device for damage.
- Ensure that the compact device is protected against direct sunlight

5 Electrical connection

⚠ WARNING

The device is live!

Incorrect wiring can result in injury or a fatality

- ▶ The electrical connection may only be established by an electrical technician.
- ▶ The electrical technician must have read and understood these Operating Instructions and must follow the instructions they contain.
- ▶ **Before beginning** the connection work, ensure that no voltage is applied to any of the cables.

5.1 Connecting the transmitter

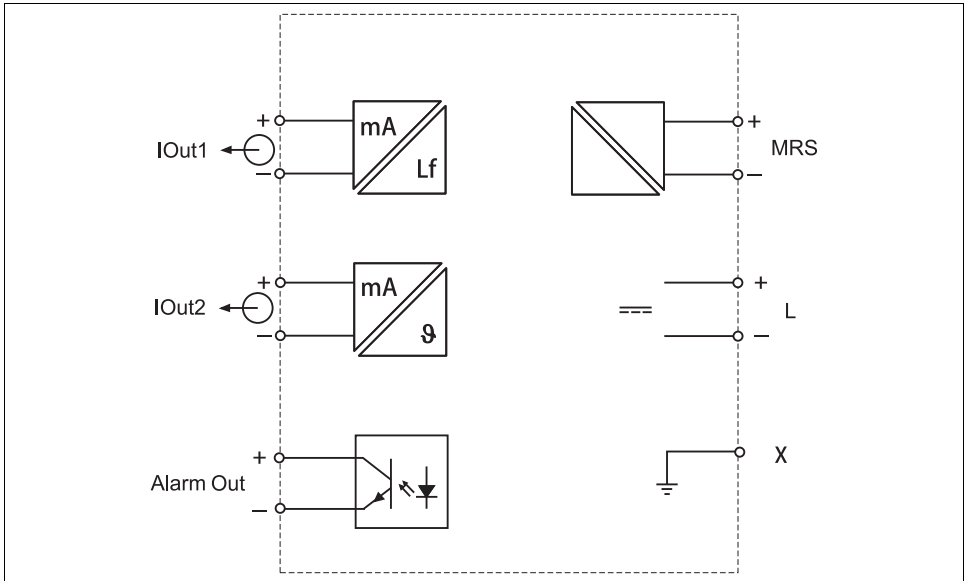
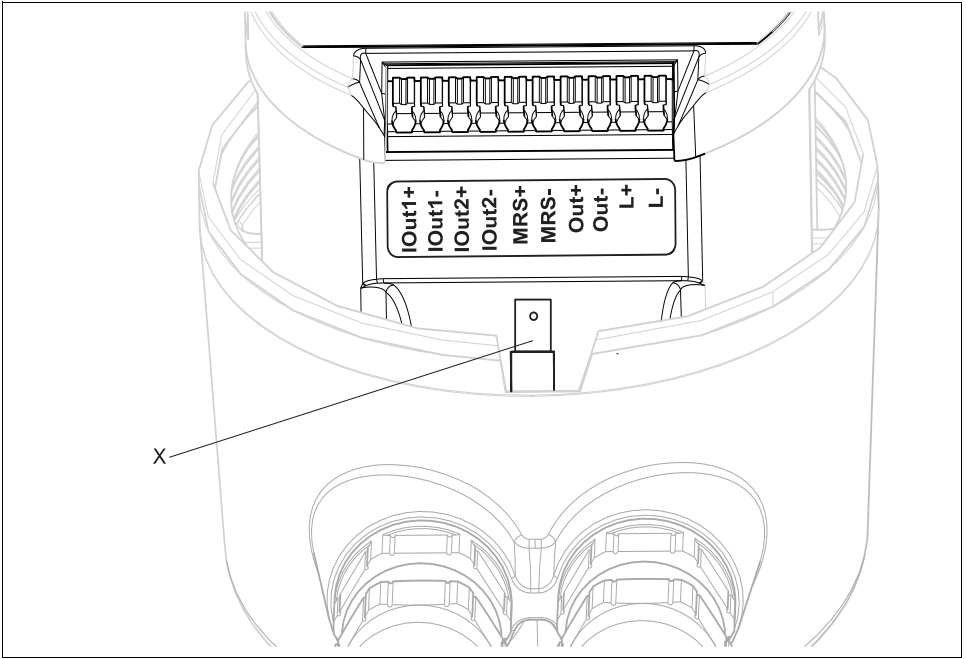

Fig. 9: Electrical connection

a0019115



a0019116

Fig. 10: Terminal assignment

<i>IOut1</i>	<i>Current output conductivity</i>
<i>IOut2</i>	<i>Current output temperature</i>
<i>MRS</i>	<i>Binary input (measuring range switch)</i>
<i>Out</i>	<i>Alarm output (open-collector)</i>
<i>L+/L-</i>	<i>Power supply</i>
<i>X</i>	<i>Grounding pin (flat male tab 4.8 mm)</i>



0.5 mm² is the recommended cable cross-section for the connecting cables. The maximum cable cross-section is 1.0 mm².

Connect the transmitter of the compact device as follows:

1. Unscrew the housing cover.
2. Guide the connecting cables through the cable glands.
3. Connect the cables as per the terminal assignment diagram.
4. Connect the protective ground to the terminal pin for the housing ground.

5.2 Guaranteeing the degree of protection

Guarantee the degree of protection as follows:

1. Check that the O-ring is seated correctly in the housing cover.
2. Screw down the housing cover as far as it will go.
3. Tighten the cable glands.

5.3 Post-connection check

Carry out the following checks after electrical connection:

Device condition and specifications	Notes
Are the transmitter and cables free from damage on the outside?	Visual inspection

Electrical connection	Notes
Are the installed cables strain-relieved and not twisted?	
Cable run without loops and cross-overs?	
Are the signal cables correctly connected as per the wiring diagram?	
Are all the cable entries installed, firmly tightened and leak-tight?	
Are the PE distributor rails grounded (if present)?	Grounding is at the place of installation

6 Operation options

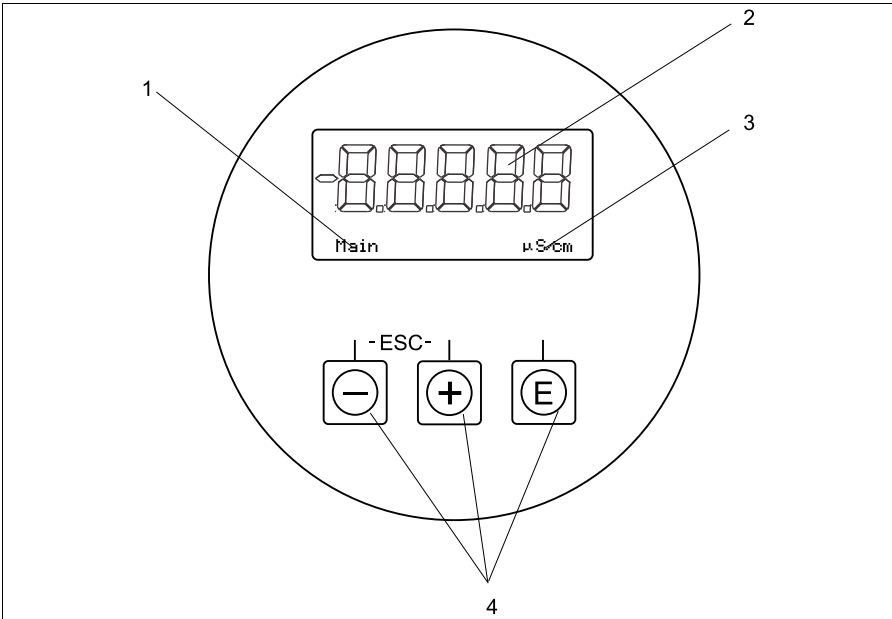

a0018963

Fig. 11: Display and operating keys

- 1 Parameter
- 2 Measured value
- 3 Unit
- 4 Operating keys

The LC display is split into two sections. The segment section displays the measured value. The dot-matrix section displays the parameter and unit. The operating texts are displayed in English. In the event of an error the device automatically alternates between displaying the error and the measured value.

Operating keys



- Open the Configuration menu
- Confirm the entry
- Select a parameter or submenu



Within the Configuration menu:

- Gradually select the menu items / characters for the parameter
- Change the selected parameter

Outside the Configuration menu

- Display enabled and calculated channels, as well as minimum and maximum values, for all the active channels.

Press both keys simultaneously (< 3 s) to quit the setup without saving any changes.

You can always quit menu items / submenus at the end of the menu via "x Back".

Symbols in the editing mode:

	Accept entry. If this symbol is selected, the entry is applied at the position specified by the user, and you quit the editing mode.
	Discard entry. If this symbol is selected, the entry is discarded and you quit the editing mode. The previously set text remains.
	Jump one position to the left. If this symbol is selected, the cursor jumps one position to the left.
	Delete backwards. If this symbol is selected, the character to the left of the cursor position is deleted.
	Delete all. If this symbol is selected, the entire entry is deleted.

The operating functions of the compact measuring device are divided into the following menus:

Display	Settings for the device display: contrast, brightness, time for alternating measured values on the display
Setup	Device settings
Calibration	Perform sensor calibration*
Diagnostics	Device information, diagnostics logbook, sensor information, simulation

* The air set and the correct cell constant have already been configured at the factory for Smartec CLD18 devices. Sensor calibration is not required.

7 Commissioning

7.1 Switching on the device

Familiarize yourself with the operation of the transmitter before switching it on. After power-up, the device performs a self-test and then switches to the measuring mode. If you are commissioning the device for the first time, program the setup as described in the following sections of these Operating Instructions.

7.2 Display settings (Display menu)

Press the 'E'-key to call up the main menu. The "Display" menu appears on the display. Press the 'E'-key again to open the menu. Use the "x Back" option, which can be found at the bottom of each menu, to move up a level in the menu structure.

Parameter	Possible settings	Description
Contrast	1 to 7 Default: 5	Setting for the contrast
Brightness	1 to 7 Default: 5	Setting for the brightness of the display
Alternating time	0, 3, 5, 10 s Default: 5	Alternating time between the two measured values 0 means that the values do not alternate on the display

7.3 Device configuration (Setup menu)

Press the 'E'-key to call up the main menu. Navigate through the available menus with the '+' and '-' keys. Press the 'E'-key to open the desired menu. Use the "x Back" option, which can be found at the bottom of each menu, to move up a level in the menu structure. Default settings are in bold.

Parameter	Possible settings	Description
Current range	4-20 mA 0-20 mA	Select the current range
Out1 0/4 mA	0 to 2000000 $\mu\text{S}/\text{cm}$ 0 $\mu\text{S}/\text{cm}$	Use this parameter to enter the measured value at which the minimum current value (0/4 mA) is present at the transmitter output.
Out1 20 mA	0 to 2000000 $\mu\text{S}/\text{cm}$ 0 $\mu\text{S}/\text{cm}$	Use this parameter to enter the measured value at which the maximum current value (20 mA) is present at the transmitter output.
Out2 0/4 mA	-50 to 250 $^{\circ}\text{C}$ 0.0 $^{\circ}\text{C}$	Use this parameter to enter the measured value at which the minimum current value (0/4 mA) is present at the transmitter output.
Out2 20 mA	-50 to 250 $^{\circ}\text{C}$ 100.0 $^{\circ}\text{C}$	Use this parameter to enter the measured value at which the maximum current value (20 mA) is present at the transmitter output.
Damping main	0 to 60 s 0 s	Damping value for the conductivity measured value
Extended setup		Extended settings The functions are described in the following section
Manual hold	Off , On	Function for freezing the current and alarm outputs

7.4 Extended setup (Extended Setup menu)

Press the 'E'-key to call up the main menu. Navigate through the available menus with the '+' and '-' keys. Press the 'E'-key to open the desired menu. Use the "x Back" option, which can be found at the bottom of each menu, to move up a level in the menu structure. Default settings are in bold.

Parameter	Possible settings	Description
System		General settings
Device tag	Customized text Max. 16 characters	Enter the device designation
Temp. unit	°C °F	Setting for the temperature unit
Hold release	0 to 600 s 0 s	Prolongs the device hold when the hold condition no longer applies
Alarm delay	0 to 600 s 0 s	Time that delays when an alarm is output. This suppresses alarm conditions that are present for a period that is shorter than the alarm delay time.
Input		Setting for the inputs
Cell const.	Read only	Displays the cell constant
Inst. factor	0.1 to 5.0 1.0	The affect of the distance from the wall can be corrected with the installation factor (see the "Installation factor" section).
Unit	auto , µS/cm, mS/cm	Unit of conductivity. "auto" automatically switches between µS/cm and mS/cm.
Damping main	0 to 60 s 0 s	Setting for the damping
Temp. comp.	Off , Linear	Setting for temperature compensation
T. comp. cal.	Off , Linear	Setting for temperature compensation during calibration
Alpha coeff.	1.0 to 20.0 %/K 2.1 %/K	Coefficient for linear temperature compensation

Parameter		Possible settings	Description
	Ref. temp	+10 to +50 °C 25 °C	Enter the reference temperature
	Process check		The process check checks the measuring signal for stagnation. An alarm is triggered if the measuring signal does not change over a certain period (several measured values).
	Function	On, Off	Switch the process check on or off
	Duration	1 to 240 min 60 min	The measured value must change within this time as otherwise an error message is triggered.
	Observation width	1 to 20 % 0.0 %	Bandwidth for the process check
Analog outputs			Setting for analog outputs
	Current range	4-20 mA 0-20 mA	Current range for analog output
	Out1 0/4 mA	0 to 2000000 µS/cm 0 µS/cm	Use this parameter to enter the measured value at which the minimum current value (0/4 mA) is present at the transmitter output.
	Out1 20 mA	0 to 2000000 µS/cm 0 µS/cm	Use this parameter to enter the measured value at which the maximum current value (20 mA) is present at the transmitter output.
	Out2 0/4 mA	-50 to 250 °C 0.0 °C	Use this parameter to enter the measured value at which the minimum current value (0/4 mA) is present at the transmitter output.
	Out2 20 mA	-50 to 250 °C 100.0 °C	Use this parameter to enter the measured value at which the maximum current value (20 mA) is present at the transmitter output.
MRS			Setting for measuring range switch (see the "MRS (measuring range switch)" section)
	Out1 0/4 mA	0 to 2000000 µS/cm 0 µS/cm	Use this parameter to enter the measured value at which the minimum current value (0/4 mA) is present at the transmitter output.
	Out1 20 mA	0 to 2000000 µS/cm 0 µS/cm	Use this parameter to enter the measured value at which the maximum current value (20 mA) is present at the transmitter output.

Parameter		Possible settings	Description
	Out2 0/4 mA	-50 to 250 °C 0.0 °C	Use this parameter to enter the measured value at which the minimum current value (0/4 mA) is present at the transmitter output.
	Out2 20 mA	-50 to 250 °C 100.0 °C	Use this parameter to enter the measured value at which the maximum current value (20 mA) is present at the transmitter output.
	Damping main	0 to 60 s 0 s	Setting for the damping
	Alpha coeff.	1.0 to 20 %/K 2.1 %/K	Coefficient for linear temperature compensation
Factory default			Factory settings
	Please confirm	no no, yes	

7.4.1 Installation factor

In confined installation conditions, the wall affects conductivity measurement in the liquid. The installation factor compensates for this effect. The cell constant is corrected by multiplying by the installation factor.

The value for the installation factor depends on the diameter and the conductivity of the pipe nozzle, as well as the distance between the wall and the sensor.

If there is a sufficient distance between the wall and the sensor ($a > 20 \text{ mm}$ (0.79"), from DN 60) the installation factor f does not need to be taken into consideration ($f = 1.00$).

If the distance from the wall is small, the installation factor increases for electrically insulating pipes ($f > 1$), and decreases for electrically conductive pipes ($f < 1$).

It can be measured using calibration solutions, or a close approximation can be determined from the following diagram.

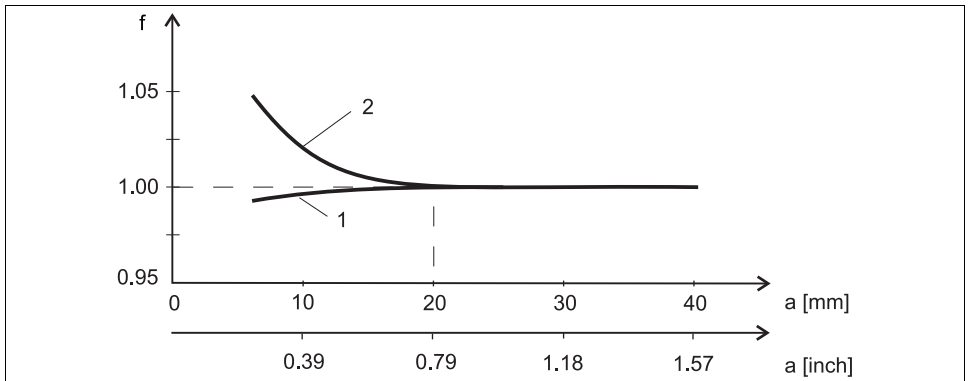

Fig. 12: Relationship between the installation factor (f) and the distance from wall (a)

- 1 Electrically conductive pipe wall
- 2 Electrically insulating pipe wall

7.4.2 Temperature compensation

The conductivity of a liquid depends heavily on the temperature, as the mobility of the ions and the number of dissociated molecules are temperature-dependent. In order to compare measured values, they must be referenced to a defined temperature. The reference temperature is 25 °C (77 °F).

The temperature is always specified when the conductivity is specified. $k(T_0)$ represents the conductivity measured at 25 °C (77 °F) or referenced back to 25 °C (77 °F).

The temperature coefficient α represents the percentage change in the conductivity per degree of temperature change. The conductivity k at the process temperature is calculated as follows:

$$\kappa(T) = \kappa(T_0) \cdot (1 + \alpha \cdot (T - T_0))$$

where

$k(T)$ = conductivity at process temperature T

$k(T_0)$ = conductivity at process temperature T_0

The temperature coefficient depends on both the chemical composition of the solution and on the temperature, and is between 1 and 5 % per °C. The electrical conductivity of the majority of diluted saline solutions and natural waters changes in a close-to-linear fashion.

Typical values for the temperature coefficient α :

Natural waters	approx. 2 %/K
Salts (e.g. NaCl)	approx. 2.1 %/K
Alkalis (e.g. NaOH)	approx. 1.9 %/K
Acids (e.g. HNO ₃)	approx. 1.3 %/K

7.4.3 Measuring range switch (MRS)

Measuring range switching involves a parameter set changeover for two substances:

- in order to cover a large measuring range
- in order to adjust temperature compensation in the event of a product change

The two analog outputs can each be configured with two parameter sets.

- Parameter set 1:

The parameters for the current outputs and the damping can be set in the Setup menu.

The alpha coefficient for temperature compensation can be set in the Setup/Extended Setup/Input menu.

Parameter set 1 is active if the "MRS" signal input is **LOW**.

- Parameter set 2:

The parameters for the current outputs, the damping and the alpha coefficient for

temperature compensation can be set in the Setup/Extended Setup/Remote Switch menu.

Parameter set 2 is active if the "Remote switch" signal input is **HIGH**.



The settings for parameter set 1 are also listed in the Extended Setup/Analog Outputs menu.

The LOW and HIGH specifications are described in the "Technical data" section.

7.5 Calibration (Calibration menu)

The air set and the correct cell constant have already been configured at the factory for Smartec CLD18 devices. Sensor calibration is not required.

7.5.1 Types of calibration

The following types of calibration are possible:

- Cell constant with calibration solution
- Airset (residual coupling)

7.5.2 Cell constant

General information

A conductivity measuring system is generally calibrated in such a way that the exact cell constant is determined or checked using suitable calibration solutions. This process is described in the standards EN 7888 and ASTM D 1125, for example, and the method for producing a number of calibration solutions is explained.

Calibrating the cell constant

 You enter a reference value for the conductivity with this type of calibration. In addition, you specify how the system should compensate for the influence of temperature. In the result, the device calculates a new cell constant for the sensor.

1. Go to the "CAL"/"Cell constant" menu.
2. Work your way through the menu functions that follow.
3. Start the calibration.

Path: CAL/Conductivity/Cell constant

Function	Options	Info
Current cell const.	Read only	Value currently saved in the sensor
Temp. compensation	Options <ul style="list-style-type: none"> ■ No ■ Yes Factory setting Yes	As an alternative to the compensated conductivity (Yes) you can also determine the cell constant by calibrating the uncompensated conductivity (No).
Coeff. Alpha	0.00 to 20.00 %/K Factory setting Depends on the sensor	<i>Temp. compensation = "Yes"</i> The alpha coefficients and alpha reference temperatures of Endress+Hauser can be found in the documentation supplied with the calibration solutions. Enter the appropriate values.
Alpha ref. temp.	-5.0 to 100.0 °C (23.0 to 212.0 °F) Factory setting 25.0 °C (77.0 °F)	
Temp. source	Options <ul style="list-style-type: none"> ■ Sensor ■ Manual Factory setting Sensor	Decide how you want to compensate the medium temperature: <ul style="list-style-type: none"> ■ Automatically using the temperature sensor of your sensor ■ Manually by entering the medium temperature
Medium temperature	-50.0 to 250.0 °C (-58.0 to 482.0 °F) Factory setting 25.0 °C (77 °F)	<i>Temp. source = "Manual"</i> Enter the temperature of your medium.
Conductivity ref	0.000 to 2000000 µS/cm Factory setting 0.000 µS/cm	<i>Temp. compensation = "Yes"</i> Enter the compensated conductivity of your calibration solution here. <i>Temp. compensation = "No"</i> Enter the uncompensated conductivity of your calibration solution here.
 Start calibration	Start the calibration. Follow the instructions on the display.	

You can cancel the calibration any time by pressing the "ESC" key. No new data are then used to adjust the sensor.

7.5.3 Airset (residual coupling)

While the calibration line goes through zero for physical reasons in the case of conductive sensors (a current flow of 0 corresponds to a conductivity of 0), when working with inductive sensors, the residual coupling between the primary coil (transmitter coil) and secondary coil (receiver coil) must be taken into account or compensated for. The residual coupling is not only caused by the direct magnetic coupling of the coils but also by crosstalk in the supply cables. For this reason, the process of commissioning an inductive sensor always starts with an "air set". Here, the sensor is connected to the device with the cables provided, held in air in a dry state (zero conductivity) and an air set calibration is performed at the transmitter. The cell constant is then determined using a precise calibration solution, as is the case with the sensors.

8 Diagnostics and troubleshooting

8.1 Device diagnostics (Diagnostics menu)

Press the 'E'-key to call up the main menu. Navigate through the available menus with the '+' and '-' keys. Press the 'E'-key to open the desired menu. Use the "x Back" option, which can be found at the bottom of each menu, to move up a level in the menu structure.

Parameter	Possible settings	Description
Current diag.	Read only	Displays the current diagnostic message
Last diag	Read only	Displays the last diagnostic message
Diagnost logbook	Read only	Displays the last diagnostic messages
Device info	Read only	Displays device information
Sensor info	Read only	Displays sensor information
Simulation		
Analog out 1	Off 0 mA, 3.6 mA, 4 mA, 10 mA, 12 mA, 20 mA, 21 mA	Outputs a corresponding value at "analog out 1".
Analog out 2	Off 0 mA, 3.6 mA, 4 mA, 10 mA, 12 mA, 20 mA, 21 mA	Outputs a corresponding value at "analog out 2".
Alarm out	Off Active Inactive	
Reset device		

8.2 Troubleshooting instructions

Display	Cause	Remedial action
No measured value displayed	No power supply connected	Check the power supply of the device.
	Power is supplied, device is defective	The device must be replaced.
Diagnostic message is displayed	The list of diagnostic messages is provided in the following section	

8.3 Diagnostic messages

The diagnostic message consists of a diagnostic code and a message text. The diagnostic code is made up of the error category as per Namur NE 107 and the message number.

Error category (letter in front of the message number)

- F = Failure. A malfunction has been detected.

The measured value of the affected channel is no longer reliable. The cause of the malfunction is to be found in the measuring point. Any controller connected should be set to manual mode.

- M = Maintenance required. Action may have to be taken soon.

The device still measures correctly. Immediate measures must not be taken. However, proper maintenance efforts would prevent a possible malfunction in the future.

- C = Function check, waiting (no error)

Maintenance work is being performed on the device. Wait until the work has been completed.

- S = Out of specification. The measuring point is being operated outside specifications.

Operation is still possible. However, you run the risk of increased wear, shorter operating life or lower accuracy levels. The cause of the problem is to be found outside the measuring point.

Diagnostic code	Message text	Description
F61	Sensor elec.	Sensor electronics defective Remedial action: <ul style="list-style-type: none"> ■ Contact the Service Department
F62	Sens. connect	Sensor connection Remedial action: <ul style="list-style-type: none"> ■ Contact the Service Department
F100	Sensor comm.	Sensor not communicating Possible reasons: <ul style="list-style-type: none"> ■ No sensor connection Remedial action: <ul style="list-style-type: none"> ■ Contact the Service Department
F130	Sensor supply	Sensor check Faulty sensor power supply Remedial action: <ul style="list-style-type: none"> ■ Contact the Service Department
F142	Sensor signal	Sensor check No conductivity displayed Possible reasons: <ul style="list-style-type: none"> ■ Sensor in air ■ Sensor defective Remedial action: <ul style="list-style-type: none"> ■ Check sensor installation ■ Contact the Service Department
F143	Self-test	Sensor self-test error Remedial action: <ul style="list-style-type: none"> ■ Contact the Service Department

Diagnostic code	Message text	Description
F152	No airset	Sensor data No calibration data available Remedial action: <ul style="list-style-type: none"> ▪ Perform an air set
F523	Cell const.	Sensor calibration warning Invalid cell constant, max. range reached Remedial action: <ul style="list-style-type: none"> ▪ Enter cell constant as per factory specifications ▪ Contact the Service Department
F524	Cell const.	Sensor calibration warning Min. possible cell constant is undershot Remedial action: <ul style="list-style-type: none"> ▪ Enter cell constant as per factory specifications ▪ Contact the Service Department
F845	Device ID	Incorrect hardware configuration
F847	Couldn't save param	Parameter incorrect
F848	Calib AO1	Incorrect calibration values for analog output 1
F849	Calib AO2	Incorrect calibration values for analog output 2
F904	Process check	Process check system alarm Measuring signal has not changed for a long time Possible reasons: <ul style="list-style-type: none"> ▪ Contaminated sensor, or sensor in air ▪ No flow to sensor ▪ Sensor defective ▪ Software error Remedial action: <ul style="list-style-type: none"> ▪ Check measuring chain ▪ Check sensor ▪ Restart device

Diagnostic code	Message text	Description
C107	Calib. active	Sensor calibration is active Remedial action: <ul style="list-style-type: none"> ▪ Wait for calibration to be finished
C154	No calib. data	Sensor data No calibration data available, factory settings are used Remedial action: <ul style="list-style-type: none"> ▪ Check the calibration information of the sensor ▪ Contact the Service Department
C850	Simu AO1	Simulation of analog output 1 is active
C851	Simu AO2	Simulation of analog output 2 is active

Diagnostic code	Message text	Description
S844	Process value	<p>Measured value outside the specified range</p> <p>Possible reasons:</p> <ul style="list-style-type: none"> ■ Sensor in air ■ Incorrect flow to sensor ■ Sensor defective <p>Remedial action:</p> <ul style="list-style-type: none"> ■ Increase the process value ■ Check measuring chain

Diagnostic code	Message text	Description
M500	Not stable	<p>Sensor calibration aborted</p> <p>Main measured value fluctuating</p> <p>Possible reasons:</p> <ul style="list-style-type: none"> ■ Sensor in air ■ Sensor contaminated ■ Incorrect flow to sensor ■ Sensor defective <p>Remedial action:</p> <ul style="list-style-type: none"> ■ Check sensor ■ Check installation
M526	Cell const.	<p>Sensor calibration warning</p> <p>Invalid cell constant, max. range reached</p> <p>Remedial action:</p> <ul style="list-style-type: none"> ■ Recalibrate ■ Enter cell constant as per factory specifications ■ Contact the Service Department
M528	Cell const.	<p>Sensor calibration warning</p> <p>Min. possible cell constant is undershot</p> <p>Remedial action:</p> <ul style="list-style-type: none"> ■ Recalibrate ■ Enter cell constant as per factory specifications ■ Contact the Service Department

9 Maintenance

▲ WARNING

Risk of injury if medium escapes!

- ▶ Before performing any maintenance work, make sure that the process pipe is unpressurized, empty and has been rinsed.

9.1 Cleaning the housing

Only clean the front of the housing with commercially available cleaning agents.

The front is resistant to the following as per DIN 42 115:

- Ethanol (short periods)
- Diluted acids (max. 2% HCl)
- Diluted bases (max. 3% NaOH)
- Soap-based household cleaners

NOTICE

Prohibited cleaning agents

Danger of damaging the housing surface or housing sealing.

- ▶ Never use concentrated mineral acids or bases for cleaning purposes.
- ▶ Never use organic cleaners such as benzyl alcohol, methanol, methylene chloride, xylene or concentrated glycerol cleaner.

10 Repair

The O-ring is defective if medium escapes from the leakage hole. Contact the E+H Service Department to replace the O-ring.

10.1 Return

The product must be returned if repairs or a factory calibration are required, or if the wrong product has been ordered or delivered. According to legal regulations Endress+Hauser, as an ISO-certified company, is required to follow certain procedures when handling returned products that are in contact with the medium.

To ensure swift, safe and professional device returns:

Check the website for information about the return procedure and basic conditions

www.services.endress.com/return-material

10.2 Disposal

Electronic components are used in the product. For this reason, the product must be disposed of as electronic waste.

Please observe local regulations.

11 Accessories

 The most important accessories available at the time this document went to print are listed below. Contact your local Service Center or Sales Center for accessories that are not listed here.

11.1 Standard solutions

Precision solutions referenced to the NIST standard reference material (SRM) for the qualified calibration of conductivity measuring systems as per ISO 9000, with temperature table

- CLY11-C
1.406 mS/cm (reference temperature 25 °C (77 °F)), 500 ml (16.9 fl.oz)
Order No. 50081904
- CLY11-D
12.64 mS/cm (reference temperature 25 °C (77 °F)), 500 ml (16.9 fl.oz)
Order No. 50081905
- CLY11-E
107.0 mS/cm (reference temperature 25 °C (77 °F)), 500 ml (16.9 fl.oz)
Order No. 50081906

12 Technical data

12.1 Input

12.1.1 Measured variables

Conductivity

Temperature

12.1.2 Measuring range

Conductivity Recommended range: 200 $\mu\text{S}/\text{cm}$ to 1000 mS/cm
(uncompensated)

Temperature -10 to +130 °C (+14 to +266 °F)

12.1.3 Temperature measurement

Pt 1000

12.1.4 Binary input

The binary input is used for measuring range switching.

Voltage range	0 V to 30 V
Voltage HIGH min.	12 V
Voltage LOW max.	9.0 V
Current consumption at 24 V	30 mA
Undefined voltage range	9.0 to 12 V

12.2 Output

12.2.1 Output signal

Conductivity	0/4 to 20 mA, galvanically isolated
Temperature	0/4 to 20 mA, galvanically isolated

12.2.2 Load

Max. 500 Ω

12.2.3 Characteristic

Linear

12.2.4 Signal resolution

Resolution	> 13 bit
Accuracy	$\pm 20 \mu\text{A}$

12.3 Power supply

12.3.1 Supply voltage

24 V DC $\pm 20\%$, protected against reverse polarity

12.3.2 Power consumption

3 W

12.3.3 Cable specification

Recommended	0.5 mm ²
Max.	1.0 mm ²

12.4 Performance characteristics

12.4.1 Response time

Conductivity	$t_{95} < 2 \text{ s}$
Temperature	$t_{90} < 50 \text{ s}$

12.4.2 Measured error

Conductivity	$\pm (2.0 \% \text{ of measured value} + 20 \text{ } \mu\text{S/cm})$
Temperature	$\pm 1.5 \text{ K}$
Signal outputs	$\pm 50 \text{ } \mu\text{A}$

12.4.3 Repeatability

Conductivity	Max. $0.5 \% \text{ of measured value} \pm 5 \text{ } \mu\text{S/cm} \pm 2 \text{ digits}$
--------------	--

12.4.4 Cell constant

11.0 cm^{-1}

12.4.5 Temperature compensation

Range	$-10 \text{ to } +130 \text{ } ^\circ\text{C}$ ($+14 \text{ to } +266 \text{ } ^\circ\text{F}$)
Types of compensation	- none - linear with freely configurable temperature coefficients

12.4.6 Reference temperature

$25 \text{ } ^\circ\text{C}$ ($77 \text{ } ^\circ\text{F}$)

12.5 Environment

12.5.1 Ambient temperature range

Stainless steel process connection: -20 to +60 °C (-4 to +140 °F)

PVC process connection: -10 to +60 °C (14 to 140 °F)

12.5.2 Storage temperature

Stainless steel process connection: -25 to +80 °C (-13 to +176 °F)

PVC process connection: -10 to +60 °C (14 to 140 °F)

12.5.3 Relative humidity

≤ 100%, condensating

12.5.4 Climate class

Climate class 4K4H as per EN 60721-3-4

12.5.5 Degree of protection

IP 69k as per EN 40050:1993

Degree of protection NEMA TYPE 6P as per NEMA 250-2008

12.5.6 Shock resistance

Complies with IEC 61298-3, certified up to 5 g

12.5.7 Vibration resistance

Complies with IEC 61298-3, certified up to 5 g

12.5.8 Electromagnetic compatibility

Interference emission as per EN 61000-6-3:2007 + A1:2011 and EN 55011:2009 + A1:2010

Interference immunity as per EN 61326-1:2006

12.6 Process

12.6.1 Process temperature range

Stainless steel process connection:

-10 to +110 °C (14 to 230 °F)

Max.130 °C (266 °F) up to 60 minutes

PVC process connection:

-10 to +60 °C (14 to 140 °F)

12.6.2 Process pressure

Stainless steel process connection:

12 bar (174 psi) up to 50 °C (122 °F)

6.75 bar (98 psi) at 110 °C (230 °F)

5.0 bar (72.5 psi) at 130 °C (266 °F) max. 60 minutes

PVC process connection:

8 bar (116 psi) up to 50 °C (122 °F)

5.0 bar (72.5 psi) at 60 °C (140 °F)

12.6.3 Pressure-temperature ratings

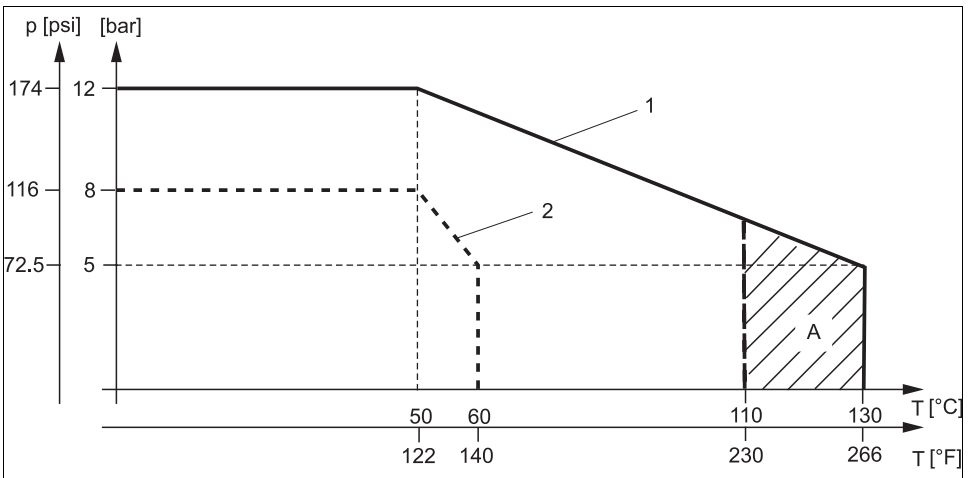

Fig. 13: Pressure-temperature ratings

1 Stainless steel process connection

2 PVC process connection

A Process temperature increased briefly (max. 60 minutes)

12.6.4 Flow velocity

Max. 5 m/s (16.4 ft/s) for low-viscosity media in pipe DN 50

12.7 Mechanical construction

12.7.1 Dimensions

See the "Installation" section

12.7.2 Weight

Stainless steel housing:	up to 1.870 kg (4.12 lbs)
Plastic housing:	up to 1.070 kg (2.36 lbs)

12.7.3 Material

In contact with medium

Sensor:	PEEK (polyetheretherketone)
Process connection:	Stainless steel 1.4435 (AISI 316 L), PVC-U
Seal:	EPDM

Not in contact with medium

Stainless steel housing:	Stainless steel 1.4308 (ASTM CF-8, AISI 304)
Plastic housing:	PBT GF20
Seals:	EPDM
Window:	PC
Cable glands:	PA, TPE

Index

A

Airset 30
Approvals 7

C

Calibration 28
Cell constant 28
Certificates 7

D

Degree of protection 16
Designated use 4
Diagnostic messages 33
Display elements 17
Disposal 37

E

Electrical connection 14
Electrical technician 14
Elements 8
Error codes 33
Extended setup 22

I

Incoming acceptance 6
Installation 13
Installation conditions 9
Installation factor 25

M

Maintenance 36
Measuring range switch 27
Menu
 Calibration 28
 Diagnostics 31
 Display 20
 Extended Setup 22
 Setup 21
Mounting 13
MRS 27

N

Nameplate 6

O

Occupational safety 4
Operating elements 17
Operational safety 5

P

Post-connection check 16
Power-up 20
Product description 8
Product identification 6
Product safety 5

R

Requirements for personnel 4
Return 37

S

Safety instructions 4
Scope of delivery 6
Service 36
Setup 21

T

Technical data 39
Temperature compensation 26
Troubleshooting instructions 32
Types of calibration 28

W

Wiring 14



71264816

www.addresses.endress.com
