

Operating Instructions

Flowfit CUA262

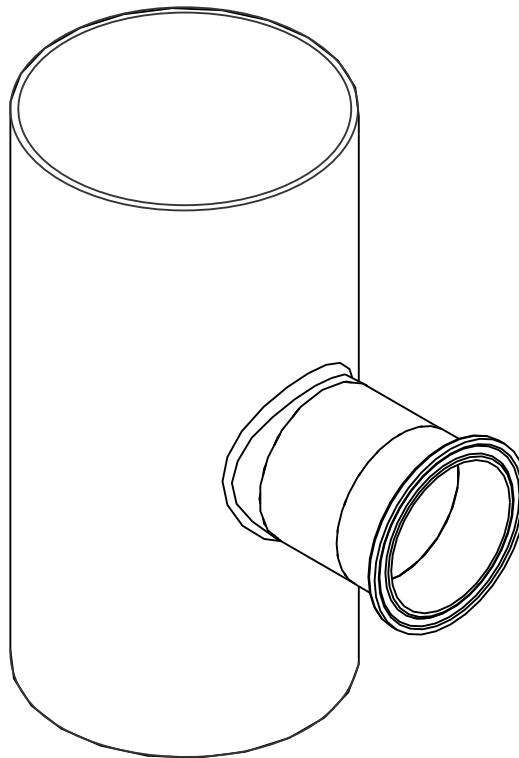



Flow assembly for CUS52D turbidity sensor



Document information

Warnings

The structure, signal words and safety colors of the signs comply with the specifications of ANSI Z535.6 ("Product safety information in product manuals, instructions and other collateral materials").

Safety message structure	Meaning
 DANGER Causes (/consequences) Consequences if safety message is not heeded ▶ Corrective action	This symbol alerts you to a dangerous situation. Failure to avoid the situation will result in a fatal or serious injury.
 WARNING Causes (/consequences) Consequences if safety message is not heeded ▶ Corrective action	This symbol alerts you to a dangerous situation. Failure to avoid the situation can result in a fatal or serious injury.
 CAUTION Causes (/consequences) Consequences if safety message is not heeded ▶ Corrective action	This symbol alerts you to a dangerous situation. Failure to avoid this situation can result in minor or more serious injuries.
 NOTICE Cause/situation Consequences if safety message is not heeded ▶ Action/note	This symbol alerts you to situations that can result in damage to property and equipment.

Symbols





-  Additional information, tips
-  Permitted or recommended
-  Forbidden or not recommended

Table of contents

1	Basic safety instructions	4
1.1	Requirements for personnel	4
1.2	Designated use	4
1.3	Occupational safety	4
1.4	Operational safety	4
1.5	Product safety	5
2	Incoming acceptance and product identification	6
2.1	Incoming acceptance	6
2.2	Product identification	6
2.3	Scope of delivery	6
2.4	Certificates and approvals	6
3	Installation	7
3.1	Dimensions	7
3.2	Installation conditions	7
3.3	Installation instructions	10
3.4	Sensor installation	11
3.5	Post-installation check	11
4	Commissioning	12
5	Maintenance	13
5.1	Cleaning the assembly	13
5.2	Cleaning the sensor	13
5.3	Cleaning agent	14
5.4	Checking and replacing the seal	14
6	Repair	15
6.1	Spare parts kits	15
6.2	Return	15
6.3	Disposal	15
7	Accessories	16
7.1	Connection accessories	16
8	Technical data	17
8.1	Environment	17
8.2	Process	17
8.3	Mechanical construction	17
	Index	18

1 Basic safety instructions

1.1 Requirements for personnel

- ▶ Installation, commissioning, operation and maintenance of the measuring system must only be carried out by specially trained technical personnel.
 - ▶ The technical personnel must be authorized for the specified activities by the system operator.
 - ▶ Electrical connection must only be carried out by a certified electrician.
 - ▶ Technical personnel must have read and understood these Operating Instructions and must adhere to them.
 - ▶ Faults at the measuring point may only be rectified by authorized and specially trained personnel.
-  Repairs not described in the enclosed Operating Instructions may only be carried out directly at the manufacturer's or by the service organization.

1.2 Designated use

The CUA262 flow assembly is designed for the installation of the CUS52D turbidity sensor.

Its main areas of application are:

- Turbidity measurement at all stages of the process in skids for water treatment
- Turbidity measurement in closed piping systems (stainless steel)
- Turbidity check in filter modules

Any other use than the one described here compromises the safety of persons and the entire measuring system and is therefore not permitted.

The manufacturer is not liable for damage resulting from improper or non-designated use.

1.3 Occupational safety

As the user, you are responsible for complying with the following safety conditions:

- Explosion protection guidelines (only devices approved for use in explosion hazardous areas)
- Installation instructions
- Local prevailing standards and regulations

Electromagnetic compatibility

This device has been tested for electromagnetic compatibility in accordance with the applicable European standards for industrial applications.

The electromagnetic compatibility indicated only applies to a device that has been connected in accordance with the instructions in these Operating Instructions.

1.4 Operational safety

- ▶ Before commissioning the entire measuring point, make sure all the connections are correct. Ensure that electrical cables and hose connections are not damaged.
- ▶ Do not operate damaged products, and secure them against unintentional commissioning. Label and identify the damaged product as defective.
- ▶ If faults cannot be rectified, you must take the products out of service and secure them against unintentional commissioning.

1.5 Product safety

The product is designed to meet state-of-the-art safety requirements, has been tested and left the factory in a condition in which it is safe to operate.

Relevant regulations and European standards have been observed.

2 Incoming acceptance and product identification

2.1 Incoming acceptance

- Make sure the packaging is undamaged!
- Notify the supplier of any damage to the packaging. Keep the damaged packaging until the matter has been settled.
- Make sure the contents are not damaged!
- Notify the supplier of any damage to the delivery contents. Keep the damaged products until the matter has been settled.
- Check the delivery to make sure nothing is missing. Compare it against the shipping documents and your order.
- Pack the product for storage and transportation in such a way that it is reliably protected against impact and moisture. The original packaging offers the best protection. Furthermore, the permitted ambient conditions must also be observed (see "Technical data").
- If you have any questions, contact your supplier or your local sales center.

2.2 Product identification

2.2.1 Nameplate

You can find the following information on the nameplate:

- Manufacturer details
- Order code
- Extended order code
- Serial number
- Operating conditions
- Safety information symbols

Compare the order code on the nameplate with your order.

2.2.2 Identifying the product

The order code and serial number of your device can be found in the following locations:

- On the nameplate
- In the shipping documents

 To discover what product version you have, enter the order code on the nameplate into the search screen at the following address:
www.products.endress.com/order-ident

2.3 Scope of delivery

The scope of delivery comprises:

- 1 Flowfit CUA262 flow assembly in the version ordered
- 1 Set of Operating Instructions BA01299C/07/EN

If you have any questions, contact your supplier or your local sales center.

2.4 Certificates and approvals

Declaration of Conformity

The product meets the requirements of the harmonized European standards.

As such, it complies with the legal specifications of the EC directives.

The manufacturer confirms successful testing of the product by affixing to it the **CE** mark.

3 Installation

3.1 Dimensions

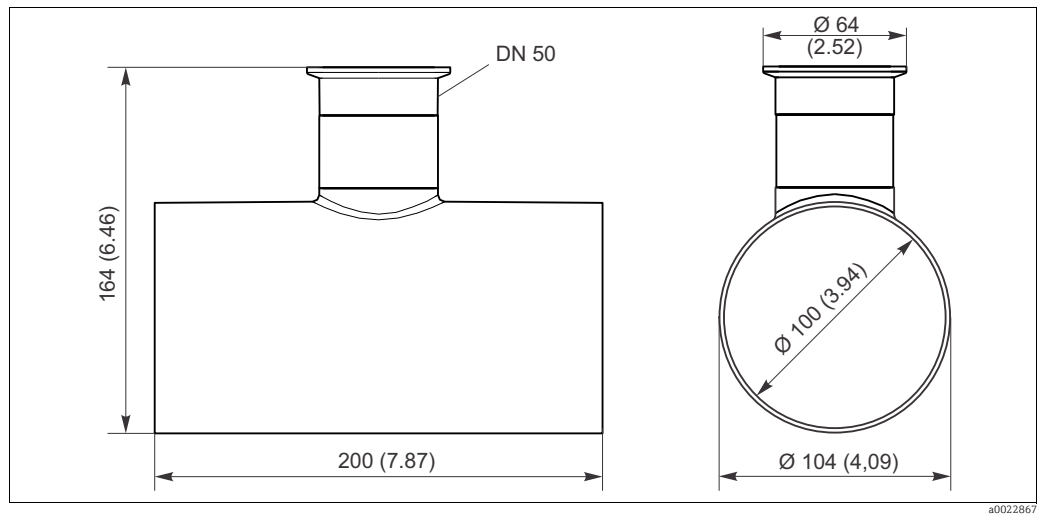

Fig. 1: Dimensions in mm (inch)

3.2 Installation conditions

Installation in the process pipe

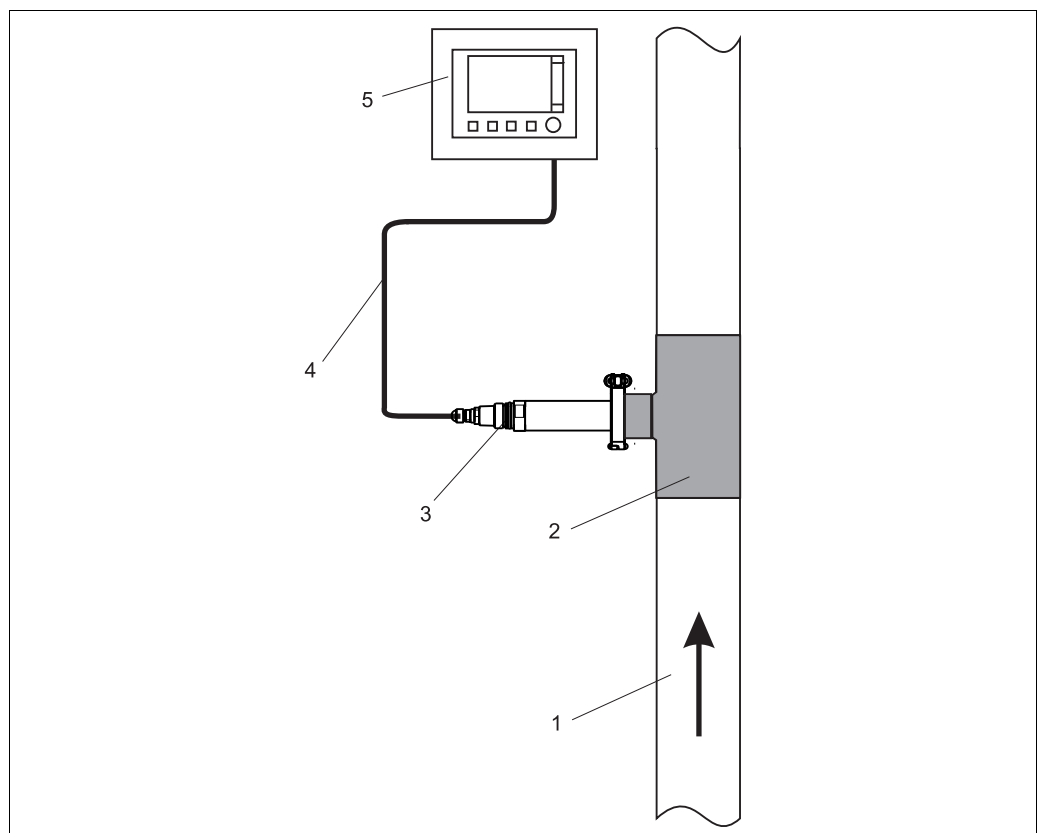

Fig. 2: Installation in the process pipe

- 1 Flow direction
- 2 Flowfit CUA262 flow assembly
- 3 CUS52D sensor
- 4 Measuring cable
- 5 Liquiline CM4442 transmitter

To ensure that medium flows through the assembly in a bypass configuration, the pressure p_1 must be greater than the pressure p_2 . This is achieved by installing an orifice plate in the main pipe.

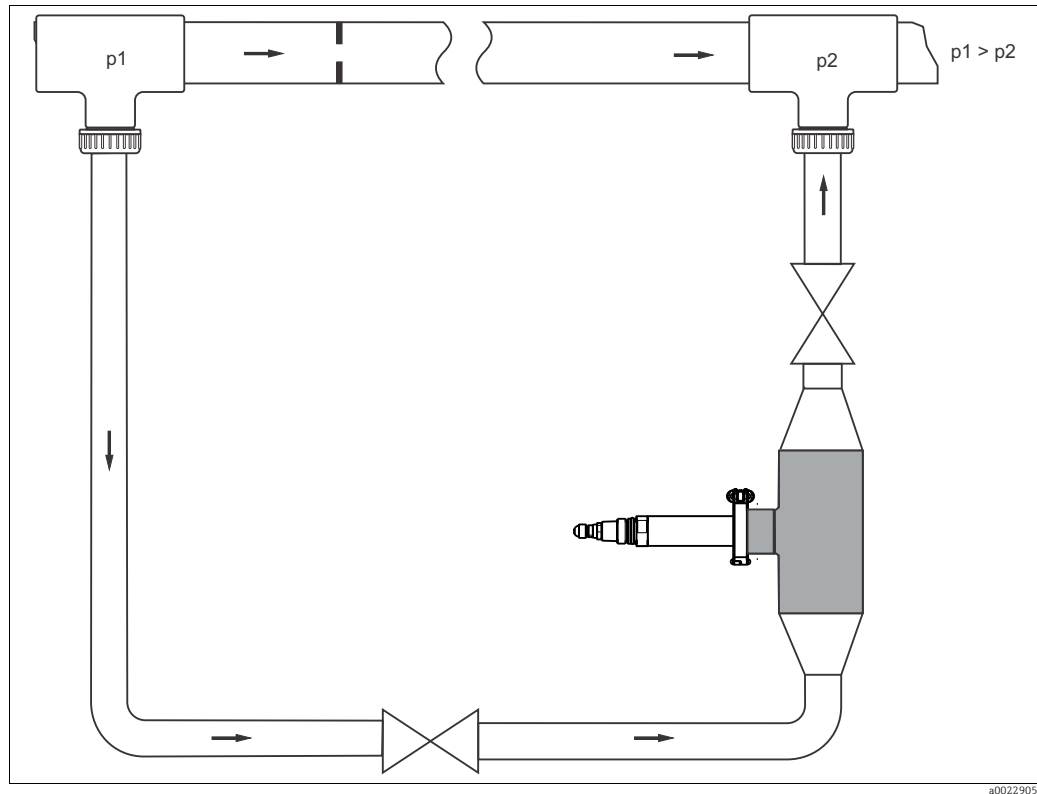

Fig. 3: Connection example involving a bypass and an orifice plate in the main pipe (supply from below)

The inlet and outlet connection of the flow assembly are always identical, the system is symmetrical.

Install the flow assembly vertically.

The supply must be connected at the bottom (upward flow in the pipe).

i Pay attention to the installation instructions (flow direction) for the sensor.

Wall effects:

Backscattering on the pipe wall may result in the distortion of measurement values in the case of turbidity values < 200 FNU. It is recommended that you adjust the installation. Black plastic pipes with diameter $> \text{DN } 60$ exhibit hardly any wall effects (< 0.05 FNU). For this reason, the use of black plastic pipes is recommended.

Additional information on avoiding wall effects:

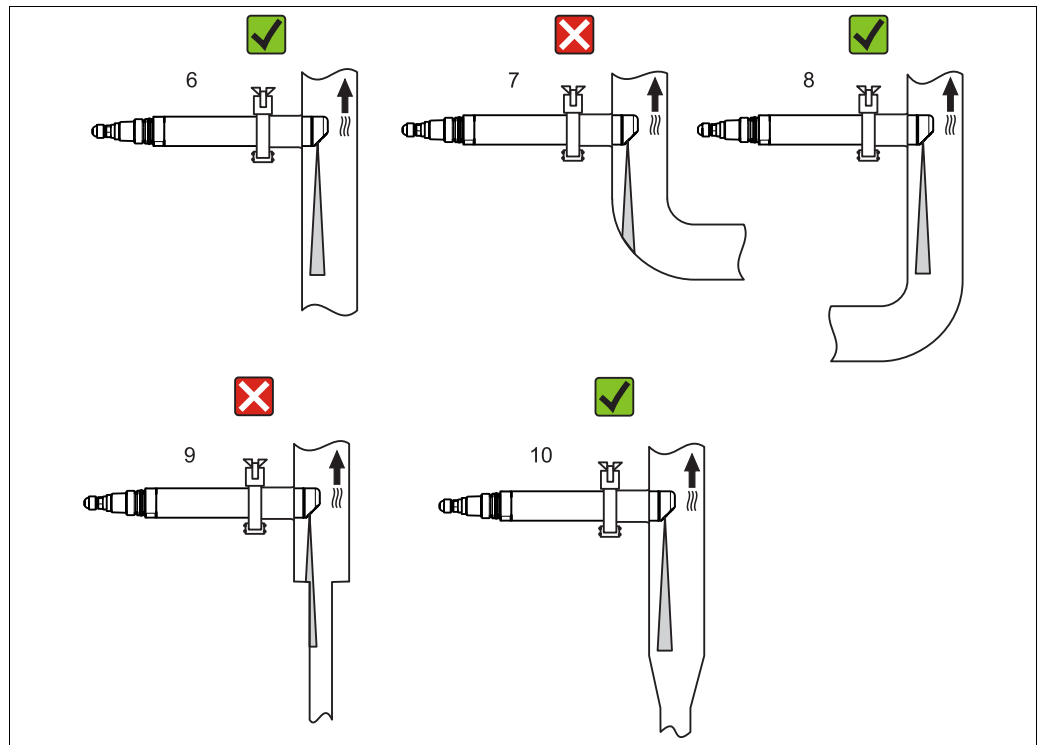

Fig. 4: Orientations for pipes and assemblies

- Install the sensor in such a way that the light beam is not reflected (pos. 6).
- Avoid sudden changes in cross-section (pos. 9). Changes in cross-section should be gradual and located as far away as possible from the sensor (pos. 10).
- Do not install the sensor directly downstream from a bend (pos. 7). Instead position it as far away as possible from the bend (pos. 8).
- When using reflective materials (e.g. stainless steel), the pipe diameter must be at least 100 mm (4"). It is recommended that the installation be adjusted on site.
- Pipes made of stainless steel with diameter >DN 300 exhibit hardly any wall effects.

3.3 Installation instructions

3.3.1 Measuring system

A complete measuring system consists of:

- Flowfit CUA262 flow assembly
- Turbimax CUS52D sensor
- Transmitter, e.g. Liquiline CM442
- Measuring cable

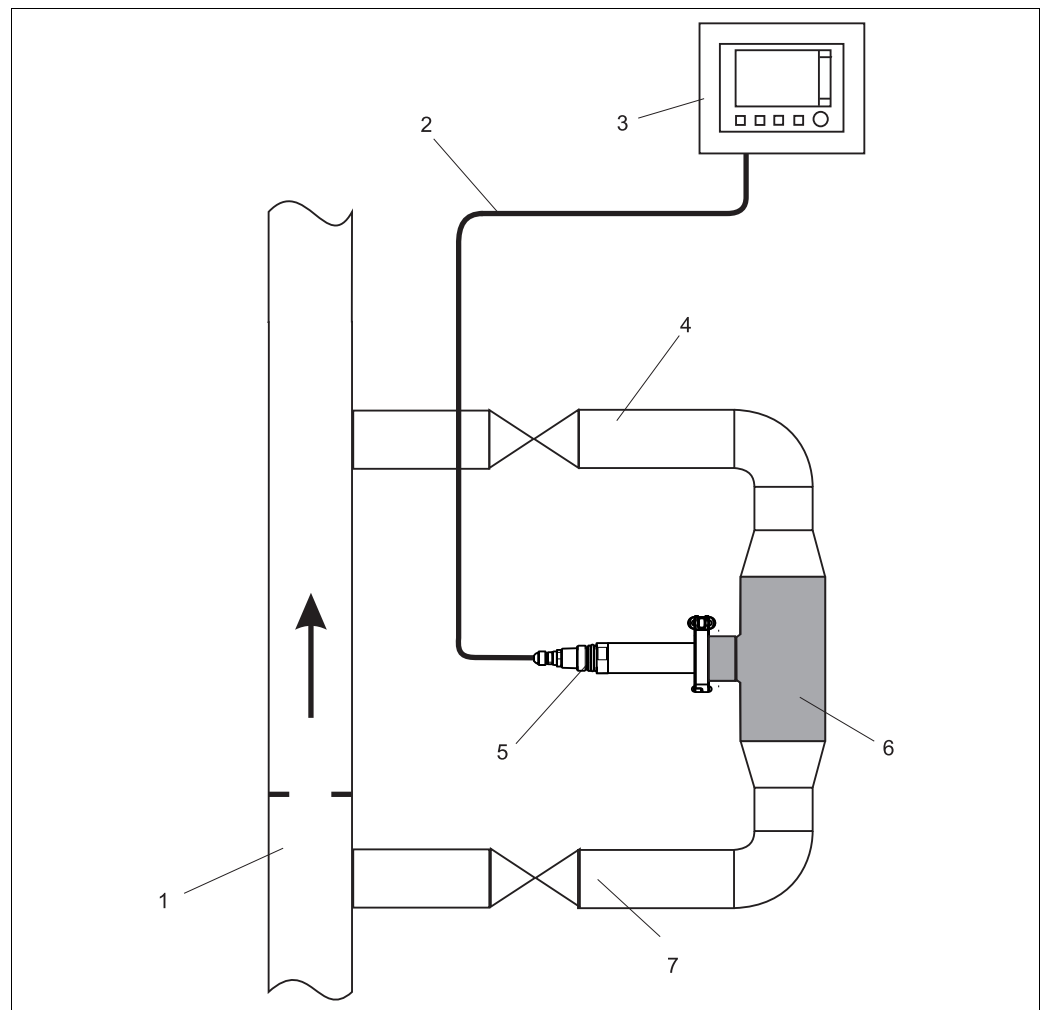

Fig. 5: Measuring system (example)

- 1 Process pipe
- 2 Measuring cable
- 3 Liquiline CM442 transmitter
- 4 Return line with shutoff valve
- 5 CUS52D sensor
- 6 CUA262 flow assembly
- 7 Supply line with shutoff valve

3.4 Sensor installation

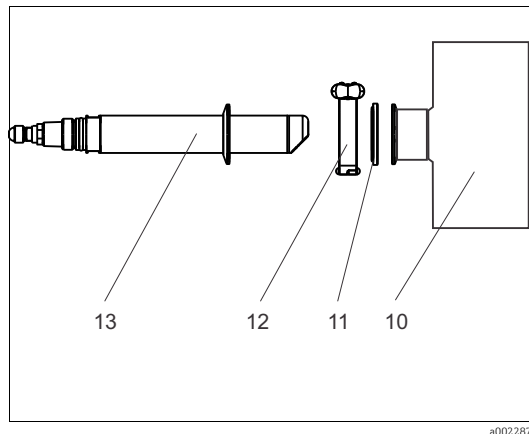

Fig. 6: Sensor installation

10 CUA262 flow assembly
11 Clamp seal
12 Locking clamp
13 CUS52D turbidity sensor

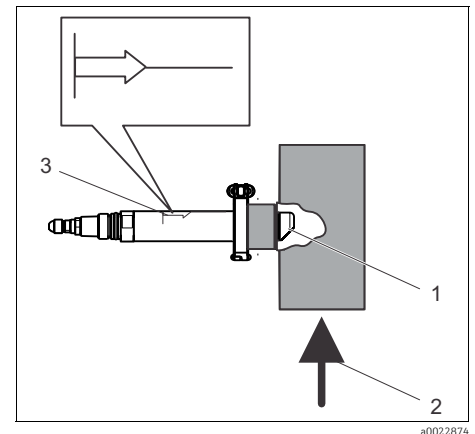



Fig. 7: Sensor orientation

1 Optical windows
2 Flow direction
3 Installation marking

Install the sensor so that the optical windows of the sensor (→ , item 1) are aligned against the flow direction (item 2). The installation marking (item 3) helps you ensure the correct sensor orientation.

3.5 Post-installation check

- ▶ After installation, check all the connections to ensure they are secure and leak-tight.
- ▶ Is the orientation correct?
- ▶ Make sure that the hoses can only be removed by force.
- ▶ Check all hoses for damage.

4 Commissioning

Prior to initial commissioning, make sure that:

- All the seals are seated correctly (on the assembly and the process connection)
- The sensor is correctly installed and connected

⚠ WARNING

Medium incorrectly connected to the assembly

Danger of medium leaking

- ▶ Before applying pressure to an assembly, make sure the medium is connected correctly!
Otherwise do not introduce the assembly into the process!

5 Maintenance

You must perform maintenance tasks at regular intervals.

We recommend setting the maintenance times in advance in an operations journal or calendar.

The maintenance cycle primarily depends on the following:

- The facility
- The installation conditions
- The medium being measured

⚠ CAUTION

Risk of injury if medium escapes

- ▶ Prior to performing any maintenance task, make sure that the process pipe is unpressurized, empty and rinsed.

5.1 Cleaning the assembly

- Use suitable cleaning solutions (see "Cleaning agents" section) to remove light dirt and fouling.
- Heavy dirt can be removed with a soft brush and a suitable cleaning agent.
- To remove stubborn dirt, soak the parts in a cleaning solution. Then clean the parts with a brush.

i Six months is a typical cleaning interval for drinking water, for example.

5.2 Cleaning the sensor

Cleaning with the ultrasonic cleaning system

If the (optional) CYR52 ultrasonic cleaning system is installed, you can clean the sensor surfaces during operation.

Enter the following parameters to prevent the ultrasonic transducer from overheating:

Cleaning time: max. 5 seconds
 Cleaning interval: min. 5 minutes

Cleaning without the ultrasonic cleaning system

If the assembly is not fitted with an ultrasonic cleaning system, you must remove the sensor in order to clean it.

Type of fouling	Cleaning measure
Lime deposits	Immerse the sensor in 1%-5 % hydrochloric acid (for a few minutes).
Dirt particles on the optical windows	Use the cleaning cloth to clean the optical windows.

i You must rinse the sensor thoroughly with water after cleaning it.

5.3 Cleaning agent

The choice of cleaning agent depends on the degree and type of fouling. The most common types of dirt and fouling and the suitable cleaning agents are listed in the following table.

Type of fouling	Cleaning agent
Greases and oils	Agents containing surfactants (alkaline agents) or water-soluble organic solvents (halogen-free, e.g. ethanol)
Limescale deposits, metal hydroxide buildup, lyophobic biological buildup	Approx. 3% hydrochloric acid
Sulfide deposits	Mixture of 3% hydrochloric acid and thiocarbamide (commercially available)
Protein buildup	Mixture of 3% hydrochloric acid and pepsin (commercially available)
Fibers, suspended substances	Pressurized water, possibly surface-active agent
Light biological buildup	Pressurized water

⚠ CAUTION

Solvents can pose a health hazard

- ▶ Never use acetone or any organic solvents containing halogens. Such solvents can damage plastic parts and some are suspected of causing cancer (e.g. chloroform).

5.4 Checking and replacing the seal

Check the seal at regular intervals and replace the seal where necessary.

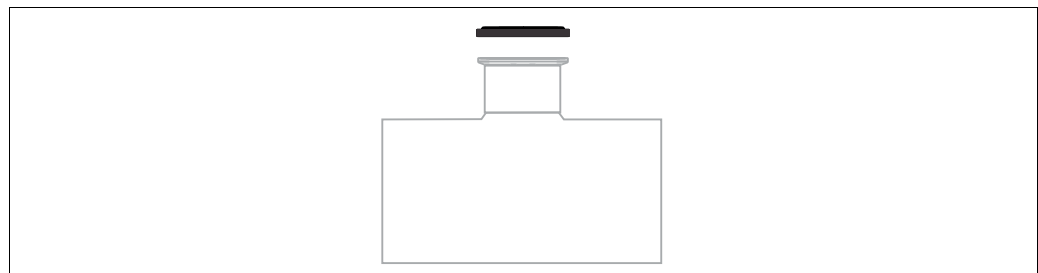

Fig. 8: Clamp seal

The seal is available as a spare parts kit (see the "Spare parts kits" section).

6 Repair

6.1 Spare parts kits

Description	Order number
Clamp seal, DN 50, FDA, 2 pcs	71241882

Detailed information on the spare parts kits is available in the "Spare Part Finding Tool", which can be accessed on the Web at:
www.products.endress.com/spareparts_consumables

6.2 Return

The product must be returned if repairs or a factory calibration are required, or if the wrong product has been ordered or delivered. According to legal regulations Endress+Hauser, as an ISO-certified company, is required to follow certain procedures when handling returned products that are in contact with the medium.

To ensure swift, safe and professional device returns:
Visit our website to obtain information about the return procedure and basic conditions:
www.services.endress.com/return-material

6.3 Disposal

Comply with local regulations when disposing of the product.

7 Accessories

7.1 Connection accessories

Description	Order number
Dummy cover for clamp connection; 1 pc	71242180

8 Technical data

8.1 Environment

Ambient temperature range 0 to 55 °C (32 to 131 °F)

Storage temperature 0 to 60 °C (32 to 140 °F) in the original packaging

8.2 Process

Process temperature 0 to 85 °C (32 to 185 °F)

Process pressure 0 to 6 bar (0 to 87 psi)

8.3 Mechanical construction

Dimensions See "Installation conditions"

Weight 1.11 kg (2.45 lbs)

Materials	Assembly housing:	Stainless steel 1.4404 (AISI 316 L)
	Seals:	EPDM
	Dummy cover:	Stainless steel 1.4404 (AISI 316 L)

Index

A

Accessories	16
Ambient temperature range	17

C

Cleaning agent	14
Commissioning	12
Connection accessories	16

D

Declaration of Conformity	6
Designated use	4
Dimensions	7
Disposal	15

E

Electromagnetic compatibility	4
-------------------------------------	---

I

Incoming acceptance	6
Installation	7
Sensor	11
Installation conditions	7
Installation instructions	10

M

Maintenance	13
Materials	17
Measuring system	10

N

Nameplate	6
-----------------	---

O

Occupational safety	4
Operational safety	4

P

Post-installation check	11
Process pressure	17
Process temperature	17
Product identification	6
Product safety	5

R

Requirements for personnel	4
Return	15

S

Safety instructions	4
Scope of delivery	6
Sensor installation	11
Spare parts kits	15
Storage temperature	17

T

Technical data	17
----------------------	----

U

Use	4
-----------	---

W

Weight	17
--------------	----



71244248

www.addresses.endress.com
