



Level



Pressure



Flow



Temperature



Liquid
Analysis



Registration



Systems
Components



Services



Solutions

Operating Instructions

Flowfit W COA250

Flow assembly for oxygen sensors

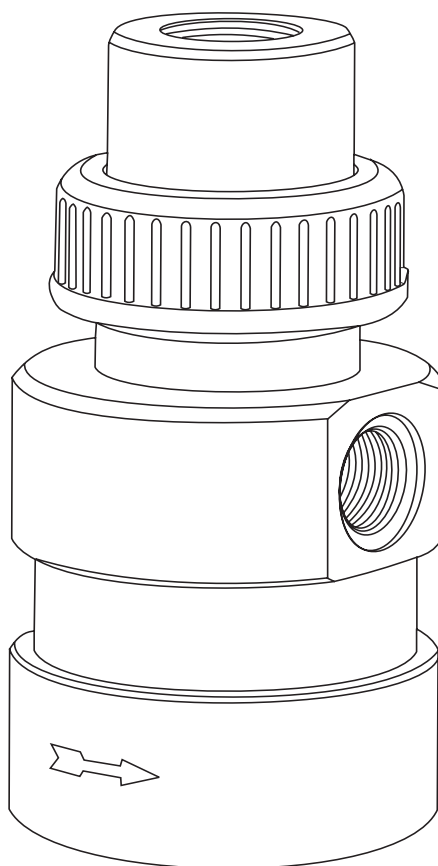

Brief overview

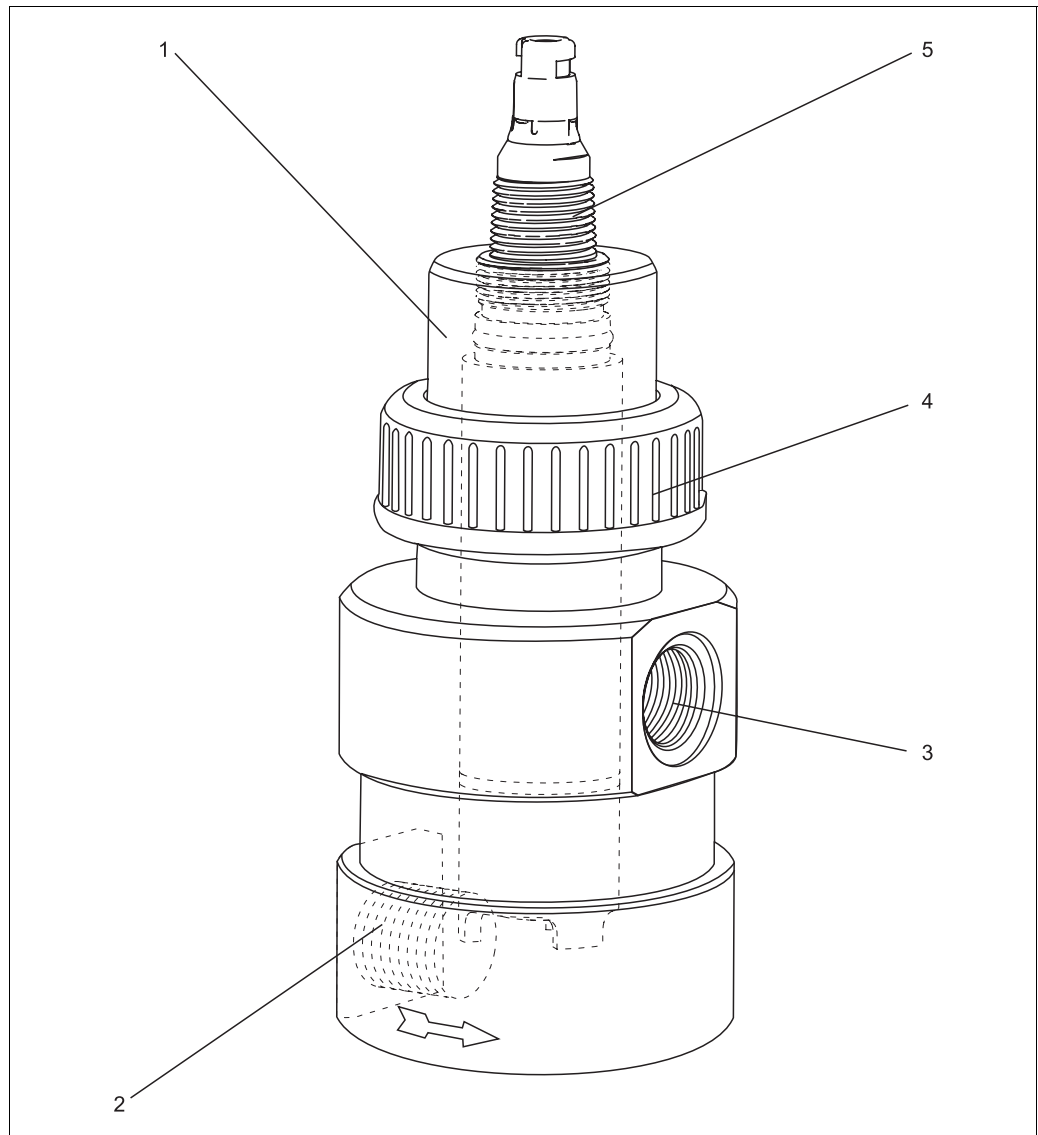

Fig. 1: COA250 with Sensor

- 1 Sensor sleeve
- 2 Inlet (G $\frac{3}{4}$ thread)
- 3 Outlet (G $\frac{3}{4}$ thread)
- 4 Union nut D50
- 5 Oxygen sensor (accessories, not in scope of delivery)

Table of contents

1	Safety instructions	4
1.1	Designated use	4
1.2	Installation, commissioning and operation	4
1.3	Operational safety	4
1.4	Return	5
1.5	Notes on safety icons and symbols	5
2	Identification	6
2.1	Nameplate	6
2.2	Product structure	6
2.3	Scope of delivery	6
3	Installation	7
3.1	Incoming acceptance, transport, storage	7
3.2	Installation conditions	7
3.3	Installation instructions	9
3.4	Post-installation check	11
4	Commissioning	12
5	Maintenance	12
5.1	Cleaning the assembly	12
5.2	Cleaning the sensor	12
5.3	Cleaning agents	13
6	Accessories	14
6.1	Accessories kits	14
6.2	Sensors	14
6.3	Cleaning systems	14
7	Trouble-shooting	15
7.1	Replacing damaged parts	15
7.2	Spare part kits	15
7.3	Return	16
7.4	Disposal	16
8	Technical data	17
8.1	Environment	17
8.2	Process	17
8.3	Mechanical construction	17
	Index	18

1 Safety instructions

1.1 Designated use

The flow assembly has been designed for the installation of oxygen sensors with Ø 40 mm (1.57 inch) in pipes and hoses. You can install the following sensors:

- COA250-A:
 - COS41
 - COS51D
 - COS3 / 3HD
 - COS4 / 4HD
- COA250-B:
 - COS31
 - COS61

Its mechanical design permits its use in pressurised systems (see "Technical data").

Any other use than the one described here compromises the safety of persons and the entire measuring system and is, therefore, not permitted.

The manufacturer is not liable for damage caused by improper or non-designated use.

1.2 Installation, commissioning and operation

Please note the following items:

- Installation, commissioning, operation and maintenance of the measuring system must only be carried out by trained technical personnel.
The technical personnel must be authorized for the specified activities by the system operator.
- Electrical connection must only be carried out by a certified electrician.
- Technical personnel must have read and understood these Operating Instructions and must adhere to them.
- Before commissioning the entire measuring point, check all the connections for correctness. Ensure that electrical cables and hose connections are not damaged.
- Do not operate damaged products and secure them against unintentional commissioning. Mark the damaged product as being defective.
- Measuring point faults may only be rectified by authorized and specially trained personnel.
- If faults can not be rectified, the products must be taken out of service and secured against unintentional commissioning.
- Repairs not described in these Operating Instructions may only be carried out at the manufacturer's or by the service organization.

1.3 Operational safety

The assembly has been designed and tested according to the state of the art and left the factory in perfect functioning order.

Relevant regulations and European standards have been met.

As the user, you are responsible for complying with the following safety conditions:

- Installation instructions
- Local prevailing standards and regulations.

1.4 Return

If the assembly has to be repaired, please return it *cleaned* to the sales center responsible. Please use the original packaging, if possible.

Please enclose the completed "Declaration of contamination" (copy the second last page of these Operating Instructions) with the packaging and the transportation documents.
No repair without completed "Declaration of contamination"!

1.5 Notes on safety icons and symbols



Warning!

This symbol alerts you to hazards. They can cause serious damage to the instrument or to persons if ignored.



Caution!

This symbol alerts you to possible faults which could arise from incorrect operation. They could cause damage to the instrument if ignored.



Note!

This symbol indicates important items of information.

2 Identification

2.1 Nameplate

You can identify the assembly version by the order code on the nameplate. Please compare this code with your order.

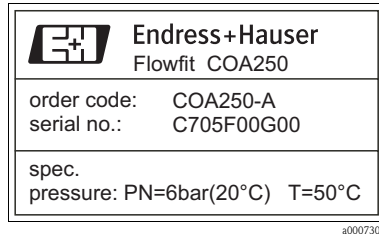

Fig. 2: Example of a nameplate

You can find possible assembly versions and the resulting order codes in the product structure.

2.2 Product structure

Version	
A	Short sensor sleeve for COS41 / 51D / 3 / 3HD / 3S / 4 / 4HD
B	Long sensor sleeve for COS31 / 61
COA250-	complete order code

2.3 Scope of delivery

The scope of delivery comprises:

- Flowfit assembly (ordered version)
- Operating Instructions (English)

If you have any questions, please contact your supplier or your sales center responsible.

3 Installation

3.1 Incoming acceptance, transport, storage

- Make sure the packaging is undamaged!
Inform the supplier about damage to the packaging. Keep the damaged packaging until the matter has been settled.
- Make sure the contents are undamaged!
Inform the supplier about damage to the delivery contents. Keep the damaged products until the matter has been settled.
- Check that the scope of delivery is complete and agrees with your order and the shipping documents.
- The packaging material used to store or to transport the product must provide shock protection and humidity protection. The original packaging offers the best protection. Also, keep to the approved ambient conditions (see "Technical data").
- If you have any questions, please contact your supplier or your sales center responsible.

3.2 Installation conditions

3.2.1 Dimensions

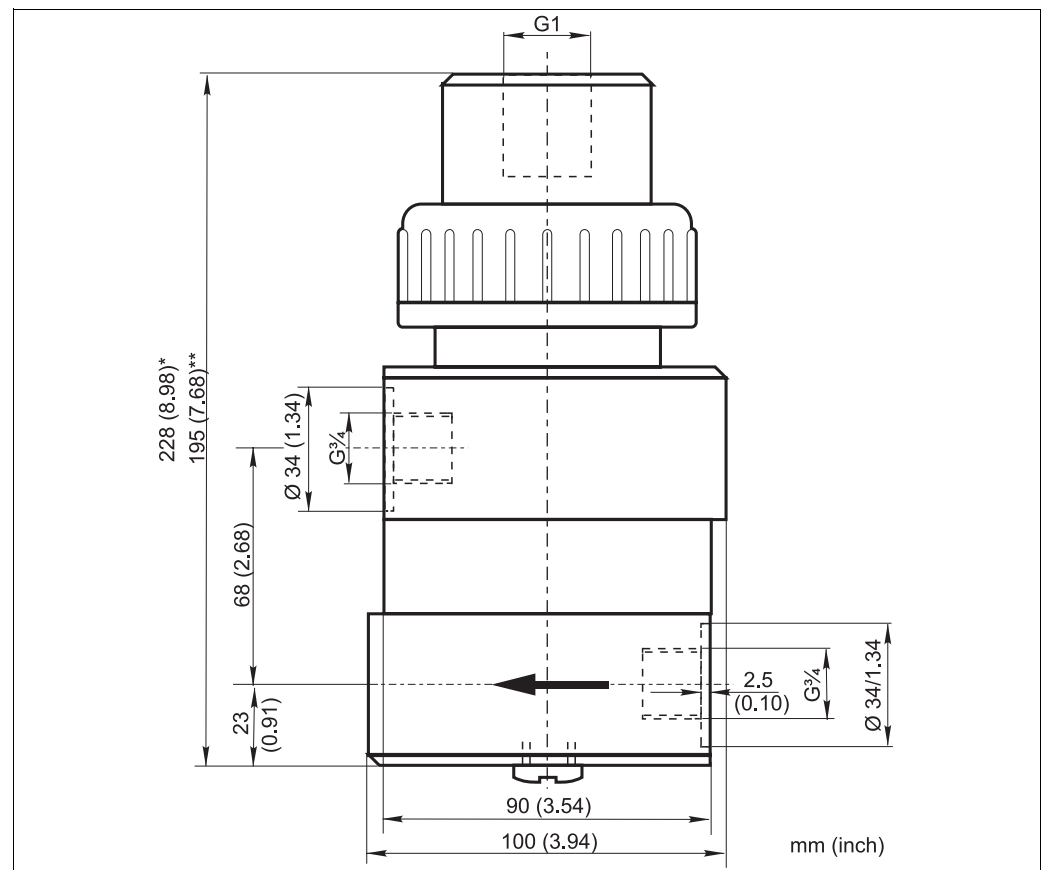

Fig. 3: Dimensions

* with long sensor sleeve (COA250-B)

** with short sensor sleeve (COA250-A)

3.2.2 Notes on installation

The flow assembly is suitable for installation in pipes and hoses. For the installation you have to provide the following:

Parts description	used at ...
two shut-off valves	bypass version
one shut-off valve	version with open outlet
aperture in the main conduit	bypass version
particle filter	if the process water contains large dirt particles
pressure-relief valve	if the process water pressure is above the maximum value (see chapter " technical data")
pipe clamp COY250 (see chapter "accessories") for plate and wall installation	hose connection
commercial fittings with a male G $\frac{3}{4}$ thread	all versions
pipe or hose connection to the flow assembly	all versions

3.3 Installation instructions

3.3.1 Measuring system

A complete measuring system comprises:

- Flowfit COA250
- Oxygen sensor, e.g. COS31, COS41, COS61 or COS51D
- Measuring cable, e.g. CYK10
- Transmitter, e.g. Liquiline M CM42

Optional:

- Junction box for cable extension, e.g. RM junction box

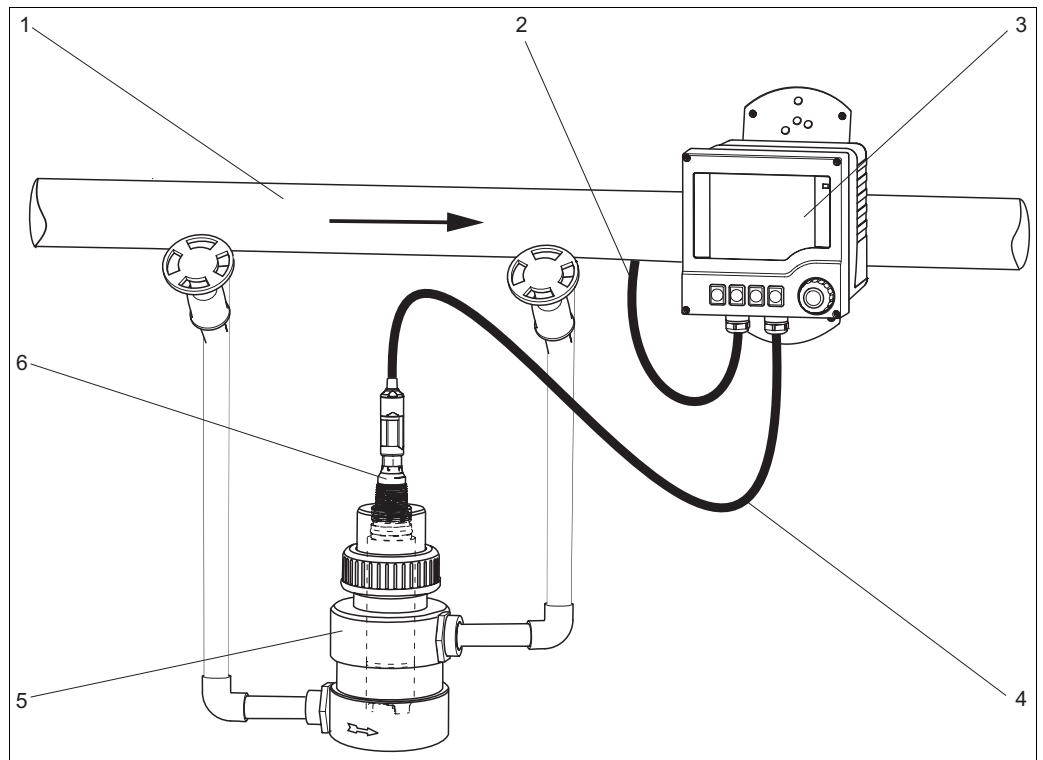



Fig. 4: Measuring system

- 1 Process line with bypass and valves
- 2 Supply line of the transmitter
- 3 Transmitter Liquiline M CM42
- 4 Measuring cable CYK10
- 5 Flowfit COA250
- 6 Oxygen sensor COS51D

3.3.2 Installing the assembly into the process

To get a flow through the bypass, pressure p_1 has to be higher than pressure p_2 . Therefore, you have to install an aperture in the main conduit (→  5).

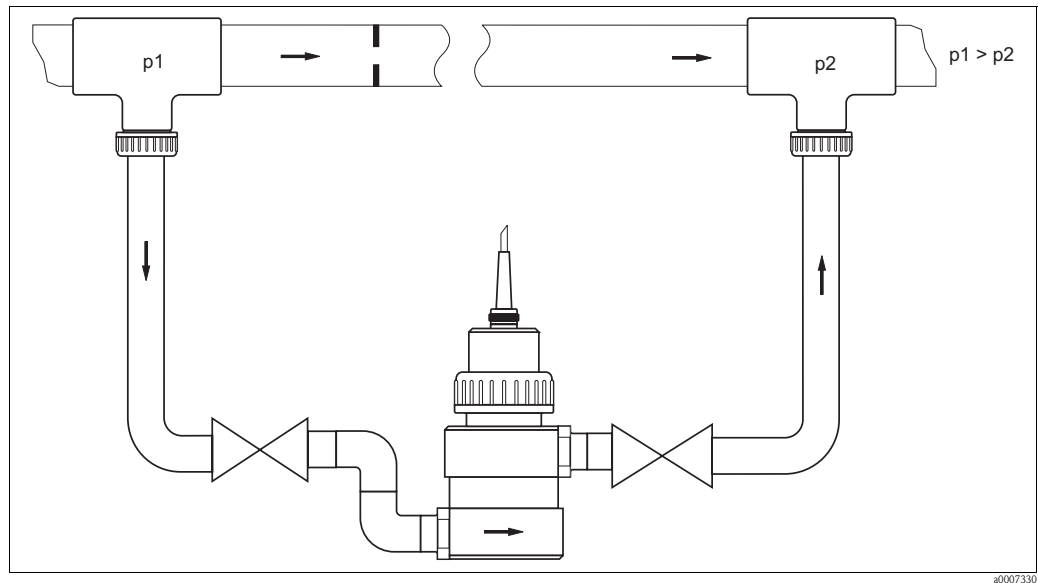

Fig. 5: Installation example with bypass and aperture in the main conduit

In case of an open outlet installation, no pressure increasing procedure is needed (→  6).

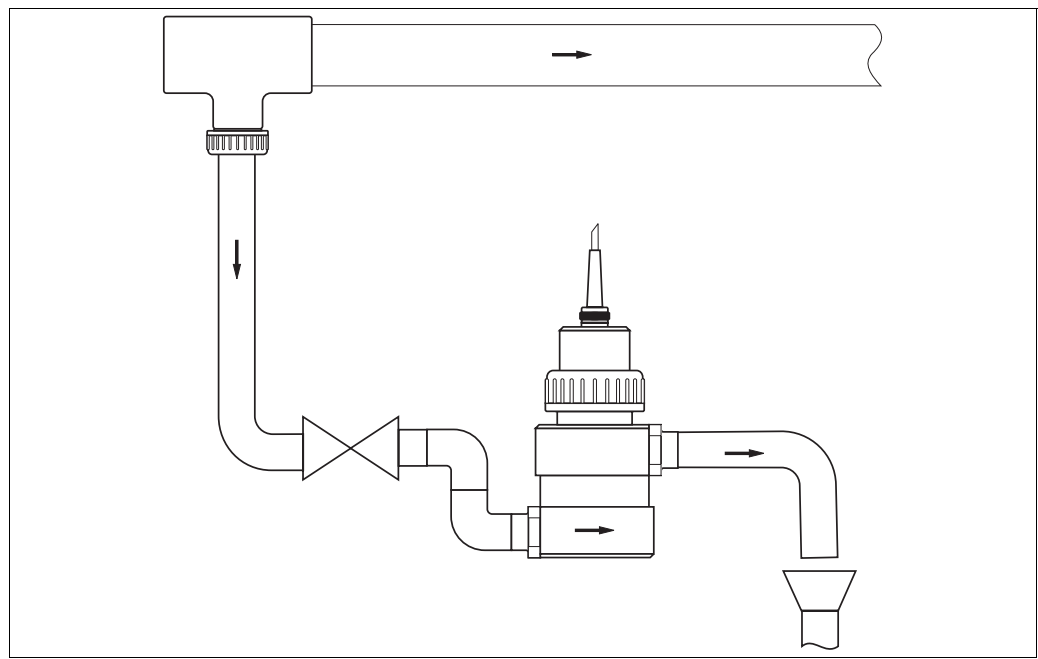

Fig. 6: Installation example with open outlet



Note!

- The flow assembly must be installed upright.
- Connect the process water with commercial fittings (male $G\frac{3}{4}$ thread). You can use the normal sealing (e.g. teflon tape) or an O-ring (ID 26.57 / W 3.53 / EPDM).
- Installation in the by-pass is preferable to installation in the process pipe as the by-pass pipe can be blocked off without process interruption (you have to install shut-off valves upstream and downstream from the flow assembly). This permits maintenance of the sensors without interrupting the process.

- Install a particle filter upstream if the process water contains large dirt particles.
- For the version with an open outlet, you have to install a shut-off valve upstream.



Caution!

- The medium pressure must not exceed the maximum permissible pressure of the flow assembly or of the sensors.
- If the medium pressure exceeds the maximum permissible pressure, you have to install a pressure-relief valve. The permissible pressure depends on the medium temperature (see "Technical Data").

3.3.3 Sensor installation

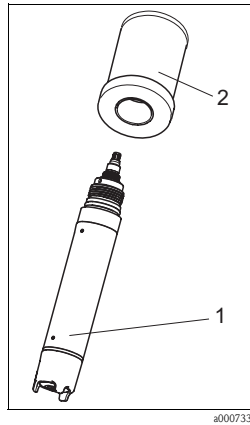

Fig. 7: Sensor installation

- 1 Sensor
2 Sensor sleeve

1. Unscrew the union nut and remove the blank cover.
2. Inspect the O-ring at the sensor head and the O-ring at the top of the assembly. Both O-rings have to be clean, undamaged and slightly lubricated.
3. Remove the protection basket from the sensor.
4. Screw the sensor into the sensor sleeve (→ 7).
5. Insert the sensor with the sensor sleeve into the assembly.
6. Tighten the sensor sleeve with the union nut.
7. Keep the blank cover for future operation of the flow assembly without an oxygen sensor.

3.4 Post-installation check

- After installation, check that all connections are firmly in position and leak-tight.
- Ensure that the hose of the spray nozzle (optionally) cannot be removed without force.
- Check all hoses for damage.

4 Commissioning

Before the first commissioning, make sure of the following items:

- all seals are correctly seated (on the assembly and process connection)
- the sensor is correctly installed and connected



Warning!

Danger of squirting medium.

Before applying the process pressure to the assembly, make sure the connections are correctly fitted.

5 Maintenance



Warning!

Risk of injury!

Before starting maintenance work on the assembly, make sure that the process line is depressurised, empty and rinsed.

5.1 Cleaning the assembly

To ensure a reliable measurement, the assembly and the sensor must be cleaned at regular intervals. The frequency and intensity of the cleaning operation depend on the process medium.

All parts in contact with the medium, e.g. the sensor and the sensor holder, must be cleaned at regular intervals. Remove the sensor¹⁾.

- Remove light dirt using suitable cleaning agents (see chapter "Cleaning agents").
- Remove severe fouling with a soft brush and a suitable cleaning agent.
- Remove persistent fouling by soaking in a liquid cleaner and if necessary by cleaning with a soft brush.

5.2 Cleaning the sensor

You have to clean the sensor:

- before every calibration
- regularly during operation
- before being returned for repair

If the spray nozzle CUR 3 is installed (see chapter "accessories"), you can clean the sensor membrane during operation. For the CUR 3, we recommend a pressure of 1 – 2 bar (15 –29 psi) above the process pressure.

If there is no spray nozzle installed, you have to dismount the sensor and to clean it manually.



Note!

- Do not use any abrasive cleaning agents. This can lead to irreparable damage of the sensor.
- After cleaning the sensor, rinse the rinse chamber of the assembly with copious amounts of water. Otherwise, remaining residues of cleaning agent can corrupt measurement.
- If required, re-calibrate after cleaning.

1) in reverse sequence of operations to the installation procedure

5.3 Cleaning agents

The selection of the cleaning agent is dependent on the degree and type of contamination. The most common contaminations and the suitable cleaning agents are listed in the following table.

Type of contamination	Cleaning agent
Greases and oils	Substances containing tensides (alkaline) or water-soluble organic solvents (e.g. Ethanol)
Calciferous deposits, metal hydroxide deposits, lyophobic biological deposits	approx. 3% hydrochloric acid
Sulphide deposits	Mixture of 3% hydrochloric acid and thiocarbamide (commercially available)
Protein deposits	Mixture of 3% hydrochloric acid and pepsin (commercially available)
Fibres, suspended substances	Water under pressure, poss. with surface-active agents
Light biological deposits	Water under pressure



Caution!

Do not use organic solvents containing halogen or acetone. These solvents could destroy plastic components on the assembly or the sensor and it is also partly suspected that they cause cancer (e.g. Chloroform).

6 Accessories



Note!

In the following sections, you find the accessories available at the time of issue of this documentation.

For information on accessories that are not listed here, please contact your responsible service.

6.1 Accessories kits

Long sensor sleeve

- For later installation of sensor COS31 / 61 into COA250-A assembly
- order no. 51507172

Pipe clamp COY250

- For panel or wall mounting
- order no. 50065132

6.2 Sensors

Oxymax W COS31

- Oxygen sensor for drinking water and wastewater measurements, potentiostatic amperometric principle
- Material: stainless steel 1.4571 (AISI 316 Ti)
- Ordering acc. to product structure, see Technical Information (TI285C/07/en)

Oxymax W COS41

- Oxygen sensor for drinking water and wastewater measurements, amperometric principle
- Material: POM
- Ordering acc. to product structure, see Technical Information (TI284C/07/en)

Oxymax W COS51D

- Amperometric sensor for dissolved oxygen, with Memosens technology
- Ordering acc. to product structure, see Technical Information (TI413C/07/en)

Oxymax W COS61

- Optical oxygen sensor for drinking water and wastewater measurements, fluorescence quenching principle
- Material: stainless steel 1.4571 (AISI 316 Ti)
- Ordering acc. to product structure, see Technical Information (TI387C/07/en)

6.3 Cleaning systems

Chemoclean CUR3

- Spray head for flow assemblies CUA250 and COA250
- order no. CUR3-1

Chemoclean

- Injector CYR10 and programme sequencer CYR20
- Ordering acc. to product structure, see Technical Information (TI046C/07/en)

7 Trouble-shooting

7.1 Replacing damaged parts



Warning!

Damage to the assembly which affects the pressure safety must **only** be repaired by authorized technical personnel.

After every repair and maintenance activity, suitable measures must be taken to test whether the assembly shows any signs of leaking. The assembly must then correspond to the specifications stated in the technical data.

Replace all other damaged components immediately. To order accessories and spare parts, please use the "Accessories" and "Spare parts" chapters or contact your sales center responsible.

7.2 Spare part kits

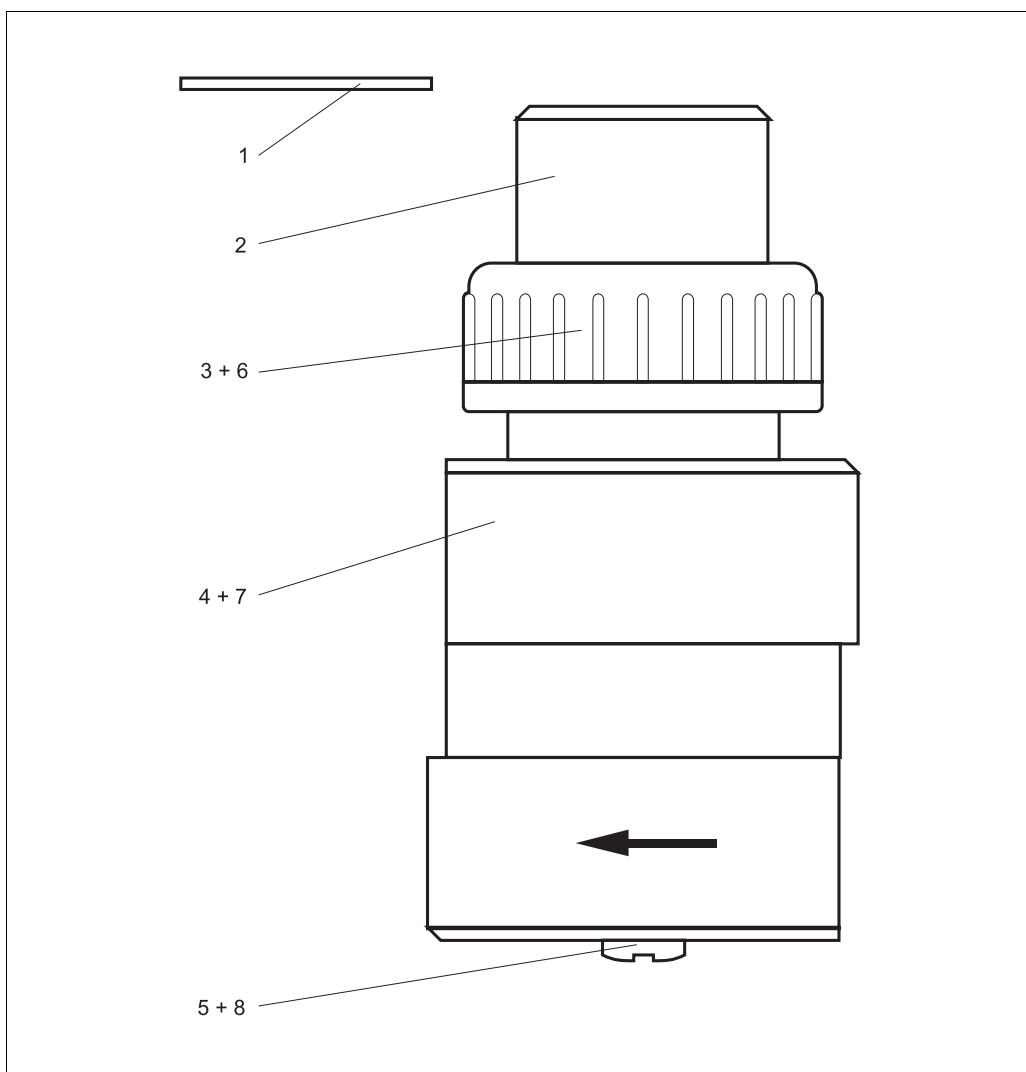

Fig. 8: Spare parts



Note!

Please, refer to the following table for the spare part kits ordering numbers acc. to the positions in Fig. 8.

Position	Description and kit content	Spare part kit order no.
1	blank cover	50060703
2	short sensor sleeve (for COA 250-A)	50061685
2	long sensor sleeve (for COA 250-B)	51507172
3	union nut D50	50012700
4	housing	50061684
5	locking screw ¼"	50060811
6	O-ring ID 53.57 (2.11") W 3.53 (0.14") EPDM	50013429
7	screw-in part	50060705
8	O-ring ID12.42 (0.49") W1.78 (0.07") EPDM	50011564

7.3 Return

If the assembly has to be repaired, please return it *cleaned* to the sales center responsible. Please use the original packaging, if possible.

Please enclose the completed "Declaration of contamination" (copy the second last page of these Operating Instructions) with the packaging and the transportation documents.
No repair without completed "Declaration of contamination"!

7.4 Disposal

Please dispose of the device in accordance with the local regulations.

8 Technical data

8.1 Environment

Ambient temperature range 0 ... 50 °C (32 ... 120 °F)

Storage temperature 0 ... 50 °C (32 ... 120 °F)

8.2 Process

Process temperature 0 to 50 °C (32 to 120 °F), non-freezing

Process pressure max. 6 bar (87 psi) at 20 °C (68 °F) and 4 bar (58 psi) at 50 °C (122 °F)

Temperature-pressure-diagram

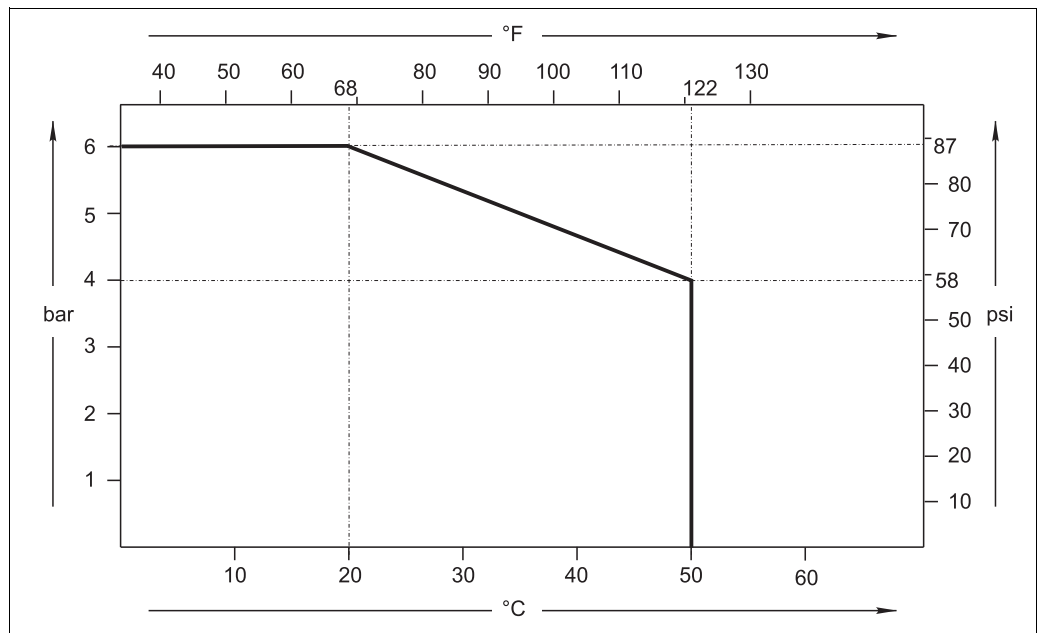

Fig. 9: Temperature-Pressure diagram

8.3 Mechanical construction

Design, dimensions see chapter "Installation"

Weight 0.5 to 0.8 kg (1.1 to 1.8 lbs), depending on process connection

Material EPDM (sealings)
PVC

Process connection G $\frac{3}{4}$ (for usual fittings)

Index

A

Accessories	14
Cleaning systems	14
Sensors	14
Assembly	
Cleaning	12

C

Checking	
Installation	11
Cleaning	
Agents	13
Assembly	12
Sensor	12
Commissioning	4

D

Designated use	4
Dimensions	7
Disposal	16

E

Environment	17
-------------------	----

I

Icons	5
Incoming acceptance	7
Installation	4, 7, 9
Sensor	11

M

Maintenance	12
Measuring system	9
Mechanical construction	17

N

Nameplate	6
-----------------	---

O

Operation	4
Operational safety	4
Ordering information	6

P

Parts	
Replacing	15
Process	17
Product structure	6

R

Replacing	
Parts	15
Return	5, 16

S

Safety icons	5
Scope of delivery	6

Sensor

Cleaning	12
Installation	11
Spare parts	15
Storage	7
Symbols	5

T

Transport	7
-----------------	---

U

Use	4
-----------	---

Declaration of Hazardous Material and De-Contamination *Erklärung zur Kontamination und Reinigung*

RA No.

Please reference the Return Authorization Number (RA#), obtained from Endress+Hauser, on all paperwork and mark the RA# clearly on the outside of the box. If this procedure is not followed, it may result in the refusal of the package at our facility.
Bitte geben Sie die von E+H mitgeteilte Rücklieferungsnummer (RA#) auf allen Lieferpapieren an und vermerken Sie diese auch außen auf der Verpackung. Nichtbeachtung dieser Anweisung führt zur Ablehnung ihrer Lieferung.

Because of legal regulations and for the safety of our employees and operating equipment, we need the "Declaration of Hazardous Material and De-Contamination", with your signature, before your order can be handled. Please make absolutely sure to attach it to the outside of the packaging.

Aufgrund der gesetzlichen Vorschriften und zum Schutz unserer Mitarbeiter und Betriebseinrichtungen, benötigen wir die unterschriebene "Erklärung zur Kontamination und Reinigung", bevor Ihr Auftrag bearbeitet werden kann. Bringen Sie diese unbedingt außen an der Verpackung an.

Type of instrument / sensor

Geräte-/Sensortyp _____

Serial number

Seriennummer _____

Used as SIL device in a Safety Instrumented System / Einsatz als SIL Gerät in Schutzeinrichtungen

Process data / Prozessdaten

Temperature / Temperatur _____ [°F] _____ [°C]

Pressure / Druck _____ [psi] _____ [Pa]

Conductivity / Leitfähigkeit _____ [µS/cm]

Viscosity / Viskosität _____ [cp] _____ [mm²/s]

Medium and warnings

Warnhinweise zum Medium



	Medium /concentration <i>Medium /Konzentration</i>	Identification CAS No.	flammable <i>entzündlich</i>	toxic <i>giftig</i>	corrosive <i>ätzend</i>	harmful/ irritant <i>gesundheitsschädlich/ reizend</i>	other * <i>sonstiges*</i>	harmless <i>unbedenklich</i>
Process medium <i>Medium im Prozess</i>								
Medium for process cleaning <i>Medium zur Prozessreinigung</i>								
Returned part cleaned with <i>Medium zur Endreinigung</i>								

* explosive; oxidising; dangerous for the environment; biological risk; radioactive

* *explosiv; brandfördernd; umweltgefährlich; biogefährlich; radioaktiv*

Please tick should one of the above be applicable, include safety data sheet and, if necessary, special handling instructions.

Zutreffendes ankreuzen; trifft einer der Warnhinweise zu, Sicherheitsdatenblatt und ggf. spezielle Handhabungsvorschriften beilegen.

Description of failure / Fehlerbeschreibung _____

Company data / Angaben zum Absender

Company / Firma _____	Phone number of contact person / Telefon-Nr. Ansprechpartner: _____
Address / Adresse _____	Fax / E-Mail _____
_____	Your order No. / Ihre Auftragsnr. _____

"We hereby certify that this declaration is filled out truthfully and completely to the best of our knowledge. We further certify that the returned parts have been carefully cleaned. To the best of our knowledge they are free of any residues in dangerous quantities."

"Wir bestätigen, die vorliegende Erklärung nach unserem besten Wissen wahrheitsgetreu und vollständig ausgefüllt zu haben. Wir bestätigen weiter, dass die zurückgesandten Teile sorgfältig gereinigt wurden und nach unserem besten Wissen frei von Rückständen in gefahrbringender Menge sind."

(place, date / Ort, Datum)

Name, dept./Abt. (please print / bitte Druckschrift)

Signature / Unterschrift

www.endress.com/worldwide

Endress+Hauser 
People for Process Automation

