



Füllstand



Druck



Durchfluss



Temperatur



Flüssigkeits-
analyse



Registrierung



Systeme
Komponenten



Services



Solutions

Operating Instructions

Stamoclean CAT430-*2

Micro/ultra filtration system with high power membrane pump

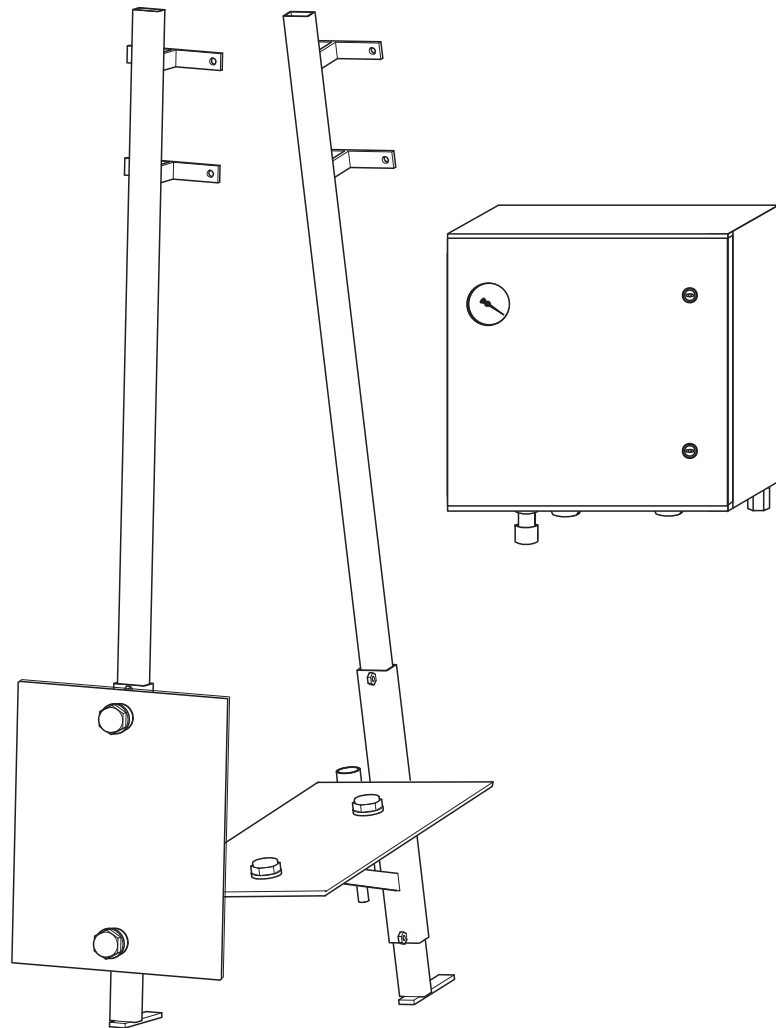

Table of contents

1	Safety instructions	4	10	Technical data	46
1.1	Designated use	4	10.1	Power supply	46
1.2	Installation, commissioning and operation	4	10.2	Performance characteristics	46
1.3	Operational safety	4	10.3	Environment	46
1.4	Return	4	10.4	Process	47
1.5	Notes on safety conventions and icons	5	10.5	Mechanical construction	47
1.6	Cross reference symbols	5			
2	Identification	6		Index	48
2.1	Nameplate	6			
2.2	Scope of delivery	7			
2.3	Certificates and approvals	7			
3	Installation	8			
3.1	Incoming acceptance, transport, storage	8			
3.2	Quick installation guide	8			
3.3	Installation instructions	9			
3.4	Post-installation check	15			
4	Wiring	16			
4.1	Electrical connection	16			
4.2	Post-connection check	19			
5	Operation	20			
5.1	Operation and commissioning	20			
5.2	Display and operating elements	20			
5.3	Local operation	21			
6	Commissioning	24			
6.1	Function check	24			
6.2	Switch-on	24			
6.3	Checking the sample transportation	26			
6.4	Checking the sampling quantity	27			
6.5	Setting the collecting volume	27			
7	Maintenance	28			
7.1	Maintenance activities	28			
7.2	Repairs	31			
8	Accessories	39			
8.1	Filter element holders	39			
8.2	Filter element accessories	40			
9	Troubleshooting instructions	41			
9.1	Troubleshooting instructions	41			
9.2	Spare parts	43			
9.3	Return	45			
9.4	Disposal	45			

1 Safety instructions

1.1 Designated use

The CAT430 micro/ultra filtration system is designated to take samples for process measuring devices in sewage treatment plants.

The system transports clear samples directly from the clarification basin to the measuring device.

Any other use than the one described here compromises the safety of persons and the entire measuring system and is, therefore, not permitted.

The manufacturer is not liable for damage caused by improper or non-designated use.

1.2 Installation, commissioning and operation

Please note the following items:

- Installation, commissioning, operation and maintenance of the measuring system must only be carried out by trained technical personnel.
The technical personnel must be authorized for the specified activities by the system operator.
- Electrical connection must only be carried out by a certified electrician.
- Technical personnel must have read and understood these Operating Instructions and must adhere to them.
- Before commissioning the entire measuring point, check all the connections for correctness. Ensure that electrical cables and hose connections are not damaged.
- Do not operate damaged products and secure them against unintentional commissioning. Mark the damaged product as being defective.
- Measuring point faults may only be rectified by authorized and specially trained personnel.
- If faults can not be rectified, the products must be taken out of service and secured against unintentional commissioning.
- Repairs not described in these Operating Instructions may only be carried out at the manufacturer's or by the service organization.

1.3 Operational safety

The product is designed to meet state-of-the-art safety requirements, has been tested and left the factory in a condition in which it is safe to operate.

Relevant regulations and European standards have been observed.

As the user, you are responsible for complying with the following safety conditions:

- Installation instructions
- Local prevailing standards and regulations.

1.4 Return

If the device requires repair, please send it *cleaned* to the sales center responsible.

Please use the original packaging, if possible.

Please enclose the completed "Declaration of contamination" (copy the second last page of these Operating Instructions) with the packaging and the transportation documents. No repair without completed "Declaration of contamination"!

1.5 Notes on safety conventions and icons

1.5.1 On the device

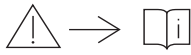

This symbol is found in various places on the device (nameplate, connection box, cable duct cover). The symbol indicates that it is essential that you read the Operating Instructions for the subject in question.

1.5.2 In these Operating Instructions



Warning!

This symbol alerts you to hazards. They can cause serious damage to the instrument or to persons if ignored.



Caution!

This symbol alerts you to possible faults which could arise from incorrect operation. They could cause damage to the instrument if ignored.



Note!

This symbol indicates important items of information.

1.6 Cross reference symbols

→  1 This symbol indicates a cross reference to a defined page (e.g. p. 1).

→  2 This symbol indicates a cross reference to a defined figure (e.g. fig. 2).

2 Identification

2.1 Nameplate

The nameplate contains the following information:

- Manufacturer data
- Order code
- Extended order code
- Serial number
- Operating conditions
- Safety icons

Compare the order code on the nameplate with your order.

2.1.1 Order code

You can check the order code of your device online at:
www.products.endress.com/cat430

1. You can choose from the following options on the product page located on the right:

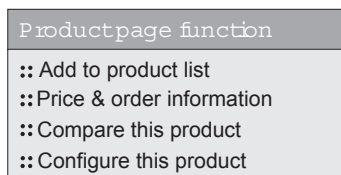

2. Click "Configure this product".
3. The Configurator opens in a separate window. You can now configure your device and receive the complete order code that applies for the device.
4. Afterwards, export the order code as a PDF or Excel file. To do so, click the appropriate button at the top of the page.

2.2 Scope of delivery

The scope of delivery comprises:

- 1 Control box, complete with
 - Filtrate line connected, length 4.5 m (14.8 ft), hose heating 24 VAC
 - 4 Plastic brackets for wall mounting
 - 2 Pipe clamps 44 - 49 mm (1.73 - 1.93 inch), set screw M8, for rail mounting
 - 1 Rubber stop with screw, for rail mounting
- Accessories bag with:
 - 1 Collecting vessel with PE hose 10/8 mm (0.31/0.39 inch), length 2.5 m (8.2 ft)
 - 1 PE hose roll 4/2 mm (0.16/0.08 inch), length 2.5 m (8.2 ft)
 - 1 PVC hose roll 4/2 mm (0.16/0.08 inch), length 2.0 m (6.7 ft)
 - 1 PTFE hose roll 3/1.5 mm (0.12/0.06 inch), length 2.5 m (8.2 ft)
(only with filtrate line length > 20 m (66 ft))
 - 1 Housing key
 - 1 Allen key 4 mm
 - 1 Allen key 4 mm with handle, 200 mm
 - 1 Dummy plug
 - 1 Pressure surge reducer
 - 1 Screw-in connector 4 - 1/8 inch
 - 1 Straight connector 4 mm (0.16 inch)
 - 1 Reducing fitting 4 mm outside/ 3 mm inside
- 1 or 2 Filter plate(s) (depending on ordered version)
- 1 or no assembly (depending on ordered version)
- 1 Filtrate line with PE filtrate hose 4/2 mm (0.16/0.08 inch), min. length 20 m (66 ft)
(depending on version)
- 1 Acceptance certificate
- 1 Operating Instructions BA380C/07/EN

2.3 Certificates and approvals

Declaration of conformity

The product meets the requirements of the harmonized European standards.

It thus complies with the legal requirements of the EC directives.

The manufacturer confirms successful testing of the product by affixing the **CE** symbol.

3 Installation

3.1 Incoming acceptance, transport, storage

- Make sure the packaging is undamaged!
- Inform the supplier about damage to the packaging. Keep the damaged packaging until the matter has been settled.
- Make sure the contents are undamaged!
- Inform the supplier about damage to the delivery contents. Keep the damaged products until the matter has been settled.
- Check that the scope of delivery is complete and agrees with your order and the shipping documents.
- The packaging material used to store or to transport the product must provide shock protection and humidity protection. The original packaging offers the best protection. Also, keep to the approved ambient conditions (see "Technical data").
- If you have any questions, please contact your supplier or your sales center responsible.

3.2 Quick installation guide

A complete measuring system comprises:

- a CAT430 filter system
- a collecting vessel
- a CA71xx analyzer

Optionally, a sensor with flow assembly can also be integrated into the measuring system (external only, cannot be installed in the control box housing).

If an assembly with low dead volume and flow resistance is used (see "Accessories"), the sensor can be installed in line with the analyzer's inlet.

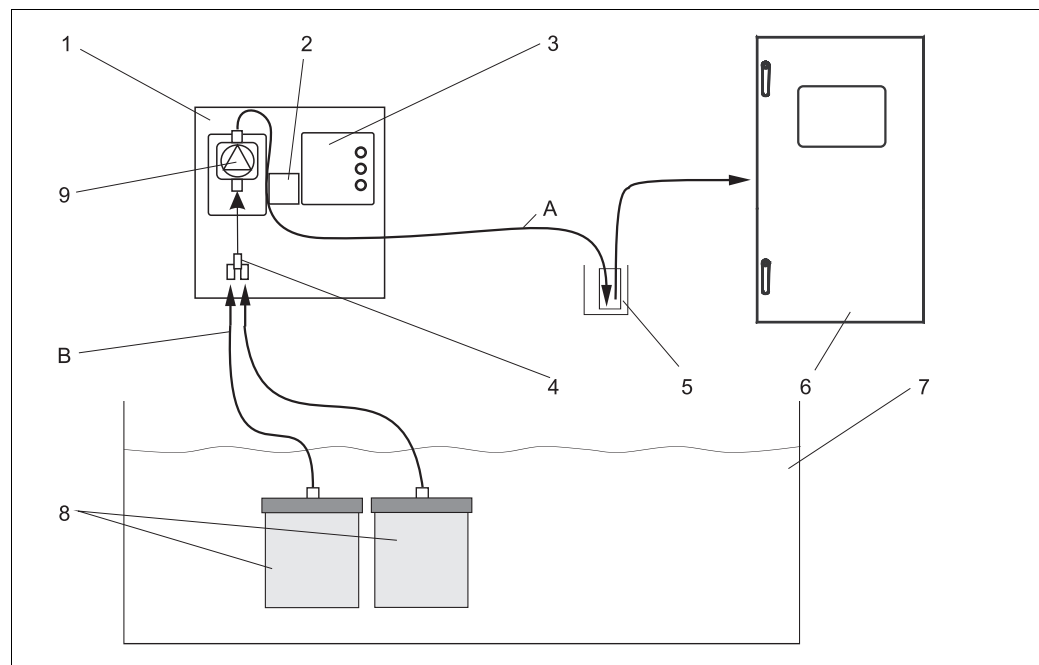

Fig. 1: Measuring system

- | | | | |
|---|---|---|------------------------|
| 1 | Control box | 6 | Analyzer |
| 2 | Timer | 7 | Activated sludge basin |
| 3 | Control unit | 8 | Membrane filter |
| 4 | Y-piece | 9 | Membrane pump |
| 5 | Collecting vessel | | |
| A | Sample line to the analyzer (discharge side of pump, PE 4/2 mm (0.16/0.08"), max. 20 m (66 ft)) | | |
| B | Filtrate line from the membrane filters (suction side of the pump, PE, 4.5 m (15 ft) standard, with hose heating) | | |

3.3 Installation instructions

To mount the individual modules, proceed as follows:

1. Mount the filter element holders.
2. Mount the guide tube, retaining slide and filtrate line.
3. Mounting the filter elements.
4. Mounting the control box.
5. Connect the sample lines to the measuring devices.



Caution!

- Before beginning installation, make sure that there are no pipes, stirrers or other equipment up to approx. 1 m (3.3 ft) below the surface of the water at the intended point of installation. This equipment can damage the filter elements.
- Check that there is sufficient space between the filter unit and the rim of the basin. This applies especially to filter units with numerous filter elements. If there is not sufficient space, a special holder must be used.
- The flow rate at the point of installation must not be over 2 m/s (6.6 ft/s).

3.3.1 Mounting the filter element holders.



Note!

Please, order filter element holders separately. See "Accessories".

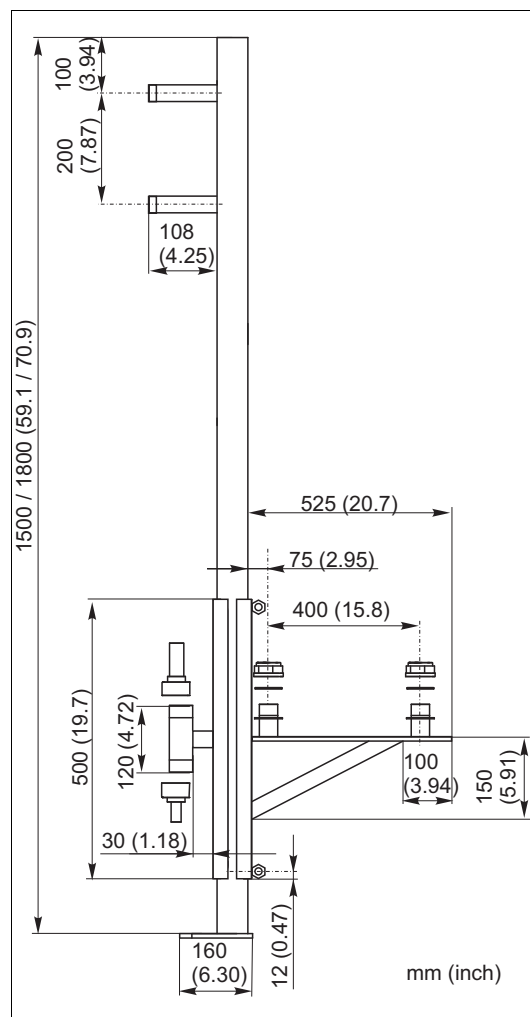

Fig. 2: Holder for open channel, side view

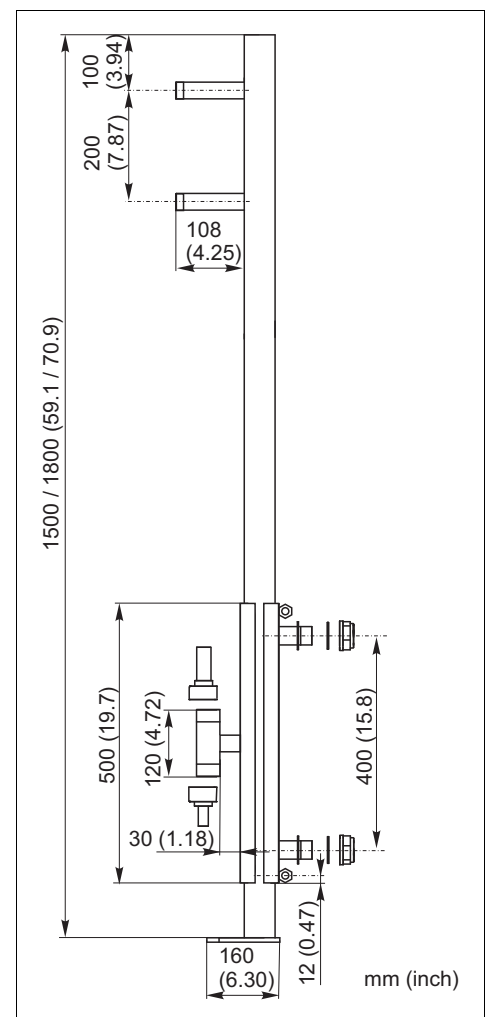

Fig. 3: Holder for basin, side view

**Note!**

You will need a hammer drill with a 12 mm (0.47 inch) drill bit.

Proceed as follows to secure the holder to the edge of the basin:

1. Drill four holes with a diameter of 12 mm (0.47 inch) into the side of the wall facing the basin. The distance from the upper end of the wall should be approx. 10 cm (3.94 inch).
2. Screw the holders in.
Make sure, the basin holder is at least 60 cm (23.6 inch) below the water level (or the open channel holder at least 35 cm (13.8 inch)).

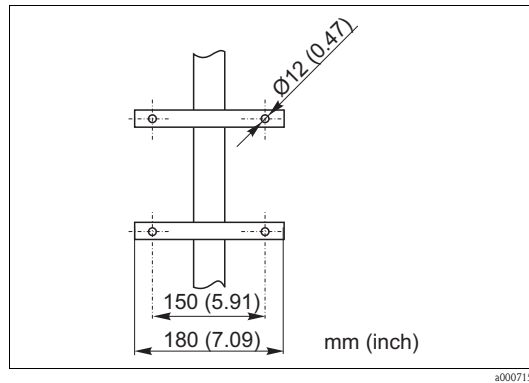

Fig. 4: Detail: wall mounting of the filter holder (accessories)

3.3.2 Mounting the retaining slide and filtrate line

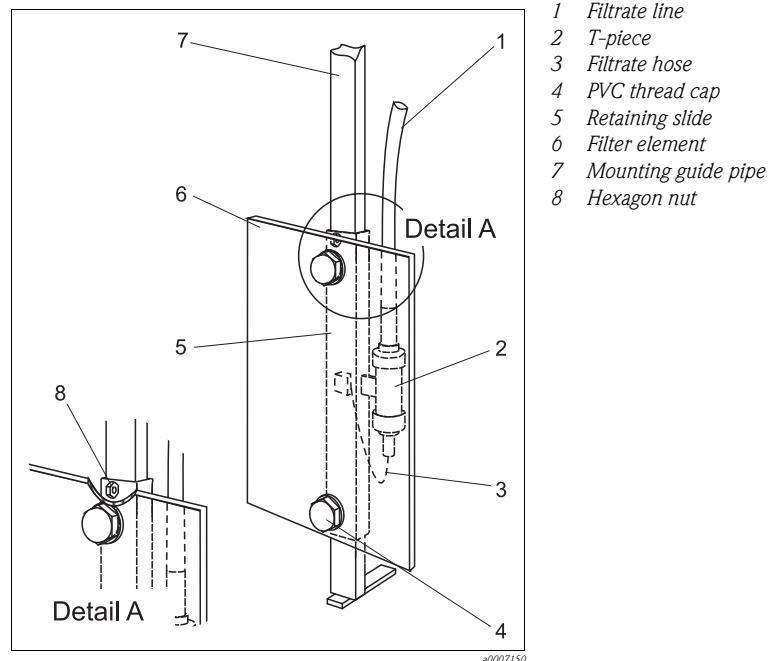



Fig. 5: Filter element with retaining slide

**Caution!**

- Secure the retaining slide, the stainless steel chain, the filtrate line and the PVC caps, in order to prevent them falling into the basin.
- Do not push the retaining slide onto the mounting guide pipe before having mounted the filter elements.

Perform the following steps outside the basin or the open channel:

1. Feed the filtrate hose (→  5, item 3) of the filtrate line (item 1) through the T-piece (item 2) at the PVC retaining slide (item 5).
2. Screw the filtrate line in tight with the PVC hose gland of the T-piece.
3. Fasten the stainless steel chain at the retaining slide by directing it through the hexagon nut (item 8).
4. Remove the PVC screw caps (item 4) and place them so that they can be reached.

3.3.3 Mounting the filter elements

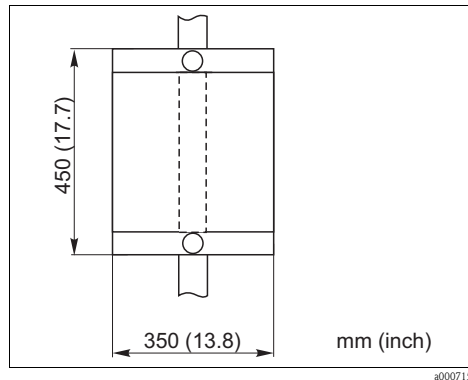

Fig. 6: Filter element

The filter elements are delivered ready for use. They are packed in a plastic bag with an additional cover of corrugated cardboard to protect them against mechanical damage.



Caution!

- The surface of the filter element membrane (bright surface) must not be touched or in any way scratched with sharp objects or fingernails. Otherwise, the membrane is irreparably damaged. Therefore, always handle the filter element at the free-standing PVC ends.
- Once it is used for the first time in the basin, always keep the membrane moist. Otherwise, it becomes brittle and breaks.



Note!

You will need an open-end wrench 14/15 a/f.

Installation:

1. Open the corrugated cardboard cover at the top by removing the tear-off strip.
2. Remove the corrugated cardboard spacer. There is a threaded elbow joint in the middle of it, which you will require in the step after the next.
3. Take out the filter plate and remove the plastic bag.
4. Screw the threaded elbow joint into the threaded hole on the reverse side of the filter element. Carefully tighten the threaded elbow joint with the open-end wrench, so that the O-ring on the threaded elbow joint seals cleanly to the PVC carrier plate. Avoid over-tightening the thread.
5. Have the PVC screw caps (→  5, item 4) ready.
6. Put the filter plate onto both threaded adapters at the retaining slide (item 5) such that the threaded elbow joint faces the retaining slide.
7. Screw the PVC cap on by hand.
8. Cut the filtrate hose (item 3) to the right length, so that it runs in the bend.

**Note!**

When using numerous filter elements, ensure that the colored identification sleeves on the filtrate hoses do not fall off and are not cut off. Used tubes should be shortened by approx. 10 mm (0.39 inch) because the lateral surface always gets scratched somewhat when pulled out. This leads to leakages.

9. Slide the filtrate hose into the threaded elbow joint coupling and press it all the way in. There is an O-ring in the coupling, so that the hose has to be pressed in until a pressure point has been overcome.
10. Push the retaining slide with the filter element (item 6) onto the mounting guide pipe.
11. Put the retaining slide with the filter element down by the chain until the limit stop. Secure the chain end at the rail.
The complete filter unit has to be below the water level.

3.3.4 Mounting the control box

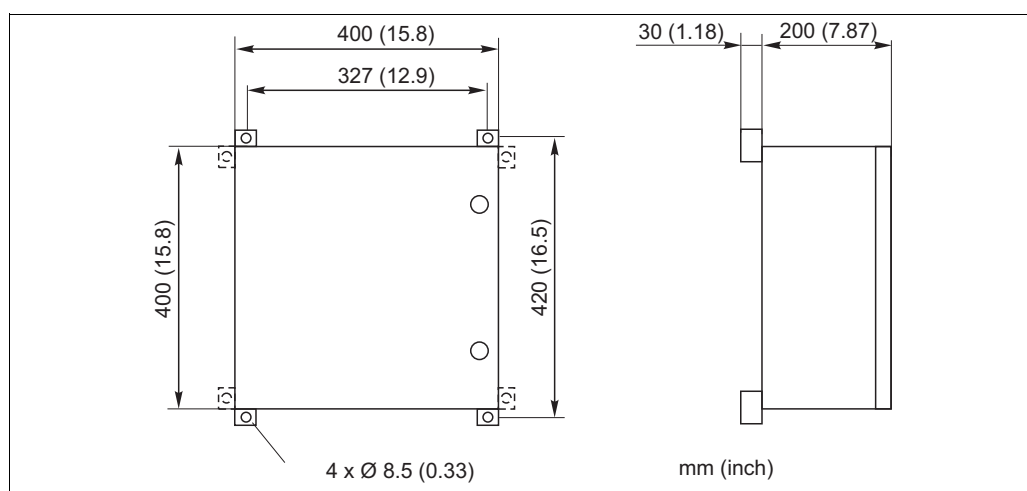

Fig. 7: Control box dimensions, left front view, right side view

Depending on the version, the control box is delivered with two clips for rail mounting or with four plastic brackets for wall mounting.

1. Mount the clips or the brackets at the holes intended for that purpose on the reverse side of the control box. For this, the clips must be fixed to the upper holes.
2. **Rail mounting:**
 - Screw the clips on the highest, horizontally-running rail pipe, right by the filter station.
 - For the box to hang straight, the supplied rubber buffer must be attached to the reverse side of the box. For this, drill a hole with a 4 mm (0.16 inch) diameter in the middle of the box position under which a lower horizontal rail pipe is situated.
 - To secure the rubber buffer, use the supplied Phillips screw.
3. **Wall mounting:**
 - Hold the box with the brackets screwed onto it against the wall and mark the holes.
 - Then drill the holes and use 8 mm screws with suitable plugs or 8 mm anchor pins (not included in scope of delivery) to secure the box to the wall.

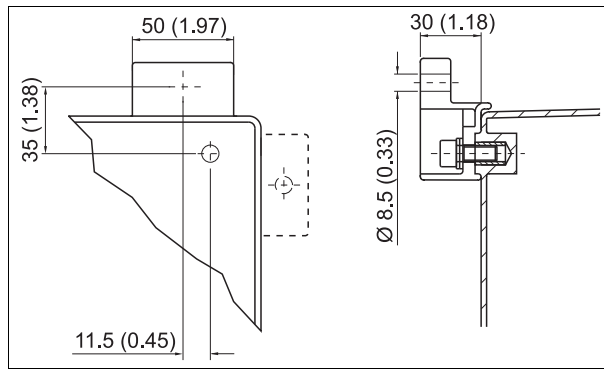

Fig. 8: Wall brackets

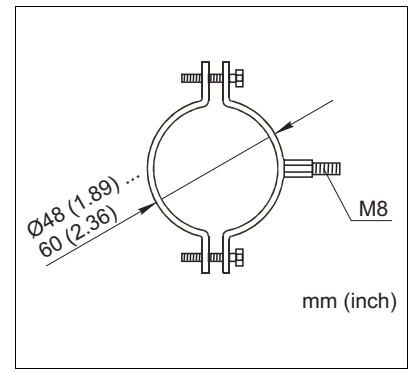

Fig. 9: Pipe clamp for rail mounting

3.3.5 Connecting the sample lines to the measuring devices

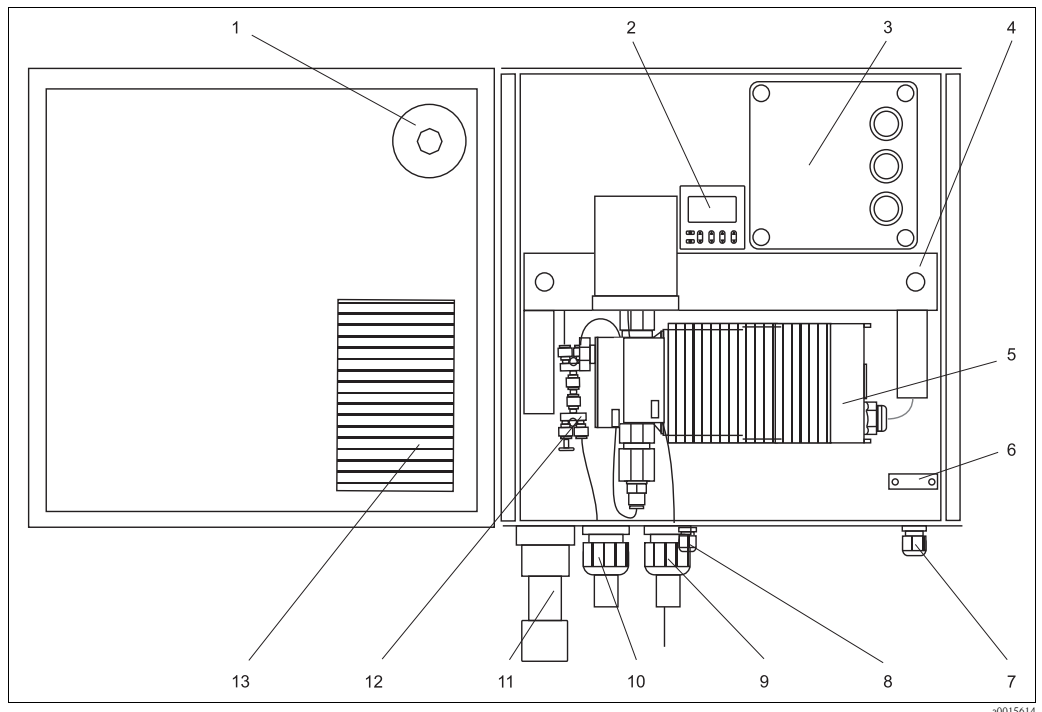



Fig. 10: Control box

- | | |
|---|---|
| 1 Manometer | 8 Vent hose gland |
| 2 Timer | 9 Gland for sample line to the analyzer |
| 3 Control unit with connection box inside | 10 Gland for filtrate line from filter |
| 4 Cable duct | 11 Pipe socket with thermal switch |
| 5 Membrane pump | 12 Y fitting |
| 6 Strain relief for power cable | 13 Housing heater |
| 7 Cable gland for power cable | |

Filtrate line from the filter elements

If the filtrate line to the filter elements has not already been connected in the factory, proceed as follows:

- Slide the filtrate hoses protruding from the filtrate line (one or two, depending on version) and the feed line of the heater cables through the hose gland (→ , item 10). Slide the spiral hose far enough into the hose gland that it is flush inside and then tighten the hose gland.
- Cut the filtrate hoses such that you can insert them comfortably into the Y fitting plug-in connectors (item 12).

Sample line to the measuring devices

The sample line to the measuring devices consists of a spiral jacket hose, one or two thin filtrate hoses and, depending on scope of order, an electric band heater.





Caution!

Lay hose lines such that they are protected against frost, where possible in underground cable ducts. Make sure that you do not overstretch the hose.

Electric band heater up to 20 m (66 ft), connection in the control box:

If the hoses and the electric band heater have not already been connected in the factory, proceed as follows:

1. Remove the plug from the power cable of the thermal switch (→  11, item 1) with an edge-cutter.
2. Loosen the nut on the cable gland from the end of the spiral hose.
3. Pull the thin filtrate hose first and then the thermal switch incl. its power cable through the nut.
4. Guide all the hose ends and the thermal switch through the hole for the cable gland (→  10, item 9) into the control box.
5. Insert the cable gland into the hole and screw the nut on tight.
6. Remove the foamed plastic pad from the pipe socket. Slide the thermal switch into the pipe socket, such that the end of the electric band heater is at the top and the power cable is at the bottom (→  11).
7. Push the foamed plastic pad over the thermal switch into the pipe socket in such a way that the power cable is isolated from the electric band heater.



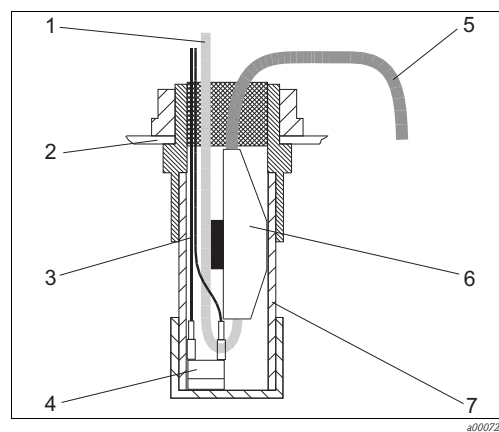

Caution!

The micro thermostat (item 4) for the housing heating system is already in the pipe socket. Be careful when inserting the thermal switch because there is not much space to work in.



- 1 Mains cable for thermal switch 230 V
- 2 Control box bottom
- 3 Cord 24 V
- 4 Micro thermostat 24 V
- 5 Band heater 230 V
- 6 Thermal switch (orange)
- 7 Pipe socket

Fig. 11: Pipe socket

8. Guide the power cable for the thermal switch from the left into the cable duct (→  10, item 4) to the connection box (item 3).
For electrical connection, please read the chapter “Wiring”.
9. Unscrew the splash protection cap (→  12, item 1) from the membrane pump.
10. Guide the filtrate hose (item 2) from below through the left-hand bore in the splash protection base (item 4).
11. Cut the filtrate hose such that you can insert it comfortably into the plug-in connector of the pressure connection (item 3).
Ensure that you push the hose all the way in the plug-in connector. You must overcome a pressure point in so doing.
12. Pull the filter hose back far enough so that it runs in a relatively narrow bend at the top (→  12).
Make sure that you do not bend the hose.
13. Screw the splash protection cap back on.
14. Now lay the sample line (spiral jacket hose incl. filtrate line and electric band heater) to the measuring devices.
Where possible, use available cable ducts or empty underground pipes. With the corresponding order, the filtrate hose is protected by the electric band heater over the entire area exposed to frost.

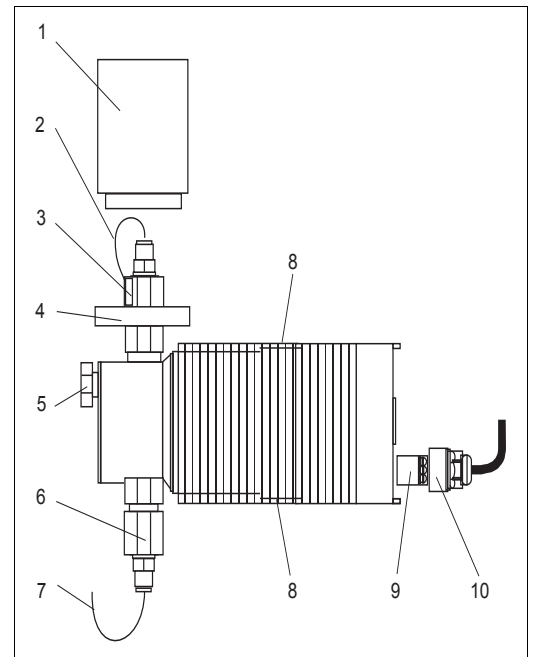

Fig. 12: Membrane pump

- | | |
|----|--|
| 1 | Splash protection cap |
| 2 | Filtrate hose to the measuring devices |
| 3 | Pressure connection with plug-in connector |
| 4 | Splash protection base |
| 5 | Vent screw |
| 6 | Suction side with plug-in connector |
| 7 | Filtrate hose from filter |
| 8 | Allen fixing screws |
| 9 | Power connector |
| 10 | Screw cap |

Electric band heater over 20 m (66 ft):

Electric band heaters over 20 m in length are available as special accessories. The connection value for such electric band heaters is too high to connect them in the control box. Consequently, they have to be connected in the analyzer compartment. Installation instructions are provided with the electric band heater.

3.4 Post-installation check

- After installation, check that all connections are fitted tightly and are leakage resistant.
- Ensure that the hoses cannot be removed without effort.
- Check all hoses for damage.

4 Wiring

4.1 Electrical connection



Warning!

- The electrical connection must only be carried out by a certified electrician.
- Technical personnel must have read and understood the instructions in this manual and must adhere to them.
- Ensure that there is no voltage at the power cable **before** beginning the connection work.

4.1.1 Wiring diagram

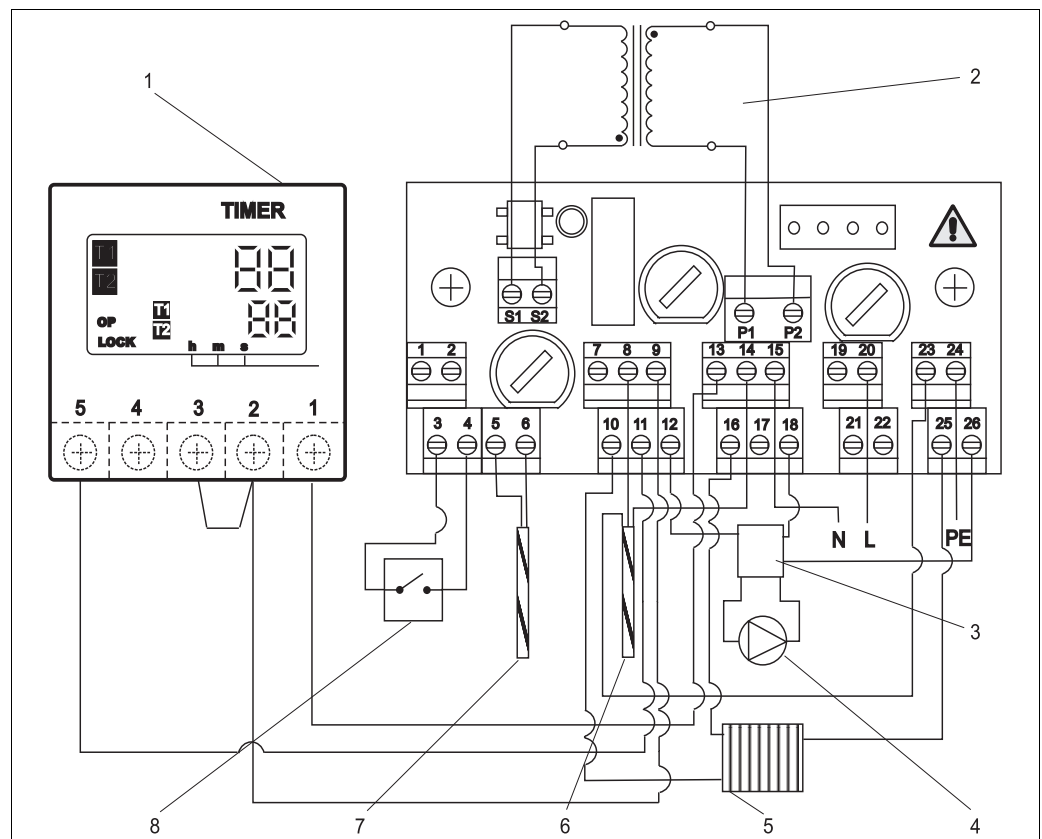

Fig. 13: Wiring diagram

1	Timer	4	Pump	7	Filtrate hose heater 24 V AC
2	Transformer	5	Housing heater	8	Micro thermostat 24 V
3	Line filter	6	Band heater 240 V AC		

T	Assignment	T	Assignment	T	Assignment
1	not connected	10	Phase L housing heater	19	not connected
2	not connected	11	Phase L from timer T5	20	Phase L mains supply
3	24V to micro thermostat	12	Phase L line filter pump	21	not connected
4	24V from micro thermostat	13	Zero conductor, timer T1	22	not connected
5	24 V to hose heater	14	Electric band heater zero cond.	23	PE electric band heater
6	24V from hose heater	15	Mains supply zero conductor	24	PE mains supply
7	not connected	16	Housing heater zero conductor	25	PE housing heater
8	Phase L electric band heater	17	not connected	26	PE line filter pump
9	Phase L to timer T2 and 3	18	Zero conductor, line filter pump		

For power supply:

You have to connect terminals 15, 20 and 24.
All other connections have been made at the factory.

For electric band heater connection:

You have also to connect terminals 8, 14 and 23 if using an electric band heater for the sample line to the analyzer (discharge side of the pump).

The heater for the hose to the suction side is included in versions CAT430-***A**. The connections (terminals 5 and 6) have been made at the factory.

4.1.2 Power supply**Caution!**

- A suitable circuit breaker must be provided by the customer. It must be placed directly upstream of the supply cable for the device.
- The device's power cable must be protected with a 30 mA error current protective switch (Ground Fault Circuit Interrupter, GFCI).

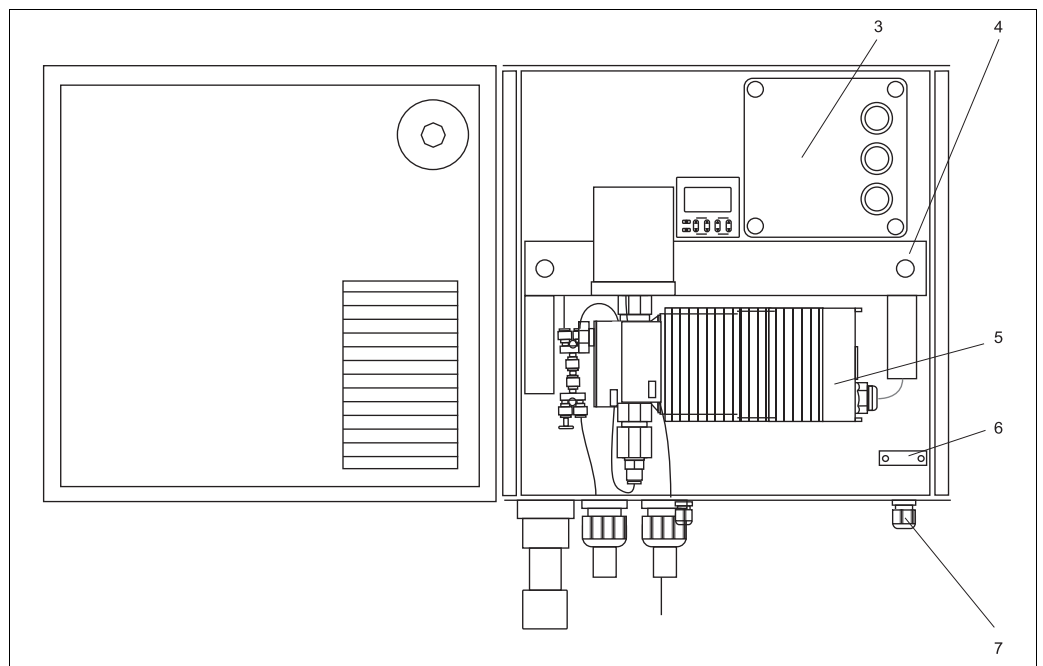

Fig. 14: Control box

- 3 Control unit with connection box inside
- 4 Cable duct
- 5 Membrane pump
- 6 Strain relief for power cable
- 7 Cable gland for power cable

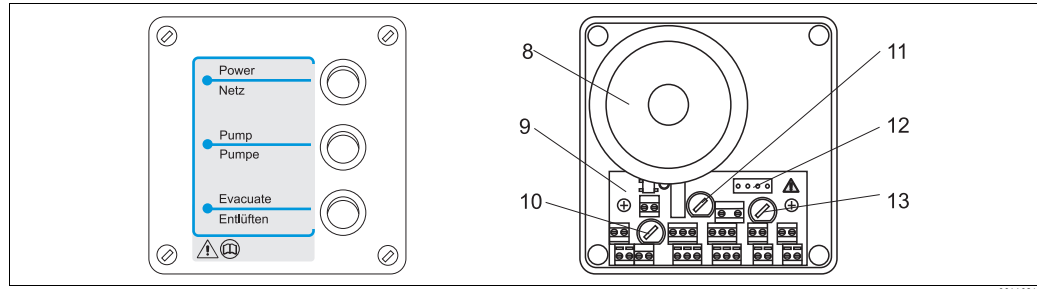







Fig. 15: Connection box: left cover, right inside the box

- 8 Transformer 24 V / 2A
- 9 Terminal block
- 10 Safety fuse for 24 V circuit 2.5 A 5 x 20 mm (0.20 x 0.79")
- 11 Safety fuse for pump 0.5 A 5 x 20 mm (0.20 x 0.79")
- 12 4-pole connection
- 13 Safety fuse for entire device 2.5 A 5 x 20 mm (0.20 x 0.79")

1. First of all, remove the cover on the cable duct (→ , item 4) and unscrew the cover of the connection box (item 3).
2. Disconnect the 4-pole connection (→ , item 12) between the cover and terminal block and secure the cover.
3. Guide the power cable through the cable gland (→ , item 7) into the pump box. Pull the cable from below right through the cable duct and into the connection box.
4. Shorten the cable to the appropriate length and remove the sheathing to a length of 40 mm (1.58").
5. Connect the wires to terminals 15, 20 and 24 (→ , 13).
6. Secure the cable with the strain relief (→ , item 6).

4.1.3 Connecting the optional hose trace heating system

If not connected at the factory:

1. Pull the cable of the 24 V hose heater (filtrate line from filter) from the left through the cable duct and into the connection box.
2. Connect the wires to terminals 5 and 6 (→ , 13).
3. Pull the supply lead of the orange thermal switch on the 230 V electric band heater (filtrate line to measuring device) from the left through the cable duct to the connection box.
4. Shorten the cable to the appropriate length and remove the sheathing to a length of 40 mm (1.58").
5. Connect the wires to terminals 8, 14 and 23.

4.2 Post-connection check

Checks	Remarks
Supply voltage matches the specifications on nameplate?	230 V AC / 115 V AC
The mounted cables slack and not twisted?	
Is the strain relief for the power cable correctly installed?	
All the cable entries installed, tightened and sealed?	
All cable entries mounted downwards or sideways?	cable loops downwards: water drains off
Are the covers of the cable duct and connection box correctly installed and the fixing screws tightened?	The connection box and cable duct must not be accessible without the use of a tool.

5 Operation

5.1 Operation and commissioning

The following chapters provide you with information on the sample preparation unit's operating elements and explain how to make settings. In Chap. 6, "Commissioning", you will find the procedure for initial start-up and for daily operation.

5.2 Display and operating elements

Main switch

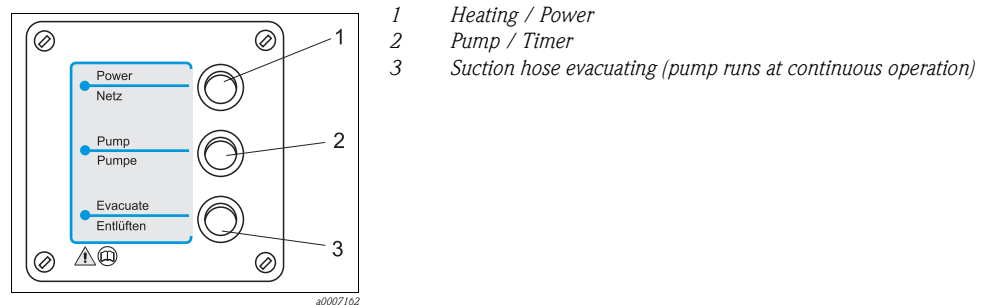

Fig. 16: Cover of connection box

Timer

A multifunctional timer controls the CAT430. When CAT430 is delivered, the timer is ready to use installed and connected.

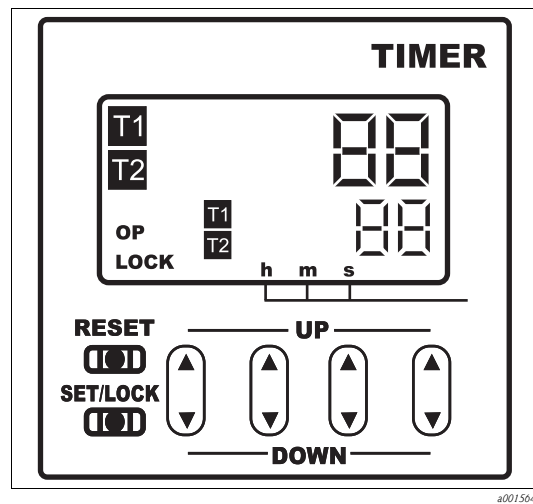

Fig. 17: Timer

5.3 Local operation

5.3.1 Cycle times

For reliable operation and achievement of long rinsing intervals, sufficient pause times between the pumping times are necessary.

The pause times depend on the number of filter elements and on the pumping capacity of the pump. The factory-set values for pumping (On) and pause times (Off), as well as the fluid quantities per pumping cycle are displayed in the following table.

Number of Filter element	On / Off [s]	Fluid quantity per cycle [ml]
1	10 / 50	5
2	20 / 40	10



Note!

In principle, you can make other settings for the cycle times.

Extending the pump time with constant pause times tends to result in shorter rinse intervals.

Therefore, you should check whether this is acceptable for your application.

5.3.2 Pump capacity

There are two rotary knobs on the right side of the pump to set the following:

1. Stroke length (large knob, front):
Depending on the number of filter elements, here you set:
 - 50% (for one filter element)
 - 100% (for two filter elements)



Caution!

The stroke length may only be adjusted when the pump is running.

2. Clock pulse frequency (small knob, rear):
Always set 100% here (clockwise to the right limit stop).

5.3.3 Timer setting

The timer controls the times when the pump is switched on and off.

When the pump is switched on the T1 fields are lit or flash red and yellow on the display, as does the OP message on the bottom left of the screen.

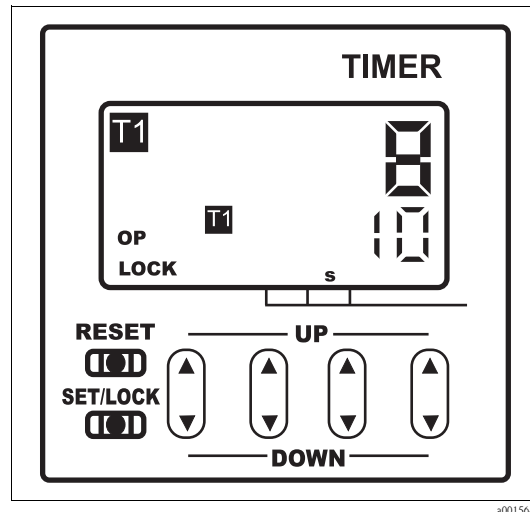

Fig. 18: Timer

The red number at the top displays the switch-on time that has already elapsed while the yellow value at the bottom displays the target value for the switch-on time. All values are full seconds. When the pump is switched off the T2 fields are lit or flash, as do the actual and target values for the switch-off time. The OP message is not displayed.

The optimum switch cycle and the time values are normally already preset for the CAT430 when the device is delivered from the factory. However, you might need to alter the settings if the process conditions change or a timer has to be replaced.

You can make the following settings:

Pump switch-on and switch-off times

Using your fingernail or a small screwdriver, press the yellow SET/LOCK button on the bottom left while simultaneously pressing the blue rocker switch (located right beside the SET/LOCK button) up or down. The "LOCK" message on the bottom left of the display disappears and the device is in the programming mode. You can ignore the actual time highlighted in red on the screen.

By pressing the SET/LOCK button a second time, you can switch between the set value for the switch-on time (yellow T1 field is lit) and for the switch-off time (yellow T2 field is lit). The yellow value indicates the set value currently set.

You can change the set value by changing each individual position using the individual rocker switches located under the display area. Press the UP arrow to increase the value and the DOWN arrow to decrease the value. Therefore in order to extend the switch-on period from 10 seconds to 20 seconds, for example, you must press the UP arrow of the second rocker switch from the right once only and the yellow T1 field must be lit.

Once both times are configured correctly, you must set the settings by pressing the SET/LOCK key and the adjacent rocker switch simultaneously. "LOCK" appears on the display again.

Time range

The correct time range for the switch-on and switch-off time is between 1 and 9999 seconds. It is normally set at the factory and should not be changed. To check the time ranges, you first have to remove the timer (see the "Replacing the timer" section). A flap is located on the right-hand side of the housing which you can open using your fingernail or a small screwdriver.

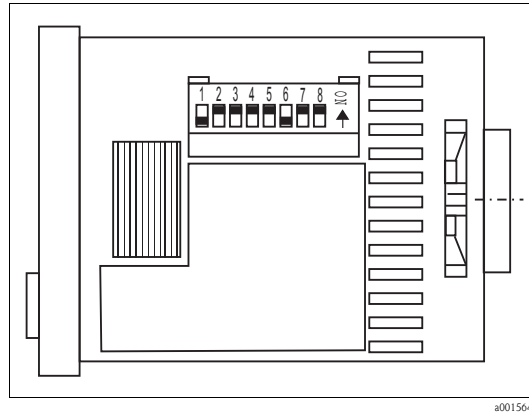

Fig. 19: Timer

When the timer is set correctly, switches 1 and 6 must be switched on - i.e. in the top position (→ Fig. 19) - while all the other switches are in the bottom position. To change the time range, e.g. from seconds to minutes, you must set switches 1-3 for the switch-on time and switches 6-8 for the switch-off time as indicated in the written instruction under the switches.

Operating mode

The timer must be configured as an asymmetric clock, starting with the switch-on phase. In order to check this configuration, you must first switch to the programming mode by simultaneously pressing the SET/LOCK button and the adjacent blue rocker switch. The "LOCK" message on the display must disappear.

If you now simultaneously press the SET/LOCK button and the second rocker switch from the right, "Pu-c" must appear on the display for approx. 2 seconds. If another message appears, please simultaneously press the SET/LOCK button and the rocker switch on the far right. Then release both buttons. Now press the rocker switch on the far right until Pu-c appears on the display. Select this setting by pressing the yellow RESET button located above the SET/LOCK button.

Then return to the secured mode by simultaneously pressing the SET/LOCK button and the blue rocker switch directly beside it.

6 Commissioning

6.1 Function check



Caution!

Check that all connections have been made correctly. Especially check that all hose connections are firmly attached, so that no leakages occur.

Pay particular attention to the hose connections on the membrane pump and ensure that the splash protection cap is screwed back on.

6.2 Switch-on

6.2.1 Initial start-up

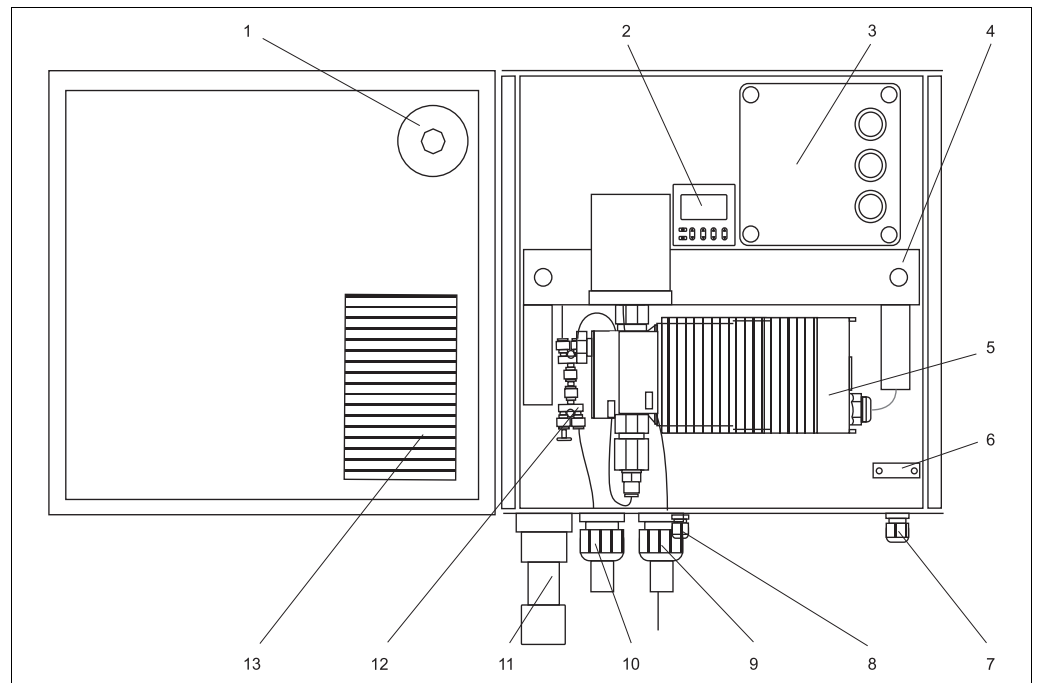



Fig. 20: Control box

The vent hose for ventilating the pump is already connected at the factory. The bottom part of the hose projects slightly out of the gland (→ , item 8).



Caution!

If sample leaks can cause damage, place a bucket under the hose.

6.2.2 Power switch

Make sure that the rotary knob for the stroke frequency of the pump (small rotary knob on the right-hand side of the pump) is set to 100% (right stop in clockwise direction).

You use the rocker switches on the cover of the connection box for the switching operations:

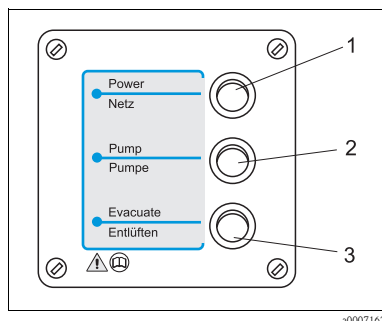

- 1 Switches on the housing heater and the heater cable in the filtrate line
- 2 Activates the timer and pump, starts operation with factory settings (initial start-up) or with individual settings
- 3 Continuous operation of the pump, evacuates the filter elements and filtrate line

Fig. 21: Cover of connection box



Note!

- To start the entire system immediately, switch on "Power" and "Pump".
- Note that when "Pump" is switched on, the pump starts to feed immediately.



Caution!

- If you are starting the machine in frosty conditions, only switch "Power" on first. Wait approx. 30 minutes before you start the pump. This time is needed to bring the filtrate hoses and the pump box above 0 °C (32 °F).
- Continuous operation of the pump (lower switch) is necessary above all for degassing the filter elements and the filtrate hoses. Switch the continuous operation on for approx. 10-15 minutes during commissioning. The vacuum at the manometer must not be larger than 0.4 bar (6 psi). Otherwise, stop the continuous operation and switch it on again when there are many air bubbles in the filtrate hose.



Switch-on

Fig. 22: Membrane pump

1. Switch on the "Power" switch.
2. Switch on the "Evacuate" switch.
3. Open the vent screw (→ , item 5) by turning the knurl counterclockwise.
4. Wait until the flow of sample supplied from the vent hose is free of bubbles.
5. Set the "Evacuate" switch back to "0" (off).

**Caution!**

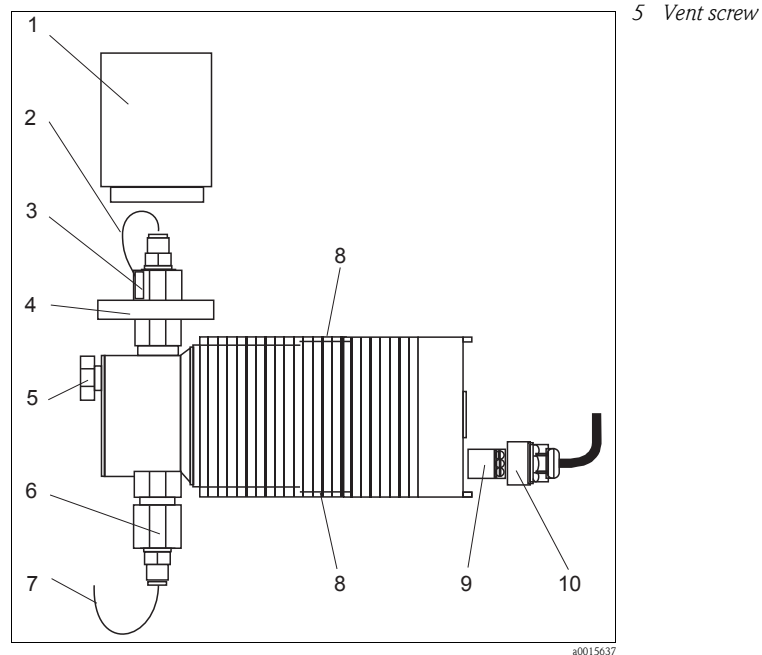
After commissioning, always switch "Evacuate" off. Otherwise the filter plates will become clogged in a short period of time.

6.3 Checking the sample transportation

1. Close the vent screw (turn clockwise).
2. Measure the time that the sample requires from switching on the pump until arriving in the collecting vessel at the measuring devices.

This time is the minimum delay time that passes between taking the sample and measurement. You shorten the delay time by extending the operating time or stroke length of the pump.

**Note!**

At the same cycle duration, the delay time drops by a third when the operating time is increased by 50%.

6.4 Checking the sampling quantity

1. Measure the amount of sample arriving at the devices by placing a 100 ml (3.4 fl.oz.) graduated beaker under the filtrate hose (→  23, item 5). Measure the amount of sample that is supplied within the period of 10 minutes.
2. Calculate the filtrate output per hour.
Depending on the number of filter elements (one, two or four) and the pump design, the filtrate output must be 250 or 500 ml/h (0.065 or 0.13 gal/hr).
3. If necessary, correct the filtrate output by changing the operating time and/or stroke length of the pump.

6.5 Setting the collecting volume

In the following figure the collecting vessel is shown on the measuring device side.

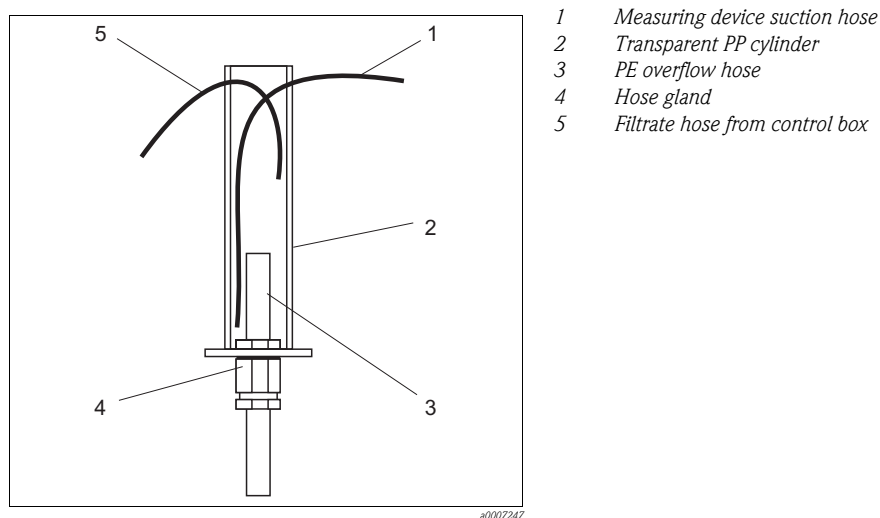

Fig. 23: Collecting vessel (measuring device side)

The overflow hose (item 3) must be set such that the measuring devices suck just enough sample out of the collecting vessel within a pumping cycle that the bottom is still covered and thereby no air is sucked in.

For measuring devices working intermittently the collecting volume must always be larger than the amount that can be sucked in by the measuring device in one go.

This is how to set the collecting volume:

1. Loosen the hose gland (item 4).
2. Set the length of the overflow hose (item 3) in the collecting vessel such that the desired volume is reached.
3. Tighten the hose gland again and check that it is leakage-resistant.



Note!

- If you use CAT430 for preparing samples for analyzers of the CA71 series, please use the collecting vessel of the analyzer with or without level monitoring.
- If a nitrate sensor with flow assembly is installed in the filtrate line, you have to install the collecting vessel after the nitrate sensor.

7 Maintenance

7.1 Maintenance activities

All maintenance activities that have to be carried out during normal operation are described below.

7.1.1 Cleaning the filter elements

1. Please switch the pump off first (middle switch on the connection box) and then pull the entire filter unit out of the water by the plastic chain.
2. Hang the chain up on the rail or another suitable place so that you prevent the filter unit from falling back into the basin.
3. Now wash down the filter membranes with a water hose. The cleaning effect can be seen when the brownish coating dissolves from the bright membrane surface.



Caution!

Danger of damaging the membrane if the membrane is washed down incorrectly!

It is best to use a garden hose with a spray nozzle to wash down the filter elements. If a firehose is used, set the stream somewhat wider in order to avoid damaging the filter elements.

If no water supply is available, a high-pressure cleaner with water canister can also be used to wash down.

4. After washing down, check whether the membrane is damaged.
5. Finally, lower the filter unit back into the basin by the chain. Ensure that the filter elements are completely under the water level again.

Normally, no chemicals are required for cleaning the filter elements. At measuring points with a high grease and protein content, however, it can be necessary to chemically treat the membranes from time to time.



Warning!

Caustic! Risk of injury to skin and eyes.

The following tasks should only be performed by staff specially trained in the handling of chemicals and authorized to perform such work by the owner/operator.

Be sure to wear protective gloves and protective goggles when handling hydrochloric acid (HCl) and hydrogen peroxide (H₂O₂).

Use a mixture of 200 ml (6.8 fl.oz.) 30% H₂O₂, 1 l (34 fl.oz.) water and 30 ml (1 fl.oz.) concentrated HCl:

1. Wash the filter elements down first with water.
2. Then apply the solution to the filter elements with a plastic watering can with spraying nozzle.
3. Repeat the procedure three times at intervals of 5 minutes.



Caution!

Ensure that the filter membranes do not dry out because otherwise they will be irreparably destroyed!

4. Then wash the filter elements down again with water and lower the filter unit into the basin again by the chain.

The time interval between two rinses depends to a great extent on the condition of the wastewater. It can be assumed that the maintenance interval at the sludge activation outlet of a sewage treatment plant operating normally is at least 5 weeks if the operating time of the pump compared to the values in the table in chapter "Local operation/Cycle times" is not considerably increased. In summer, however, it can even be a number of months.

7.1.2 Storage of filter elements

The membrane of all used filter elements must be kept wet.

Use the optional transportation box (→ accessories) to keep the filter elements wet.

7.1.3 Evacuating the pump

Air bubbles can occur in the dosing head of the pump after installing a new filter element or in the event of vacuum pressure as of 0.6 bar (9 psi). The air bubbles have an impact on the filtrate feed and must be removed.



Note!

A large vacuum pressure can be caused by buildup on the filter elements. For this reason, check and clean the filter elements first, if necessary.

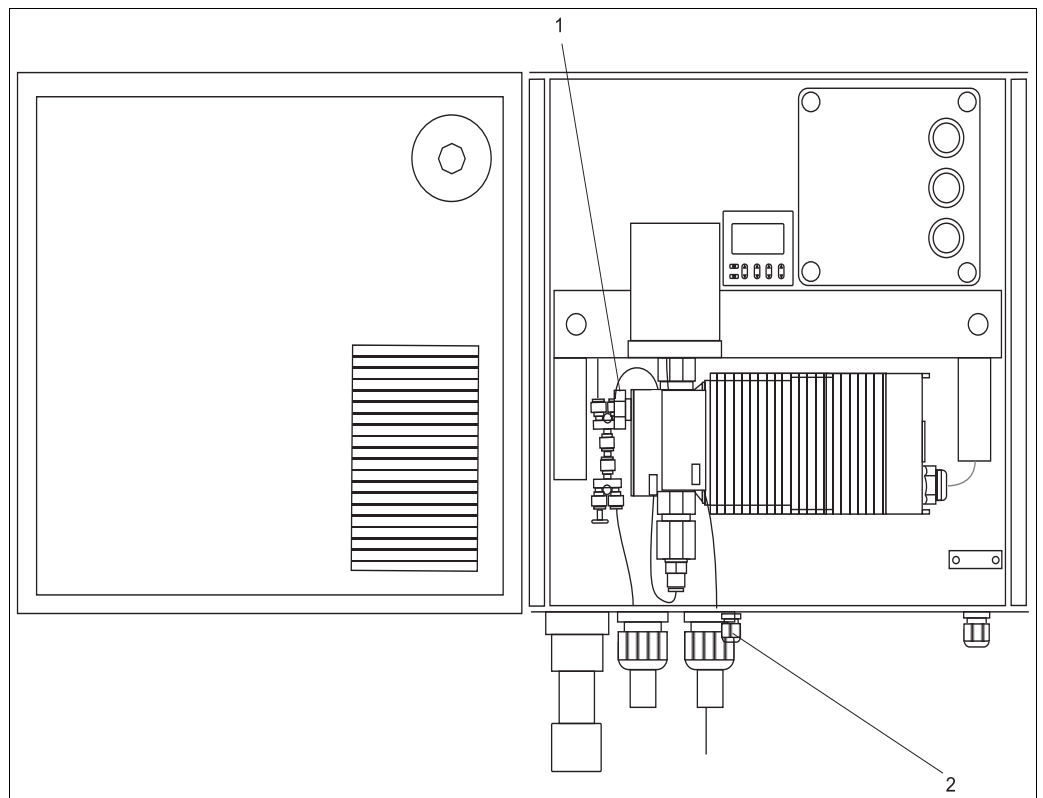

Fig. 24: Control box

- 1 Vent screw
- 2 Vent hose gland



Caution!

If sample leaking from the vent hose (item 2) can cause damage, please place a bucket under the device.

1. Open the vent screw (item 1).
2. Switch on the "Evacuate" switch and run the pump until no more air bubbles come out of the vent hose.
3. Close the vent screw again.
4. Switch off the "Evacuate" switch.

7.1.4 Replacing filtrate hoses

In the course of a few months a coating builds up in the transparent PVC filtrate hoses in the control box despite ultra filtration. It is not worth cleaning them. Replace the hoses as described below.

1. Switch off the pump.
2. Pull all transparent hoses out of the black PP plug-in connectors, by pressing the retaining ring of the respective plug-in connector against the pull out direction of the hose into the connector.
3. Cut hose pieces to the right size, according to the old hoses, out of the 4/2 mm (0.16/0.08 inch) PVC hose.
4. Slide the ends of the hose all the way into the plug-in connectors.
When inserting the hoses into the O-ring seals, a pressure point must be overcome.

Should the filtrate hoses become dirty again after a short time, it is possible that a filter element is defective and must be replaced.

7.1.5 Rinsing the sample hose between control box and measuring devices

In the course of time, a coating also builds up in the sample hose between the control box and measuring devices, that can result in nitrification effects and material wear. Consequently, this leads to incorrect measurement results.

To prevent these effects, you must chemically rinse the sample hose approx. every 6 weeks.



Warning!

Caustic! Risk of injury to skin and eyes.

The following tasks should only be performed by staff specially trained in the handling of chemicals and authorized to perform such work by the owner/operator.

Be sure to wear protective gloves and protective goggles when handling hydrochloric acid (HCl) and hydrogen peroxide (H₂O₂).

Use a mixture of 200 ml (6.8 fl.oz.) 30% H₂O₂, 1 l (34 fl.oz.) water and 30 ml (1 fl.oz.) concentrated HCl.

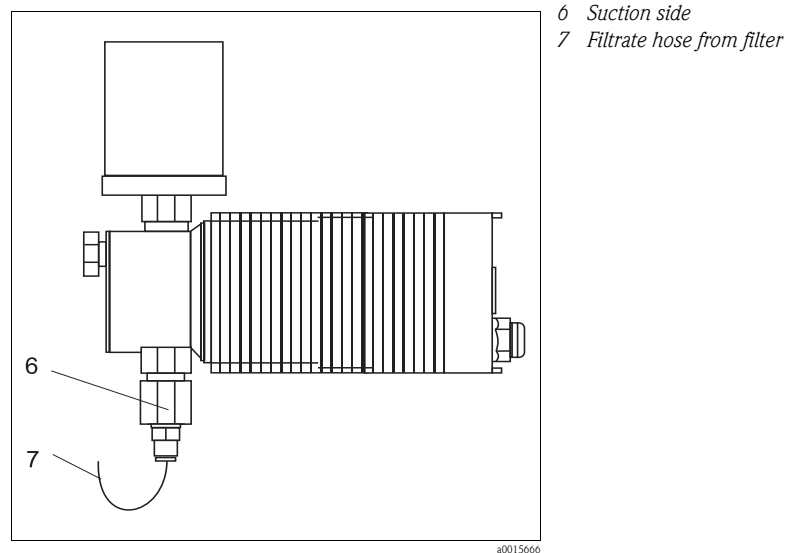

Fig. 25: Membrane pump

1. Switch all of the connected measuring devices to standby mode.
2. Disconnect the filtrate hose (item 7) from the pump's suction side (item 6):
3. Instead of the suction hose, connect a 50 cm (1.6 ft) long PE hose and insert the other end of this hose in a 500 ml (17 fl.oz.) bottle of cleaning solution.
4. Leave the CAT430 run for 20–30 minutes with the cleaning solution.
5. Then remove the PE hose once more and reconnect the suction hose to the plug-in connector of the pump.
6. Leave the CAT430 run for another 20 minutes with filtrate, until the cleaning solution has been completely removed from the system.
7. Switch on the measuring devices once again.

7.2 Repairs



Warning!

Work on electrical components must only be carried out by authorized and trained technical personnel.

Before beginning work, switch the fuses for the complete machine off. The fuses are provided by the customer.

7.2.1 Replacing a filter element

The filter element membranes have a service life of approx. 2 years, depending on operating conditions. After this time or in case of mechanical damage, the membrane becomes permeable to contamination. This can be detected by turbidity of the sample and by strong soiling in the relevant PVC filtrate hose or in the corresponding duct of the filtrate Y-piece in the control box. In this case, the defective filter element(s) have to be replaced.

Proceed as follows:

1. Switch off the "Pump" switch.
2. Pull the filter unit out of the water and rinse the entire unit thoroughly with a jet of water.
3. Check the membranes for mechanical damages, such as scratches, cracks or separations of the membrane layer from the carrier layer. In these cases, you must replace the filter element.
4. Pull the filtrate hose of the affected filter element out of the threaded elbow joint on the reverse side of the element.
Press the retaining ring of the hose gland against the pull out direction of the tube.
5. Loosen both PVC screw caps on the front side of the element.



Caution!

Do not allow the coupling nut or filter element to fall into the activated sludge basin.

6. The defective filter element can now be easily removed and replaced with a new one.
7. Mount the new filter element as described in Chapter "Installation instructions".

7.2.2 Replacing the device fuses

On the terminal PCB in the connection box, there are 3 circuit fuses 5x20 mm (5x0.79 inch) (→  15).

The fuses blow if the current flow is too high.

Before replacing a fuse, you must first determine what caused the fuse to blow.



Warning!

Determining what caused the fuse to blow must only be carried out by authorized and trained technical personnel.

Before beginning work, switch off the complete system with the circuit-breaker provided by the customer!

To replace a fuse, proceed as follows:

1. Unscrew the four plastic screws on the corners of the connection box cover and remove the cover.
2. Press the screw cap of the fuse and turn it approx. 45° counter-clockwise.
3. Remove the fuse and replace it with another one. Screw the cap back on.
4. Screw the cover of the connection box back on.
5. Switch the systems back on and check that the CAT430 functions properly.

7.2.3 Replacing the timer

It is assumed that the timer is defective if, despite mains voltage being present and the top or middle switch on the connection box being switched on, the display is blank or the relay for the pump does not switch as intended in the cycle.



Warning!

Before replacing the timer, be sure to switch off the circuit breaker, provided by the customer, for the entire machine.

1. Open the cable duct.
2. Release the two fixing screws on the timer brackets on the left and right of the timer and remove the timer.
3. Release the cables on the rear of the timer and remove the timer.
4. When connecting the new timer make sure you connect the connecting cables (→  13) in the correct order. Please note that the numbering of the timer terminals starts with terminal number 1 on the left, as viewed from the rear of the timer. Numbers are embossed on the terminals. These numbers are located under the screws.
5. Using the screws, secure the timer to the carrier plate again.

7.2.4 Cleaning and replacing check valves



Note!

Only use genuine spare parts.

Crystalline buildup on the ball seat of the check valves has an impact on the feed capacity of the membrane pump.

Rinsing the filtrate hose between the control box and the device(s) should eliminate this buildup. If the pump still does not feed correctly after rinsing and at 100% clock pulse frequency and 100% stroke length (both rotary knobs on the right-hand side of the pump turned to the right as far as they can go), you have to remove the valves and replace them.

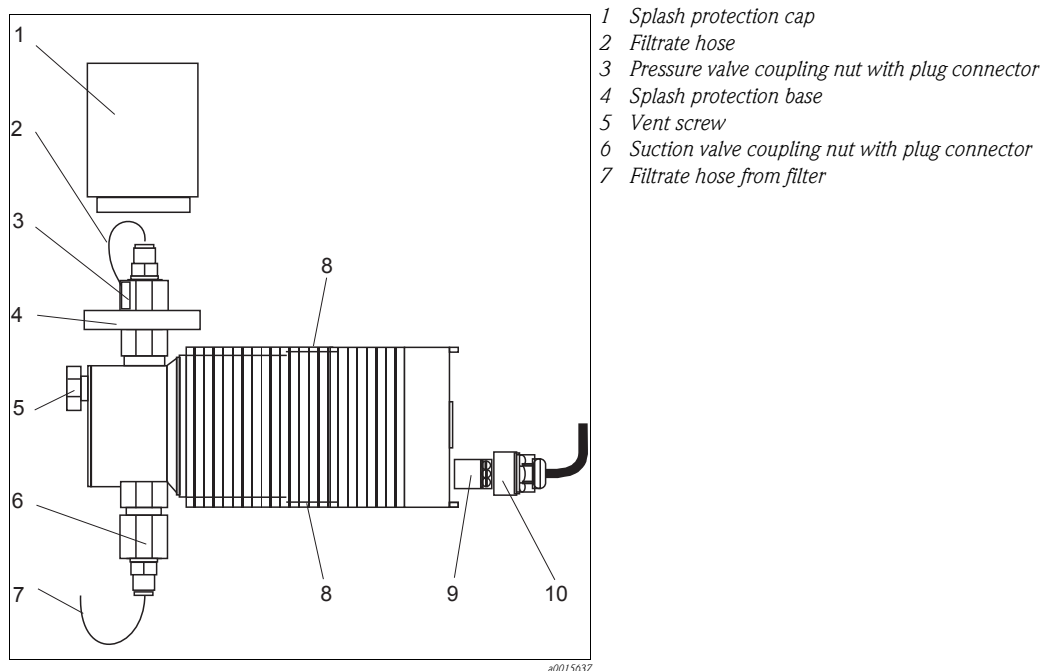

Fig. 26: Membrane pump

Preparing for valve replacement

1. Switch off the pump.
2. Unscrew the splash protection cap (item 1).
3. Pull the filtrate hoses (items 2 and 7) out of the plug-in connectors at the suction and pressure valve.
4. Unscrew the coupling nuts from the suction and pressure valve (items 3 and 6).
5. Remove the splash protection base (item 4) from the pressure valve.



Note!

- The pressure and suction valves are different. For this reason, disassemble and clean the valves one after another, and not at the same time. This avoids any mix up.
- Only use genuine spare parts.

Pressure valve

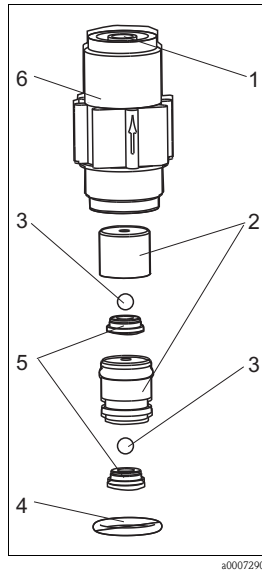



Fig. 27: Pressure valve

- 1 Opening
- 2 Valve inserts
- 3 Valve balls
- 4 O-ring
- 5 Valve seats
- 6 Pressure connection

1. Screw the valve out of the pump head.
2. Remove the O-ring (→  27, item 4) from the pump head with a small screwdriver. If replacing the valve, continue with Point 9.
3. Press the valve inserts (item 2) out of the valve by guiding a suitable tool (e.g. an Allen key) through the opening of the pressure connection (item 1).
4. Use the screwdriver to remove the valve seats (item 5). In doing so, let the valve balls (item 3) fall onto a piece of paper so they can be found easily again.
5. Clean all parts thoroughly with water.
6. Replace damaged parts (see "Spare parts").
7. Drop the valve balls into the valve seats and press on the valve inserts.
8. Press the valve inserts with the small hole in the direction of flow (arrow) into the pressure connection. Pay particular attention to the order of both valve inserts (→  27).
9. Insert the O-ring into the pump head.
10. Screw the valve into the pump head until the stop.
11. Mount the splash protection base and the O-ring again.
12. Screw the coupling nut with the plug connector onto the valve.
13. Insert the filtrate hose (to the device) into the plug connector.
14. Screw the splash protection cap back on.

Suction valve

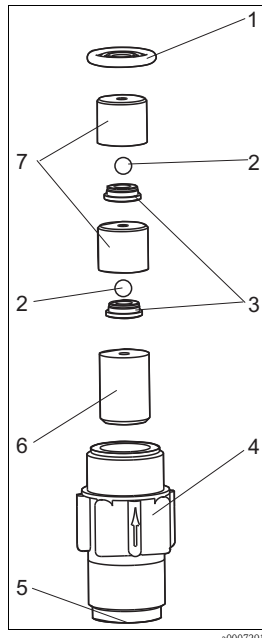



Fig. 28: Suction valve

- 1 Molded seal
- 2 Valve balls
- 3 Valve seats
- 4 Suction connection
- 5 Opening
- 6 Spacer sleeve
- 7 Valve inserts

1. Screw the valve out of the pump head.
2. Remove the molded seal (→  28, item 1) from the pump head using a small screwdriver. If replacing the valve, continue with Point 9.
3. Press the spacer sleeve (item 6) and the valve inserts (item 7) out of the valve by guiding a suitable tool (e.g. an Allen key) through the opening of the suction connection (item 5).
4. Use the screwdriver to remove the valve seats (item 3). In doing so, let the valve balls (item 2) fall onto a piece of paper so they can be found easily again.
5. Clean all parts thoroughly with water.
6. Replace damaged parts (see "Spare parts").
7. Drop the valve balls into the valve seats and press on the valve inserts.
8. First press the spacer sleeve and then the valve inserts with the small hole in the direction of flow (arrow) into the suction connection. Note the order: spacer sleeve and then valve inserts (both similar).
9. Insert the molded seal into the pump head.
10. Screw the valve into the pump head until the stop.
11. Screw the coupling nut with the plug connector onto the valve.
12. Insert the filtrate hose (from the filter) into the plug connector.

7.2.5 Pump sealing

If filtrate leaks out of the leak bore on the underside of the pump head (item 6), there are two possible reasons:

- a) The fixing screws of the pump head have become loose.
- b) The pump membrane is defective.

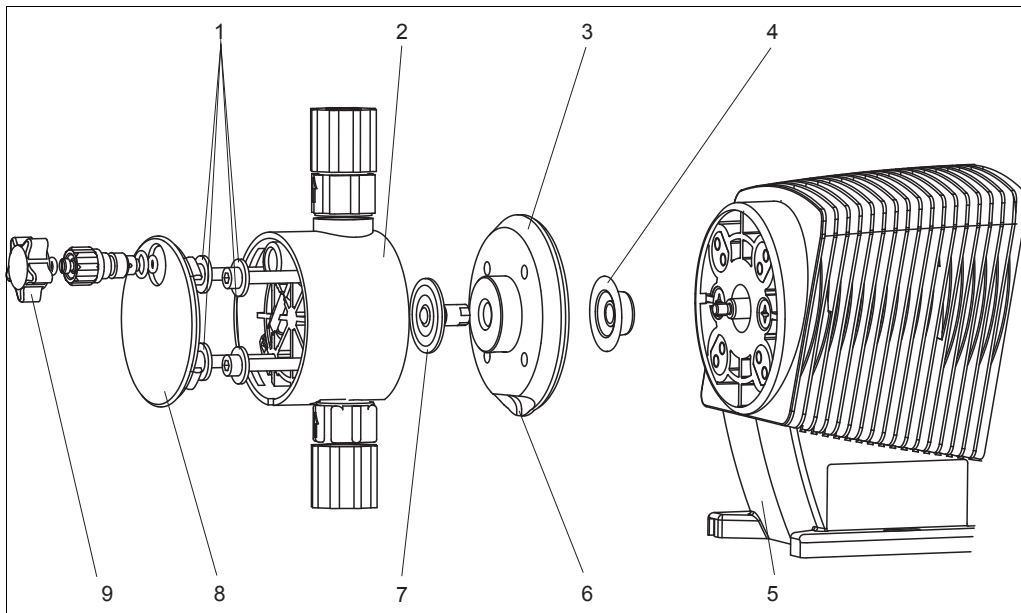

Fig. 29: Pump head and individual parts

- | | |
|-------------------|------------------|
| 1 Fixing screws | 6 Leak bore |
| 2 Pump head | 7 Membrane |
| 3 Head disk | 8 Cover plate |
| 4 Safety membrane | 9 Evacuate screw |
| 5 Pump housing | |

a) Fixing screws are loose

1. Switch the controller off.
2. Remove the handle of the evacuate screw (item 9).
3. Remove the cover plate (item 8) by levering it off with a suitable tool.





Warning!

Risk of injury

Only use a suitable tool, blunt if possible. Do not use your finger nails and ensure that you do not endanger yourself or others.

4. Tighten all four fixing screws (item 1) with the Allen key supplied (4 mm).
5. Switch on the controller and check whether filtrate still leaks out. If yes, the pump membrane is defective and you have to replace it (see b).
6. If the pump is leak-tight, reattach the cover plate and then the handle of the evacuate screw.

b) Changing the pump membrane

1. After tightening the fixing screws, the pump is still not leak-tight: Switch on "Evacuate" at the connection box of the control box.
2. Set the stroke length of the pump (big rotary knob at right) to 0 % (left limit stop).
3. Switch "Pump" and "Evacuate" off.
4. Unscrew the splash protection cap.
5. Remove the filtrate lines from the pump head (→  26, items 2 and 7).
6. Loosen and remove all fixing screws (→  29, item 1).
7. Remove the pump head.
8. Lift the membrane (item 7) at the edges so you can hold it with your thumb and index finger.
9. Turn the membrane counterclockwise to remove it from the drive axle.
10. Remove the head disk (item 3) and check the safety membrane (item 4) for damage. Replace it if necessary.
11. Only push the new safety membrane so far onto the drive axle until it is in level contact with the pump housing (item 5).
12. Mount the head disk with the leak bore (item 6) facing downwards onto the pump housing.
13. Screw the new membrane clockwise onto the drive axle. For the last rotation, hold the membrane again between your thumb and index finger and tighten it in this way. In doing so, make sure you do not twist the head disk!
14. Mount the pump head on the membrane and head disk. Make sure that the evacuate screw is on top.
15. Insert the fixing screw and tighten it uniformly and crosswise with the Allen key 4 mm (tightening torque 2.5 to 3 Nm).
16. Mount the cover plate and the handle of the evacuate screw.
17. Connect the filtrate hoses to the plug connectors again. Make sure the connection is correct: filtrate line from the filter elements at the suction valve and filtrate line to the device at the pressure valve.
18. Screw the splash protection cap back on.
19. Switch "Pump" on again.

**Note!**

Check for leak-tightness again. If the pump is still leaking, you have to replace the pump completely (see the following chapter).

7.2.6 Replacing the membrane pump

If the pump is still leaking or does not feed correctly despite the measures described, you must replace the pump and send it in for repair.

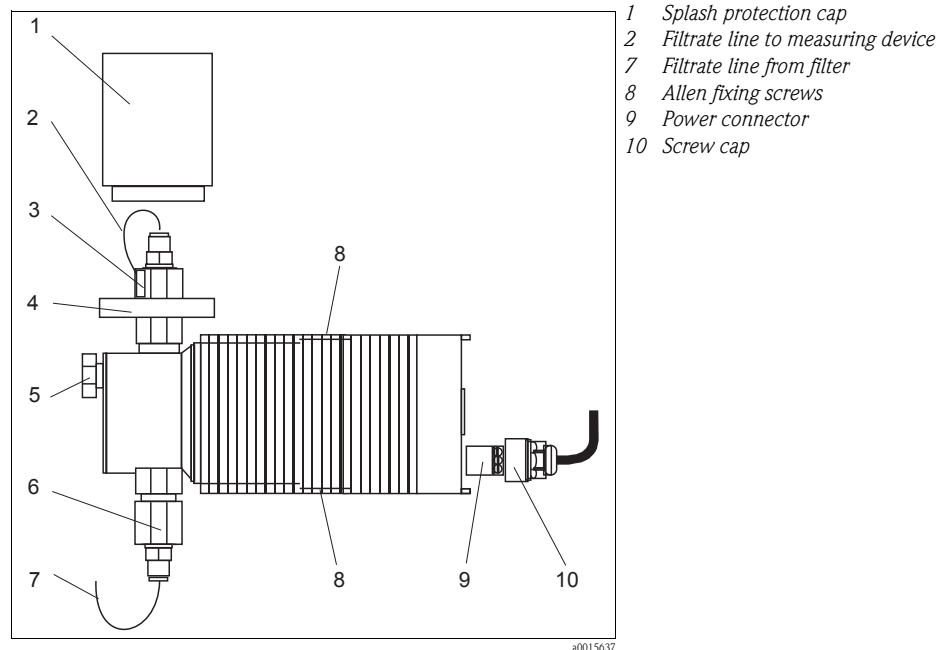



Fig. 30: Membrane pump

Removing the pump

1. Switch "Power" and "Pump" off.
2. Unscrew the splash protection cap (item 1).
3. Pull the filtrate hoses (items 2 and 7) out of the plug-in connectors on the suction and pressure connection.
4. Loosen the gland for the vent hose (→ , item 2) and remove the vent hose from the inside.
5. Remove the covers of the cable ducts.
6. Hold the pump tight with one hand and, with the other, loosen the Allen screws (item 8) at the base of the membrane pump. For this purpose, use the 200 mm Allen key with handle provided.
7. Take the pump out of the control box.
8. Unscrew the screw cap (item 10) from the power connector on the right-hand side of the pump and pull the power connector at the cable out of the nozzle.

Installing the new or repaired pump

1. Insert the power connector (item 9) into the threaded nozzle on the right-hand side of the pump as illustrated. Fit the screw cap straight on the threaded nozzle and tighten it.
2. Insert an Allen screw with washer into the lower slot at the base of the pump.
3. With one hand, insert the Allen key (200 mm) into the screw and, with the other hand, bring the pump into position in the control box.
4. Turn the screw with the Allen key and, at the same time, move the pump slightly to and fro until the screw engages the threaded hole in the carrier plate.
5. Align the pump in such a way that the screw is approximately in the center of the slot. Tighten the screw slightly.
6. Mount the second screw with washer onto the Allen key. Guide the screw through the upper slot on the pump base and also tighten it slightly.
7. Align the pump straight and tighten the screws without overtightening them.
8. Route the pump cables in the cable ducts and put the covers back on.
9. Tighten the fixing screws of the cable duct.
10. Mount the filtrate lines on the plug connector (make sure the connection is correct!).
11. Screw the splash protection cap back on.
12. Switch "Power" and "Pump" on.
13. Vent the pump if necessary (see "Evacuating the pump")

8 Accessories



Note!

In the following sections, you find the most important accessories available at the time of issue of this documentation. For information on accessories that are not listed here, please contact your responsible service department or sales center.

8.1 Filter element holders

Filter element holders

- Holder with vertical retaining slide, for basin
 - 1.50 m (4.9 ft)
 - order no. 51511353
- Holder with vertical retaining slide, for basin
 - 1.80 m (5.9 ft)
 - order no. 51511354
- Holder with horizontal retaining slide, for open channel
 - 1.50 m (4.9 ft)
 - order no. 51511373
- Holder with horizontal retaining slide, for open channel
 - 1.80 m (5.9 ft)
 - order no. 51511374

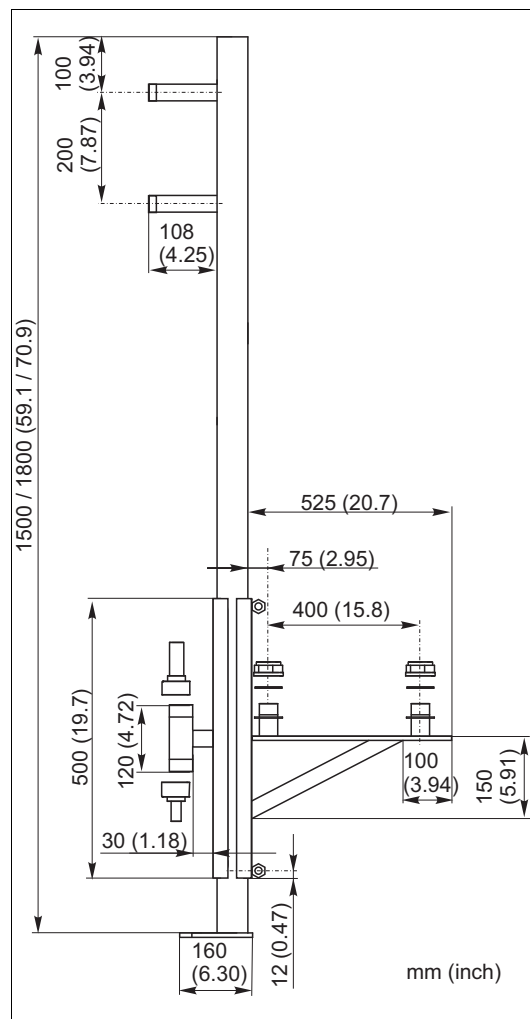

Fig. 31: Holder for open channel, side view

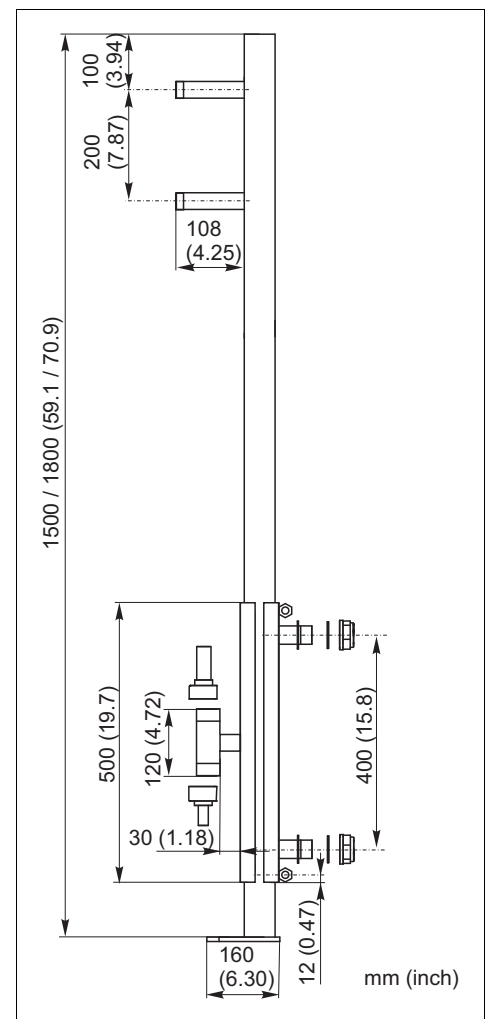

Fig. 32: Holder for basin, side view

8.2 Filter element accessories

Adapter

- for mounting a 2nd filter plate (2 adapters needed per filter plate)
- order no. 51511355

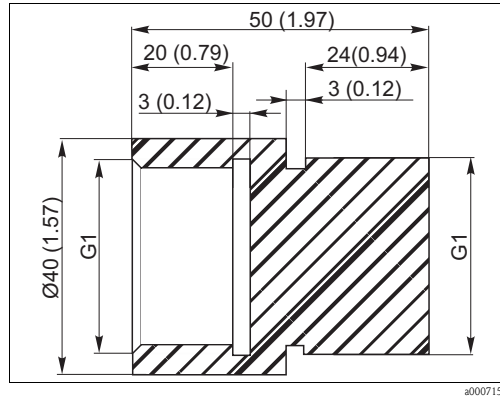

Fig. 33: Dimensions

Transportation box for filter elements

- for secure transportation resp. storage of 1 or 2 filter plates
- 500 x 400 x 50 mm (19.7 x 15.8 x 1.97 inch)
- order no. 51512477

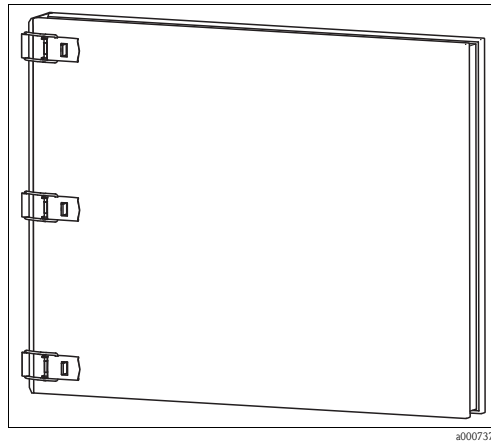

Fig. 34: Transportation box

9 Troubleshooting instructions

9.1 Troubleshooting instructions

Although CAT430 is not very prone to faults due to its simple construction, problems can, of course, not be completely ruled out.

In the following table you can find, therefore, possible faults, their causes and possible fault eliminations. The term "terminal" refers to the number of the terminal.

Fault	Possible cause	Tests and / or corrective measures
No or too little filtrate	Pump not running	<p>Ensure that on the connection box the upper and the middle switch are at "ON" or "I" and the lower switch at "OFF" or "O".</p> <ul style="list-style-type: none"> - Did you wait for the next start-up phase of the timer? - Pump switched on? Small cycle rate rotary knob on the right-hand side of the pump turned as far as it will go in the clockwise direction? - 230 V between timer connection 2 and 3 and terminal 18? No: Check cable connection between connection 2 and 3 and terminal 9. - 230 V between timer connection 5 and terminal 18 when the relay is switched on? ("OP" must be lit on the bottom left of the display) No: Timer defective, replace. - Switch on the "Evacuate" switch: 230 V between terminals 12 and 18? No: Check fuse 6 and replace if necessary. Voltage present, pump still not running? Replace pump.
	Pump running	<ul style="list-style-type: none"> - Are the stroke frequency and stroke length set correctly? - Is filtrate leaking out under the pump head? Tighten fixing screws or replace membrane. - Air in suction hose or pump head? Clean filter elements and vent pump. - No filtrate or too little? <ul style="list-style-type: none"> - Switch controller off. Disconnect the filtrate hose from the pressure side of the pump (top) and connect the supplied hose piece. - Switch on controller. Does filtrate come? - Measure the amount with a measuring beaker. - No filtrate or too little? Check the vacuum pressure at the pressure gauge! - No vacuum pressure or less than -0.2 bar? Buildup in the valves. First rinse and if this does not solve the problem take it apart and replace parts! - More vacuum pressure than -0.7 bar? Filter element or filtrate hose blocked! First clean filter element and if this does not help disconnect the filtrate hose from the threaded elbow joint on the rear of the filter element. - Vacuum pressure now 0? Replace filter element! - Vacuum pressure still more than -0.7 bar? Filtrate hose blocked! Causes are frost or soiling. Frost: see below. Soiling: Using the connection piece supplied, clear the filtrate hose with compressed air. - All checks listed above carried out and poss. faults rectified? Check the filtrate quantity fed. - Switch off controller, reconnect filtrate hose, switch on controller. - Is the measured filtrate quantity reported at the devices? - No: Frost or soiling in sample line to the measuring devices! Frost: see below. Soiling: replace the blocked filtrate hose.

Fault	Possible cause	Tests and / or corrective measures
Frost problems	Housing and filtrate line heater failure	<p>Problems with the housing and filtrate line heater are evident when the filtrate hoses in the control box are frozen. A timer failure is also possible. This is how to check the housing heater:</p> <ul style="list-style-type: none"> - 24 V AC between terminals 1 and 2? No: Check fuse 4 and replace if necessary? Voltage now present? No: transformer or cable connection defective. Contact service team! - Remove the micro thermostat between terminals 3 and 4 (24 V, safe). Connect terminals 3 and 4 with a piece of wire. Housing heater switches on and is warm after approx. 1 min? The same with the heater cable in the filtrate line to the filter elements? No: 230 V between terminals 10 and 16? If not, the relay circuit on the terminal board is defective. Contact service team! Yes: Heating element defective, contact service team! - The checks mentioned above are o.k. and still no housing heating? Micro thermostat defective, replace.
	Failure in sample line heater to the measuring devices	<p>Problems with the sample line heater to the measuring devices are evident when the sample is not transported on from the control box to the measuring devices and all other causes mentioned above have been ruled out.</p> <ul style="list-style-type: none"> - Check that the entire part of the sample line in danger of frosting over is heated by the electric band heater. Otherwise, a longer or an additional electric band heater must be used. - Check that the electric band heater has been connected correctly. - Is the orange thermal switch correctly attached to the pipe socket (see "Installation instructions" →  11)? Otherwise, the electric band heater heats up the thermal switch, which then does not switch properly. If the electric band heater is externally connected, the thermal switch must be in the open. - All of the checks mentioned above are o.k. and the hose is still frozen? Thermal switch defective, replace electric band heater.

9.2 Spare parts

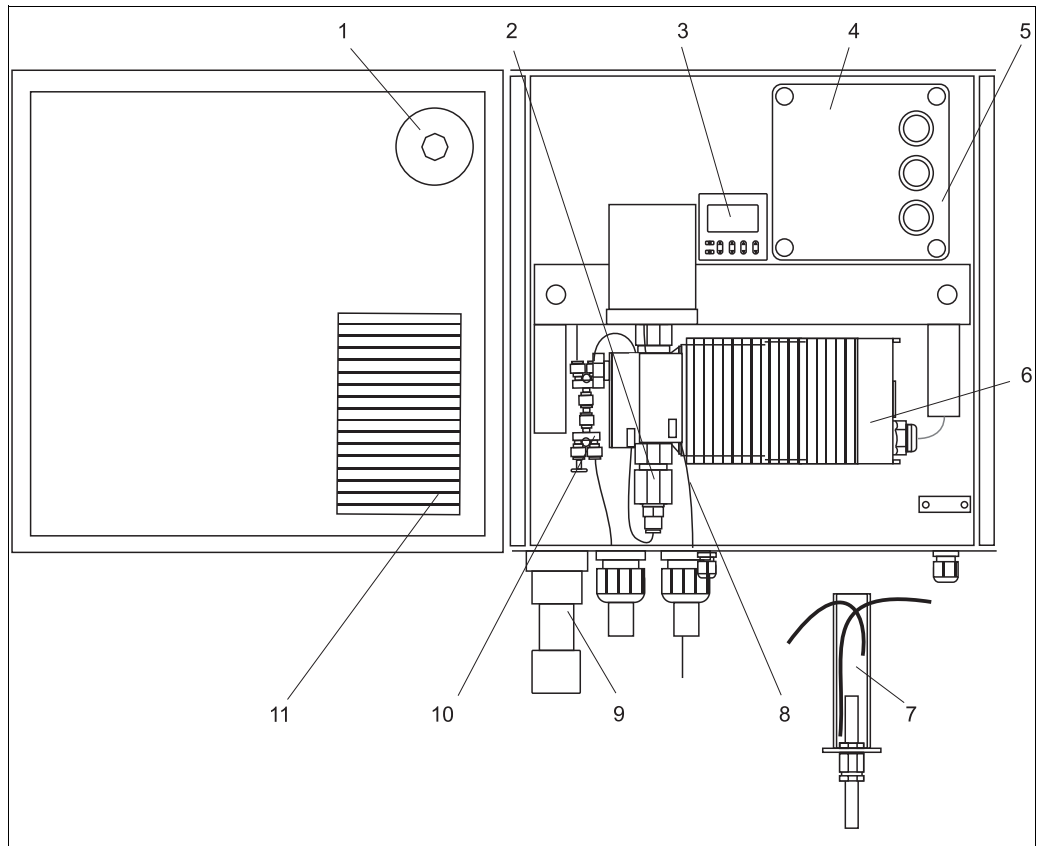

Fig. 35: Control box CAT430 and collecting vessel of CA7X

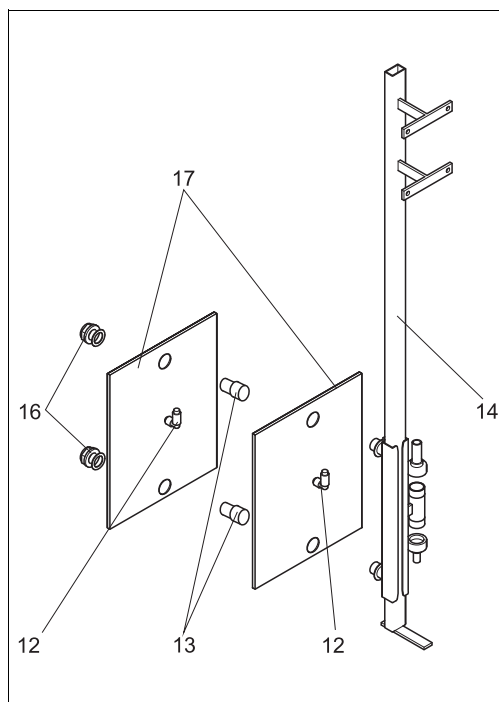

Fig. 36: Filter element holder for basin

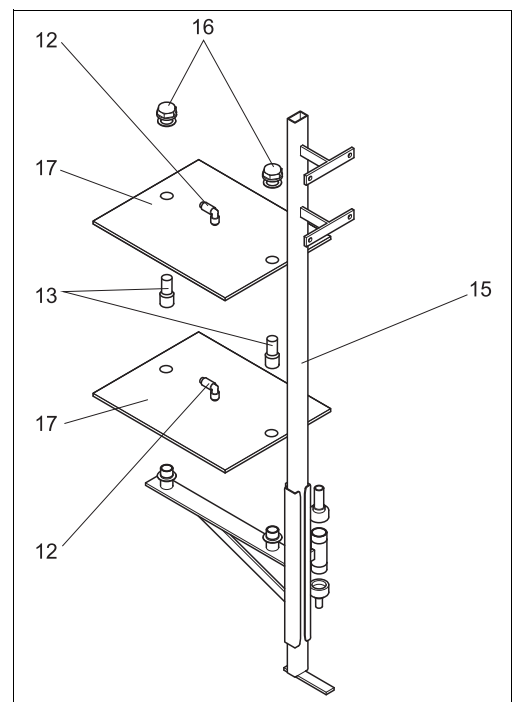

Fig. 37: Filter element holder for open channel



Note!

Please, find the ordering information to the spare parts from the following table.

Item	Spare part	Order code
1	Manometer with connector	51509228
2	Screw connection for Beta membrane pump	71093349
Not in figure	CAT430 pressure valve for Beta membrane pump	71038839
	Suction valve for Beta membrane pump	71038846
	CAT430 pump membrane for Beta membrane pump	71038847
	CAT430 safety membrane for Beta membrane pump	71038848
3	CAT430 conversion kit for electrical relay	71140521
4	Connection box with terminal board 230 V AC and transformer, without cover	51514294
	Connection box with terminal board 115 V AC and transformer, without cover	51518026
	Terminal board 230 V AC	51509231
	Terminal board 115 V AC	71089481
5	Connection box cover incl. switch	51509230
6	Complete CAT 430 Beta membrane pump	71003245
7	Collecting vessel for CAT430	51509238
8	CAT430 PVC hose, transparent, 4/2 mm (0.16/0.8 inch), length 2 m (6.6 ft)	51514284
9	Thermal switch for CAT430	51509232
10	CAT430 kit: pneumatic connector for membrane pump	71064561
11	Cabinet heater for CAT430, 110 to 230 V AC	51509233
Not in figure	Filtrate line with electric band heater, length 4.5 m (15 ft)	51509234
12	CAT430 filter element plug connector	51514278
13	G1 CAT430 adapter for fixing a second filter element	51511355
14	Filter element holder with vertical retaining slide for basin <ul style="list-style-type: none"> ■ length: 1.50 m (4.9 ft) ■ length: 1.80 m (5.9 ft) 	51511353 51511354
15	Filter element holder with horizontal retaining slide for open channel <ul style="list-style-type: none"> ■ length: 1.50 m (4.9 ft) ■ length: 1.80 m (5.9 ft) 	51511373 51511374
16	Securing nut for filter element for CAT430	51509237
17	Filter element for CAT430, with hose connector	51509236
Not in figure	Retaining rope for CAT430, PA 8 mm (0.32")	51509227
	Transportation/storage box for filter element CAT430	51512477
	CAT430 PE hose 4/2 mm (0.16/0.8 inch), length 25 m (82 ft)	51514281
	CAT430 PE hose 4/2 mm (0.16/0.8 inch), length 50 m (164 ft)	51514282
	CAT430 PE hose 4/2 mm (0.16/0.8 inch), length 100 m (328 ft)	51514283
	Filtrate hose from CAT430 to analyzer, 20 m (66 ft), spiral hose with: <ul style="list-style-type: none"> ■ 1 filtrate hose PE 4/2 (0.16/0.8 inch) ■ 18 m (59 ft) electric band heater 230 V 	51514285
	Set connectors <ul style="list-style-type: none"> ■ Y-piece ■ T-piece ■ Fitting ■ Blind plug 	51514276

9.3 Return

If the device requires repair, please send it *cleaned* to the sales center responsible.
Please use the original packaging, if possible.

Please enclose the completed "Declaration of contamination" (copy the second last page of these Operating Instructions) with the packaging and the transportation documents. No repair without completed "Declaration of contamination"!

9.4 Disposal

The device contains electronic components and must therefore be disposed of in accordance with regulations on the disposal of electronic waste.
Observe local regulations.

10 Technical data

10.1 Power supply

Control box connection	230 V AC, 50/60 Hz, 500 VA with 18m electric band heater connected, to be protected by the customer with 30 mA error current protective switch A suitable circuit breaker must be integrated by the customer directly upstream from the device supply cable.
-------------------------------	---

Analyzer compartment	For electric band heater > 20 m (66 ft): 15 VA per meter (4.5 VA per ft) electric band heater, socket 230 V AC, 50/60 Hz, to be protected by the customer with 30 mA error current protective switch
-----------------------------	---

10.2 Performance characteristics

Filtrate volume	approx. 250 ml/h (0.07 gal/hr) per filter element
------------------------	---

Sample transportation distance	max. 100 m (330 ft)
---------------------------------------	---------------------

Separation capacity	Separation of particles, colloids and bacteria (>0.1 µm)
----------------------------	--

Filter element operating life	approx. 1 to 2 years
--------------------------------------	----------------------

Cleaning interval	Filter element:	2 to 6 months, depending on contamination level
	Sample line:	
	PTFE hose	3 months
	PE hose	6 weeks

Chemical resistance	pH 1.5 to 12
----------------------------	--------------

Noise emission	< 70 dB
-----------------------	---------

10.3 Environment

Ambient temperature	-20 to 40 °C (-4 to 100 °F)
----------------------------	-----------------------------

Humidity	0 to 95 %, no splash water
-----------------	----------------------------

Ingress protection	IP 54
---------------------------	-------

Altitude above sea level	max. 2000 m (6500 ft)
---------------------------------	-----------------------

10.4 Process

Sample temperature 5 to 40 °C (40 to 100 °F)

10.5 Mechanical construction

Dimensions see chapter 3

Weight	Control box with membrane pump	15 kg (33 lbs)
	Housing CAT430-A1A*A4A	16 kg (35 lbs)
	Filter element	1 kg (2.2 lbs)
	Filter element holder	18 kg (40 lbs)

Materials	Control box housing	Glass-fibre reinforced polyester, self-quenching acc. to ASTM D 635 resp. UL 94-VO
	Filter element	PVC carrier plate, PAN membrane ¹⁾
	Filter element holder	Stainless steel, 1.4301 (AISI 304)

1) PAN = poly acrylic nitrile

Index

A

Accessories	39
Ambient temperature	46

C

capacity	21
Check	
Function	24
Post-connection	19
Post-installation	15
Chemical resistance	46
Cleaning	
Filter element	28
Sample hose	30
Cleaning interval	46
Commissioning	4, 24
Connecting the optional hose trace heating system	18
Connection	
Analyzer compartment	46
Control box	46
Control box	
Installation	12
Cycle times	21

D

Delay time	26
Designated use	4
Dimensions	47
Display	20

E

Electrical connection	16
Electrical technician	16
Environment	46
Errors	41

F

Fault	41
Filter element	
Accessories	40
Storage	29
Filter element holders	9, 39
Filter storage	29
Filtrate volume	46
Fuses	32

H

Humidity	46
----------------	----

I

Incoming acceptance	8
Ingress protection	46
Installation	4, 8, 13
Control box	12
Filter element	11
Filter element holders	9
Sample lines	13
Installation instructions	9

L

Life cycle	46
Local operation	21

M

Maintenance	28
Materials	47
Measuring system	8
Mechanical construction	47
Micro thermostat	14, 42

N

Nameplate	6
Notes on safety conventions and icons	5

O

Operating mode	23
Operation	4, 20
Operational safety	4
Ordering information	6

P

Performance characteristics	46
Post-connection check	19
Post-installation	15
Power supply	17, 46
Pressure valve	34
Process	47
Product structure	6
Pump	
capacity	21
Changing the membrane	36
Cycle times	21
Tighten fixing screws	35
Pump switch-on and switch-off times	22

R

Repairs	31
Replacing	
Check valves	33
Device fuses	32
Filter element	31
Filtrate hose	30
Pump hose	29
Timer	32
Return	4, 45

S

Sample temperature 47
Scope of delivery 7
Separation capacity 46
Settings 21
Spare parts 43
Storage 8
Suction valve 34
Switch-on 24

T

Technical data 46–47
Time range 23
Timer 20, 22
 Replacing 32
Transport 8
transportation distance 46

U

Use 4

V

Valves
 Cleaning 33
 Pressure valve 34
 Suction valve 34

W

Weight 47
Wiring diagram 16

Declaration of Hazardous Material and De-Contamination

Erklärung zur Kontamination und Reinigung

RA No.

Please reference the Return Authorization Number (RA#), obtained from Endress+Hauser, on all paperwork and mark the RA# clearly on the outside of the box. If this procedure is not followed, it may result in the refusal of the package at our facility.
Bitte geben Sie die von E+H mitgeteilte Rücklieferungsnummer (RA#) auf allen Lieferpapieren an und vermerken Sie diese auch außen auf der Verpackung. Nichtbeachtung dieser Anweisung führt zur Ablehnung ihrer Lieferung.

Because of legal regulations and for the safety of our employees and operating equipment, we need the "Declaration of Hazardous Material and De-Contamination", with your signature, before your order can be handled. Please make absolutely sure to attach it to the outside of the packaging.

Aufgrund der gesetzlichen Vorschriften und zum Schutz unserer Mitarbeiter und Betriebseinrichtungen, benötigen wir die unterschriebene "Erklärung zur Kontamination und Reinigung", bevor Ihr Auftrag bearbeitet werden kann. Bringen Sie diese unbedingt außen an der Verpackung an.

Type of instrument / sensor Serial number
Geräte-/Sensortyp Seriennummer

Used as SIL device in a Safety Instrumented System / Einsatz als SIL Gerät in Schutzeinrichtungen

Process data/ Prozessdaten Temperature / Temperatur [°F] [°C] Pressure / Druck [psi] [Pa]
Conductivity / Leitfähigkeit [µS/cm] Viscosity / Viskosität [cp] [mm²/s]

Medium and warnings
Warnhinweise zum Medium



	Medium /concentration Medium /Konzentration	Identification CAS No.	flammable entzündlich	toxic giftig	corrosive ätzend	harmful/ irritant gesundheitsschädlich/ reizend	other * sonstiges*	harmless unbedenklich
Process medium Medium im Prozess								
Medium for process cleaning Medium zur Prozessreinigung								
Returned part cleaned with Medium zur Endreinigung								

* explosive; oxidising; dangerous for the environment; biological risk; radioactive

* explosiv; brandfördernd; umweltgefährlich; biogefährlich; radioaktiv

Please tick should one of the above be applicable, include safety data sheet and, if necessary, special handling instructions.

Zutreffendes ankreuzen; trifft einer der Warnhinweise zu, Sicherheitsdatenblatt und ggf. spezielle Handhabungsvorschriften beilegen.

Description of failure / Fehlerbeschreibung

Company data / Angaben zum Absender

Company / Firma <input type="text"/>	Phone number of contact person / Telefon-Nr. Ansprechpartner: <input type="text"/>
Address / Adresse <input type="text"/>	Fax / E-Mail <input type="text"/>
<input type="text"/>	Your order No. / Ihre Auftragsnr. <input type="text"/>

"We hereby certify that this declaration is filled out truthfully and completely to the best of our knowledge. We further certify that the returned parts have been carefully cleaned. To the best of our knowledge they are free of any residues in dangerous quantities."

"Wir bestätigen, die vorliegende Erklärung nach unserem besten Wissen wahrheitsgetreu und vollständig ausgefüllt zu haben. Wir bestätigen weiter, dass die zurückgesandten Teile sorgfältig gereinigt wurden und nach unserem besten Wissen frei von Rückständen in gefahrbringender Menge sind."

www.endress.com/worldwide

Endress+Hauser 
People for Process Automation
