



Level



Pressure



Flow



Temperature



Liquid  
Analysis



Registration



Systems  
Components



Services



Solutions

## Operating Instructions

# CCS120

Sensor for total chlorine

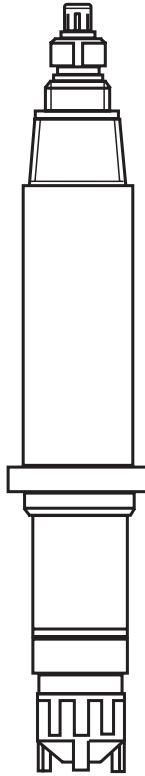

BA388C/07/en/07.06  
51517372

# Brief overview

Here is how to use these Operating Instructions to commission your sensor quickly and safely:

→ Page 4 ff. → Page 5	<b>Safety instructions</b> General safety instructions Explanation of the warning symbols
	▼
→ Page 7 → Page 8 ff.	<b>Installation</b> Here you can find installation conditions such as sensor dimensions. Installation examples can be found here.
	▼
→ Page 11 ff.	<b>Wiring</b> Refer to these pages for sensor wiring.
	▼
→ Page 14 ff.	<b>Operating</b> This chapter describes how to fill in the electrolyte.
	▼
→ Page 16 ff.	<b>Commissioning</b> Here you find how to calibrate the sensor.
	▼
→ Page 18 → Page 19 ff.	<b>Maintenance</b> It is absolutely essential to carry out maintenance tasks on a regular basis. An overview of the available spare parts and accessories.
	▼
→ Page 20 ff.	<b>Trouble shooting</b> If faults occur during operation, use the checklist to locate the cause.
	▼
→ Page 25 ff.	<b>Index</b> You can find important terms and keywords on the individual sections here. Use the keyword index to find the information you need quickly and efficiently.

## Table of contents

<b>1</b>	<b>Safety instructions</b> . . . . .	<b>4</b>	<b>9</b>	<b>Troubleshooting</b> . . . . .	<b>20</b>
1.1	Designated use . . . . .	4	9.1	Troubleshooting instructions . . . . .	20
1.2	Installation, commissioning and operation . . . . .	4	9.2	Return . . . . .	22
1.3	Operational safety . . . . .	5	9.3	Disposal . . . . .	22
1.4	Return . . . . .	5			
1.5	Notes on safety icons and symbols . . . . .	5	<b>10</b>	<b>Technical data</b> . . . . .	<b>23</b>
<b>2</b>	<b>Identification</b> . . . . .	<b>6</b>	10.1	Input . . . . .	23
2.1	Product structure . . . . .	6	10.2	Output . . . . .	23
2.2	Scope of delivery . . . . .	6	10.3	Performance characteristics . . . . .	23
<b>3</b>	<b>Installation</b> . . . . .	<b>6</b>	10.4	Power supply . . . . .	24
3.1	Incoming acceptance, transport, storage . . . . .	6	10.5	Environment . . . . .	24
3.2	Installation conditions . . . . .	7	10.6	Mechanical construction . . . . .	24
3.3	Installation instructions . . . . .	8			
3.4	Post-installation check . . . . .	10			
<b>4</b>	<b>Wiring</b> . . . . .	<b>11</b>			
4.1	Direct connection to the transmitter . . . . .	11			
4.2	Connection via junction box . . . . .	12			
4.3	Post-connection check . . . . .	12			
<b>5</b>	<b>Operation</b> . . . . .	<b>13</b>			
5.1	Sensor design . . . . .	13			
5.2	Measuring principle . . . . .	13			
5.3	Electrolyte fill in . . . . .	14			
<b>6</b>	<b>Commissioning</b> . . . . .	<b>16</b>			
6.1	Function check . . . . .	16			
6.2	Polarisation . . . . .	16			
6.3	Calibration . . . . .	16			
<b>7</b>	<b>Maintenance</b> . . . . .	<b>18</b>			
<b>8</b>	<b>Accessories</b> . . . . .	<b>19</b>			
8.1	Connection accessories . . . . .	19			
8.2	Installation accessories . . . . .	19			
8.3	Transmitter . . . . .	19			
8.4	Maintenance/calibration . . . . .	20			
				<b>Index</b> . . . . .	<b>25</b>

# 1 Safety instructions

## 1.1 Designated use

The sensor is used for continuous measurement of total chlorine in water. Within this context the following compounds are included in the term total chlorine:

- free chlorine ( $\text{Cl}_2$  (dissolved),  $\text{HOCl}$ ,  $\text{OCl}^-$ )
- bound chlorine (chloramines)
- organic-bound chlorine (e.g. cyanuric acid derivatives)

Typical applications are:

- Controlling total chlorine content of drinking, industrial, process, cooling water and pool sector
- Measuring total chlorine content in fresh water and sea water for process, swimming pool and whirl pool treatment

Any other use than the one described here compromises the safety of persons and the entire measuring system and is, therefore, not permitted.

The manufacturer is not liable for damage caused by improper or non-designated use.

## 1.2 Installation, commissioning and operation

Please note the following items:

- Installation, commissioning, operation and maintenance of the measuring system must only be carried out by trained technical personnel.  
The technical personnel must be authorized for the specified activities by the system operator.
- Electrical connection must only be carried out by a certified electrician.
- Technical personnel must have read and understood these Operating Instructions and must adhere to them.
- Before commissioning the entire measuring point, check all the connections for correctness. Ensure that electrical cables and hose connections are not damaged.
- Do not operate damaged products and secure them against unintentional commissioning. Mark the damaged product as being defective.
- Measuring point faults may only be rectified by authorized and specially trained personnel.
- If faults can not be rectified, the products must be taken out of service and secured against unintentional commissioning.
- Repairs not described in these Operating Instructions may only be carried out at the manufacturer's or by the service organisation.

### 1.3 Operational safety

The sensor has been designed and tested according to the state of the art and left the factory in perfect functioning order.

Relevant regulations and European standards have been met.

As the user, you are responsible for complying with the following safety conditions:

- Installation instructions
- Local prevailing standards and regulations.

### 1.4 Return

If the sensor has to be repaired, please return it *cleaned* to the sales centre responsible. Please use the original packaging, if possible.

Please enclose the completed "Declaration of Hazardous Material and De-Contamination" (copy the second last page of these Operating Instructions) with the packaging and the transportation documents.

**No repair without completed declaration!**

### 1.5 Notes on safety icons and symbols

Warning!



This symbol alerts you to hazards. They can cause serious damage to the instrument or to persons if ignored.

Caution!



This symbol alerts you to possible faults which could arise from incorrect operation. They could cause damage to the instrument if ignored.

Note!



This symbol indicates important items of information.

## 2 Identification

### 2.1 Product structure

		<b>Mesuring range</b>	
A		0.1 ... 10	mg/l
		<b>Head type</b>	
S		Thread NPT 3/4"; plug TOP 68	
		<b>Options</b>	
0		none	
CCS120-			complete order code

### 2.2 Scope of delivery

The following items are included in the delivery:

- 1 sensor CCS120
- 1 bottle containing electrolyte (50 ml) and nozzle
- 1 membrane cap for replacement
- 1 operating instructions BA 388C/07/en

## 3 Installation

### 3.1 Incoming acceptance, transport, storage

- Make sure the packaging is undamaged!  
Inform the supplier about damage to the packaging. Keep the damaged packaging until the matter has been settled.
- Make sure the contents are undamaged!  
Inform the supplier about damage to the delivery contents. Keep the damaged products until the matter has been settled.
- Check that the scope of delivery is complete and agrees with your order and the shipping documents.
- The packaging material used to store or to transport the product must provide shock protection and humidity protection. The original packaging offers the best protection. Also, keep to the approved ambient conditions (see "Technical data").
- If you have any questions, please contact your supplier or your sales center responsible.

## 3.2 Installation conditions

### 3.2.1 Dimensions

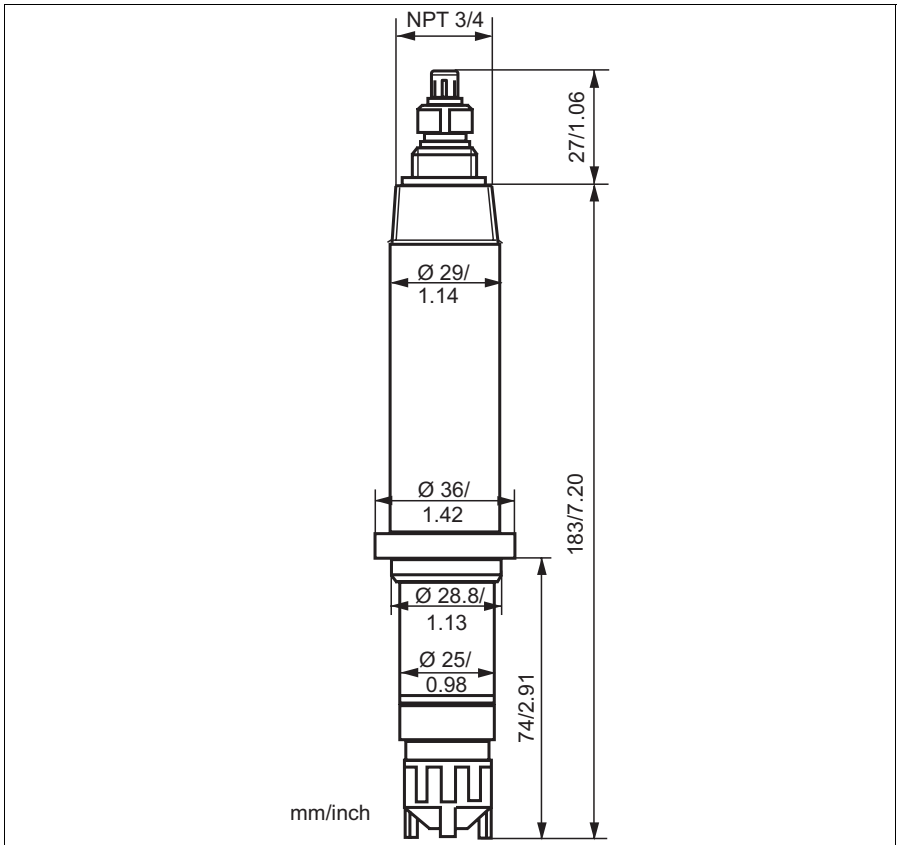

Fig. 1: Dimensions

a0003082

### 3.3 Installation instructions

#### 3.3.1 Measuring system

A complete measuring system in the flow mode comprises at least:

- Chlorine sensor
- Transmitter Liquisys M CCM223/253
- Special measuring cable
- Flow assembly

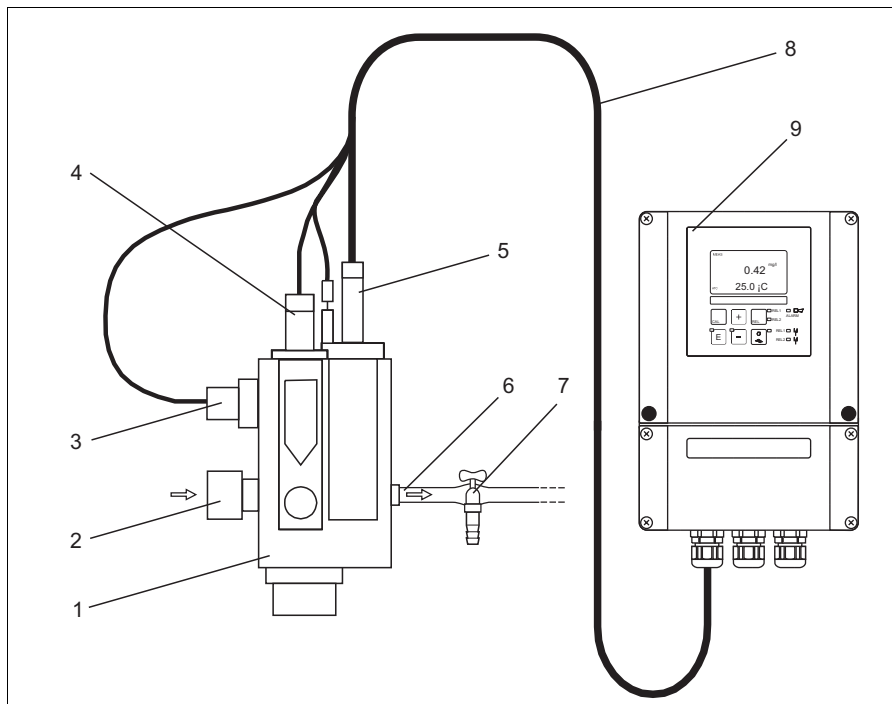

Fig. 2: Measuring system in the flow mode (example)

a0001691

- |   |  |   |                            |
|---|--|---|----------------------------|
| 1 | Flow assembly CCA250                           | 6 | Medium outlet              |
| 2 | Medium inlet                                   | 7 | Sampling tap               |
| 3 | Inductive proximity switch for flow monitoring | 8 | Measuring cable CPK9-N*A1B |
| 4 | Mounting place for pH/redox sensor             | 9 | Transmitter                |
| 5 | Chlorine sensor CCS120                         |   |                            |

The measuring system described above is available as CCE-system (fully mounted on a board).



A complete measuring system in the immersion mode comprises at least:

- Chlorine sensor
- Transmitter Liquisys M CCM223/253
- Special measuring cable
- Immersion assembly

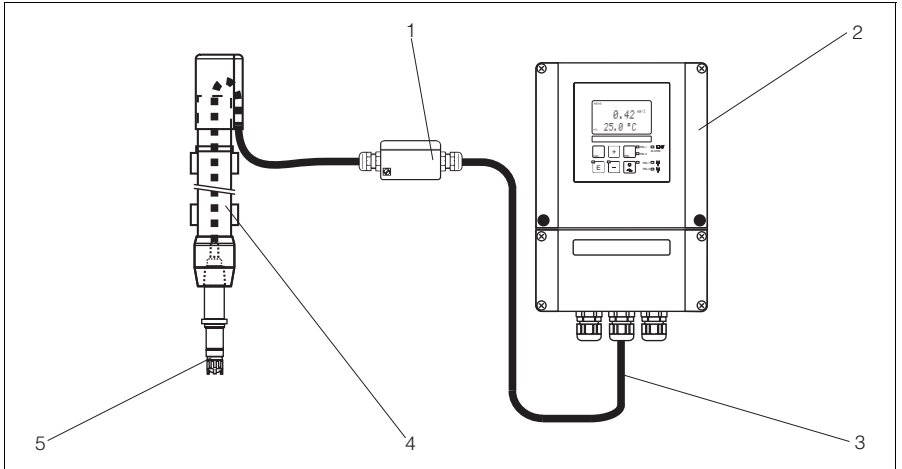

Fig. 3: Measuring system in the immersion mode (example)

a0003087

1	Function box VBM	4	Immersion assembly CYA611-0B
2	Transmitter	5	Chlorine sensor CCS120
3	Measuring cable CYK71		

### 3.3.2 Installing the sensor in flow assembly CCA250

The flow assembly CCA250 is designed for on-site installation of the sensor. In addition to the chlorine sensor, a pH and redox sensor can be installed. A needle valve regulates the flow within the range of 30 ... 100 l/h (7.92 ... 26.40 US.gal/h). If the value drops below 30 l/h (7.92 US.gal/h) or flow stops completely, this can be detected by an inductive proximity switch and an alarm signal plus locking of the dosage pumps can be triggered.

Note the instructions and safety guidelines in the operating instructions of the flow assembly. If the medium is fed back into a surge tank, pipeline or the like, ensure that the thus generated back pressure on the sensor does not exceed 1 bar (14.5 psi) and remains constant. Negative pressure at the sensor, e.g. by feedback of medium to the suction side of a pump, must be avoided.

### **3.3.3 Installing the sensor in immersion assembly CYA611**

The immersion assembly CYA611-0B is designed for on-site installation of the sensor. Cover the thread NPT 3/4" with a layer of Teflon tape. Screw the sensor into the assembly. Note the instructions and safety guidelines in the operating instructions of the immersion assembly.

### **3.4 Post-installation check**

- Check the membrane for leak tightness und replace it if necessary.
- Is the sensor installed in an assembly and is not suspended from the cable?

## 4 Wiring



Warning!

- The electrical connection must only be carried out by a certified electrician.
- Technical personnel must have read and understood the instructions in this manual and must adhere to them.
- Ensure that there is no voltage at the power cable before beginning the connection work.

### 4.1 Direct connection to the transmitter

Use the measuring cable CPK9-N\*A1B (internal PM wire) to connect the sensor according to the following connection table. See also the notes in the operating instructions of the transmitter.

Cable with TOP68 coupling			Liquisys
Pin	Assignment	Core	Terminal
1	TC-signal	coax-inner (white)	90
2	AGND	coax-outer (black)	12
3			
4	+UB (15 V)	green	85
5	NTC1	yellow*	11
	NTC1	white*	11
6	NTC2/AGND	brown	86
S	screen	S	S

\* The white and the yellow cores are connected inside of the TOP68 coupling.

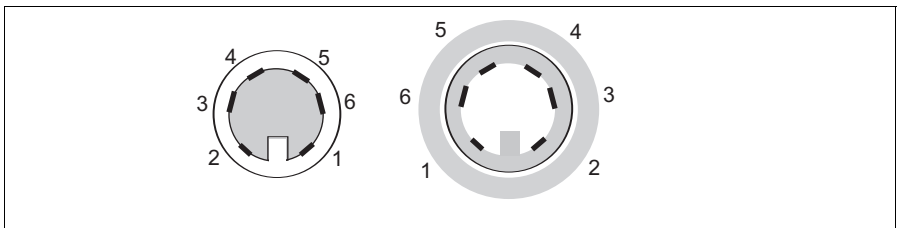
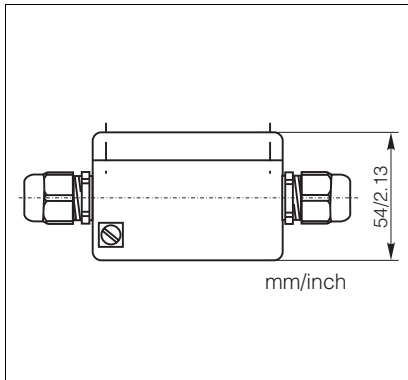

Fig. 4: TOP68 plug pin arrangement (view from contact side)

a0001689

## 4.2 Connection via junction box

To lengthen the sensor connection you require the junction box VBM (Fig. 5, Fig. 6) . The connection is lengthened to the transmitter using the special measuring cable CYK71.



C07-COS41xxx-04-05-00-en-003.eps

Fig. 5: Junction box VBM, side view

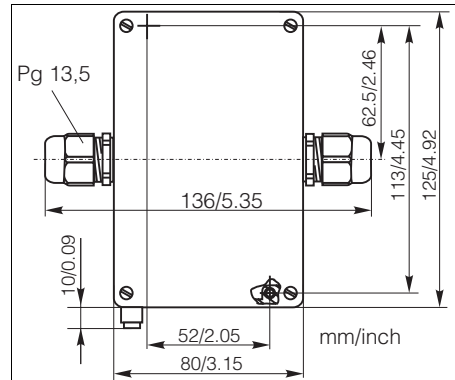

C07-COS41xxx-04-05-00-en-004.eps

Fig. 6: Junction box VBM, top view

## 4.3 Post-connection check

Instrument status and specifications	Remarks
Are the sensor, assembly, junction box or cable damaged?	Visual inspection
Electrical connection	Remarks
Does the supply voltage of the transmitter match the specifications on the nameplate?	110/230 V AC 24 V AC/DC
Are the installed cables strain-relieved and not twisted?	
Is the cable type route completely isolated?	Power cable/weak current cable
Are the power supply and signal cable correctly connected to the transmitter?	Use the connection diagram of CCM2x3.
Are all the screws terminals properly tightened?	
Are all the cable entries installed, tightened and sealed?	For lateral cable entries : cable loops downwards for water to be able to drip off.
Are all the cable entries installed downwards or lateral?	

## 5 Operation

### 5.1 Sensor design

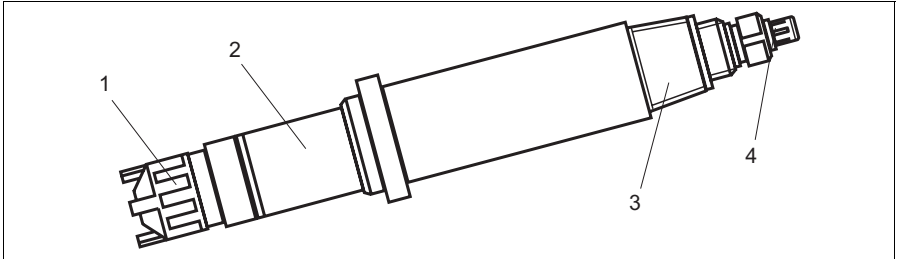

Fig. 7: Sensor design

a0006354

1	Membrane cap	3	Thread NPT 3/4"
2	Sensor shaft	4	TOP68 plug

### 5.2 Measuring principle

The amperometric sensor is based on the conversion of the measuring variable chlorine in electrical current. Two electrodes covered by an electrolyte are in contact to the medium via a membrane. It has a platinum working electrode and a silver halogenide coated counter or reference electrode. The chlorine compounds contained in the medium diffuse through the membrane. The constant polarisation voltage between the two electrodes instigates the electrochemical reaction of the chlorine compounds on the working electrode. The resulting current is measured as a primary signal (amperometric measurement principle). It is proportional to the chlorine concentration within the sensor's operating range and only slightly pH dependant for this type of sensor. The primary signal is converted by the amplifier electronics of the sensor into a 0 ... 5  $\mu$ A output signal which is displayed by the transmitter.

### 5.3 Electrolyte fill in



#### Warning!

Do not swallow the electrolyte. Avoid contact of the electrolyte with skin and eyes. Otherwise wash with a lot of water. In case of eye inflammation, contact a doctor.



#### Caution!

- Do not touch or damage the membrane or electrodes.
- The electrolyte is sensitive to oxidation: always keep the electrolyte bottle closed after use. Do not transfer the electrolyte into other containers.
- The electrolyte should not be stored for more than 1 year and should not yellow (use by date, see label).
- Avoid forming air bubbles as far as possible when pouring the electrolyte into the membrane cap.
- The membrane cap must be used once only.



#### Note!

- Store the electrolyte bottle upside down in order that the viscous electrolyte can be poured easily and bubble free into the membrane cap.
- Smaller bubbles will not interfere, larger bubbles leave the electrolyte by rising to the surface.

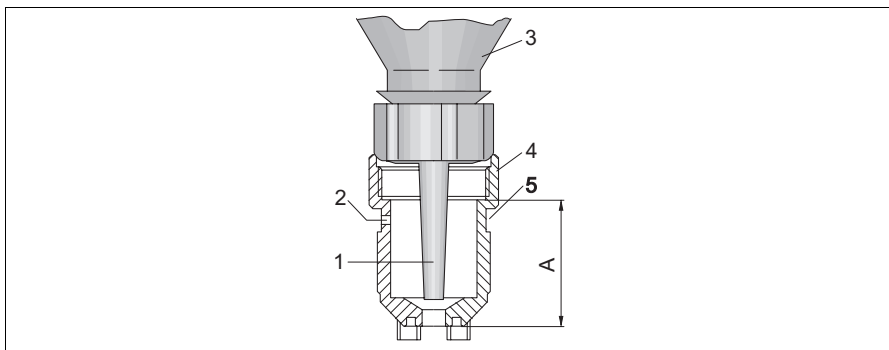

Fig. 8: Membrane cap with electrolyte bottle

a0001688

1	Nozzle	4	Membrane cap
2	Vent hole	5	Rubber seal
3	Electrolyte bottle	A	Electrolyte filling level

Perform the following steps to fill the membrane cap with electrolyte:

1. Open the electrolyte bottle and screw on the nozzle.
2. Squeeze out excess air.
3. Place the electrolyte bottle completely onto the membrane cap (Fig. 8).
4. Slowly squeeze the electrolyte out of the bottle in one steady stream, while continuously retracting the bottle. The cap is completely full when the electrolyte reaches the lower edge of the thread.

Now you have to install the membrane cap:

1. Place the sensor shaft vertically onto the filled membrane cap.
2. Do not cover the vent hole below the rubber seal with your fingers.
3. Tighten on the membrane cap by hand as far as possible. There should not be a visible gap between the sensor shaft and membrane cap. When you screw on the cap, excess electrolyte will leak out through the hole below the rubber seal.
4. Wipe away any electrolyte with a soft paper tissue or similar.
5. Rinse the nozzle thoroughly with a clean, warm water jet so that no electrolyte remains on the inside and outside of the nozzle.

## 6 Commissioning



Note!

- Read also the instructions for operation and commissioning in the operating instructions of the transmitter.
- The power supply to the transmitter and to the sensor must not be interrupted. If the power supply is interrupted (> 2 hours) the sensor must be re-commissioned (polarisation time).
- Do not switch off the measuring device during intermittent operation. Dosing devices may be controlled by timer switches.  
However, if no disinfectant is metered over a longer period of time (weeks), the sensor must be disconnected from the system and stored dry.
- Once the sensor has been commissioned it must be kept permanently wet.

### 6.1 Function check

Before first commissioning, check if:

- the sensor is correctly installed
- the electrical connection is correct.

### 6.2 Polarisation

The voltage applied between cathode and anode by the transmitter polarises the surface of the working electrode. Therefore, after switching on the transmitter with connected sensor, you have to wait until the polarisation period has elapsed before you can start a calibration.

In order to achieve a stable display value the sensor needs the following polarisation period:

First commissioning:	24 h
After changing membrane:	1 – 6 h
Re-commissioning:	approx. 4 – 24 h

### 6.3 Calibration

#### Reference measurement according to the DPD method

The calibration of the measuring system requires a colorimetric reference measurement according to the DPD method. Chlorine reacts with diethyl-p-phenylenediamine (DPD) by producing a red dye, the intensity of the red colour being proportional to the chlorine concentration.

The intensity of the red dye is measured by a photometer (e.g. CCM182, see accessories) and displayed as chlorine concentration.



## Requirements

The sensor reading is stable (no drifts or unsteady values for at least 5 minutes). This is normally fulfilled, when:

- The polarisation period is finished.
- The flow is constant and within the correct range.
- The sample medium and the sensor are at the same temperature.
- The pH value is within the admissible range.

## Zero point calibration

Zero point calibration is only necessary when the sensor is used at the lower limit of the measuring range.

For zero point calibration, perform the following steps:

1. Remove the sensor from the assembly (see operating instructions of the assembly).
2. Clean the sensor thoroughly. The sensor must be totally free of chlorine for the next working step.
3. Stir the sensor in a container filled with clean water (free of chlorine and bromine) until the measured value remains stable.
4. Adjust the transmitter to zero according to its operating instructions.
5. Reinstall the sensor into the assembly (see operating instructions of the assembly).

## Slope calibration

For slope calibration, perform the following steps:

1. Insert the sensor into the assembly, if not already done (see operating instructions of the assembly).
2. Take a sample for DPD measurement. Sampling location has to be close to the installed sensor. Use the sampling tap in the case of the compact chlorine system CCE1.
3. Determine the total chlorine content with a photometer (e.g. CCM182, see accessories) according to the DPD 1 / DPD 3 method. See the operating instructions of the photometer. Alternatively you can use the DPD 4 method.
4. Enter the measured value into the transmitter (see operating instructions of the transmitter).
5. After initial installation of the sensor, check the calibration by DPD measurement 24 hours later.

The following calibration intervals are recommended:

- Drinking, industrial, process and cooling water: depending on the specific conditions (1 - 4 weeks)
- Swimming pools: weekly
- Whirlpools: daily



Note!

Carry out a slope calibration every time the membrane or electrolyte is changed.

## 7 Maintenance



Note!

- Service the sensor regularly to avoid incorrect dosing within a control system, due to incorrect measured value.
- Do not touch the electrodes or allow them to come into contact with greasy substances.
- Never attempt to clean the membrane with acid/alkaline solutions, cleaning reagents or mechanical aids (brushes or similar).

Maintenance intervals based on experience are:

- Drinking, industrial, process and cooling water: depending on the specific conditions (1-4 weeks)
- Swimming pools: weekly
- Whirlpools: daily

Perform the following maintenance work:

- Check the sensor for dirt, algae and air bubbles. If necessary clean the sensor with clear water and a soft tissue. Eliminate air bubbles by increasing the flow rate.
- Check the displayed sensor value on the transmitter according to the DPD 1 / DPD 3 method. Use a photometer (e.g. CCM182 , see accessories).
- If necessary, recalibrate the sensor.
- If calibration cannot be carried out properly, replace the membrane cap and repeat the calibration.

## 8 Accessories

### 8.1 Connection accessories

Junction box VBM

- For cable extension, with 10 terminals
- IP 65 / NEMA 4X
- Material: aluminum
- Order numbers:
  - cable entry Pg 13.5: 50003987
  - cable entry NPT ½": 51500177
- Measuring cable CCS120-1M, cable length: 1 m (3.28 ft), for compact chlorine system CCE1 order no. 51517204
- Special measuring cable CPK9-N\*A1B internal PM wire  
For sensors with TOP68 plug-in head, for high-temperature and high-pressure applications, IP 68  
Ordering acc. to product structure, see Technical Information (TI118C/07/en)

### 8.2 Installation accessories

- Flow assembly CCA250  
for chlorine, chlorine dioxide, pH and redox;  
Ordering acc. to product structure, see Technical Information (TI062C/07/en)
- Immersion assembly Dipfit W CYA611-0B  
for sensor immersion in basins, open channels and tanks, PVC;  
Ordering acc. to product structure (Technical Information TI166C/07/en)
- Compact chlorine system CCE1  
Factory-assembled and wired panel for transmitter with flow assembly CCA250-A1; see also Technical Information TI014C/07/en

### 8.3 Transmitter

- Liquisys M CCM223/253  
Transmitter for chlorine, field or panel-mounted housing,  
Hart® or PROFIBUS available,  
Ordering acc. to product structure, see Technical Information (TI214C/07/en)

## 8.4 Maintenance/calibration

- Photometer CCM182; microprocessor-controlled photometer for chlorine, pH value, cyanuric acid;  
Chlorine measuring range: 0.05 to 6 mg/l  
pH measuring range: 6.5 to 8.4
- Electrolyte for CCS120, 50 ml  
order no. 51516343
- Service kit for CCS120, consists of 2 membrane caps and 1 bottle of electrolyte (50 ml)  
order no. 51517284

## 9 Troubleshooting

### 9.1 Troubleshooting instructions

Troubleshooting must take account of the whole measuring system. The measuring system consists of:

- Transmitter
- Electrical leads and connectors
- Assembly
- Sensor

The possible causes of failure listed in the following table primarily refer to the total chlorine sensor. Before commencing troubleshooting, please ensure that the following operating conditions in "Technical data" are met:

- Chlorine content lies within the corresponding measurement range of the sensor (0.1 ... 10 mg/l)
- Constant pH in the range 5.5 - 9.5
- Constant temperature in the range 4 ... 45 °C (39 ... 113 °F)
- Conductivity: 0.03 ... 40 mS/cm
- Flow: 30 ... 100 l/h (7.92 ... 26.40 US.gal./h)

If the value measured by the sensor differs significantly from that of the DPD method you need to first consider all possible malfunctions of the DPD photometric method (see operating instructions of the photometer). If necessary, repeat the DPD measurement several times.

<b>Fault</b>	<b>Possible cause</b>	<b>Action</b>
Sensor cannot be calibrated. Measured value higher than DPD measurement	Polarisation time not finished	Wait until polarisation time is finished
	Membrane cap is damaged	Replace membrane cap; wait until polarisation time is finished, calibrate
	Interfering substances in medium	Examine medium for interfering substances and remedy
	Short circuit in signal cable	Locate and eliminate short circuit
	Distance between electrode and membrane is too large	Screw the membrane until the limit
	DPD chemicals are outdated	Use new DPD chemicals, repeat calibration
	pH value < pH 5.5	Raise pH value (pH 5.5 ... 9.5)
Sensor cannot be calibrated. Measured value lower than DPD measurement	Polarisation time not finished	Wait until polarisation time is finished
	Deposits on membrane cap	Replace membrane cap; wait until polarisation time is finished, calibrate
	Flow rate too low	Correct flow rate
	Air bubbles on the outside of the membrane	Increase the flow rate within the permitted range
	Interfering substances in medium (surfactants, oil, alcohols, corrosion inhibitors)	Contact sales center
	Value substantially exceeds measuring range	Replace membrane cap; wait until polarisation time is finished, calibrate
	Deposits (carbonate, manganese, iron oxide) have blocked membrane	Replace membrane cap; wait until polarisation time is finished, calibrate
	pH value > pH 9.5	Lower pH value (pH 5.5 ... 9.5)
Measured value of sensor is 0 mg/l	No electrolyte in membrane cap	Refill membrane cap with electrolyte
	Polarisation time not finished	Wait until polarisation time is finished
	Interfering substances which consume chlorine	Examine medium for interfering substances and remedy
	Zero point has shifted	Perform zero point calibration
	Reference electrode defective	Return sensor to sales center for regeneration

Fault	Possible cause	Action
Measured value of sensor is arbitrary and sensor current > 5 $\mu$ A	Chlorine concentration exceeds the upper limit of measuring range	Check the whole system, remedy fault and calibrate sensor
	Distance between electrode and membrane is too large	Screw the membrane until the limit
	Sensor defective	Return sensor to the sales center
Measured value of sensor is not stable	Pressure fluctuation in sampling line	Check installation position and change the process if necessary
	Reference electrode defective	Return sensor to the sales center

## 9.2 Return

If the sensor has to be repaired, please return it *cleaned* to the sales centre responsible. Please use the original packaging, if possible.

Please enclose the completed "Declaration of Hazardous Material and De-Contamination" (copy the second last page of these Operating Instructions) with the packaging and the transportation documents.

**No repair without completed declaration!**

## 9.3 Disposal

The device contains electronic components and must therefore be disposed of in accordance with regulations on the disposal of electronic waste.

Please observe local regulations.

## 10 Technical data

### 10.1 Input

<b>Measured variable</b>	Total chlorine	Free chlorine (Cl <sub>2</sub> (dissolved), HOCl, OCl <sup>-</sup> ) Bound chlorine (chloramines) Organic-bound chlorine (e.g. cyanuric acid derivatives)
<b>Applications</b>	Drinking, industrial, process, cooling water, fresh water and sea water for swimming pool and whirlpool treatment	
<b>Measuring range</b>	0.1 ... 10 mg/l	
<b>Slope</b>	110 ... 120 nA/(mg/l)	

### 10.2 Output

<b>Output signal</b>	0 ... 5 µA for the connection to the transmitter Liquisys M CCM223/253
----------------------	--

### 10.3 Performance characteristics

<b>Response time</b>	T <sub>90</sub> approx. 60 s (as concentration rises and falls)	
<b>Resolution</b>	0.01 mg/l	
<b>pH range</b>	5.5 ... 9.5 pH dependency: jump from pH 7 to pH 8: approx. -10 % for free chlorine	
<b>Conductivity range</b>	0.03 ... 40 mS/cm	
<b>Temperature range</b>	5 ... 45 °C (41 ... 113 °F), no quick changes in temperature allowed	
<b>Pressure</b>	Medium in the CCA250 assembly: max. 1 bar (14.5 psi)	
<b>Flow</b>	optimum:	40 ... 60 l/h (10.56 ... 15.84 US.gal/h)
	minimum:	30 l/h (7.92 US.gal/h)
	maximum:	100 l/h (26.40 US.gal/h)
<b>Medium velocity</b>	optimum:	20 ... 30 cm/s (0.7 ... 1.0 ft/s)
	minimum:	15 cm/s (0.5 ft/s)
	maximum:	50 cm/s (1.6 ft/s)
<b>Cross sensitivity</b>	Oxidising reagents e.g. bromine, iodine, ozone, chlorine dioxide, permanganates result in false positive results. Reducing reagents like sulphides, sulphites, tiosulphates, and hydrazine result in false negative results.	
<b>Service life of membrane cap</b>	Typically 3 - 6 months, depending on water quality	

## 10.4 Power supply

<b>Power supply</b>	15 V DC, 10 mA
---------------------	----------------

## 10.5 Environment

<b>Storage temperature</b>	Filled with electrolyte:	5 ... 50 °C (41 ... 122 °F)
	Without electrolyte:	-20 ... +60 °C (-4 ... +140 °F)
<b>Ingress protection</b>	IP 65	

## 10.6 Mechanical construction

<b>Design, dimensions</b>	see chapter "Installation"	
<b>Weight</b>	approx. 0.14 kg (0.3 lb)	
<b>Materials</b> (in contact with medium)	Sensor shaft Membrane cap	PVC PPE
<b>Cable length</b>	max. 15 m (49.22 ft)	
<b>Temperature compensation</b>	NTC temperature sensor 10 kΩ at 25 °C (77 °F)	



## Index

### A

Accessories	
Assemblies	19
Compact chlorine system	19
Connection accessories	19
Consumables	20
Photometer	20
Transmitter	19

### C

Cable length	24
Calibration	16
Checking	
Connection	12
Function	16
Commissioning	4, 16
Connection	
Checking	12
Direct connection	11
Via junction box	12

### D

Designated use	4
Dimensions	7
Disposal	22

### E

Electrical connection	11
Electrolyte	14
Environment	24

### F

Flow mode	8
-----------	---

### I

Incoming acceptance	6
Installation	4, 6–7
Measuring system	9
Installation instructions	8

### M

Maintenance	18
Materials	24
Measured value	23
Measuring principle	13
Measuring range	23
Measuring system	8–9

### O

Operation	4, 13
Operational safety	5

### P

Polarisation	16
Polarisation time	23
Product structure	6

### R

Response time	23
Return	5, 22

### S

Safety icons	5
Scope of delivery	6
Sensor	
Design	13
Slope	23
Storage	6
Symbols	5

### T

Technical data	23
Temperature compensation	24
Transport	6
Troubleshooting instructions	20

### U

Use	4
-----	---

### W

Wiring	11
--------	----



# Declaration of contamination

Dear customer,

Because of legal determinations and for the safety of our employees and operating equipment, we need this "Declaration of contamination" with your signature before your order can be handled. Please, include the completely filled in declaration with the device and the shipping documents in any case. Add also safety sheets and / or specific handling instructions if necessary.

Type of device /sensor:	_____	Serial no.:	_____
Medium / concentration:	_____	Temperature:	_____ Pressure: _____
Cleaned with:	_____	Conductivity:	_____ Viscosity: _____

**Warning hints for medium used** (mark up the appropriate hints)



radioactive



explosive



caustic



poisonous



harmful to health



biologically hazardous



inflammable



safe

**Reason for return:** \_\_\_\_\_

<b>Company data</b>	
Company: _____	Contact person: _____
_____	_____
Address: _____	Department: _____
_____	Phone: _____
_____	Fax / e-mail: _____
_____	Your order no.: _____

I hereby certify that the returned equipment has been cleaned and decontaminated acc. to good industrial practices and is in compliance with all regulations. This equipment poses no health or safety risks due to contamination.

_____	_____
(Place, date)	(Company stamp and legally binding signature)

[www.endress.com/worldwide](http://www.endress.com/worldwide)

---

**Endress+Hauser**   
People for Process Automation

---

BA388C/07/en/07.06  
Printed in Germany / FM+SGML 6.0 /  
DT

