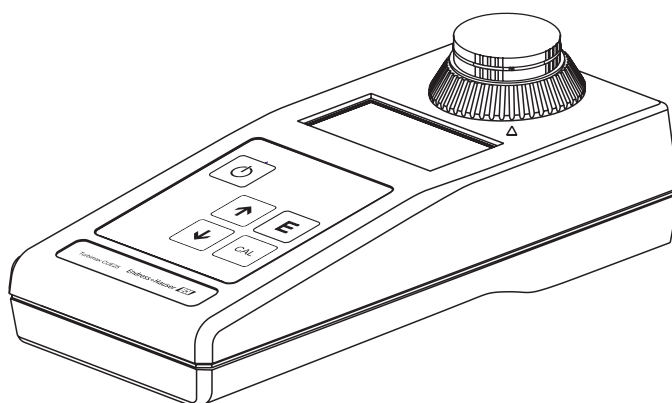


Operating Instructions

Turbimax CUE25 / CUE26

Handheld turbidimeter for field measurement



Brief operating instructions

This explains how to use these Operating Instructions to commission your turbidimeter quickly and safely:

| | |
|----------------------------|--|
| → Page 4 ff. | Safety instructions |
| → Page 5 | General safety instructions and explanations of the safety icons are provided in the section in question. Specific safety instructions are provided at the appropriate position. Their level of importance can be seen from the icon: ⚠ Warning, ⚡ Caution, 📌 Note. |
| ▼ | |
| → Page 8 → Page 9 ff. | Installation |
| | The installation conditions, such as the dimensions of the device, are illustrated here. Here, you can find the steps for installation of the batteries. |
| ▼ | |
| → Page 10 → Page 11 ff. | Operation |
| | Use this section to familiarize yourself with the operation of the device. This section provides information on routine measurement. |
| ▼ | |
| → Page 12 ff. | Calibration |
| | Here, you can find out how to calibrate your turbidimeter. |
| ▼ | |
| → Page 15 ff. | Maintenance |
| | Here, you can find information on important maintenance activities, for example, cleaning the cuvette and replacing the batteries. |
| ▼ | |
| → Page 17 | Accessories |
| | Here, you can find an overview of the accessories which can be supplied. |
| ▼ | |
| → Page 18 | Troubleshooting |
| | If faults occur during operation, use the check lists to localize and remedy them. |
| ▼ | |
| → Page 21 → Page 20 | Technical data |
| | Dimensions Ambient and process conditions, weight, materials etc. |

Table of contents

| | | |
|----------|---|-----------|
| 1 | Safety instructions | 4 |
| 1.1 | Designated use | 4 |
| 1.2 | Installation, commissioning and operation | 4 |
| 1.3 | Operational safety | 4 |
| 1.4 | Return | 4 |
| 1.5 | Notes on safety icons and symbols | 5 |
| 2 | Identification | 6 |
| 2.1 | Device designation | 6 |
| 2.2 | Scope of delivery | 6 |
| 2.3 | Certificates and approvals | 6 |
| 3 | Installation | 7 |
| 3.1 | Quick installation guide | 7 |
| 3.2 | Incoming acceptance, transport, storage | 7 |
| 3.3 | Installation conditions | 8 |
| 3.4 | Installation instructions | 9 |
| 3.5 | Post-installation check | 9 |
| 4 | Operation | 10 |
| 4.1 | Display and operating elements | 10 |
| 4.2 | Key assignment | 10 |
| 4.3 | Routine operation | 11 |
| 4.4 | Instrument calibration | 12 |
| 5 | Maintenance | 15 |
| 5.1 | Cleaning the cuvette | 15 |
| 5.2 | Replacing the batteries | 16 |
| 6 | Accessories | 17 |
| 6.1 | Calibration solutions | 17 |
| 6.2 | Cuvettes | 17 |
| 7 | Troubleshooting | 18 |
| 7.1 | Troubleshooting instructions | 18 |
| 7.2 | System error messages | 18 |
| 7.3 | Battery low indicator | 18 |
| 7.4 | Spare parts | 18 |
| 7.5 | Return | 19 |
| 7.6 | Disposal | 19 |
| 8 | Technical data | 20 |
| 8.1 | Input | 20 |
| 8.2 | Power supply | 20 |
| 8.3 | Performance characteristics | 20 |
| 8.4 | Environment | 20 |
| 8.5 | Process | 20 |
| 8.6 | Mechanical construction | 21 |
| | Index | 22 |

1 Safety instructions

1.1 Designated use

The Turbimax CUE25 / CUE26 turbidimeters are compact handheld meters for turbidity measurement in process water, drinking water and wastewater. The infrared light instrument, CUE25, meets the design criteria on turbidity measurement specified in ISO 7027 and DIN 27027. The white light instrument, CUE26, meets the design criteria specified by US EPA 180.1.

Any other use than the one described here compromises the safety of persons and the entire measuring system and is, therefore, not permitted.

The manufacturer is not liable for damage caused by improper or non-designated use.

1.2 Installation, commissioning and operation

Please note the following items:

- Installation, commissioning, operation and maintenance of the measuring system must only be carried out by trained technical personnel.
The technical personnel must be authorized for the specified activities by the system operator.
- Electrical connection must only be carried out by a certified electrician.
- Technical personnel must have read and understood these Operating Instructions and must adhere to them.
- Before commissioning the entire measuring point, check all the connections for correctness. Ensure that electrical cables and hose connections are not damaged.
- Do not operate damaged products and secure them against unintentional commissioning. Mark the damaged product as being defective.
- Measuring point faults may only be rectified by authorized and specially trained personnel.
- If faults can not be rectified, the products must be taken out of service and secured against unintentional commissioning.
- Repairs not described in these Operating Instructions may only be carried out at the manufacturer's or by the service organisation.

1.3 Operational safety

The measuring system has been designed and tested to the highest standards and left the factory in perfect functioning order.

Relevant regulations and European standards have been met.

As the user, you are responsible for complying with the following safety conditions:

- Installation instructions
- Local prevailing standards and regulations.

Immunity to interference

This instrument has been tested for electromagnetic compatibility in industrial use according to applicable European standards.

Protection against interference as specified above is valid only for an instrument connected according to the instructions in these Operating Instructions.

1.4 Return

If the system has to be repaired, please return it *cleaned* to the sales center responsible. Please use the original packaging, if possible.

1.5 Notes on safety icons and symbols

Safety icons



Warning!

This symbol alerts you to hazards. They can cause serious damage to the instrument or to persons if ignored.



Caution!

This symbol alerts you to possible faults which could arise from incorrect operation. They could cause damage to the instrument if ignored.



Note!

This symbol indicates important items of information.

Electrical symbols



Direct Current (DC)

A terminal at which DC is applied or through which DC flows.



Alternating Current (AC)

A terminal at which (sine-form) AC is applied or through which AC flows.



Ground connecting

A terminal, which, from the user's point of view, is already grounded using a grounding system.



Protective ground terminal

A terminal which must be grounded before other connections may be set up.



Alarm relay



Input



Output



DC voltage source



Temperature sensor

2 Identification

2.1 Device designation

2.1.1 Nameplate

Compare the order number on the nameplate with your order.
The device version can be identified from this order number.

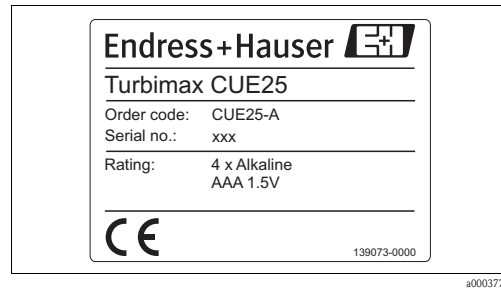


Fig. 1: CUE25 nameplate (example)

2.1.2 Ordering information

CUE25 handheld, infrared

| Version | |
|---------|---------------------|
| A | Standard |
| CUE25- | complete order code |

CUE26 handheld, white light

| Version | |
|---------|---------------------|
| A | Standard |
| CUE26- | complete order code |

2.2 Scope of delivery

The scope of delivery comprises:

- 1 Turbimax CUE25 /CUE26 turbidimeter with 4 AAA alkaline batteries
- 1 Calibration kit CUE25 / CUE26 including
 - 0.02 NTU standard
 - 10.0 NTU standard
 - 1000 NTU standard
- 2 Empty cuvettes and Kimwipes®
- 1 Operating Instructions BA397C/07/en
- 1 Instruction card

If you have any questions, please contact your supplier or your sales center responsible.

2.3 Certificates and approvals

Declaration of conformity

The product meets the legal requirements of the harmonized European standards.
The manufacturer confirms compliance with the standards by affixing the **CE** symbol.

3 Installation

3.1 Quick installation guide

3.1.1 Measuring system

The measuring system comprises:

- Turbimax CUE25 / CUE26 turbidimeter
- Sample cuvette with light shield cap
- Indexing ring

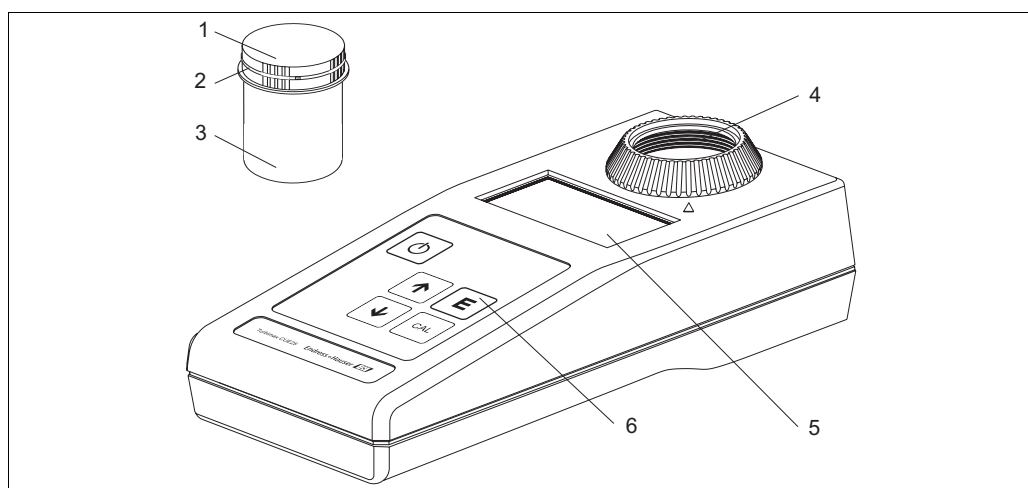


Fig. 2: Turbimax CUE25 system (example)

- | | | | |
|---|--------------------|---|--------------|
| 1 | Black light shield | 4 | Optical well |
| 2 | Indexing ring | 5 | Display |
| 3 | Sample cuvette | 6 | Touch pad |

3.2 Incoming acceptance, transport, storage

- Make sure the packaging is undamaged!
Inform the supplier about damage to the packaging. Keep the damaged packaging until the matter has been settled.
- Make sure the contents are undamaged!
Inform the supplier about damage to the delivery contents. Keep the damaged products until the matter has been settled.
- Check that the scope of delivery is complete and agrees with your order and the shipping documents.
- The packaging material used to store or to transport the product must provide shock protection and humidity protection. The original packaging offers the best protection. Also, keep to the approved ambient conditions (see "Technical data").
- If you have any questions, please contact your supplier or your sales center responsible.

3.3 Installation conditions

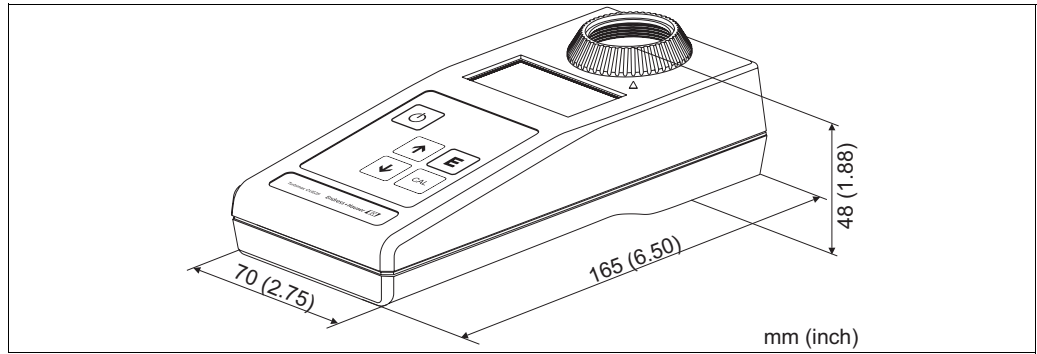


Fig. 3: Dimensions CUE25 / CUE26

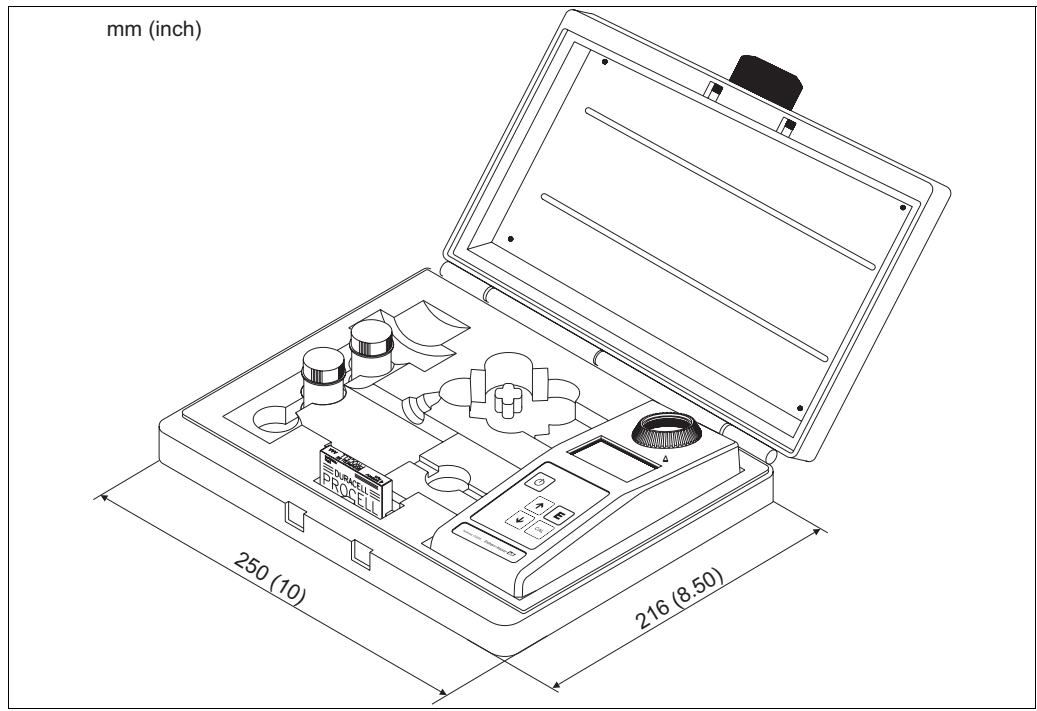


Fig. 4: Dimensions carry case

3.4 Installation instructions

The Turbimax is supplied with 4 AAA alkaline batteries. You need to install the batteries before you can use the instrument.

To install the batteries, proceed as follows:

1. Place the instrument upside down on a soft surface.
2. Remove the two screws (pos. 1) securing the battery cover (pos. 2). Lift the cover off.
3. Place the supplied four AAA alkaline batteries (pos. 3) into the battery compartment (pos. 4) ensuring the correct polarity.
4. Replace the battery cover and fasten the two screws carefully to ensure a watertight seal.

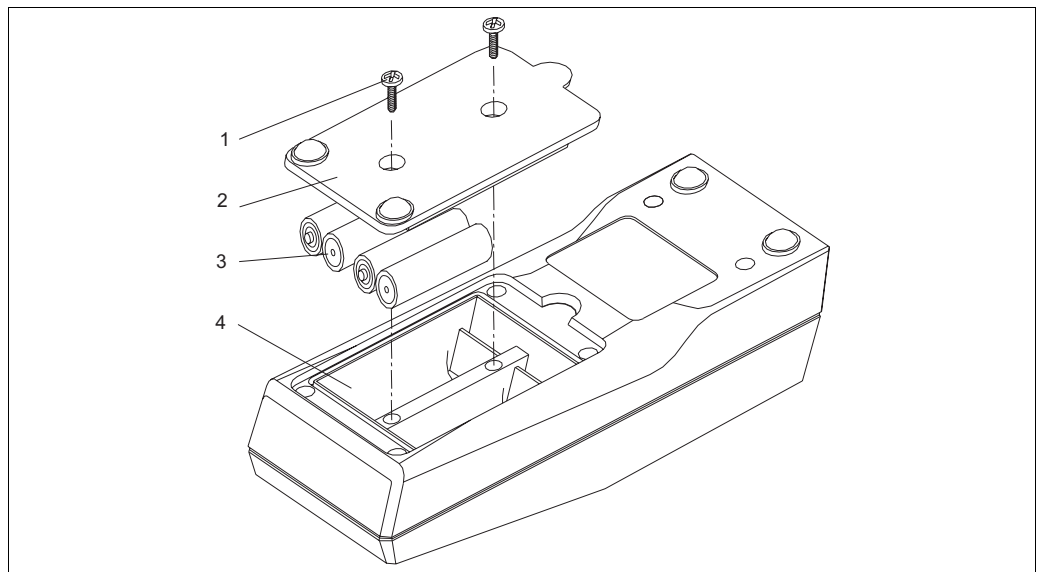


Fig. 5: Detailed view of the battery compartment

3.5 Post-installation check

Check that the battery cover is correctly placed and fastened to ensure the watertight seal of the instrument.

4 Operation

4.1 Display and operating elements

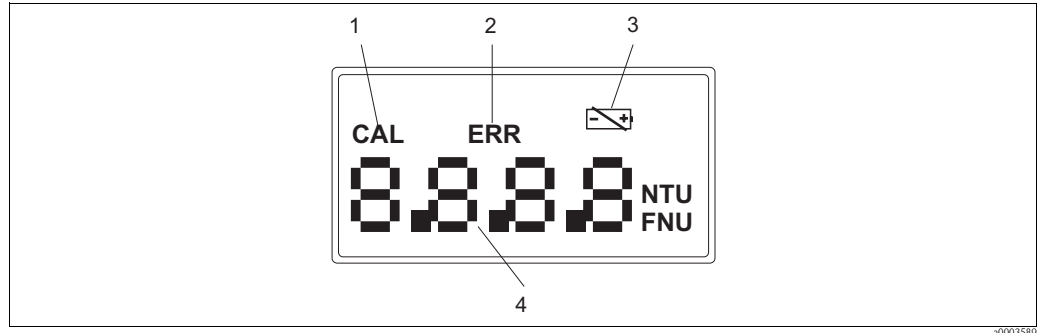


Abb. 6: Display

- 1 Icon indicating calibration mode
- 2 Icon indicating error conditions
- 3 Icon indicating low battery
- 4 Display of turbidity levels and user guidance in calibration routine

4.2 Key assignment

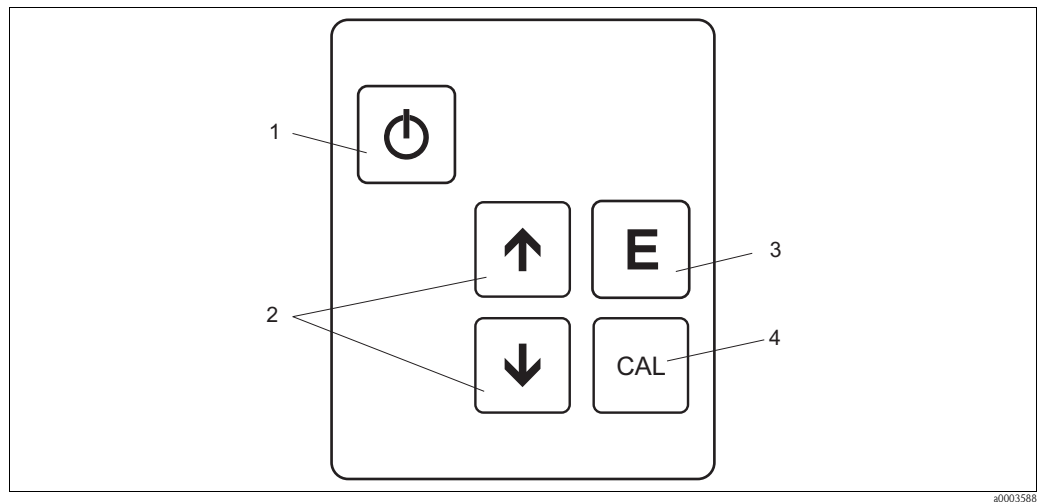







Fig. 7: Operating elements

- 1  key used to turn the Turbimax on or off
- 2   keys used to set numerical values and to scroll through the list
- 3  key used to index a sample when pressed and held and to start a reading or calibration when released
- 4  key used to enter or exit calibration mode




4.3 Routine operation



Caution!

Never pour liquid directly into the sample well of the instrument. Always use a cuvette. The Turbimax will accurately measure the turbidity of a sample using only cuvettes with the black light shield on the cuvette (provided by Endress+Hauser).

Perform the following steps to measure the turbidity of a sample:

1. Turn the instrument on by pressing the  key for 1 second.
2. Sample approximately 100 ml of the process stream as you would normally do for turbidity measurement.
3. Obtain a clean and dry sample cuvette.
4. Rinse the cuvette with approximately 10 ml of the sample water (2/3 of cuvette volume), capping the cuvette with the black light shield cap and inverting several times.
5. Discard the 10 ml of used sample and repeat the rinsing procedure two more times.
6. Completely fill the rinsed cuvette with the remaining portion (approximately 15 ml) of the grab sample and then cap the cuvette with the black light shield cap. Ensure that the outside of the cuvette is dry, clean and free from smudges¹⁾.
7. Place the cuvette into the instrument and press it down until it snaps fully into the sample well.
8. Index the cuvette to the lowest reading:
 - Press and hold the  key.
 - Rotate the cuvette slowly throughout one complete revolution (360°)
 - While rotating the sample cuvette, observe the display and locate the position in which the cuvette provides the lowest turbidity reading.
 - This position is the indexed position of the cuvette.
9. Once the cuvette is indexed, release the  key to display the measured turbidity.
10. Repeat steps 2 through 9 for all of your samples.



Note!

- The instrument will turn off after approximately 5 minutes if no keys are pressed.
- To minimize drift, indexing is allowed for only a short period of time. After this period, the calibration or reading of the sample is automatically initiated.
- The value displayed during indexing is for the purpose indexing only. The final reading may vary from the indexing value.

1) Any typical glass cleaner can be used along with a lint-free cloth, or tissue, to clean the outside of the cuvette.

4.4 Instrument calibration

The instrument was calibrated and tested prior to leaving the factory. Therefore, it is possible to use it directly out of the box. However, recalibration of the instrument is recommended to help with familiarization and the operation of the instrument and the calibration procedures. In addition, recalibration is recommended at least once every three months²⁾.

The instrument requires three standards to be fully calibrated.

4.4.1 Calibration standards

We recommend that the following standards be used during calibration to achieve the full-scale accuracy stated in this manual:

- 0.02 NTU calibration standard
- 10.0 NTU calibration standard
- 1000 NTU calibration standard

These primary calibration standards are more stable than Formazin and have a minimum shelf life of 12 months. Prior to recalibration, review the expiration dates to ensure that the standards have not expired.

If you use Formazin to calibrate the instrument, make sure that a fresh stock suspension of Formazin is used to achieve the accuracy quoted for the instrument.



Note!


The 10.0 NTU standard is only guaranteed to hold its value for 12 months when stored in the plastic bottle. After pouring it into the glass cuvette, it should be used immediately for calibration and then be disposed of. If the 10.0 NTU standard is stored in the glass cuvette for extended periods of time, it should be used as a reference standard only.

4.4.2 Indexing calibration cuvettes

To achieve greatest accuracy and account for normal scratches and aberrations in cuvette glass when calibrating, we recommend indexing the cuvettes.

Standards and standard kits purchased from Endress+Hauser are supplied with indexing rings.

The following steps allow repeatable indexing of calibration standards:

1. Press and hold the  key.
2. Slowly rotate the standard inside the optical well, one complete revolution (360°) pausing between the increments to allow the display to update.
3. While rotating the standard slowly, observe the measured turbidity and locate the position of the cuvette having the lowest reading.
4. With the calibration standard positioned at the location having the lowest turbidity reading, install the indexing ring over the cap on the standard so that the pointer of the indexing ring aligns with the arrow on the instrument.


When using the standards in future, always insert the standard so that the pointer of the indexing ring aligns with the arrow. Slowly rotate the standard back and forth about 5° to find the lowest point. The standard is then indexed and ready for use.

2) The EPA recommends that on-line turbidimeters be calibrated with a primary standard at least once every three months if they are to be used for EPA reporting.



4.4.3 Calibration procedure

To perform a full range calibration, proceed as follows:



Step one:

1. Press the  key to select the calibration function.
The "Cal" icon will illuminate on the display with "1000" flashing indicating the standard required for this step of the calibration.





2. Insert the requested 1000 NTU standard into the optical well and press down until the cuvette snaps fully into the instrument. Align the indexing ring with the arrow on the instrument.
3. Press and hold the  key and fine-tune the standard to the lowest value on the display by slowly rotating it back and forth about 5°.
4. Release the  key to initiate the calibration. The display will show a 30 second count down.
5. When the instrument has completed calibration on the 1000 NTU, it will briefly display "1000" to indicate that it was calibrated.

Step two:

1. The instrument prompts for the 10 NTU standard with a flashing 10.0.
2. Insert the 10 NTU standard into the optical well and press down until the cuvette snaps fully into the instrument. Align the indexing ring with the arrow on the instrument.
3. Press and hold the  key and fine-tune the standard to the lowest value on the display by slowly rotating it back and forth about 5°.
4. Release the  key to initiate the calibration. The display will show a 60 second count down.
5. When the instrument has completed calibration on the 10.0 NTU, it will briefly display "10.0" to indicate that it was calibrated.




Step three:

1. The instrument prompts for the 0.02 NTU standard with a flashing "0.02".
2. Insert the 0.02 NTU standard into the optical well and press down until the cuvette snaps fully into the instrument. Align the indexing ring with the arrow on the instrument.
3. Press and hold the  key and fine-tune the standard to the lowest value on the display by slowly rotating it back and forth about 5°.
4. Release the  key to initiate calibration. The instrument will show a 30 second count down.
5. When the instrument has completed calibration on the 0.02 NTU standard, it returns to the read mode and is ready to read.



a0003815

**Note!**

- If you wish to exit the calibration mode, you may do so at the end of any step simply by pressing the  key. The instrument will store any of the values calibrated prior to exiting.
- You can cycle through the required calibration points (0.02 NTU, 10 NTU, 1000 NTU) by pressing either the  or  keys to individually calibrate with a particular calibration standard.
- The required calibration values are set in software and cannot be changed.

Calibration error

If the calibration failed, the instrument will display the error shown below.






a0003817

Calibration failure can have the following reasons:

- Bad calibration standards
- Wrong order of calibration standards

Either check the standards and recalibrate or restore the factory calibration by performing the following operation:

1. Push and hold the  key.
2. Push and release the  key and then release the  key.
3. The instrument will turn itself off. When it is turned on again, the error screen will be gone.

**Note!**

After restoring factory calibration, the instrument may operate with reduced accuracy until a new calibration can be performed.

5 Maintenance

If the Turbimax CUE25 / CUE26 is not kept in the supplied case, when not in use, make sure that the instrument has been turned off and that a clean sample cuvette fitted with a black light shield cap has been placed in the optical well. This will ensure that a minimum amount of dust and debris will be able to settle on the optics of the instrument.

Take all the necessary measures in time to ensure the operational safety and reliability of the entire measuring system.

Maintenance work at the instrument comprises:

- Cleaning the cuvette
- Replacing the batteries

5.1 Cleaning the cuvette

Measurement cuvettes should be clean and free of marks or scratches. To clean a cuvette, proceed as follows:

1. Clean the interior and exterior with a detergent solution.
2. Rinse the cuvette thoroughly 8 to 10 times with distilled or deionized water to eliminate the possibility of detergent build-up and streaking.
3. Store the cleaned and dried cuvette with the black light shield cap on the cuvette.

During normal operation you may use any typical glass cleaner along with a lint free cloth, or tissue, to clean the outside of the cuvettes.

Condensation may appear on the cuvette when a sample is very cold and the relative humidity is high. When this happens, the turbidity displayed may be higher than the actual turbidity due to light scattered by the condensate on the cuvette. To alleviate the problem, either coat the cuvette with an anti-fogging agent, or by running warm water over the cuvette for a short period of time to warm the sample prior to measurement.

5.2 Replacing the batteries

The Turbimax will periodically require new batteries to function properly. This will be indicated by the battery icon on the display.

To replace the batteries proceed as follows:

1. Turn the instrument off and place it upside down on a soft surface.
2. Remove the two screws (pos. 1) securing the battery cover (pos. 2). Lift the cover off.
3. Remove the old batteries.
4. Place four new AAA batteries (pos. 3) into the battery compartment (pos. 4) ensuring the correct polarity.
5. Replace the battery cover and fasten the two screws carefully to ensure a watertight seal.
6. Dispose of used batteries in accordance with all federal, state and local regulations.

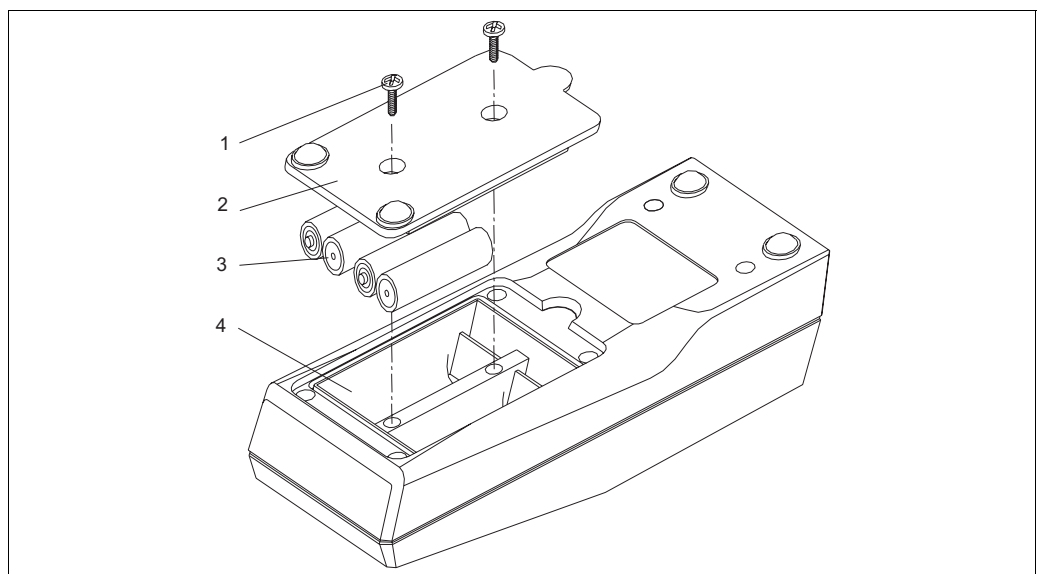


Fig. 8: Detailed view of the battery compartment

6 Accessories

6.1 Calibration solutions

Calibration kit CUE25 / CUE26, full range

- 0.02 NTU
- 10.0 NTU
- 1000 NTU

Order no.: 51518582

6.2 Cuvettes

- Sample cuvettes CUE25 / CUE26
incl. caps, 3 pcs.

Order no.: 51518583

7 Troubleshooting

7.1 Troubleshooting instructions

The instrument routinely performs self-diagnostics and provides you with two levels of specific diagnostic information.

- Battery low indicator
- System error messages

Refer to the sections "Battery low indicator" and "System error messages" to localize and rectify a warning condition or an error.

7.2 System error messages

Normally, the cause of an error message is external to the instrument. The following table lists the error messages and their associated meanings:

| Error message | Typical cause | Tests and / or corrective measures |
|------------------------------------|--|--|
| "Err" icon on | Internal error | Contact your responsible service. |
| "Err" icon on; display reads "CAL" | Bad standards or standards in wrong order. | Check the standards and recalibrate the instrument. See section "Instrument calibration" for detailed information. |

7.3 Battery low indicator

| Warning | Possible cause | Tests and / or corrective measures |
|-----------------------|---------------------|--|
| Flashing battery icon | Batteries are low | Batteries need to be replaced but the readings displayed are still accurate. |
| Solid battery icon | Power level too low | Readings may be out of specification. Replace the batteries as soon as possible to ensure that the Turbimax will continue to function properly. If the batteries get too low to perform, the instrument will turn off and may not turn on until the batteries have been replaced. See section "Replacing the batteries" for more information. |

7.4 Spare parts

| Designation and content | Order number spare part kit |
|--------------------------|---|
| Rechargeable battery kit | Please contact the responsible service. |

7.5 Return

If the system has to be repaired, please return it *cleaned* to the sales center responsible.
Please use the original packaging, if possible.

7.6 Disposal

The device contains electronic components and must therefore be disposed of in accordance with regulations on the disposal of electronic waste.
Please observe local regulations.

8 Technical data

8.1 Input

| | |
|-------------------|----------------------|
| Measured variable | Turbidity |
| Measuring range | 0.01 to 1100 NTU/FNU |

8.2 Power supply

| | |
|----------------|---|
| Batteries | 4 AAA alkaline batteries (over 5000 tests) |
| Supply voltage | 4 x 1.5 V |

8.3 Performance characteristics

| | | |
|------------------------|--|--|
| Response time | < 14 s | |
| Reference temperature | 25 °C (77 °F) | |
| Resolution | 0.01 NTU below 100 NTU 0.1 NTU in the range 100.0 to 999.9 NTU 1.0 NTU in the range 1000 to 1100 NTU | |
| Maximum measured error | 0 to 500 NTU: 500 to 1100 NTU: | ±2 % of reading or 0.01 NTU ±3 % of reading |
| Repeatability | ±2 % of reading | |

8.4 Environment

| | |
|--------------------|--------------------------------------|
| Ingress protection | IP 67 / NEMA 4x |
| Insulation rating | Double insulated, pollution degree 2 |
| Relative humidity | max. 90%, non-condensing |

8.5 Process

| | |
|--------------------------|---------------------------|
| Process temperature | 0 to 50 °C / 32 to 122 °F |
| Medium temperature range | 0 to 50 °C / 32 to 122 °F |
| Sample size | 10 to 15 ml |

8.6 Mechanical construction

| | | |
|---------------------|---|---------------------------------------|
| Dimensions | Instrument: H x W x L: 48 x 70 x 165 mm (1.875" x 2.75" x 6.50") | |
| | Instrument in case: H x W x L: 63 x 250 x 216 mm (2.50" x 10" x 8.50") | |
| Weight | 1.2 kg (2.7 lbs.) | |
| Materials | Instrument housing: | ABS, injection molded |
| | Sample cuvette: | Borosilicate glass |
| | Carry case: | High density polyethylene blow molded |
| Light source | Turbimax CUE25: | Infrared LED, 860 nm |
| | Turbimax CUE26: | Tungsten lamp, ~600 nm, 2250 °K |

Index

| | | |
|-----------------------------|----------|--|
| A | | |
| Accessories | 17 | |
| B | | |
| Battery indicator | 18 | |
| Battery replacement | 16 | |
| C | | |
| Calibration | 12 | |
| Checking | | |
| Installation | 9 | |
| Cleaning | | |
| Cuvette | 15 | |
| Commissioning | 4 | |
| Cuvette cleaning | 15 | |
| D | | |
| Declaration of conformity | 6 | |
| Designated use | 4 | |
| Display | 10 | |
| E | | |
| Electrical icons | 5 | |
| Environment | 20 | |
| Error messages | 18 | |
| I | | |
| Icons | | |
| Electrical | 5 | |
| Safety symbols | 5 | |
| Immunity to interference | 4 | |
| Incoming acceptance | 7 | |
| Input | 20 | |
| Installation | 4, 7–9 | |
| Instrument calibration | 12 | |
| K | | |
| Key assignment | 10 | |
| M | | |
| Maintenance | 15 | |
| Batteries | 16 | |
| Cuvette | 15 | |
| Measuring system | 7 | |
| Mechanical construction | 21 | |
| N | | |
| Nameplate | 6 | |
| O | | |
| Operation | 4, 10–11 | |
| Operational safety | 4 | |
| Ordering information | 6 | |
| P | | |
| Performance characteristics | 20 | |
| Power supply | 20 | |
| Process | 20 | |
| Product structure | 6 | |
| R | | |
| Return | 4 | |
| Routine operation | 11 | |
| S | | |
| Safety icons | 5 | |
| Scope of delivery | 6 | |
| Spare parts | 18 | |
| Storage | 7 | |
| Symbols | 5 | |
| T | | |
| Technical data | 20 | |
| Transport | 7 | |
| Troubleshooting | 18 | |
| Battery indicator | 18 | |
| Fault detection | 18 | |
| System error messages | 18 | |
| U | | |
| Use | | |
| designated | 4 | |

www.endress.com/worldwide

Endress+Hauser 
People for Process Automation

