



Level



Pressure



Flow



Temperature



Liquid  
Analysis



Registration



Systems  
Components



Services



Solutions

Operating instructions

# Cleanfit P CPA473

Retractable Process Assembly

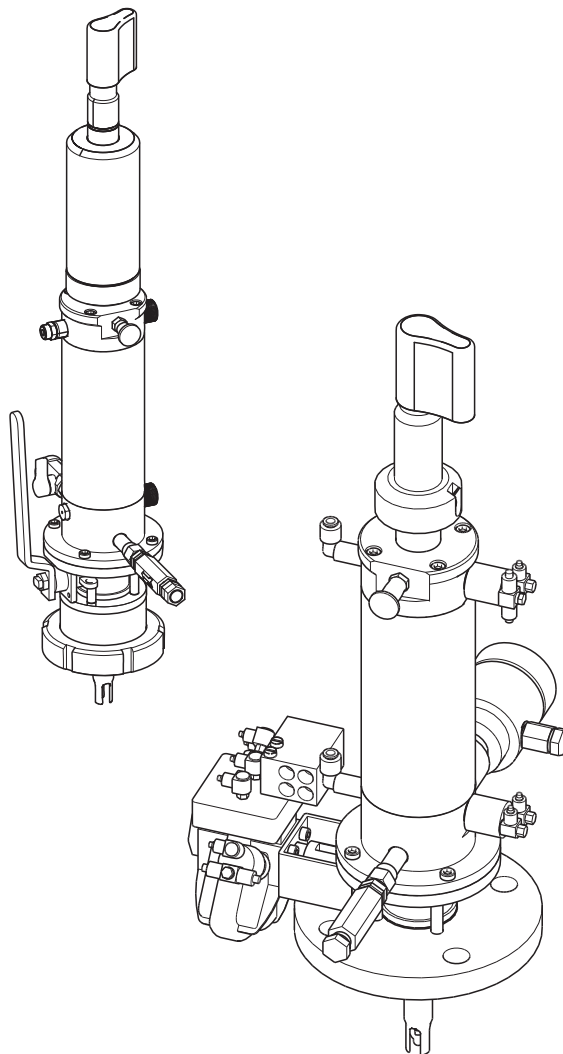



## Table of contents

<b>1</b>	<b>Safety instructions</b>	<b>4</b>	<b>5</b>	<b>Maintenance</b>	<b>28</b>
1.1	Designated use	4	5.1	Cleaning the assembly	28
1.2	Installation, commissioning and operation	4	5.1.1	Manually operated assembly	28
1.3	Operational safety	4	5.1.2	Pneumatically operated assembly	28
1.4	Return	4	5.2	Cleaning the sensor	28
1.5	Notes on safety icons and symbols	5	5.3	Cleaning agents	29
<b>2</b>	<b>Identification</b>	<b>6</b>	5.4	Notes on calibration	29
2.1	Nameplate	6	5.5	Replacing seals	30
2.2	Scope of delivery	6	<b>6</b>	<b>Accessories</b>	<b>34</b>
2.3	Certificates and approvals	6	6.1	Process adapter	34
2.4	Product structure	7	6.2	Water filter and pressure reducer	34
<b>3</b>	<b>Installation</b>	<b>8</b>	6.3	Rinse connection adapter	35
3.1	Incoming acceptance, transport, storage	8	6.4	Flow assembly	35
3.2	Installation conditions	8	6.5	Inlet and outlet safety seal	35
3.2.1	Notes on installation	8	6.6	Hose connectors for rinse chamber	36
3.2.2	Dimensions	9	6.7	Limit position switches	36
3.2.3	Process connections	10	6.8	Retrofit kit	36
3.2.4	Process pressure	11	6.9	Sensors	37
3.2.5	Sealing system	12	6.9.1	Glass electrodes	37
3.2.6	Sealing-water function	12	6.9.2	ISFET sensors	37
3.2.7	Scraper function	13	6.10	Transmitters	38
3.3	Measuring system	14	6.11	Measuring, cleaning and calibration systems	38
3.4	Installing the assembly into the process	15	<b>7</b>	<b>Trouble-shooting</b>	<b>39</b>
3.5	Compressed air connection	15	7.1	Replacing damaged parts	39
3.5.1	Limit position switches	15	7.2	Replacing parts without process interrupt	39
3.5.2	Connections	16	7.3	Replacing parts with process interrupt	39
3.6	Rinse water connection	17	7.4	Spare part kits	40
3.6.1	Optional inlet and outlet safety seals	18	7.5	Return	44
3.7	Sensor installation	20	7.6	Disposal	44
3.7.1	Preparing sensor and assembly	20	<b>8</b>	<b>Technical data</b>	<b>45</b>
3.7.2	Gel sensor installation	21	8.1	Process	45
3.7.3	Sensor with liquid KCl electrolyte	22	8.2	Environment	46
3.8	Post-installation check	22	8.3	Mechanical construction	46
<b>4</b>	<b>Operation</b>	<b>23</b>	<b>Index</b>	<b>48</b>	
4.1	First commissioning	23			
4.2	Operating elements	23			
4.3	Manual operation	23			
4.4	Pneumatic operation	24			
4.4.1	Connections and limit position switches overview	24			
4.4.2	Indication of the ball-valve position	25			
4.4.3	Moving from "Service" position into "Measuring" position	26			
4.4.4	Moving from "Measuring" position into "Service" position	27			

# 1 Safety instructions

## 1.1 Designated use

The manually or pneumatically operated retractable assembly Cleanfit P CPA473 is designed for installing pH/redox sensors in tanks and pipes.

Its mechanical design permits its use in pressurized systems (see "Technical data").

The operation of the assembly outside the specified temperature and pressure ranges can result in personal injury and material damage.

Any other use than the one described here compromises the safety of persons and the entire measuring system and is not permitted.

The manufacturer is not liable for damage caused by improper or non-designated use.

## 1.2 Installation, commissioning and operation

Please note the following items:

- Installation, commissioning, operation and maintenance of the measuring system must only be carried out by trained technical personnel.  
Trained personnel must be authorized for the specified activities by the system operator.
- Electrical connection must only be carried out by a certified electrician.
- Technical personnel must have read and understood these Operating Instructions and must adhere to them.
- Before commissioning the entire measuring point, check all the connections. Ensure that electrical cables and hose connections are not damaged.
- Do not operate damaged products and secure them against unintentional commissioning. Mark the damaged product as being defective.
- Measuring point faults may only be rectified by authorized and specially trained personnel.
- If faults can not be rectified, the products must be taken out of service and secured against unintentional commissioning.
- Repairs not described in these Operating Instructions may only be carried out at the manufacturer's or by the service organization.

## 1.3 Operational safety

The assembly has been designed and tested in accordance with the latest industry standards and left the factory in perfect functioning order.

Relevant regulations and standards have been met.

As the user, you are responsible for complying with the following safety conditions:

- Installation instructions
- Local prevailing standards and regulations.

## 1.4 Return

If the assembly has to be repaired, please return it **cleaned** to the appropriate sales center.

Please use the original packaging, if possible.

Please enclose the completed "Declaration of De-Contamination" (copy the second to last page of these Operating Instructions) with the packaging and the transportation documents.

No repair without completed "Declaration of De-Contamination"!

## 1.5 Notes on safety icons and symbols



Warning!

This symbol alerts you to hazards that can cause serious damage to the instrument or to persons if ignored.



Caution!

This symbol alerts you to possible faults which could arise from incorrect operation. They could cause damage to the instrument if ignored.



Note!

This symbol indicates important items of information.

## 2 Identification

### 2.1 Nameplate

You can identify the assembly version by the order code on the nameplate. Please compare this code with your order.

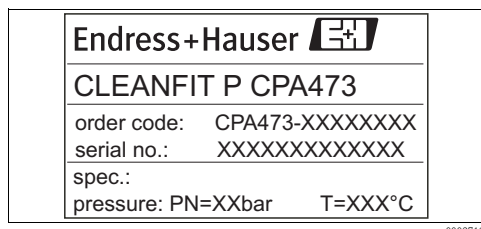

On the nameplate you will find the following information:

- Order code
- Serial number
- Permissible pressure
- Permissible temperature

Fig. 1: Example of a nameplate

For possible assembly versions and the resulting order codes see the product structure.

### 2.2 Scope of delivery

The scope of delivery comprises:

- Cleanfit assembly (ordered version)
- Operating Instructions (English)

If you have any questions, please contact your supplier or your local sales center.

### 2.3 Certificates and approvals

Inspection certificate 3.1 acc. to EN 10204 on demand.

## 2.4 Product structure

Assembly drive, ball valve									
A									Assembly + ball valve: manual (convertable to pneumatic only with stainless steel pressure cylinder)
B									Assembly: pneumatic, ball valve: manual, without limit position switches (retrofitable)
C									Assembly: pneumatic, ball valve: manual, with pneumatic limit position switches
D									Assembly: pneumatic, ball valve: manual, with electric limit position switches (Ex and Non-Ex)
E									Assembly + ball valve: pneumatic, with pneumatic limit position switches
F									Assembly + ball valve: pneumatic, with electric limit position switches (Ex and Non-Ex)
Y									Special version acc. to customer specification
Assembly version									
									1 Max. 80 °C (176 °F), max. 6 bar (87 psi), with PEEK scraper (PA cylinder)
									2 Heavy duty version: max. 140 °C (284 °F), max. 6 bar (87 psi), with PEEK scraper (SS cylinder)
									3 Max. 80 °C (176 °F), max. 6 bar (87 psi), without PEEK scraper, i.e. the rinse chamber is <b>not</b> sealed off the medium! (PA cylinder)
									4 Heavy duty version: max. 140 °C (284 °F), max. 6 bar (87 psi), without PEEK scraper, i.e. the rinse chamber is <b>not</b> sealed off the medium! (SS cylinder)
									5 Heavy duty version: max. 140 °C (284 °F), max. 6 bar (87 psi), with PEEK scraper (SS cylinder/flange)
									9 Special version acc. to customer specification
Electrode type									
									A For gel electrodes and pH ISFET sensors with Pg 13.5 (length: 225 mm (8.9") or 360 mm (14.2"))
									B For liquid KCl electrodes and ISFET sensors with Pg 13.5 and hose connection head (type ESS) (425 mm)
									Y Special version acc. to customer specification
Immersion depth									
									1 Short version up to 100 mm (3.94") with PA cylinder (possible sensor lengths: type A = 225 mm (8.9"), type B = 425 mm (16.7")) Assembly versions 1 and 3 only!
									2 Short version up to 100 mm (3.94") with stainless steel 1.4404 (AISI 316L) cylinder (possible sensor lengths: type A = 225 mm (8.9"), type B = 425 mm (16.7")) Assembly versions 2 and 4 only!
									3 Long version up to 235 mm (9.25") with PA cylinder (possible sensor lengths: type A = 360 mm (14.2")) Assembly versions 1 and 3 only!
									4 Long version up to 235 mm (9.25 inches) with stainless steel 1.4404 (AISI 316L) cylinder (possible sensor lengths: type A = 360 mm (14.2")) Assembly versions 2, 4 and 5 only!
									9 Special version acc. to customer specification
Assembly material (in contact with medium)									
									A Stainless steel 1.4404 (AISI 316L)
									B Stainless steel 1.4404 (AISI 316L) with test certificate 3.1 acc. to EN 10204
									Y Special version acc. to customer specification
Seal material (in contact with medium)									
									1 EPDM (for food applications preferred)
									2 FPM (Viton®, for process applications preferred)
									3 Perfluoroelastomer (KALREZ®)
									9 Special version acc. to customer specification
Process connection									
									A Internal thread G 1 ¼ with thread adapter nut
									D Dairy fitting DN 65 (DIN 11851) For flow assembly CPA240 (immersion depths 1 and 2 only!)
									G Flange DN 50, PN 16
									H Flange ANSI 2", 150 lbs
									Y Special version acc. to customer specification
Optional equipment									
									3 With pneumatic inlet/outlet safety seal (2 x G ¼ internal thread / PVDF safety plug)
									4 With pneumatic inlet/outlet safety seal (2 x NPT ¼" internal thread / PVDF safety plug)
									5 With manual inlet/outlet safety seal (2 x G ¼ internal thread / PVDF safety plug)
									6 With manual inlet/outlet safety seal (2 x NPT ¼" internal thread / PVDF safety plug)
									7 With rinse connection sockets, 2 x G ¼ internal thread ( <b>version 1, 2 only!</b> ) (with PVDF safety plug)
									8 With rinse connection sockets 2 x NPT ¼" internal thread ( <b>version 1, 2 only!</b> ) (with PVDF safety plug)
									9 Special version acc. to customer specification
CPA473-									complete order code

## 3 Installation

### 3.1 Incoming acceptance, transport, storage

- Make sure the packaging is undamaged!  
Inform the supplier about any damage to the packaging.  
Keep the damaged packaging until the matter has been settled.
- Make sure the contents are undamaged!  
Inform the supplier about damage to the contents. Keep the damaged products until the matter has been settled.
- Check that the order is complete and agrees with your shipping documents.
- The packaging material used to store or to transport the product must provide shock protection and humidity protection. The original packaging offers the best protection. Also, keep to the approved ambient conditions (see "Technical data").
- If you have any questions, please contact your supplier or your local sales center.

### 3.2 Installation conditions

#### 3.2.1 Notes on installation

The assembly is designed for installation on tanks and pipes. Suitable nozzles must be available for this.

Consider the specified pressure and temperature ranges in the chapter "Technical data".



Note!

- When using standard glass sensors, only installation positions are permitted in which the middle axis of the assembly lies at a minimum angle of 15° from the horizontal (see diagram).  
Otherwise, there will not be a reliable contact between the inner side of the pH membrane and the inner terminal leads via the electrolytes.
- When using an ISFET Tophit sensor, there are, in principle, no restrictions for the installation position. An installation angle of 0 to 180° is, however, recommended. An overhead installation is possible.

A	Glass electrode:	Installation angle of at least 15° from the horizontal
B	ISFET pH-sensor Tophit:	No restrictions, recommended 0 ... 180°

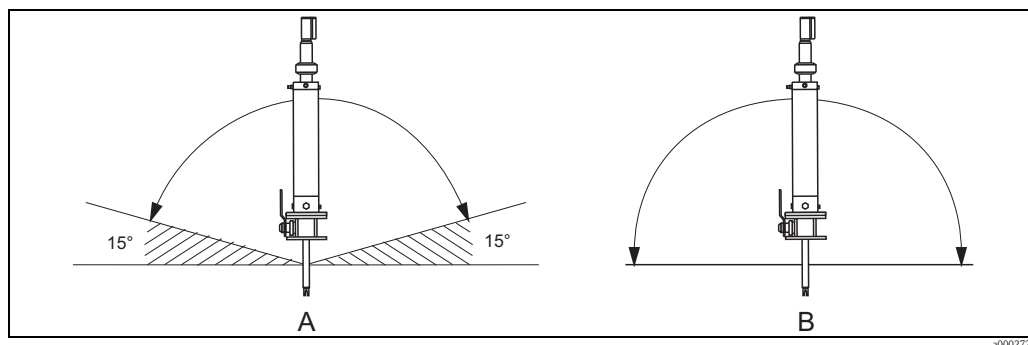

Fig. 2: Permitted orientations depending on the sensor used



Caution!

- For all assemblies with stainless steel pressure cylinders, we recommend to use a flanged version when installing with inclined orientation. Otherwise, the weight of the assembly could affect the safety of the process connection.
- Avoid a siphon effect<sup>1)</sup> at the rinse chamber outlet when installing with inclined orientation. The inlet to the rinse chamber must be from below.

1) Siphon effect: line emptied by vacuum





Note!

- The minimum diameter for direct installation in pipework is DN 50. This diameter is required so that the assembly has sufficient distance from the pipe wall when brought into the "Measuring" position.
- When designing the installation nozzle, please observe the total immersion depth in operation (sensor holder not inserted). Ensure that the sensor is always immersed in the medium in operation (see "Dimensions").

### 3.2.2 Dimensions

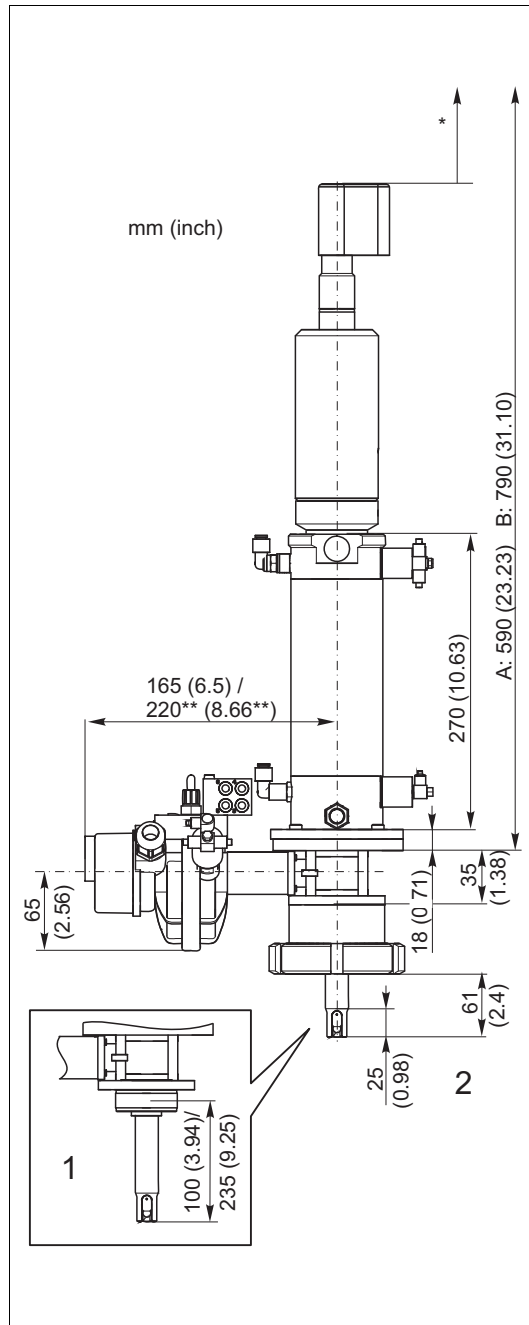

Fig. 3: Version: pneumatic, short, for KCl sensors

- 1 G1/4, short version / long version
- 2 With dairy fitting there is only a short version!
- \* Stroke
- \*\* Version with electric limit position switches

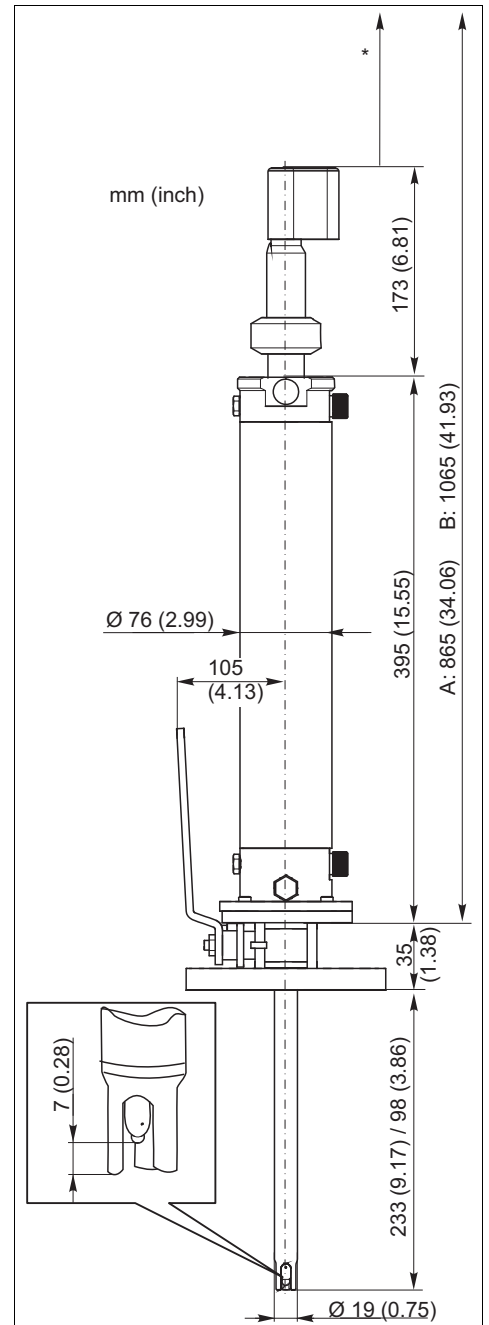

Fig. 4: Version: manual, long, for gel sensors. flange

- long version / short version
- A Assembly in service position
- B Assembly in service position plus required mounting clearance
- \* Stroke

### 3.2.3 Process connections

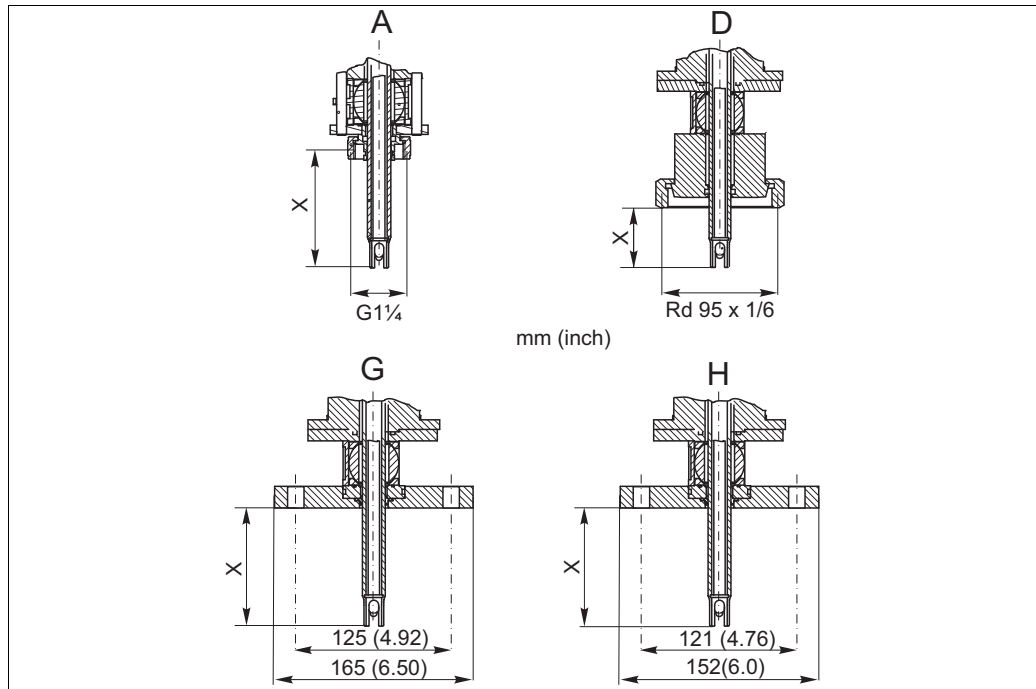

Fig. 5: Process connections

Process connection		X short version	X long version
A	G1 1/4 internal thread	100 mm (3.94")	235 mm (9.25")
D	Dairy fitting DN 65	61 mm (2.40")	not available
G	Flange DN 50	98 mm (3.86")	233 mm (9.17")
H	Flange ANSI 2"	98 mm (3.86")	233 mm (9.17")

### 3.2.4 Process pressure

Pay attention to the specification of the process pressure!

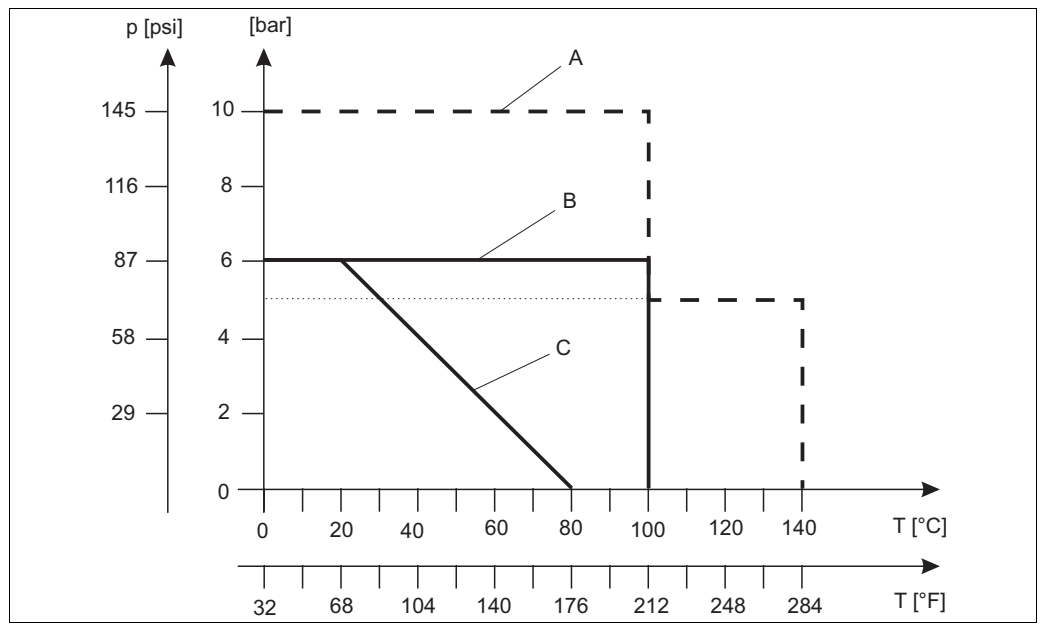

Fig. 6: Pressure-temperature diagram depending on the assembly material

- A Pressure cylinder (assembly) stainless steel 1.4404 (AISI 316L), short-term (max. 1h)
- B Pressure cylinder (assembly) stainless steel 1.4404 (AISI 316L)
- C Pressure cylinder (assembly) PA



Caution!

For manual insertion/retraction of the assembly the process pressure may not exceed 4 bar (58 psi)!

### 3.2.5 Sealing system

The patented packing sleeve (made of PEEK) seals between the pneumatic drive system and the rinse chamber. The packing sleeve contains three radial seals. Additionally the packing sleeve improves the guidance of the sensor.

For both sides of the ball valve are scrapers optionally available (pos. 3 + 4).



Caution!

When the assembly is in the service position and the ball valve is open, the process pressure acts on the rinse connections. Therefore the rinse connections must be equipped with inlet and outlet safety seal.

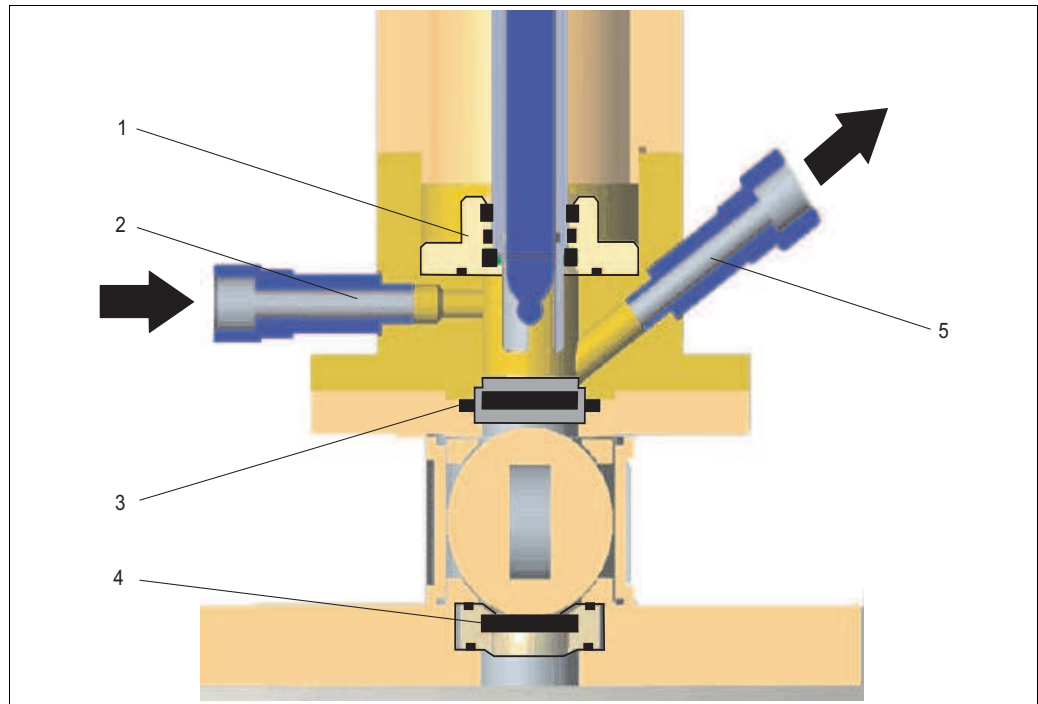

Fig. 7: Sealing system

- 1 Packing sleeve (made of PEEK) with 3 seals
- 2 Rinse inlet
- 3 Scraper PVDF
- 4 Scraper PEEK with O-rings
- 5 Rinse outlet with manual or pneumatic outlet safety seal

### 3.2.6 Sealing-water function

For the sealing-water function the assembly must be equipped with a pneumatic outlet safety seal for rinse chamber outlet (see chapter "Accessories").

For sealing water the scraper no. 3 (above the ball valve) can be removed if needed.

### 3.2.7 Scraper function

The scraper rings are especially recommended in the following cases:

- If the rinse chamber, otherwise open to the process, should be protected during operation.
- If material sticking to the electrode holder (caused by the medium) should be scraped off when moving to service mode.

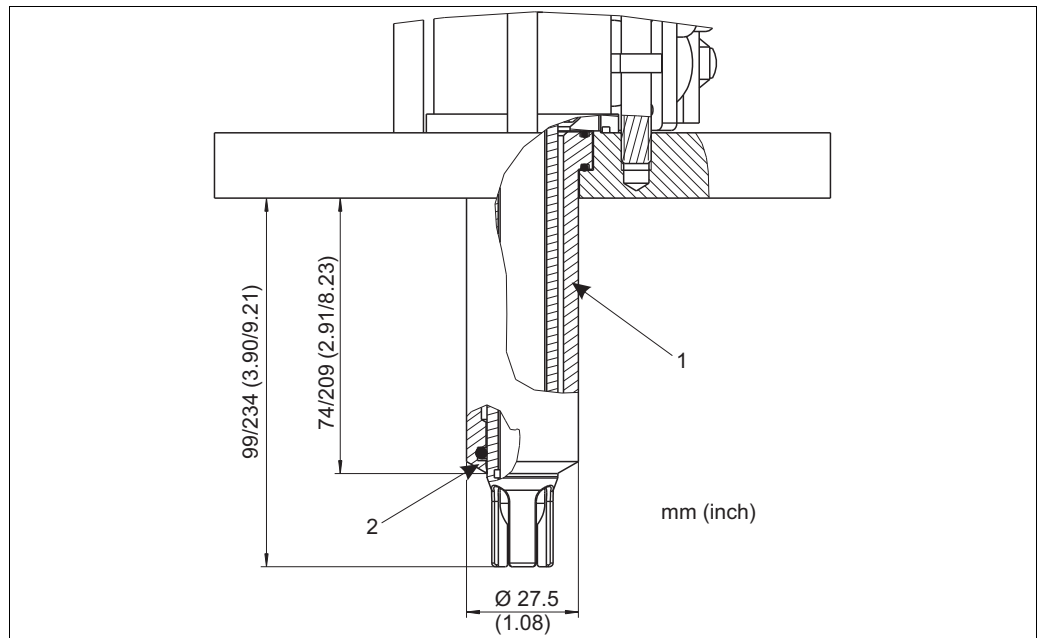

Fig. 8: Packing sleeve (short/long immersion depth)

- 1 Sleeve  
2 Scraper

### 3.3 Measuring system

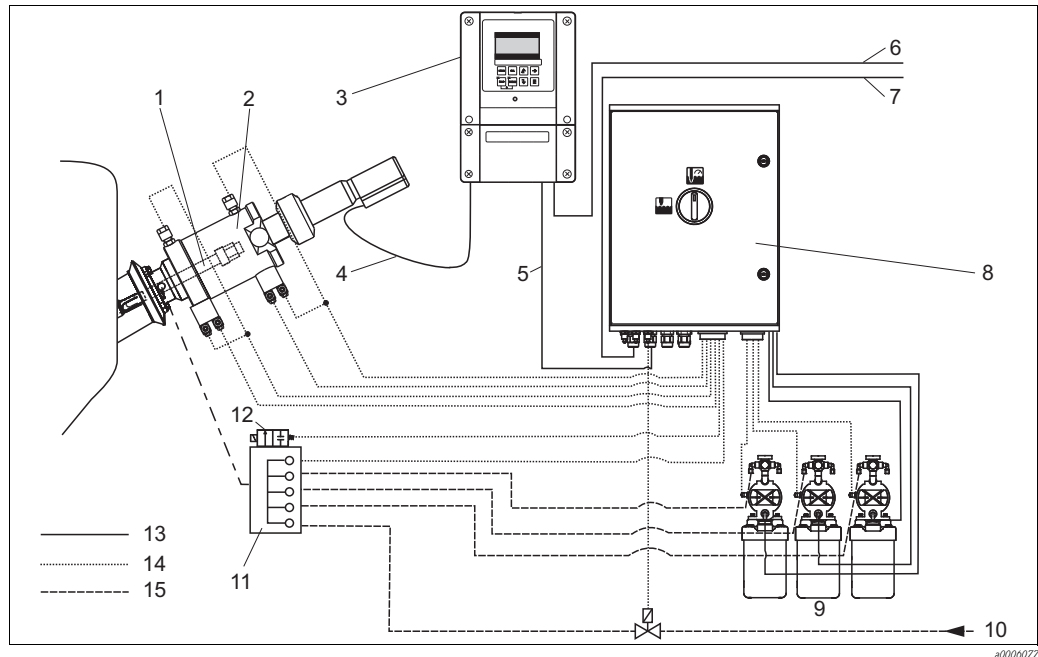

Fig. 9: Measuring system with pneumatic control

- |   |                                    |    |   |
|---|------------------------------------|----|---|
| 1 | pH/ORP sensor                      | 9  | Canisters for cleaning and buffer solutions           |
| 2 | Assembly Cleanfit                  | 10 | Superheated steam/water/cleaning solutions (optional) |
| 3 | Transmitter Mycom S CPM153         | 11 | Rinse block   |
| 4 | Special measuring cable            | 12 | Rinse water valve                                     |
| 5 | Communication / power supply cable | 13 | Power/signal cables                                   |
| 6 | Power supply Mycom                 | 14 | Air hoses   |
| 7 | Power supply CPG310                | 15 | Media   |
| 8 | Control unit CPG310                |    |   |

### 3.4 Installing the assembly into the process



Note!

Depending on the process connection, please observe the following:

- Check the flange seal between the flanges before installing the assembly.
  - The thread adapter nut of thread G 1 ¼ does not function as a seal. Therefore, simply tighten the thread adapter nut by hand.
1. Move the assembly into the "Service" position (electrode holder inserted in the assembly).
  2. Secure the assembly to the tank or the piping using your selected process connection.
  3. Follow the instructions for compressed air and rinse water connection (if used) given in the following chapters.

### 3.5 Compressed air connection

Requirements:

- air pressure of 4 to 6 bar (60 to 90 psi)
- air must be filtered (40 µm) and be free of water and oil
- no continuous air consumption
- minimum nominal diameter of the air lines: 4 mm (0.16 inches).



Caution!

There must be a pressure-reducing valve upstream if the air pressure can increase to above 6 bar (90 psi) (including any short pressure surges).

We recommend you also use a pneumatic throttle for lower pressures. This results in a smoother assembly operation. Endress+Hauser offers such a throttle as an accessory (see chapter "Accessories").

#### 3.5.1 Limit position switches

The pneumatic limit position switches serve as control elements and determine the sequence of the individual steps.

The following types of limit position switches are available depending on the order version (product structure, "Assembly operation, ball valve"):

- "Pneumatic limit position switch" version: 4 pneumatic switches
- "Electric limit position switch" version: 3 pneumatic and 2 inductive switches

Pneumatic: 3/2 way valve; thread M 12 x 1;  
connection for hoses with OD = 6 mm (0.24")

Electric: inductive (NAMUR type); cable length: 10 m (32.8 ft);  
housing material: stainless steel; thread M 12 x 1;  
nominal voltage: 8 V  
ⓈII 1G EEx ia IIC T6; switching distance: 2 mm, flush

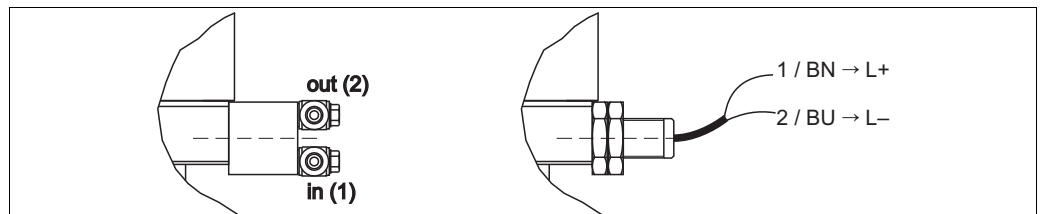

Fig. 10: Limit position switches, left: pneumatic (1 = compressed air inlet, 2 = compressed air outlet) right: electric (NAMUR)



Note!

The position of the input resp. the output may be different from the figure. Please, refer to the marks at the limit position switch: "1" is the input (in), "2" is the output (out).

### 3.5.2 Connections



Note!

The assembly is delivered completely hosed-up.

All you have to do is connect the compressed air for pneumatic operation of the ball valve and the outputs for pneumatic feedback signals to the pneumatic terminal block.

1. Please, refer to the sticker on the pneumatic terminal block to connect the compressed air hoses (Fig. 11).
2. Plug the compressed air hoses into the corresponding fittings. Refer also to the identical numbers engraved directly on the corresponding input (resp. output) on the terminal block (Fig. 12).

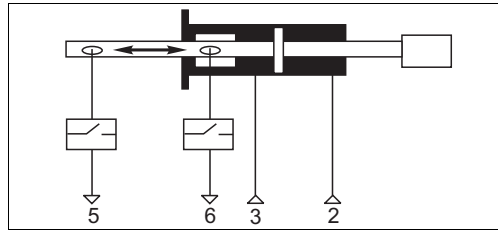

Fig. 11: Pneumatic terminal block sticker  
 2 Compressed air input "Start Measuring" (Pneumatics "Open ball valve")  
 3 Compressed air input "Start Service" (Pneumatics "Close ball valve")

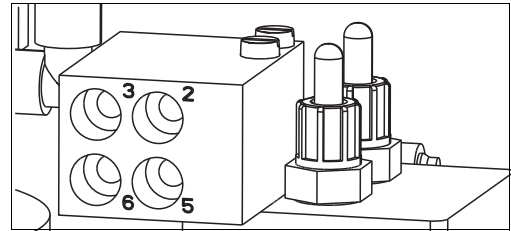

Fig. 12: Pneumatic terminal block  
 5 Feedback signal "Assembly Measuring" (Limit position switch "Ball valve open")  
 6 Feedback signal "Assembly Service" (Limit position switch "Ball valve closed")

Assembly version with pneumatic limit position switches

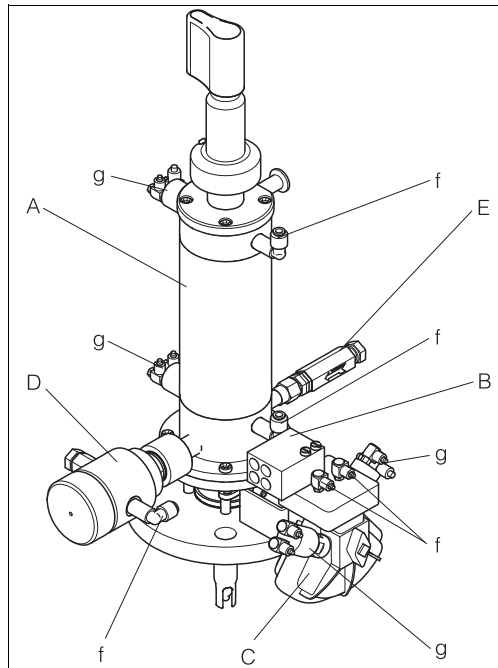

Fig. 13: Overview  
 A Assembly cylinder  
 B Pneumatic connection block  
 C Ball valve drive  
 D Pneumatic outlet safety seal (optional)

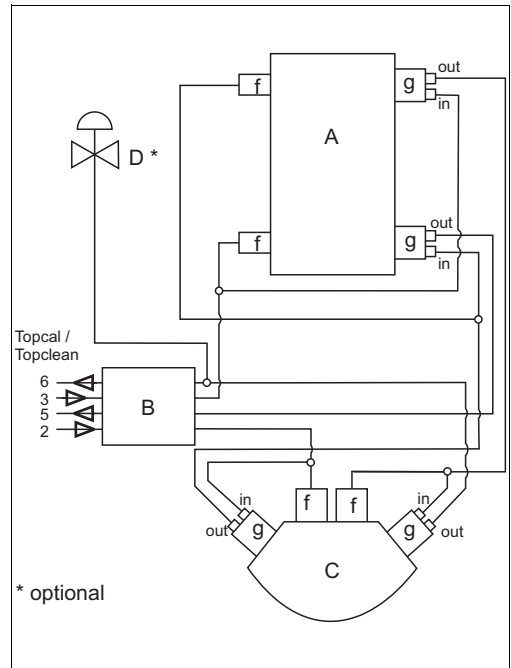

Fig. 14: Hosing  
 E Check valve (inlet safety seal, optional)  
 f Pneumatic fitting G1/8  
 g Pneumatic limit position switches



Assembly version with electrical limit position switches

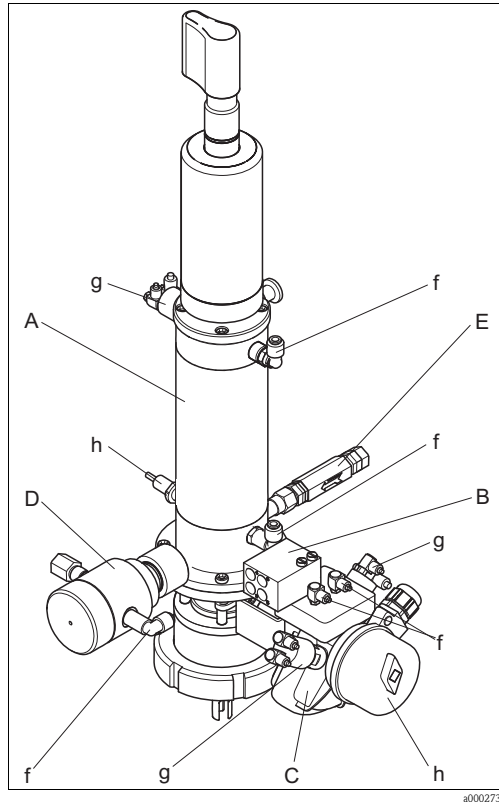

Fig. 15: Overview

- A Assembly cylinder
- B Pneumatic connection block
- C Ball valve drive
- D Pneumatic outlet safety seal (optional)

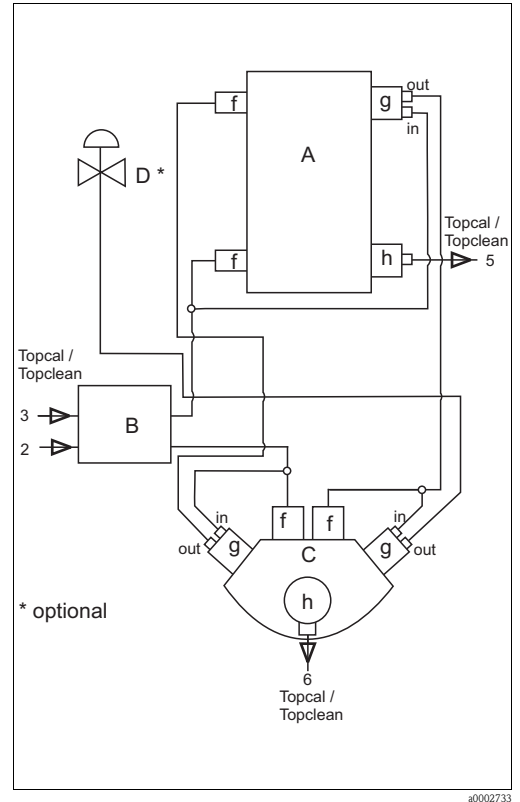

Fig. 16: Hosing

- E Check valve (inlet safety seal, optional)
- f Pneumatic fitting G1/8
- g Pneumatic limit position switches
- h Electrical limit position switches

### 3.6 Rinse water connection

1. Connect the rinse water pipe to the designated rinse nozzle. Both rinse nozzles on the assembly are identical. Use one as an inlet and the other as an outlet.
2. Operate the rinse water connection of the assembly with a water pressure of 2 to max. 6 bar (29 to 87 psi).
3. In addition, install a non-return valve and a dirt trap (100 µm) in the water supply line (at the inlet to the assembly).

Besides water, other or additional cleaning solutions may be used in the rinse chamber. Pay attention to the material resistance of the assembly and comply with the maximum permitted temperatures and pressures.



**Caution!**

If it is possible for the water pressure to rise above 6 bar (87 psi, including any transient pressure surges), install a pressure reducing valve upstream. Otherwise the assembly may be damaged.

### 3.6.1 Optional inlet and outlet safety seals

Optionally the assembly is supplied with a non-return valve on the inlet side of the rinse chamber (inlet safety seal) and an outlet valve (pneumatic outlet safety seal) resp. a ball valve (manual outlet safety seal, see product structure).

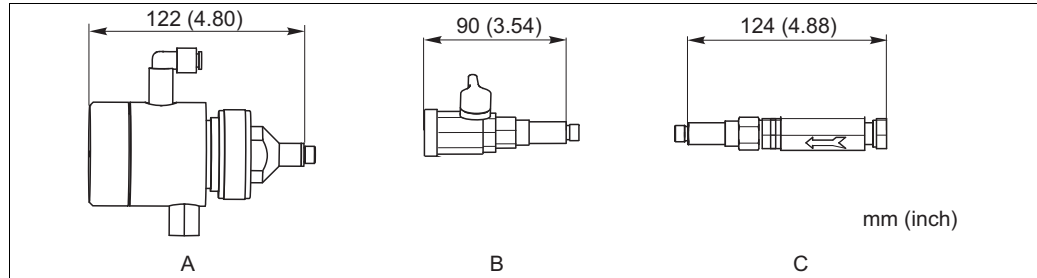

Fig. 17: Inlet / outlet safety seals for rinse chamber

- A Pneumatic outlet safety seal
- B Manual outlet safety seal (plastic version)
- C Non-return valve (inlet safety seal)

A manual outlet safety seal (stainless steel) is available as accessory.



Caution!

An outlet safety seal is definitely required if the rinse chamber does not remain sealed with the drain plug<sup>2)</sup>.

#### Inlet safety seal

The non-return valve prevents medium from penetrating from the rinse chamber into the rinse water inlet.

#### Manual outlet safety seal

The manual safety seal is a ball valve made of PVDF. You have to drive it manually.

#### Pneumatic outlet safety seal

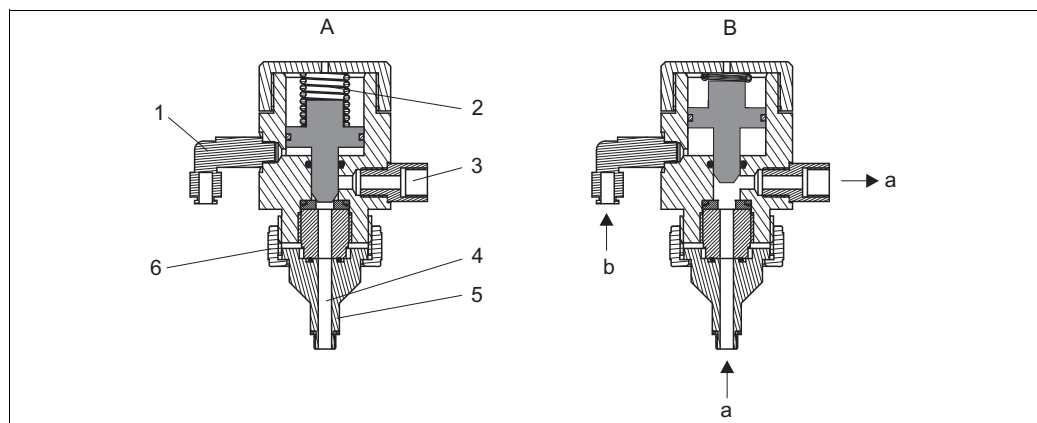

Fig. 18: Functional diagram of the pneumatic valve on the outlet side of the rinse chamber

A: Valve closed (no connection between rinse water and rinse chamber)

B: Valve open (rinse water can enter rinse chamber)

- |                                 |                           |
|---------------------------------|---------------------------|
| 1 Compressed air input          | 5 Rinse connection socket |
| 2 Compression spring            | 6 Union nut G 1/4         |
| 3 Rinse water outlet            | a Rinse water             |
| 4 Outlet from the rinse chamber | b Compressed air          |

2) also applies in "Measure" position

*Installation of the pneumatic outlet safety seal***Note!**

When ordering an assembly with pneumatic outlet safety seal, you get this seal separately, not installed into the assembly.

1. Unscrew the dummy plug from the rinse chamber outlet.
2. Mount the delivered pneumatic outlet safety seal (Fig. 19).
3. Cut the following compressed air hose (see Fig. 14, Fig. 16):  
from pneumatic connection block, input 6 to the corresponding pneumatic limit position switch on the ball valve drive.
4. Connect each end of the cut hose to the delivered Y-piece.
5. Connect the third fitting of the Y-piece to the compressed air connector of the outlet safety seal (Fig. 19, pos. 2).
6. Connect the rinse water outlet hose to the valve connector (pos. 1, G $\frac{1}{4}$  or NPT  $\frac{1}{4}$ ", depending . to ordered version).

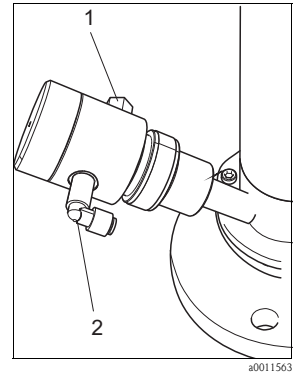

Fig. 19: Outlet safety seal

- 1 Rinse water outlet  
2 Compressed air

## 3.7 Sensor installation

### 3.7.1 Preparing sensor and assembly

1. Remove the protection cap from the sensor. Make sure the sensor shaft is fitted with the O-ring and the thrust collar (Fig. 20).
2. Moisten the sensor shaft before installing the sensor.
3. Depending on the assembly version:
  - a. *Manually driven assembly:*  
Pull the retractable pipe as far as possible out of the assembly.
  - b. *Pneumatically driven assembly:*  
Move the assembly into the "Service" position.
4. Turn the stop lock bolt through 90° so that the plastic grooves are located above the recesses (Fig. 21, A).
5. Turn the retractable pipe **clockwise** until the stop lock bolt engages (B).
6. *Manually driven assembly:*  
**Close the ball valve!**

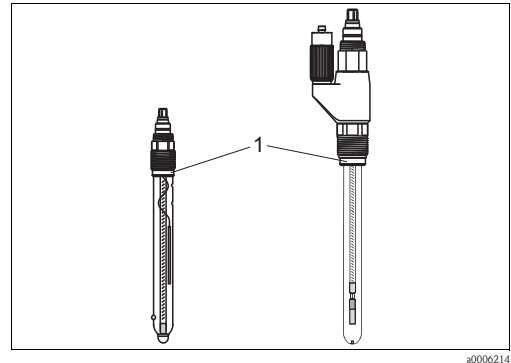

Fig. 20: Sensor installation

1 Thrust collar with O-ring

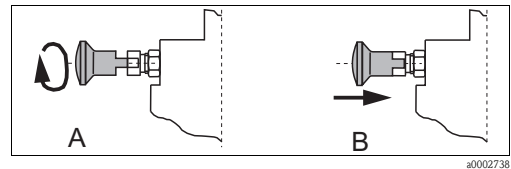



Fig. 21: Stop bolt



Caution!

If turned in the opposite direction, the stop lock bolt does not engage. This could, however, loosen the sensor holder. The reason for this is adhesions on the lower part of the sensor holder. These can cause the sensor holder to get stuck, producing a counterforce when unscrewing the sensor holder.

### 3.7.2 Gel sensor installation

1. Remove the splash protection cap (→  22, pos. 5) from the assembly.
2. Then loosen the retractable pipe (pos. 2) by turning it anticlockwise.
3. Install the sensor (pos. 7) instead of the dummy plug (pos. 3):
  - first screw by hand
  - then tighten the sensor by approx. ¼ turn using an open end wrench (AF 17).
4. Insert the measuring cable through the retractable pipe (pos. 2):
  - Fixed cable: from the bottom through the retractable pipe, from the sensor to the transmitter
  - Plug-in head sensor: from the top to the sensor head
5. *Plug-in head sensor only:* Connect sensor and cable.
6. Screw the retractable pipe back onto the pressure cylinder (clockwise, by hand).
7. Place the measuring cable in the splash protection cap and place the cap on the retractable pipe.
8. Unlock the stop lock bolt (pos. 4).

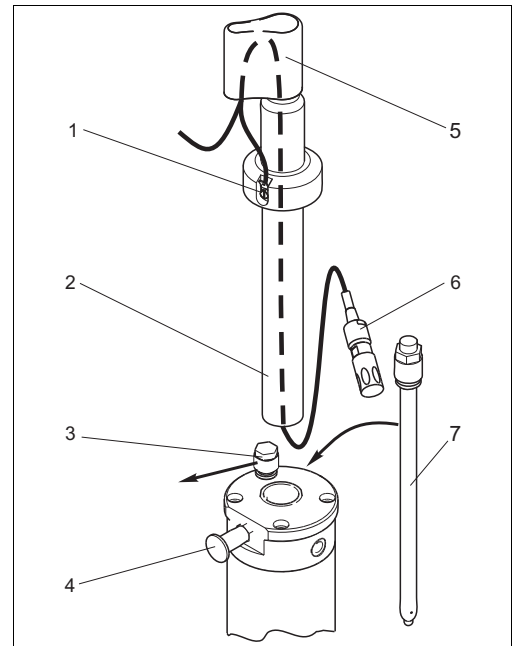

Fig. 22: Sensor installation

- |   |                                 |
|---|---------------------------------|
| 1 | PML connection                  |
| 2 | Retractable pipe                |
| 3 | Dummy plug                      |
| 4 | Stop lock bolt                  |
| 5 | Splash protection cap           |
| 6 | Measuring cable with cable plug |
| 7 | Sensor or electrode             |

Remove the sensor in the reverse sequence of operations.



Note!

In case of symmetrical pH measurement, you must push the PML connector onto the PML connection (PML = potential matching line, position 1). Please, read the Operating Instructions of the transmitter.

### 3.7.3 Sensor with liquid KCl electrolyte

1. Verify that the assembly is in the service position and the ball valve is closed.
2. Remove the splash protection cap (→  23, pos. 6) and the KCl hood (pos. 7).

 **Note!**

From version 11/2009 on the retractable pipe stays in the cylinder head.

3. Screw in the sensor directly into the inner thread of the retractable pipe:
  - first screw by hand
  - then tighten the sensor by approx. ¼ turn using an open end wrench (AF 17).
4. Insert the measuring cable through the protective tube and the KCl hood:
  - Fixed cable: from the sensor upwards to the transmitter
  - Sensor with plug-in head: from the top through the KCl hood to the sensor
  - In case of symmetrical pH measurement, you must push the PML connector onto the PML connection (PML = potential matching line, pos. 3).
5. *Plug-in head sensor only:* Connect sensor and cable.
6. Connect the electrolyte supply tube (pos. 1) to the electrolyte connection of the sensor.
7. Affix the supplied tubing support (pos. 9) to the electrolyte supply tube directly above the electrolyte connection.
8. Attach the KCl hood to the retractable pipe. Guide the electrolyte supply tube through the lateral slot of the hood.
9. Place the measuring cable in the splash protection cap and place the cap on the KCl hood.
10. Unlock the stop lock bolt (pos. 5).

Remove the sensor in the reverse sequence of operations.

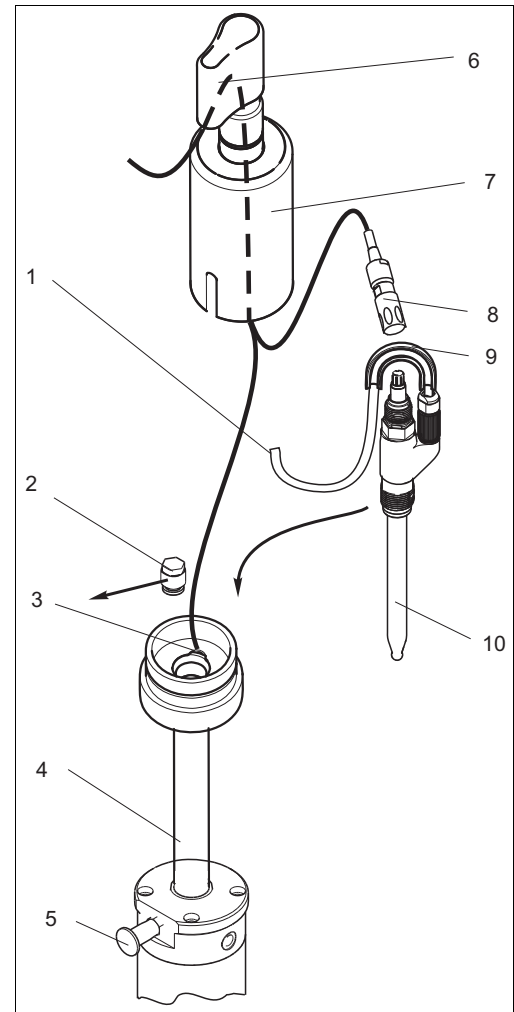

Fig. 23: Liquid KCl electrolyte sensor installation

- 1 Liquid KCl supply tube
- 2 Dummy plug
- 3 PML connection
- 4 Retractable pipe
- 5 Stop lock bolt
- 6 Splash protection cap
- 7 KCl hood
- 8 Plug-in head cable
- 9 Tubing support
- 10 Sensor with liquid KCl connection

### 3.8 Post-installation check

- After installation, check that all connections are firmly in position and leak-tight.
- Ensure that the hoses cannot be removed without force.
- Check all hoses for damage.

## 4 Operation

### 4.1 First commissioning

Before the first commissioning, make sure of the following items:

- All seals are correctly seated (on the assembly and process connection).
- The sensor is correctly installed and connected.
- The water supply line is correctly connected to the rinse connections (if fitted).
- The limit position switches (according to assembly version) are correctly connected.





Warning!

Danger of squirting medium.

Make sure the connections are correctly fitted with either rinsing hoses or dummy plugs before applying compressed air to the pneumatic assembly. Otherwise the assembly may **not** be put into the process!

### 4.2 Operating elements

Use the stop lock bolt to lock or release the retractable pipe (→  24, →  25).

When using manually operated assemblies, the retractable pipe can be locked in both, the "Measuring" position and the "Service" position. When using pneumatically operated assemblies, this can only be done in the "Service" position.

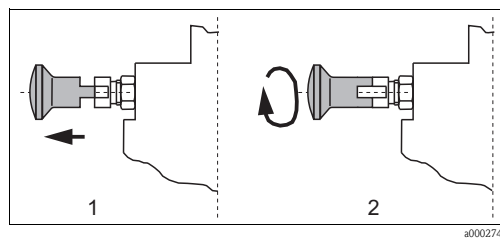

Fig. 24: Releasing the stop lock bolt

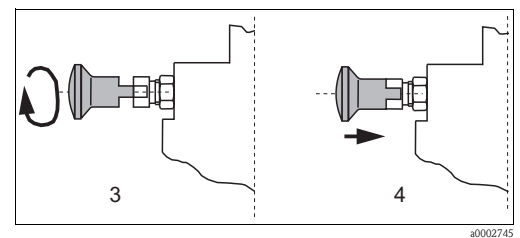

Fig. 25: Locking the stop lock bolt

Releasing the stop lock bolt:

1. Pull the bolt out.
2. Turn the bolt by 90° so that the plastic grooves rest on the metal edge.

Locking the stop lock bolt:

3. Turn the stop lock bolt through 90° so that the plastic grooves are located above the recesses.
4. When the retractable pipe is turned clockwise, the bolt engages.

### 4.3 Manual operation

**Moving the assembly from the "Service" position to the "Measuring" position**

1. Open the ball valve.
2. Release the stop lock bolt catch.
3. Push the lifting tube so that the sensor holder is inserted fully into the process.
4. Lock the sensor holder with the stop lock bolt. This prevents the lifting tube from returning inadvertently into the "Service" position.



Warning!

Risk of injury!

Always lock the sensor holder. Otherwise, the lifting tube may exit uncontrolled as a result of the process pressure and injure somebody.

**Moving the assembly from the "Measuring" position to the "Service" position**

1. Release the stop lock bolt catch.
2. Pull the lifting tube out as far as possible ("Service" position).
3. Close the ball valve.
4. Lock the sensor holder with the stop lock bolt.
5. Complete the necessary service tasks.

**4.4 Pneumatic operation**

**4.4.1 Connections and limit position switches overview**

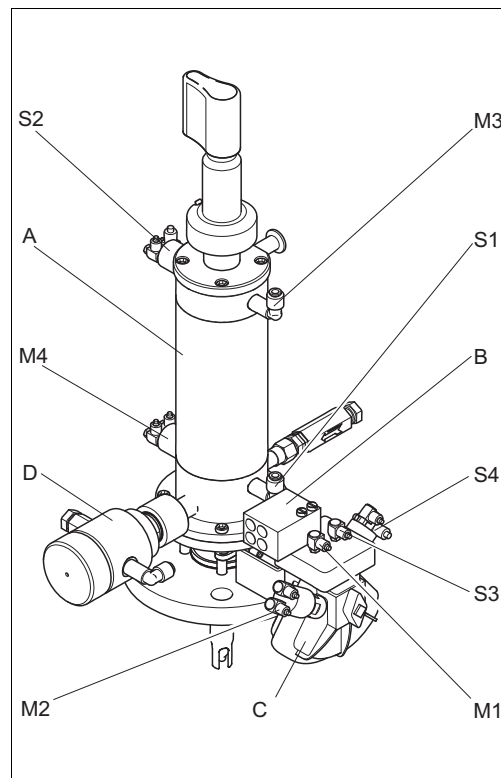

Fig. 26: Pneumatic limit position switches

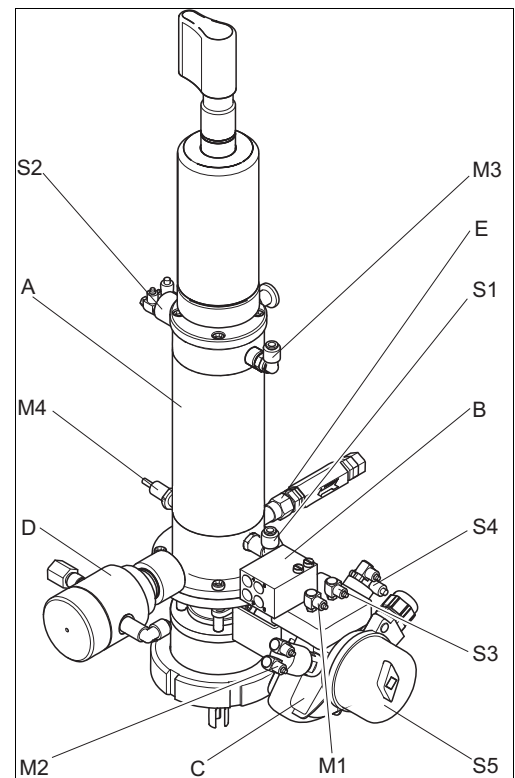

Fig. 27: Electrical limit position switches

- A Assembly cylinder
- B Pneumatic connection block
- C Ball valve drive

- Measuring:**
- M1 Pneumatics "Open ball valve"
  - M2 Limit position switch "Ball valve open"
  - M3 Pneumatics "Assembly Measuring"
  - M4 Limit position switch "Assembly Measuring"

- D Rinsing input / output
- E Rinse inlet with non-return valve

- Service:**
- S1 Pneumatics "Assembly Service"
  - S2 Limit position switch "Assembly Service"
  - S3 Pneumatics "Close ball valve"
  - S4 Limit position switch (pneu.) "Ball valve closed"
  - S5 Limit position switch (el.) "Ball valve closed"



**Note!**

The following chapters describe the **principle** of assembly moving. The figures show **only the details necessary** to explain this principle.

Please, refer to the chapter "Installation" / "Installation instructions" and the figures there for assembly hosing and installation into the process!



#### 4.4.2 Indication of the ball-valve position

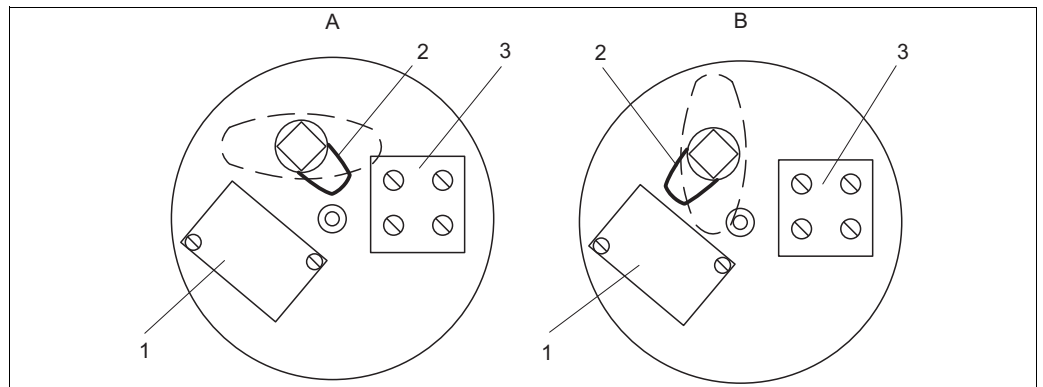

Fig. 28: Indication of the ball valve position

- A Ball valve is closed (cam points to the terminal)  
 B Ball valve is open (cam points to the proximity switch)  
 1 Proximity switch  
 2 Cam  
 3 Terminal

The position of the ball valve is indicated in the following way:

- The cam points to the terminal - ball valve is closed  
 The cam **has no** influence to the inductive field of the proximity switch. The resulting voltage is undamped.
- The cam points to the proximity switch - ball valve is open  
 The cam **has** influence to the inductive field of the proximity switch. The resulting voltage is damped.

### 4.4.3 Moving from "Service" position into "Measuring" position

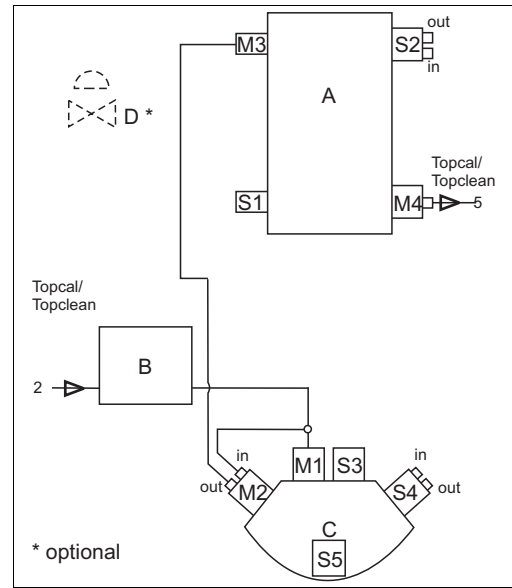
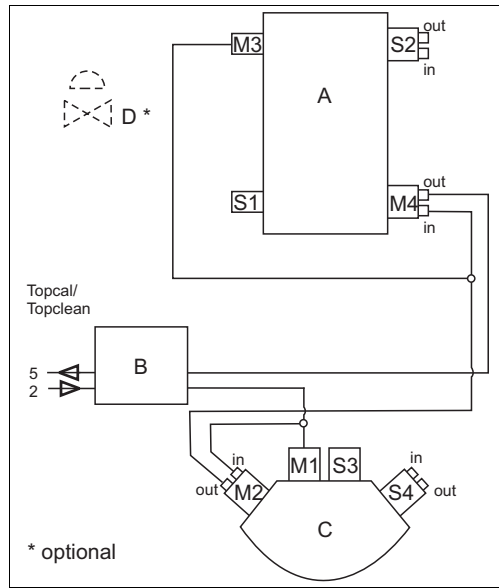

Fig. 29: Move to "Measuring" position, version with pneumatic limit position switches

Fig. 30: Move to "Measuring" position, version with electric limit position switches

in Pneumatic input, limit position switch  
 out Pneumatic output, limit position switch  
 5 Feedback signal "Assembly measuring"  
 2 Compressed air input "Start measuring"

A Assembly cylinder  
 B Pneumatics connection block  
 C Ball valve drive  
 D Outlet safety seal for rinse chamber

1. Compressed air is provided at position M1 (pneumatic "Open ball valve"). At the same time, compressed air is applied to M2 (limit position switch "Ball valve open"). The ball valve (C) opens. **The rinse chamber outlet valve (D) must be closed.**
2. When the ball valve is completely open, the limit position switch M2 forwards compressed air to the pneumatics of the pressure cylinder, input "Assembly measuring" (M3) and simultaneously to the limit position switch "Assembly measuring" (M4). The electrode holder moves out of the assembly into the medium.
3. Once the limit position is reached, the limit position switch M4 sends a signal (5, "Assembly measuring" feedback signal) to the transmitter / DCS or to Topcal S / Topclean S.

### 4.4.4 Moving from "Measuring" position into "Service" position

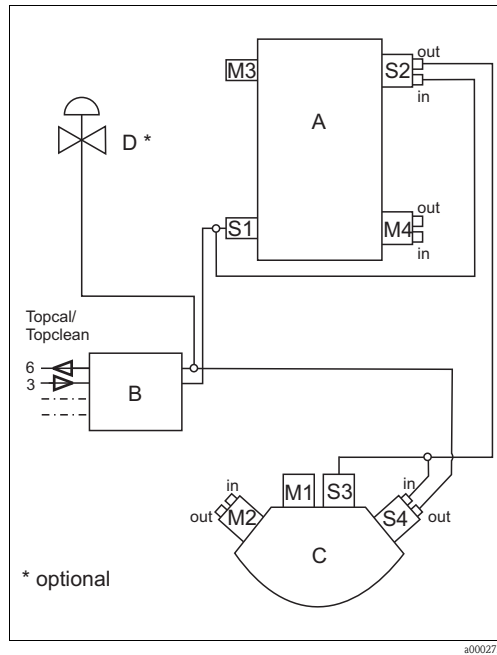

Fig. 31: Move to "Service" position, version with pneumatic limit position switches

in Pneumatic input, limit position switch  
 out Pneumatic output, limit position switch  
 6 Feedback signal "Assembly service"  
 3 Compressed air input "Start service"

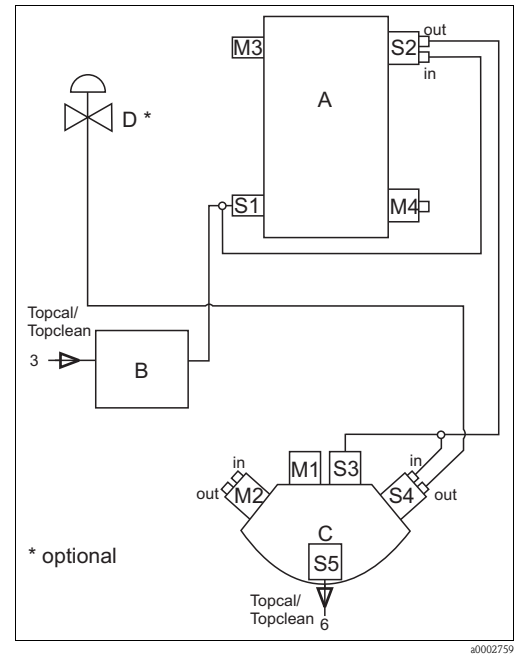

Fig. 32: Move to "Service" position, version with electric limit position switches

A Assembly cylinder  
 B Pneumatics connection block  
 C Ball valve drive  
 D Outlet safety seal for rinse chamber

1. Compressed air is simultaneously provided at the pneumatics of the pressure cylinder, input "Assembly service" (S1) and at the limit position switch "Assembly service" (S2). The electrode holder moves from the medium into the assembly.
2. When the limit position is reached, the limit position switch S2 forwards pressure to position S3 (close ball valve) and position S4 (limit position switch "Ball valve closed") simultaneously. The ball valve (C) closes.
3. Once the ball valve is completely closed, a signal (6, "Assembly service" feedback signal) is sent from the limit position switch S4 (or the limit position switch S5 in case of the version with electric limit position switches) to the transmitter / DCS or to Topcal S / Topclean S. At the same time, pressure is applied to the rinse chamber outlet valve (D). Valve D opens as long as the pressure is applied. Any drop in pressure causes this valve to close.

## 5 Maintenance



Warning!

Risk of injury!

Before starting maintenance work on the assembly, make sure that the process line and the tank are depressurized, empty and rinsed.

Move the assembly to the "Service" position and lock the retractable pipe by the stop lock bolt.

### 5.1 Cleaning the assembly

To ensure a reliable measurement, the assembly and the sensor must be cleaned at regular intervals. The frequency and intensity of the cleaning operation depend on the process medium.

#### 5.1.1 Manually operated assembly

All parts in contact with the medium, e.g. the sensor and the sensor holder, must be cleaned at regular intervals. Remove the sensor<sup>3)</sup>.

- Remove light dirt using suitable cleaning agents (see chapter "Cleaning agents").
- Remove severe fouling with a soft brush and a suitable cleaning agent.
- Remove persistent fouling by soaking in a liquid cleaner and if necessary by cleaning with a soft brush.



Note!

A typical cleaning interval for e.g. drinking water is at least half a year.

#### 5.1.2 Pneumatically operated assembly

Pneumatically-controlled cleaning can be carried out regularly via the rinse connection and the corresponding equipment, e.g. with the fully automatic cleaning and calibration system Topcal S CPC310.

### 5.2 Cleaning the sensor

You have to clean the sensor:

- before every calibration
- regularly during operation
- before being returned to the supplier

You can remove and clean the sensor manually or perform an automatic cleaning operation<sup>4)</sup> via the rinse connection.



Note!

- Clean ORP electrodes only mechanically and with water, do not use any chemical cleaning agents. These cleaning agents apply a potential to the electrode that takes several hours to decay. This potential causes measuring errors.
- Do not use any abrasive cleaning agents. This can lead to irreparable damage of the sensor.
- After cleaning the sensor, rinse the rinse chamber of the assembly with copious amounts of water (possibly distilled or de-ionized). Otherwise, remaining residues of cleaning agent can corrupt measurement.
- If required, re-calibrate after cleaning.

3) in reverse sequence of operations to the installation procedure

4) with the corresponding assembly equipment only

### 5.3 Cleaning agents

The selection of the cleaning agent is dependent on the degree and type of contamination. The most common contaminations and the suitable cleaning agents are listed in the following table.

Type of contamination	Cleaning agent
Greases and oils	Hot water or tempered substances containing tensides (alkaline) <sup>1)</sup> or water-soluble organic solvents (e.g. ethanol)
Calciferous deposits, metal hydroxide deposits, lyophobic biological deposits	Approx. 3% hydrochloric acid
Sulphide deposits	Mixture of 3% hydrochloric acid and thiocarbamide (commercially available)
Protein deposits	Mixture of 3% hydrochloric acid and pepsin (commercially available)
Fibers, suspended substances	Water under pressure, poss. with surface-active agents
Light biological deposits	Water under pressure

1) do not use for Tophit ISFET sensors! Instead, use commercially available acidic cleaning agents for the food industry (e.g. P3-horolith CIP, P3-horolith FL, P3-oxonia active).



#### Caution!

Do not use organic solvents containing halogen or acetone. These solvents could destroy plastic components of the assembly or the sensor and are suspected carcinogens.

### 5.4 Notes on calibration

Regular sensor calibration is vital for reliable measurement. The calibration cycles depend on the range of application and the desired accuracy.

You have to define the calibration cycles separately for each application. At the start, perform calibration frequently (e.g. weekly) to determine the operating characteristics of the sensor. Follow the corresponding instructions for calibration in the Operating Instructions of the transmitter used.



#### Note!

- The calibration cycles depend on the process conditions and the medium.
- When using a symmetrical connection, there must be an electrical connection between the potential matching (PML) and the buffer solution.
- Do not allow a glass electrode to stand dry or pH sensors (including ISFET) to stand in distilled water.
- Do not use compressed air to blow clear automatic calibration systems with ISFET sensors.

## 5.5 Replacing seals

With closed ball valve you can replace the seals above the ball valve without interruption of the process.

To replace all seals of the assembly you have to interrupt the process and remove the assembly.



Warning!

Beware of medium residues and higher temperatures when handling components that were in contact with medium. Wear protection gloves and protection glasses.



Note!

Check the seals in contact with medium at least semi-annually.

Preparation:

1. Interrupt the process. Beware of medium residues, residual pressure and higher temperatures.
2. Move the assembly to the "Service" position. Secure this position by the stop lock bolt.
3. Dismount the sensor.
4. Dismount the assembly from the process connection.
5. Clean the assembly (see chapter "Cleaning the assembly")

**Dismantling the assembly:**

Illustration shows retractable pipe for gel sensors.

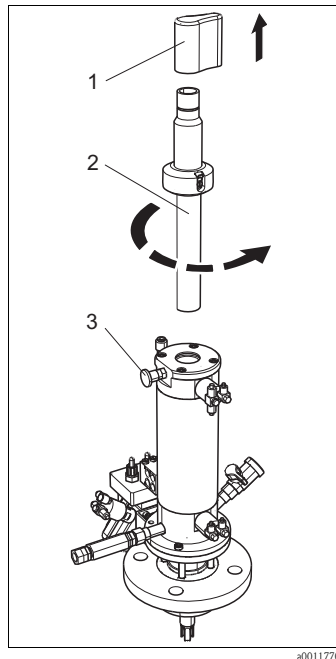

Fig. 33: Dismantling part 1

- 1 Splash protection cap
- 2 Retractable pipe
- 3 Stop lock bolt

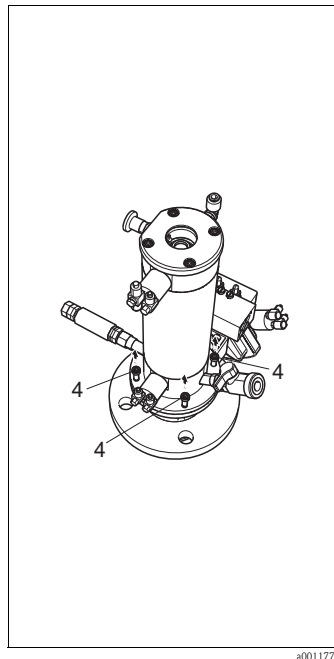

Fig. 34: Dismantling part 2

- 4 Connecting bolts (4 pcs.)

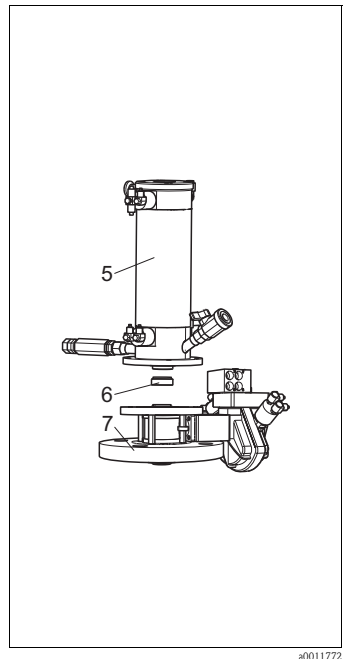

Fig. 35: Dismantling part 3

- 5 Pressure cylinder, cylinder head, rinse chamber
- 6 Scraper
- 7 Flange with ball valve

1. Pull off the splash protection cap (pos. 1).
2. Make sure the stop lock bolt (pos. 3) is locked.
3. Unscrew the retractable pipe (pos. 2) (not at KCl-sensors).
4. Loosen the four connecting bolts (pos. 4) at the top of the flange.
5. Remove the pressure cylinder and the rinse chamber (pos. 5).

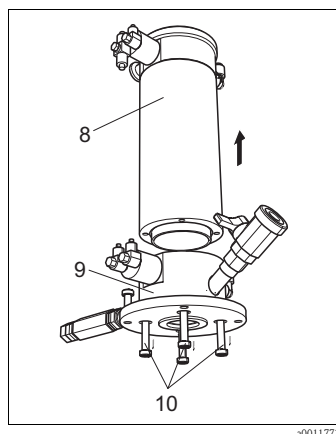

Fig. 36: Dismantling part 4

- 8 Pressure cylinder with cylinder head
- 9 Rinse chamber
- 10 Connecting bolts (4 pcs.) incl. 4 locking washers

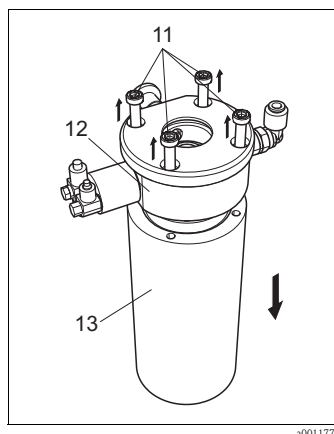

Fig. 37: Dismantling part 5

- 11 Connecting bolts (4 pcs.) with locking washers
- 12 Cylinder head
- 13 Pressure cylinder

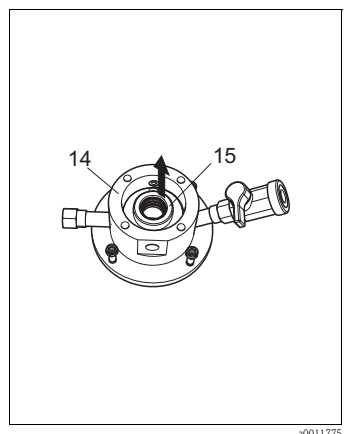

Fig. 38: Dismantling part 6

- 14 Rinse chamber
- 15 Sealing bushing

6. Loosen the four connecting bolts (pos. 10) at the bottom of the rinse chamber.
7. Remove the rinse chamber.
8. Loosen the four connecting bolts (pos. 11) at the cylinder head (pos. 12).
9. Remove the cylinder head.
10. Loosen the two connecting screws on the sealing bushing (pos. 15).

### Replacing the seals

1. Apply a thin layer of grease to the new seals (e.g. Syntheso Glep1).
2. Replace the seals as shown in Fig. 39.
3. Re-assemble the assembly.

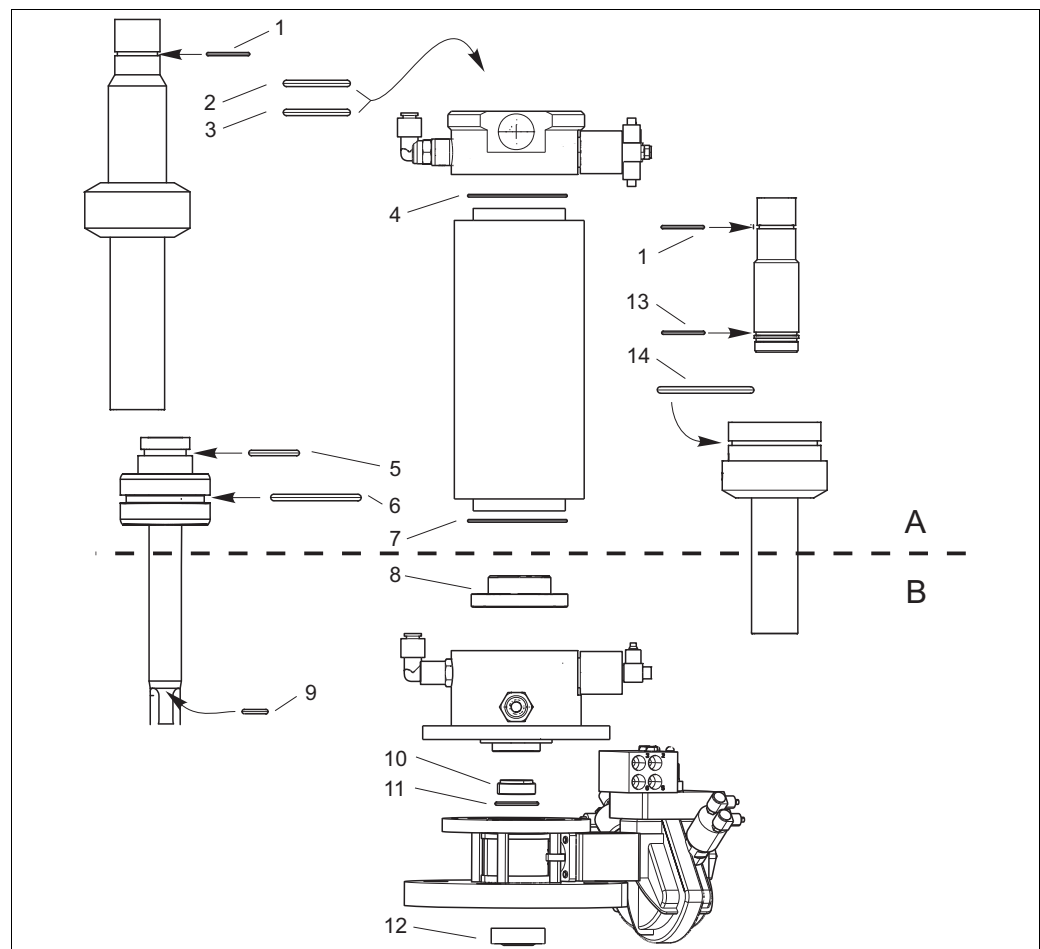

Fig. 39: Position of the seals

- A Seals, not in contact with medium  
 B Seals, in contact with medium  
 12 PEEK-scraper or protection sleeve (optional)



No	Kit-No.	Kit pos. No.	Size	Remarks/material
1	71064624	Pos. 60	ID 20.35 W1.78	EPDM
2	71064624	Pos. 20	ID 30.00 W3.50	Manual version, FPM
2+3	71064624	Pos. 20	ID 30.00 W3.50	Pneumatic version, FPM
4+7	71064624	Pos. 50	ID 52.00 W1.50	2x, EPDM
5	71064624	Pos. 10	ID 22.00 W3.00	EPDM
6	71064624	Pos. 30	ID 42.00 W4.00	Pneumatic version only, FPM
6	71064624	Pos. 40	ID 37.00 W4.00	Manual version only, FPM
8	71065938	Pos. 90	Bushing Variseal	With 2 O-rings and 2 moulded gaskets, KALREZ
8	71065937	Pos. 90	Bushing Variseal	With 2 O-rings and 2 moulded gaskets, FPM
8	71065935	Pos. 90	Bushing Variseal	With 2 O-rings and 2 moulded gaskets, EPDM
9	71065930	Pos. 10	ID 11.00 W2.00	KALREZ
9	71065929	Pos. 10	ID 11.00 W2.00	FPM
9	71065927	Pos. 10	ID 11.00 W2.00	EPDM
10	71065930	Pos. 80	Bushing	With scraper, KALREZ
10	71065929	Pos. 80	Bushing	With scraper, FPM
10	71065927	Pos. 80	Bushing	With scraper, EPDM
11	71065930	Pos. 30	ID 27.00 W3.00	KALREZ
11	71065929	Pos. 30	ID 27.00 W3.00	FPM
11	71065927	Pos. 30	ID 27.00 W3.00	EPDM
12	71065930	Pos. 20	Scraper PEEK *	With 3 O-rings, KALREZ
12	71065929	Pos. 20	Scraper PEEK *	With 3 O-rings, FPM
12	71065927	Pos. 20	Scraper PEEK *	With 3 O-rings, EPDM
13	71064624	Pos. 80	ID 23.52 W1.78	KCl version
14	71064624	Pos. 90	ID 55.25 W2.62	KCl version

\* The O-rings of the PEEK scraper can also be used on the PEEK protection sleeve.

## 6 Accessories

### 6.1 Process adapter

Built-in adapter DN 25

- Stainless steel 1.4404
- "Straight" version - Order No.: 51500328
- "Inclined" version - Order No.: 51500327

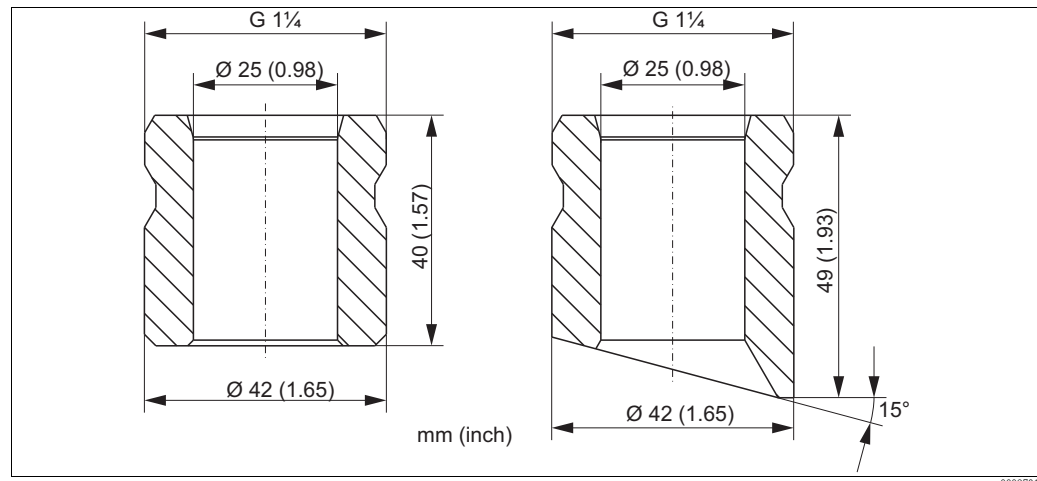

Fig. 40: G 1/4 built-in adapter, straight and inclined

Welded fitting DN 50 (70 mm), inclined, material: 1.4571 (AISI 316 Ti);

- order no. C-PA050801-20

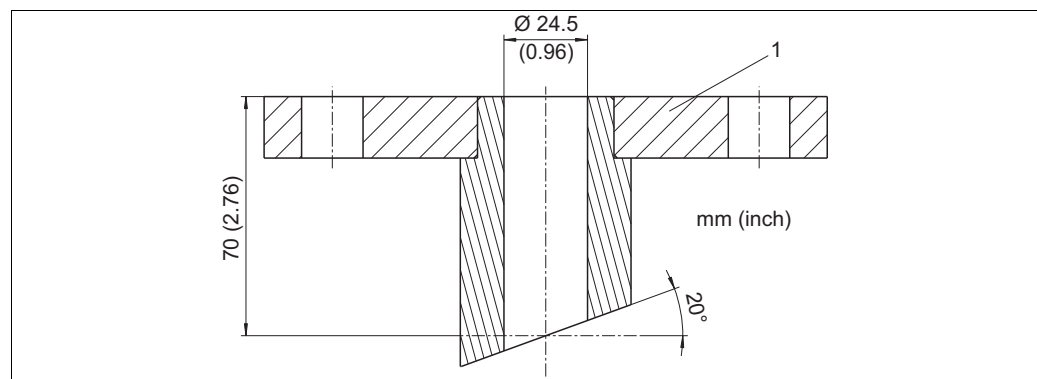

Fig. 41: Welded fitting

1 Flange DN 50 / PN16

### 6.2 Water filter and pressure reducer

Filter set CPC310

- Water filter (dirt trap) 100  $\mu\text{m}$ , complete, incl. angle bracket;
- Order no. 71031661

Pressure reducer kit

- Complete, incl. manometer and angle bracket;
- Order no. 51505755

Pneumatic throttle for the reduction of the assembly moving speed,

- G1/8 threaded connection
- order no. 50036864

### 6.3 Rinse connection adapter

- Rinse connection adapter CPR40 for connecting 2 or 4 different media.  
Order acc. to product structure, see Technical Information (TI342C/07/en).

### 6.4 Flow assembly

Flowfit CPA240

- Flow vessel for processes with advanced specifications
- Order acc. to product structure, see Technical Information TI179C/07/en

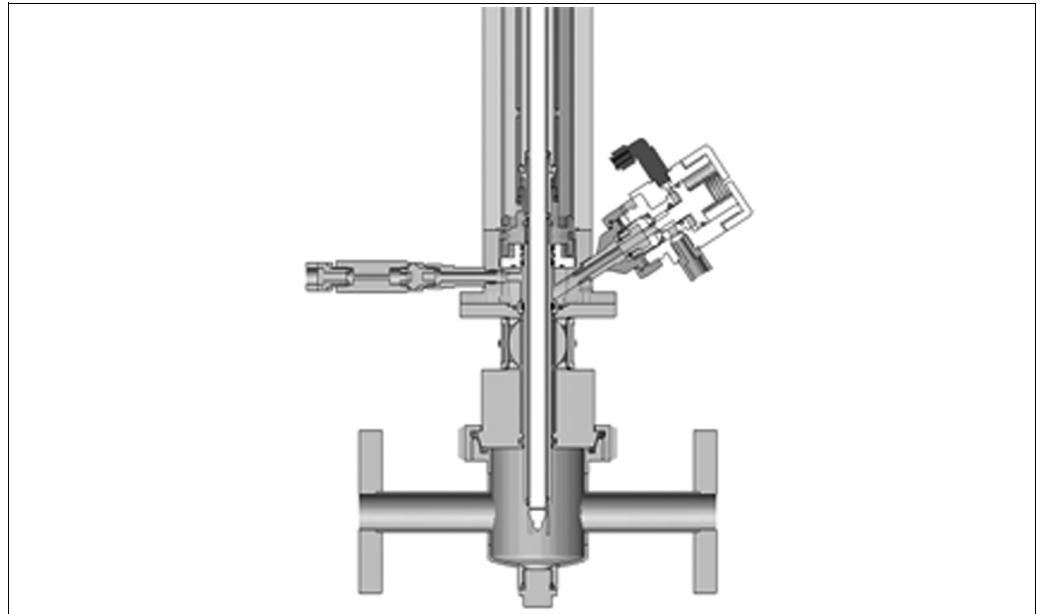

Fig. 42: CPA473 with process adapter dairy fitting DN65, measuring position in CPA240

### 6.5 Inlet and outlet safety seal

Pneumatic outlet safety seal for rinse chamber outlet

- G ¼", order no. 51511929
- NPT ¼", order no. 51511934

Manual outlet safety seal for rinse chamber outlet

- G ¼", order no. 51511937
- NPT ¼", order no. 51511938

Manual outlet safety seal for rinse chamber

- Ball valve, stainless steel 1.4408 (AISI CF-8M)
- G ¼", order no. 71083041

Non-return valve (inlet safety seal) for rinse chamber inlet

- G ¼", order no. 51511939
- NPT ¼", order no. 51511940

## 6.6 Hose connectors for rinse chamber

- Hose connection set,  
for Cleanfit assemblies, PVDF, G ¼, D12  
order no. 51511724
- Hose connection set,  
for Cleanfit assemblies, stainless steel 1.4404 (AISI 316L), NPT ¼", D12  
order no. 51511725
- Hose connection set,  
for Cleanfit assemblies, PVDF, NPT ¼", D12  
order no. 51511726
- Hose connection set,  
for Cleanfit assemblies, stainless steel 1.4404 (AISI 316L), NPT ¼", D16  
order no. 51511722
- Hose connection set,  
for Cleanfit assemblies, PVDF, NPT ¼", D16  
order no. 51511723
- Hose connection set,  
for Cleanfit assemblies, stainless steel 1.4404 (AISI 316L), G ¼, D16  
order no. 51511590
- Hose connection set,  
for Cleanfit assemblies, PVDF, G ¼, D16  
order no. 51511591

## 6.7 Limit position switches

Set of pneumatic limit position switches (2 pieces);

- order no. 51502874

Set of electric limit position switches, Ex and non-Ex (2 pieces);

- order no. 51502873

## 6.8 Retrofit kit

Retrofit kit

- Retrofit kit for manual to pneumatic operation of the retractable assembly
- order no.: 71041407

## 6.9 Sensors

### 6.9.1 Glass electrodes

Orbisint CPS11/CPS11D

- pH sensor for process applications
- Optionally with Memosens technology
- With PTFE diaphragm
- Ordering acc. to product structure, see Technical Information (TI028C/07/en)

Orbisint CPS12/CPS12D

- ORP electrode for process applications
- Optionally with Memosens technology
- With PTFE diaphragm
- Ordering acc. to product structure, see Technical Information (TI367C/07/en)

Ceraliquid CPS41/CPS41D

- pH sensor
- Optionally with Memosens technology
- With ceramics diaphragm and liquid KCl electrolyte
- Ordering acc. to product structure, see Technical Information (TI079C/07/en)

Ceraliquid CPS42/CPS42D

- ORP electrode
- Optionally with Memosens technology
- With ceramics diaphragm and liquid KCl electrolyte
- Ordering acc. to product structure, see Technical Information (TI373C/07/en)

Ceragel CPS71/CPS71D

- pH sensor
- Optionally with Memosens technology
- With double chamber reference system and integrated bridge electrolyte
- Ordering acc. to product structure, see Technical Information (TI245C/07/en)

Ceragel CPS72/CPS72D

- ORP electrode
- Optionally with Memosens technology
- With double chamber reference system and integrated bridge electrolyte
- Ordering acc. to product structure, see Technical Information (TI374C/07/en)

Orbipore CPS91/CPS91D

- pH sensor
- Optionally with Memosens technology
- With open aperture for media with high dirt load
- Ordering acc. to product structure, see Technical Information (TI375C/07/en)

### 6.9.2 ISFET sensors

Tophit CPS471/CPS471D

- Sterilizable and autoclavable ISFET sensor for food and pharmaceuticals, process technology, water treatment and biotechnology;
- Ordering acc. to product structure, see Technical Information (TI283C/07/en)

Tophit CPS441/CPS441D

- Sterilizable ISFET sensor for media with low conductivity, with liquid KCl electrolyte;
- Ordering acc. to product structure, see Technical Information (TI352C/07/en)

Tophit CPS491/CPS491D

- ISFET sensor with open aperture for media with high dirt load;
- Ordering acc. to product structure, see Technical Information (TI377C/07/en)

## 6.10 Transmitters

### Liquiline M CM42

- Modular two-wire transmitter, stainless steel or plastic, field or panel instrument
- Various Ex approvals (ATEX, FM, CSA, Nepsi, TIIS)
- HART, PROFIBUS or FOUNDATION Fieldbus available
- Ordering acc. to product structure, see Technical Information (TI381C/07/en)

### Liquisys M CPM223/253

- Transmitter for pH and ORP, field or panel-mounted housing
- HART or PROFIBUS available
- Ordering acc. to product structure, see Technical Information (TI194C/07/en)

### Mycom S CPM153

- Transmitter for pH and ORP, one or two channel version, Ex or non-Ex
- HART or PROFIBUS available
- Ordering acc. to product structure, see Technical Information (TI233C/07/en)

## 6.11 Measuring, cleaning and calibration systems

### Topcal S CPC310

- Fully automatic measuring, cleaning and calibration system; Ex or non-Ex
- In-situ cleaning and calibration, automatic sensor monitoring
- Ordering acc. to product structure, Technical Information TI404C/07/en

### Topclean S CPC30

- Fully automatic measuring and cleaning system; Ex or non-Ex
- In-situ cleaning, automatic sensor monitoring
- Ordering acc. to product structure, see Technical Information TI235C/07/en

## 7 Trouble-shooting

### 7.1 Replacing damaged parts



Warning!

Damage to the assembly which affects the pressure safety must **only** be repaired by authorized technical personnel.

After every repair and maintenance activity, suitable measures must be taken to test whether the assembly shows any signs of leaking. The assembly must then correspond to the specifications stated in the technical data.

Replace all other damaged components immediately. To order accessories and spare parts, please use the "Accessories" and "Spare parts" chapters or contact your local sales center.

### 7.2 Replacing parts without process interrupt

When the ball valve is closed ("Assembly service"), you can completely remove the assembly body and the rinse chamber and replace components. You don't have to interrupt the process for this.



Warning!

**Never** remove the assembly body when the process is running with an open ball valve ("Assembly measuring")! Also ensure that the ball valve cannot be opened automatically (pneumatic control). Otherwise, there is a risk of injury through escaping medium.

The manufacturer is not liable for damage caused by improper or non-designated use.

Beware of medium residues and higher temperatures when handling components that were in contact with medium. Wear protection gloves and protection glasses.

### 7.3 Replacing parts with process interrupt

If you have to repair the ball valve or to replace the scraper or the packing sleeve you have to switch off the process before and vent the pipes.



Warning!

Make sure no medium can spill out.

Risk of injury!

## 7.4 Spare part kits

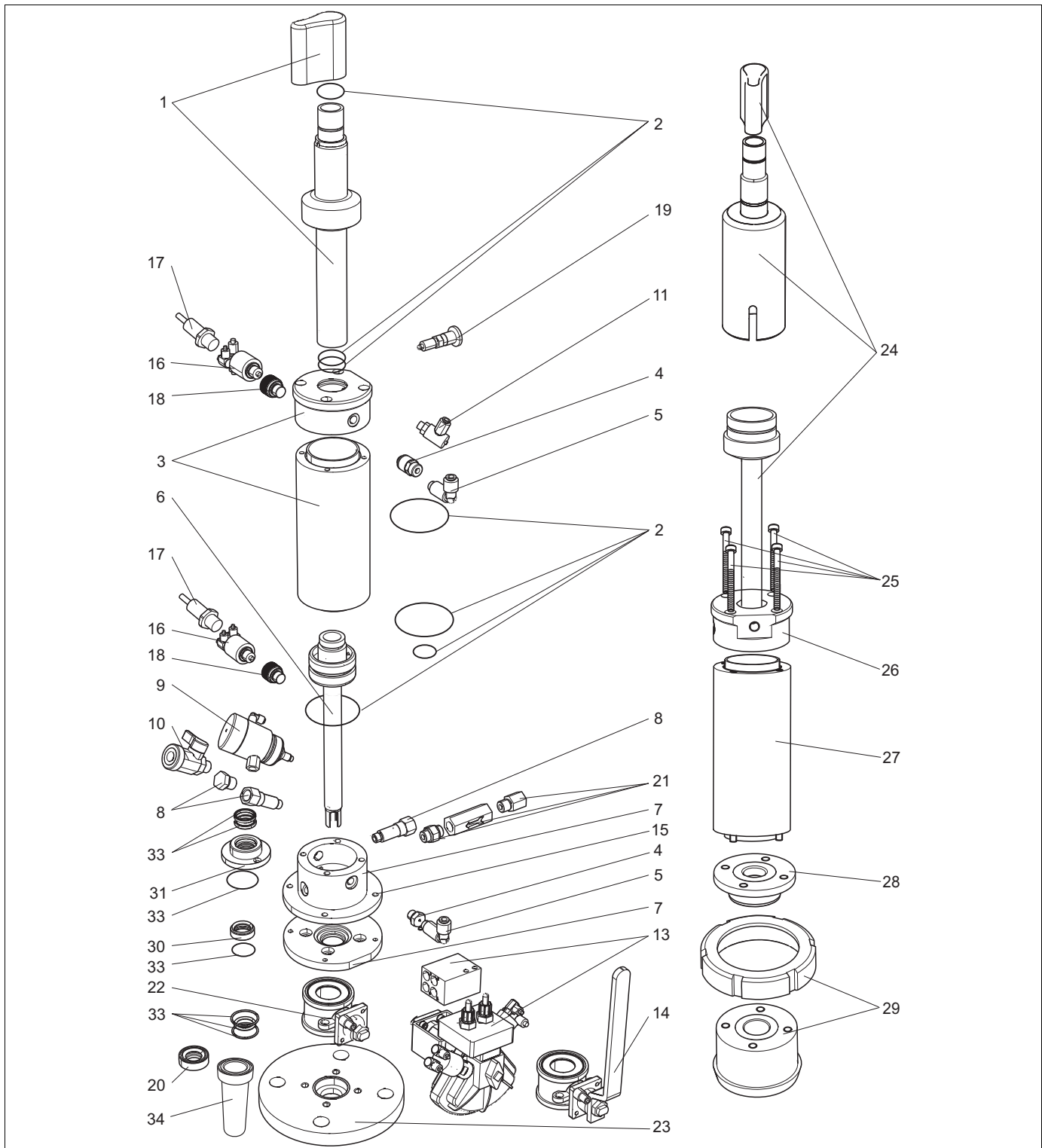

Fig. 43: Spare parts (all assembly versions)



**Note!**  
Please, refer to the following table for the spare part kits ordering numbers acc. to the positions in Fig. 43.



Position	Description and kit content	Spare part kit order no.
1	Retractable pipe for gel electrodes, length 225 mm (8.86") For assembly version: – pneumatic	51503716
	Retractable pipe for gel electrodes, length 225 mm (8.86") For assembly version: – manual	51503718
	Retractable pipe for gel electrodes, length 360 mm (14.17") For assembly version: – pneumatic	51513005
	Retractable pipe for gel electrodes, length 360 mm (14.17") For assembly version: – manual	51513006
2	Set of seals, not in contact with medium	71064624
3	PA cylinder, with O-rings, cylinder head and safety screw For assembly version: – short, immersion depth up to 100 mm (3.94")	51503774
	SS 1.4404 (AISI 316L) cylinder, with O-rings and cylinder head For assembly version: – short, immersion depth up to 100 mm (3.94")	51503776
4	Exhaust air restrictor and SS 1.4404 (AISI 316L) dummy plug For assembly version: – manual 5 pieces each	51503732
5	G1/8 pneumatic connections For assembly version: – pneumatic 10 pieces	51503730
6	Sensor guide, SS 1.4404 (AISI 316L), complete For assembly version: – short, immersion depth up to 100 mm (3.94")	51512677
	Sensor guide, SS 1.4404 (AISI 316L), complete For assembly version: – long, immersion depth up to 235 mm (9.25")	51512678
7	Rinse chamber complete, SS 1.4404 (AISI 316L) with packing sleeve (pos. 31) and sealing (Turcon Variseal / FPM)	51512689
8	Set of G $\frac{1}{4}$ rinse connectors, complete	51503771
	Set of NPT $\frac{1}{4}$ " rinse connectors, complete	51503772
9	Pneumatic outlet safety seal for G $\frac{1}{4}$ rinse chamber connections	51511929
	Pneumatic outlet safety seal for NPT $\frac{1}{4}$ " rinse chamber connections	51511934
10	Manual outlet safety seal for G $\frac{1}{4}$ rinse chamber connections	51511937
	Manual outlet safety seal for NPT $\frac{1}{4}$ " rinse chamber connections	51511938
11	Pneumatic throttle G1/8" to reduce the speed	50036864
13, 16	Pneumatic drive complete: Ball valve drive (pos. 13) + pneumatic terminal block (pos. 13), with pneumatic limit position switches incl. adapter	51512707
	Pneumatic drive complete: Ball valve drive (pos. 13) + pneumatic terminal block (pos. 13), with electric limit position switches (+ an additional pneumatic limit position switch at the ball valve drive)	51512708

Position	Description and kit content	Spare part kit order no.
14	Manual ball valve drive, 1.4404 (AISI 316L)	51512698
15	4 x cylinder head screws M6 x 60, DIN 6912, A4 with 4 retaining washers, 1 x cylinder head screw M5 x 235 with screw nut for plastic cylinder For assembly version: – CPA473/474 short	71106024
16	Set of pneumatic limit switches For assembly version: – pneumatic 2 pieces	51502874
17	Set of electric limit switches, Ex and Non-Ex For assembly version: – pneumatic 2 pieces	51502873
18	M12x1 stopper For assembly version: – pneumatic, without limit switch 10 pieces	51503733
19	Stop bolt	51503731
20	Scraper at ball valve; EPDM PEEK scraper in front and behind of the ball valve	71065932
	Scraper at ball valve; FPM PEEK scraper in front and behind of the ball valve	71065933
	Scraper at ball valve; KALREZ PEEK scraper in front and behind of the ball valve	71065934
21	Check valve (inlet safety seal) for G $\frac{1}{4}$ rinse chamber connection	51511939
	Check valve (inlet safety seal) for NPT $\frac{1}{4}$ " rinse chamber connection	51511940
22	Ball valve, without drive, SS 1.4404 (AISI 316L)	51512698
23	Flange DN 50 (DIN 1092-1), stainless steel 1.4404 (AISI 316L)	71065951
	Flange ANSI 2", stainless steel 1.4404 (AISI 316L)	71065952
24	Retractable pipe (from version 11/2009) for liquid KCl electrodes, length 425 mm (16.73"), incl. protective pipe, KCl hood and glue For assembly version: – pneumatic	71099157
	Retractable pipe (from version 11/2009) for liquid KCl electrodes, length 425 mm (16.73"), incl. protective pipe, KCl hood and glue For assembly version: – manual	71099159
25	M6x45 screws, DIN 69612 20 pieces	51503738
25-27	PA cylinder, with O-ring , cylinder head For assembly version: – long, immersion depth up to 235 mm (9.25")	71042130
	Cylinder stainless steel 1.4404 (AISI 316L) , with O-ring , cylinder head For assembly version: – long, immersion depth up to 235 mm (9.25")	71042134
28	G1 $\frac{1}{4}$ internal thread with thread adapter nut	on request
29	Dairy fitting DN 65 (DIN 11851)	on request
31	Packing sleeve Variseal, EPDM with PEEK adapter, complete	71065935
	Packing sleeve Variseal, FPM with PEEK adapter, complete	71065937
	Packing sleeve Variseal, KALREZ with PEEK adapter, complete	71065938

Position	Description and kit content	Spare part kit order no.
33	Kit seals in contact with medium, EPDM, complete with packing sleeve (pos. 31) and scraper (pos. 20)	71065927
	Kit seals in contact with medium, FPM, complete with packing sleeve (pos. 31) and scraper (pos. 20)	71065929
	Kit seals in contact with medium, KALREZ, complete with packing sleeve (pos. 31) and scraper (pos. 20)	71065930
34	Protective sleeve, PEEK, incl. scraper For assembly version: – short, immersion depth up to 100 mm (3.94")	71104412
	Protective sleeve, PEEK, incl. scraper For assembly version: – long, immersion depth up to 235 mm (9.25")	71104414

**Note!**

To retrofit assemblies delivered before 11/2009 order protective sleeve and flange described in position 23.

**Additional spare parts**

Description	Order no.
Seal-kit ball valve, fiber-glass reinforced PTFE half shell and seal rings	71003602
2 pneumatic limit switches incl. adapter for Kinetrol ball-valve drive	71023473
20 retaining washers D6, A2	71103282

KALREZ O-rings and scraper (can be ordered individually):

Description	Order no.
Scraper PEEK	51518430
O-ring ID 26.20 W 3.00 AD 32.20	51511512
O-ring ID 20.00 W 2.00 AD 24.00	51512169
O-ring ID 44.20 W 3.00 AD 50.20	51511513
O-ring ID 11.00 W 2.00 AD 15.00	51502849
O-ring ID 19.00 W 3.00 AD 25.00	51502859

For assemblies delivered before 10/2008 different spare part kits are available.

## 7.5 Return

If the assembly has to be repaired, please return it **cleaned** to the appropriate sales center.  
Please use the original packaging, if possible.

Please enclose the completed "Declaration of De-Contamination" (copy the second to last page of these Operating Instructions) with the packaging and the transportation documents.  
No repair without completed "Declaration of De-Contamination"!

## 7.6 Disposal

Remove electronic components, e.g. electric limit position switches. Dispose of these components in accordance with regulations on the disposal of electronic waste.

You have to separately dispose of pressure cylinder, sensor holder and other components according to their material.

Please observe local regulations.

## 8 Technical data

### 8.1 Process

<b>Process pressure</b>	PA pressure cylinder:	Max. 6 bar (87 psi)
	Stainless steel pressure cylinder:	Max. 10 bar (145 psi)
	Pneumatic outlet safety seal:	Continuous operation: 6 bar (87 psi) / 100 °C (212 °F), short-term (max. 1 h): 5 bar (72.5 psi) / 140 °C (264 °F)
	Manual outlet safety seal:	6 bar (87 psi) / 20 °C (68 °F), 2 bar (29 psi) / 130 °C (265 °F)
<b>Process temperature</b>	PA pressure cylinder (manually only):	Max. 80 °C (176 °F)
	Stainless steel pressure cylinder:	Up to 100°C (212 °F) with continuous operation up to 6 bar (87 psi); short-term (max. 1 h): max. 140 °C (264 °F) at 5 bar (72.5 psi) max. 100 °C (212 °F) at 10 bar (145 psi)

**Pressure temperature diagram**

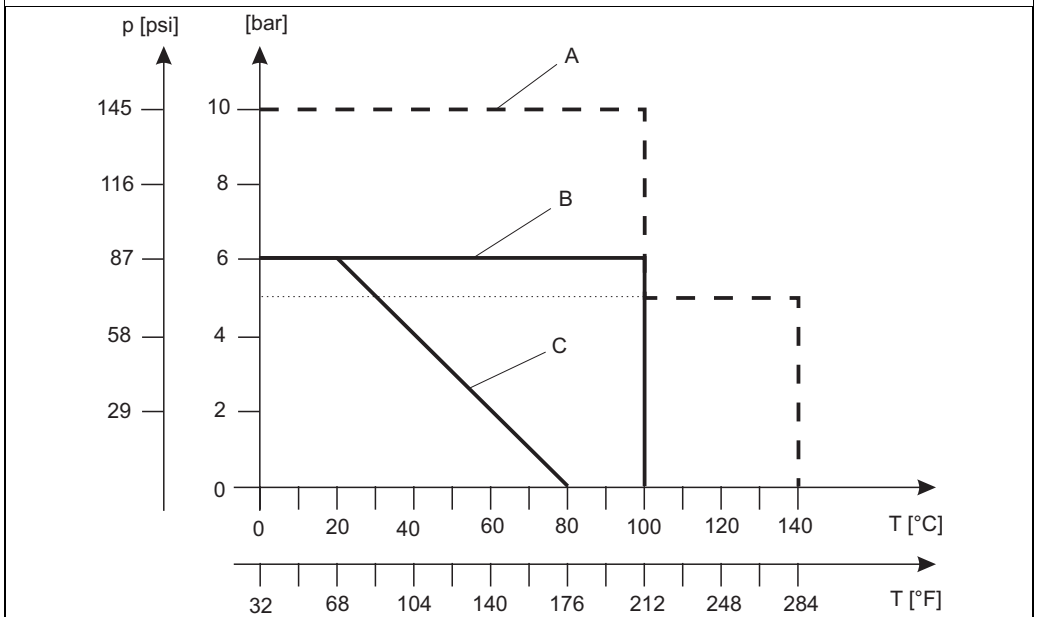

Fig. 44: Pressure-temperature diagram depending on the assembly material

- B Pressure cylinder (assembly) stainless steel 1.4404 (AISI 316L), short-term (max. 1h)
- A Pressure cylinder (assembly) stainless steel 1.4404 (AISI 316L)
- C Pressure cylinder (assembly) PA

<b>Flow velocity</b>	Max. 3 m/s (9.8 ft/s) Note! <ul style="list-style-type: none"> <li>■ A flow of 2 to 3 m/s (6.5 to 9.8 ft/s) should not be exceeded as otherwise measurable potentials can develop at the electrode.</li> <li>■ Within the permitted limits, mechanical stability does not depend on temperature and immersion depth.</li> </ul>
----------------------	---



**Caution!**  
The process pressure may not exceed 4 bar (58 psi) with manually actuated assemblies!

## 8.2 Environment

<b>Ambient temperature</b>	Ambient temperature not below 0 °C (32 °F). With an optional inlet/outlet safety seal, the ambient temperature may not exceed 80 °C (176 °F).
----------------------------	--

## 8.3 Mechanical construction

<b>Design, dimensions</b>	see chapter "Installation"	
<b>Sensors</b>	Short version	pH glass electrodes, Gel 225 mm (8.9") pH glass electrodes, KCl 425 mm (16.7") pH ISFET sensors, Gel, 225 mm (8.9") pH ISFET sensors, KCl, 425 mm (16.7")
	Long version	pH glass electrodes, Gel, 360 mm (14.2") pH ISFET sensors, Gel, 360 mm (14.2")
<b>Weight</b>	4 to 15 kg (8.8 to 33.1 lb), depending on the pressure cylinder material, the process connection, the drive and additional equipment, see product structure.	
<b>Material</b> (in contact with medium)	Seals Electrode holder  Ball valve  Inlet safety seal Outlet safety seal Rinse connection socket	EPDM / FPM / perfluoroelastomer Stainless steel 1.4404 (AISI 316L), electro-polished Stainless steel 1.4401 / 14408(AISI 316 / CF-8M), PTFE PVDF, PTFE, Viton® PVDF, Stainless steel 1.4404 (AISI 316L) Stainless steel 1.4404 (AISI 316L)
<b>Material</b> (not in contact with medium)	Pressure cylinder El. limit position switch	PA / stainless steel 1.4404 (AISI 316 L) fore-part PBT, cable PVC
<b>Rinse fittings</b>	2 x G¼ (internal) or 2 x NPT ¼" (internal)	



# Index

## A

Accessories	
Flow assembly	35
Hose connectors	36
Inlet and outlet safety seal	35
Limit position switches	36
Pressure reducer	34
Rinse connection adapter	35
Sensors	37
TopCal	38
Transmitters	38
Water filter	34
Assembly	
Cleaning	28

## B

Ball valve position	25
---------------------	----

## C

Calibration	29
Certificates	6
Checking	
Installation	22
Cleaning	
Agents	29
Assembly	28
Sensor	28
Cleaning interval	28
Commissioning	4, 23
Compressed air connection	15
Connection	
Compressed air	15–16
Rinse water	17

## D

Designated use	4
Dimensions	9
Dirt trap	34
Disposal	44

## E

Environment	46
-------------	----

## F

Flow assembly	35
---------------	----

## G

Gel sensors	21
-------------	----

## I

Icons	5
Immersion depth	9
Incoming acceptance	8
Inlet safety seal	18, 35
Installation	4, 8, 14
Immersion depth	9
ISFET sensor	8

## L

Limit position switch	15
Limit position switches	36
Liquid KCl sensor	22

## M

Maintenance	28
Maintenance interval	28
Manual operation	23
Measuring	23, 26
Measuring system	14
Mechanical construction	46
Medium	13

## N

Nameplate	6
-----------	---

## O

Operating elements	23
Operation	4
Manually	23
Pneumatically	24
Operational safety	4
Ordering information	7
Outlet safety seal	18–19, 35

## P

Parts	
Replacing	39
Pneumatic connection	15
Pneumatic operation	24
Pneumatic terminal block	16
Pneumatic throttle	15
Pressure reducer	34
Pressure surges	15, 17
Process	45
Process adapter	34
Process connection	10
Process pressure	11, 13
Product structure	7

## R

Replacing	
Parts	39
Seals	30
Retractable pipe	20
Retrofit kit	36
Return	4, 44
Rinse chamber	19
Inlet safety seal	18
Outlet safety seal	18
Rinse connection adapter	35
Rinse water connection	17



**S**

Safety icons . . . . .	5
Scope of delivery . . . . .	6
Scraper ring . . . . .	13
Sealing system . . . . .	12
Sealing-water function . . . . .	12
Sensor	
Cleaning . . . . .	28
Sensor holder . . . . .	20
Sensors . . . . .	37
Service . . . . .	23, 27
Spare parts . . . . .	40
Splash protection cap . . . . .	20
Stop lock bolt . . . . .	20, 23
Storage . . . . .	8
Symbols . . . . .	5

**T**

TopCal . . . . .	38
Transmitters . . . . .	38
Transport . . . . .	8

**U**

Use . . . . .	4
---------------	---

**W**

Wall spacing . . . . .	9
Water filter . . . . .	34



## Declaration of Hazardous Material and De-Contamination *Erklärung zur Kontamination und Reinigung*

**RA No.**

Please reference the Return Authorization Number (RA#), obtained from Endress+Hauser, on all paperwork and mark the RA# clearly on the outside of the box. If this procedure is not followed, it may result in the refusal of the package at our facility.  
*Bitte geben Sie die von E+H mitgeteilte Rücklieferungsnummer (RA#) auf allen Lieferpapieren an und vermerken Sie diese auch außen auf der Verpackung. Nichtbeachtung dieser Anweisung führt zur Ablehnung ihrer Lieferung.*

Because of legal regulations and for the safety of our employees and operating equipment, we need the "Declaration of Hazardous Material and De-Contamination", with your signature, before your order can be handled. Please make absolutely sure to attach it to the outside of the packaging.

*Aufgrund der gesetzlichen Vorschriften und zum Schutz unserer Mitarbeiter und Betriebseinrichtungen, benötigen wir die unterschriebene "Erklärung zur Kontamination und Reinigung", bevor Ihr Auftrag bearbeitet werden kann. Bringen Sie diese unbedingt außen an der Verpackung an.*

**Type of instrument / sensor**

Geräte-/Sensortyp \_\_\_\_\_

**Serial number**

Seriennummer \_\_\_\_\_

**Used as SIL device in a Safety Instrumented System / Einsatz als SIL Gerät in Schutzeinrichtungen**

**Process data / Prozessdaten**

Temperature / Temperatur \_\_\_\_\_ [°F] \_\_\_\_\_ [°C]      Pressure / Druck \_\_\_\_\_ [psi] \_\_\_\_\_ [Pa]  
Conductivity / Leitfähigkeit \_\_\_\_\_ [µS/cm]      Viscosity / Viskosität \_\_\_\_\_ [cp] \_\_\_\_\_ [mm<sup>2</sup>/s]

**Medium and warnings**

Warnhinweise zum Medium



	Medium /concentration <i>Medium /Konzentration</i>	Identification CAS No.	flammable <i>entzündlich</i>	toxic <i>giftig</i>	corrosive <i>ätzend</i>	harmful/ irritant <i>gesundheitsschädlich/ reizend</i>	other * <i>sonstiges*</i>	harmless <i>unbedenklich</i>
Process medium <i>Medium im Prozess</i>								
Medium for process cleaning <i>Medium zur Prozessreinigung</i>								
Returned part cleaned with <i>Medium zur Endreinigung</i>								

\* explosive; oxidising; dangerous for the environment; biological risk; radioactive

\* *explosiv; brandfördernd; umweltgefährlich; biogefährlich; radioaktiv*

Please tick should one of the above be applicable, include safety data sheet and, if necessary, special handling instructions.

*Zutreffendes ankreuzen; trifft einer der Warnhinweise zu, Sicherheitsdatenblatt und ggf. spezielle Handhabungsvorschriften beilegen.*

**Description of failure / Fehlerbeschreibung** \_\_\_\_\_

**Company data / Angaben zum Absender**

Company / Firma _____	Phone number of contact person / Telefon-Nr. Ansprechpartner: _____
Address / Adresse _____	Fax / E-Mail _____
	Your order No. / Ihre Auftragsnr. _____

"We hereby certify that this declaration is filled out truthfully and completely to the best of our knowledge. We further certify that the returned parts have been carefully cleaned. To the best of our knowledge they are free of any residues in dangerous quantities."

*"Wir bestätigen, die vorliegende Erklärung nach unserem besten Wissen wahrheitsgetreu und vollständig ausgefüllt zu haben. Wir bestätigen weiter, dass die zurückgesandten Teile sorgfältig gereinigt wurden und nach unserem besten Wissen frei von Rückständen in gefahrbringender Menge sind."*

\_\_\_\_\_  
(place, date / Ort, Datum)

\_\_\_\_\_  
Name, dept./Abt. (please print / bitte Druckschrift)

\_\_\_\_\_  
Signature / Unterschrift

[www.endress.com/worldwide](http://www.endress.com/worldwide)

---

**Endress+Hauser** 

People for Process Automation

