

Important Notice

⚠ CAUTION

Electrical shock could cause death or serious injury. If the sensor is installed in a high voltage environment and a fault or installation error occurs, high voltage may be present on the connection terminals or the probe itself.

Safe and secure operation of the temperature sensor can only be guaranteed if the operating instructions of the used transmitters and all included safety notes are read, understood and followed. For Endress+Hauser temperature transmitters see enclosed CD-ROM.

Correct use

The manufacturer cannot be held responsible for damage caused by misuse of the unit. The installation conditions and connection values indicated in the operating instructions must be followed!

Installation Guidelines and Safety instructions

1. Install the unit according to the relevant NEC Code and local regulations.
2. Avoid any spark due to impact, friction and installation. Anti-sparking wrenches should be utilized.
3. The temperature sensor should be connected to the power supply or other external circuit using the appropriate cable glands and wire entries.
4. For ambient temperature higher than 158 °F, suitable cables, conduit and conductors must be used. Only use approved wire entries.
5. When utilized in dust atmospheres, the connection between the housing, fittings and thermowell should provide a minimum degree of Ingress Protection.

Liquid/gas sealants should be used. Local regulations need to be respected.

⚠ CAUTION

Do not disconnect equipment unless power has been switched off or the area is not hazardous.

The accessories for pipe connections and the appropriate gaskets and sealing rings are not supplied with the sensors. These are the customer's responsibility. Depending on temperature and pressure operating conditions, the gaskets, the sealing and clamping rings and the applicable torques must be selected by the user.

For further information regarding connections, please refer to the corresponding Standards.

Installation and operation

The unit is constructed using the most up to date production equipment and complies with the safety requirements of the local guidelines. However, if it is installed incorrectly or misused, certain application dangers can occur. Installation, wiring and maintenance of the unit must only be completed by trained, skilled personnel who are authorized to do so by the plant operator. The plant operator must make sure that the measurement system has been correctly wired to the connection schematics. Procedures indicated in these instructions must be followed.

Returns

Please follow the Return Authorization Policy which is attached with this manual.

Safety pictograms and symbols



Notes draw attention to activities or procedures that can have a direct influence on operation or trigger an unforeseen device reaction if they are not carried out properly.

⚠ CAUTION

Cautions draw attention to activities or procedures that can lead to persons being seriously injured, to safety risks or to the destruction of the device if they are not carried out properly.

Though the information provided herein is believed to be accurate, be advised that the information contained herein is NOT a guarantee of satisfactory results. Specifically, this information is neither a warranty nor guarantee, expressed or implied, regarding performance; merchantability, fitness, or other matter with respect to the products; and recommendation for the use of the product/process information in conflict with any patent. Please note that Endress+Hauser reserves the right to change and/or improve the product design and specifications without notice.

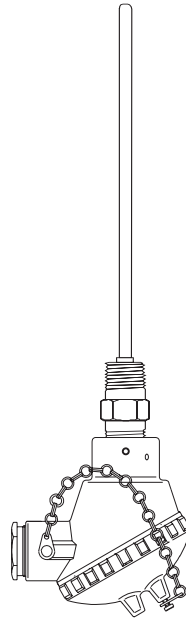

Measuring System
General purpose MgO insulated thermocouple with connection head for process and laboratory applications.
The thermocouple sensor complies with the ASTM E-230 and IEC60584 specifications. The sensor is designed to ensure highest accuracy and long term stability.

Compact Instructions
Thermocouple assembly
TH51

Type	Temperature range	Standard Tolerance in % and °C* (whichever is greater)	IEC class 1	IEC class 2
E	0 to 870	± 1.0 or ± 0.4%	± 1.7 or ± 0.5%	
J	0 to 760	± 1.1 or ± 0.4%	± 2.2 or ± 0.75%	
K	0 to 1260	± 1.1 or ± 0.4%	± 2.2 or ± 0.75%	
T	0 to 370	± 0.5 or ± 0.4%	± 1.0 or ± 0.75%	
N	0 to 1260	± 1.1 or ± 0.4%	± 2.2 or ± 0.4%	

* For measurement errors in °C, calculate using equation above in °C, then multiply the outcome by 1.8.

Insulation resistance
1,000 MΩ at 77 °F (25 °C) Insulation resistance for MgO insulated TC with ungrounded hot junction between terminals and probe sheath, test voltage 500 V DC. Value applies also between each TC wire at single and duplex construction with ungrounded hot junction.

Supplementary documentation
All important Temperature Operating Instructions, particularly with regard to head and field transmitters are available on CD-ROM, find enclosed or order by order number: **SONDT-AG**

www.addresses.endress.com

Response time	63% response time per ASTM E839	Unrounded	Grounded	junction style
0.4 s	1.6 s	2.4 s	0.9 s	Ø 1/8" / Ø 3/16" / Ø 1/4" / Ø 3/8"
0.3 s	0.6 s	1.3 s	3.5	
0.4 s	1.6 s	2.9 s	7.2 s	

Installation

Installation locations

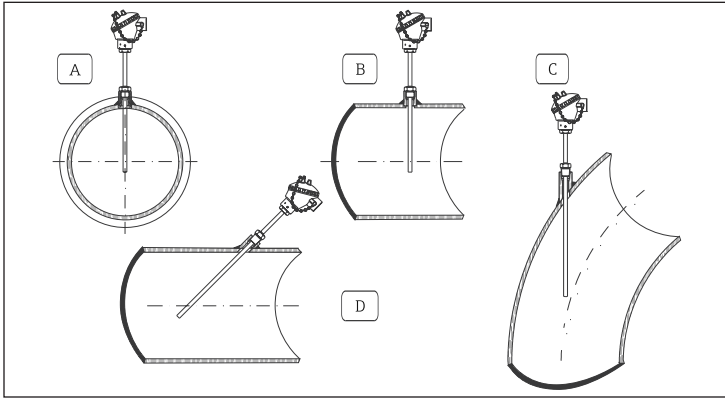

A, B: In pipes of a small section the axis line of the duct must be reached and if possible slightly exceeded by the tip of the probe.

C, D: Tilted installation.

For installation proceed as follows:

1. Seal the process connection thread or the pipe thread of the compression fitting with pipe thread sealant, e.g. "TFE" tape before screwing in the device.
2. Make sure that the process fitting matches the maximum specified process pressure.
3. Install and tighten the thermocouple before applying process pressure.



Minimum immersion length should be 10 times the OD of the sheath, nominal.

Dimensions

All dimensions in inches

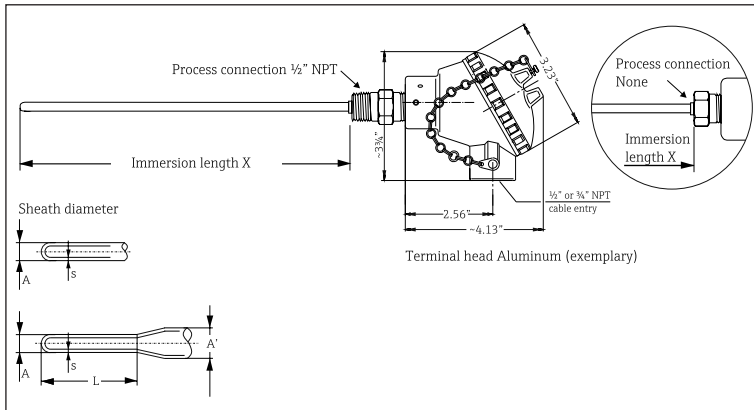

Immersion length X	Sheath diameter A	Wall thickness s
4", 6", 9", 12" specified length 2" to 96" in 1/2" increments	3/16"	0.007"
	1/8"	0.014"
	3/16"	0.022"
	1/4"	0.029"
	3/8"	0.045"

Electrical connection-wiring diagrams

Head mounted transmitter (single/dual)

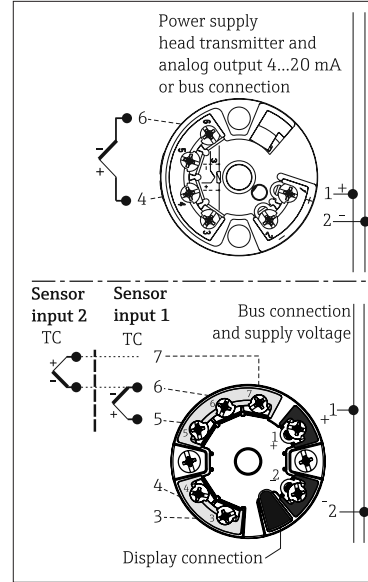

Field mounted transmitter

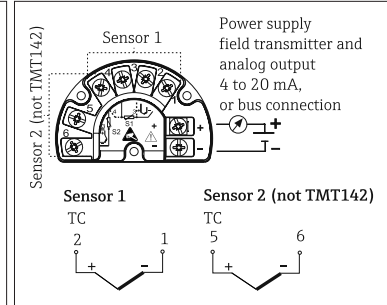

Terminal block mounted

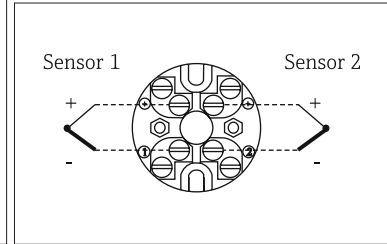

Wire specifications: Thermocouple grade, TFE insulated 20AWG, 7 strands with stripped ends

Flying leads, standard 3" for wiring in terminal head, head transmitter or terminal block mounted

Flying leads, 5 1/2" for wiring with field housing or field transmitter assembly



The blocks and transmitters are shown as they will sit inside the heads in reference to the conduit opening. ALWAYS terminate leads to the outside screw!

Technical data

Measurement range

Maximum element temperature range limits for various thermocouple types in °F (°C)				
Type T	Type J	Type E	Type K	Type N
-454 to 752 °F (-270 to +400 °C)	-346 to 2192 °F (-210 to 1200 °C)	-454 to 1832 °F (-270 to 1000 °C)	-454 to 2500 °F (-270 to 1372 °C)	-454 to 2372 °F (-270 to 1300 °C)

Weight

From 1 to 10 lbs

Material	Max. temp. rating	Application notes
316SS	1700 °F (927 °C)	Superior corrosion resistance. Duplex version of type N is not available with 316SS sheaths.
Inconel 600	2100 °F (1149 °C) ¹	Excellent oxidation and corrosion resistance at high temperature. Not to be used in sulphurous atmospheres over 1000 °F (538 °C). Types T & J are not available with Inconel 600 sheaths.

1) Max. working temperature under oxidizing conditions; reducing conditions reduce max. temp. to 1900 °F (1038 °C).

Shock and vibration resistance

4g/2 to 150 Hz as per IEC 60 068-2-6

Ambient temperature limits

Housing without head-mounted transmitter	
Aluminium pressure die-cast housing	-58 to 212 °F (-50 to 100 °C)
Stainless steel housing	-58 to 212 °F (-50 to 100 °C)
Housing with head-mounted transmitter	
All types of housing	-40 to 185 °F (-40 to 85 °C)
Field transmitter	
with display	-40 to 158 °F (-40 to 70 °C)
without display	-40 to 185 °F (-40 to 85 °C)