



Level



Pressure



Flow



Temperature



Liquid  
Analysis



Registration



Systems  
Components



Services



Solutions

## Brief Operating Instructions

# Prosonic M FMU40/41/42/43/44

## Ultrasonic Level Measurement

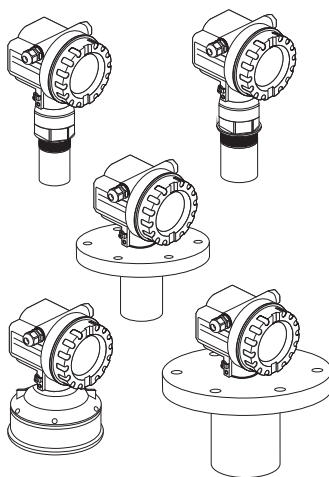

These Instructions are Brief Operating Instructions; they do not replace the Operating Instructions included in the scope of supply.

For detailed information, refer to the Operating Instructions and other documentation on the CD-ROM provided or visit "[www.endress.com/deviceviewer](http://www.endress.com/deviceviewer)".

KA01062F/00/EN/13.11  
71145350

# Table of contents

<b>1</b>	<b>Safety instructions</b>	<b>3</b>
1.1	Designated use	3
1.2	Installation, commissioning and operation	3
1.3	Operational safety and process safety	3
1.4	Return	4
1.5	Safety icons	4
<b>2</b>	<b>Mounting</b>	<b>4</b>
2.1	Incoming acceptance, storage	4
2.2	Installation	5
2.3	Installation conditions	7
2.4	Measuring range	10
2.5	Installation hint for FMU40/41	13
2.6	Turn housing	14
<b>3</b>	<b>Wiring</b>	<b>15</b>
3.1	Wiring in the housing F12	15
3.2	Wiring in the housing T12	16
3.3	Terminal assignment	16
3.4	Supply voltage	17
3.5	Potential matching	18
3.6	Checking the connection	18
<b>4</b>	<b>Operation</b>	<b>19</b>
4.1	Operating options	19
4.2	General structure of the operating menu	19
4.3	Display and operating elements	20
<b>5</b>	<b>Commissioning</b>	<b>23</b>
5.1	Function check	23
5.2	Switching on the measuring device	23
5.3	Basic Setup	24

# 1 Safety instructions

## 1.1 Designated use

The Prosonic M is a compact measuring device for continuous, non-contact level measurement. Depending on the sensor, the measuring range is up to 20m (66 ft) in fluids and up to 10m (33 ft) in bulk solids. By using the linearisation function, the Prosonic M can also be used for flow measurements in open channels and measuring weirs.

## 1.2 Installation, commissioning and operation

- The device must only be installed, connected, commissioned and maintained by qualified and authorized specialists (e.g. electrical technicians) in full compliance with the instructions in this manual, the applicable norms, legal regulations and certificates (depending on the application).
- The specialist must have read and understood this manual and must follow the instructions it contains. If you are unclear on anything in these Brief Operating Instructions, you must read the Operating Instructions (on the CD-ROM). The Operating Instructions provide detailed information on the device/measuring system.
- The device may only be modified or repaired if such work is expressly permitted in the Operating Instructions (→ see CD-ROM).
- If faults cannot be rectified, the device must be taken out of service and secured against unintentional commissioning.
- Do not operate damaged devices. Mark them as defective.



## 1.3 Operational safety and process safety

- Alternative monitoring measures must be taken to ensure operational safety and process safety during configuration, testing and maintenance work on the device.
- The device is safely built and tested according to state-of-the-art technology and has left the factory in perfect condition as regards technical safety. The applicable regulations and European standards have been taken into account.
- Pay particular attention to the technical data on the nameplate.
- If the device is to be installed in an explosion hazardous area, then the specifications in the certificate as well as all national and local regulations must be observed. The device is accompanied by separate "Ex documentation", which is an integral part of this Operating Instructions. The installation regulations, connection values and Safety Instructions listed in this Ex document must be observed. The documentation number of the related Safety Instructions is also indicated.
- If using devices for applications with safety integrity level, the separate manual on functional safety must be observed thoroughly (→ see CD-ROM).

## 1.4 Return

Follow the instructions on returning the device as outlined in the Operating Instructions on the CD-ROM provided.

## 1.5 Safety icons

Symbol	Meaning
	<b>Warning!</b> A warning highlights actions or procedures which, if not performed correctly, will lead to personal injury, a safety hazard or destruction of the instrument.
	<b>Caution!</b> Caution highlights actions or procedures which, if not performed correctly, may lead to personal injury or incorrect functioning of the instrument.
	<b>Note!</b> A note highlights actions or procedures which, if not performed correctly, may indirectly affect operation or may lead to an instrument response which is not planned.

# 2 Mounting

## 2.1 Incoming acceptance, storage

### 2.1.1 Incoming acceptance

Check the packing and contents for any signs of damage. Check the shipment, make sure nothing is missing and that the scope of supply matches your order.

### 2.1.2 Storage

Pack the measuring instrument so that is protected against impacts for storage and transport. The original packing material provides the optimum protection for this.

The permissible storage temperature is -40 °C to +80 °C (-40 °F to +176 °F).

## 2.2 Installation

### 2.2.1 Installation variants FMU40, FMU41

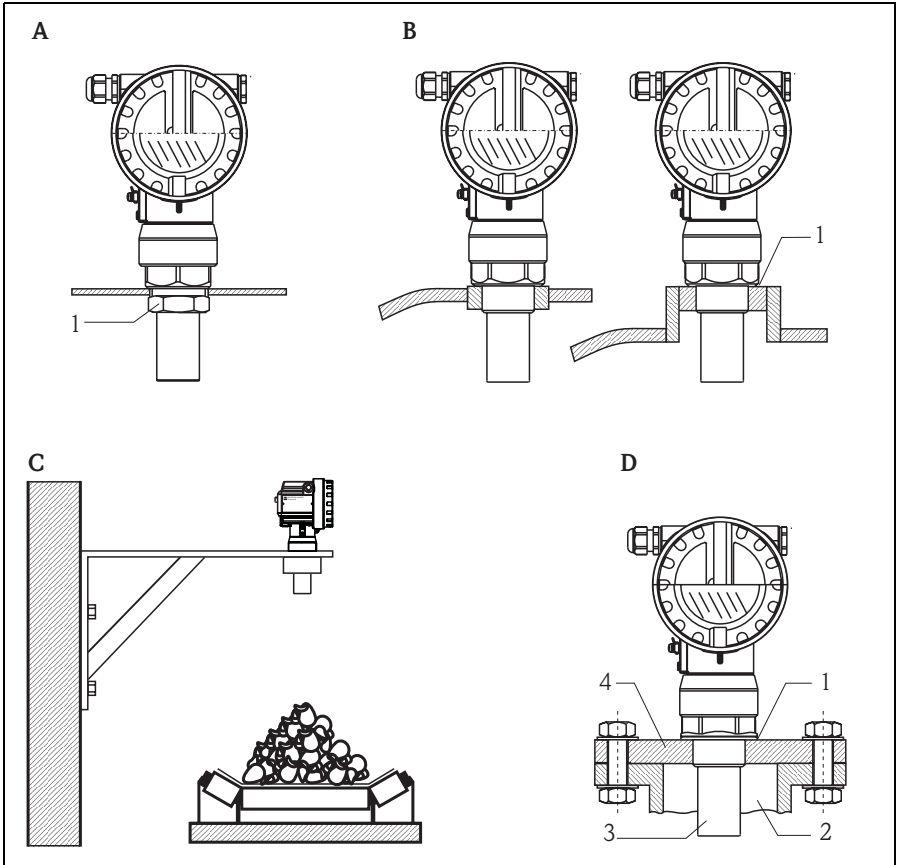

L00-FMU4xxxx-17-00-00-yy-002

- A** Installation with counter nut
  - 1 Counter nut (PC) supplied for G1½ and G2 instruments
- B** Installation with sleeve
  - 1 Sealing ring (EPDM) supplied
- C** Installation with installation bracket
- D** Installation with screw in flange
  - 1 Sealing ring (EPDM) supplied
  - 2 Nozzle
  - 3 Sensor
  - 4 Screw in flange

### 2.2.2 Installation variants FMU42, FMU44

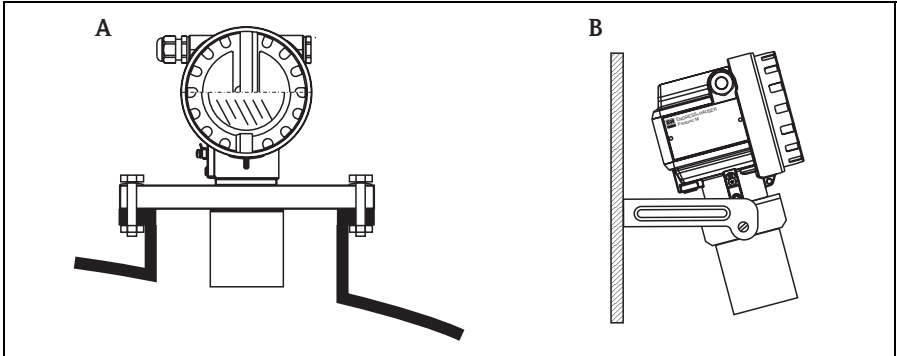

L00-FMU42xxxx-17-00-00-xx-002

- A Installation with universal flange
- B Installation with mounting bracket

### 2.2.3 Installation variants FMU43

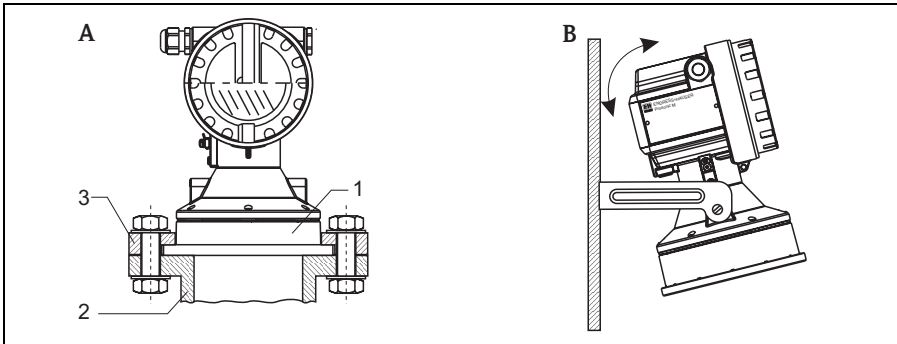

L00-FMU43xxxx-17-00-00-x-002

- A Installation with universal slip-on flange (option)
  - 1 Sensor
  - 2 Nozzle
  - 3 Slip-on flange
- B Installation with mounting bracket

## 2.3 Installation conditions

### 2.3.1 Installation conditions for level measurements

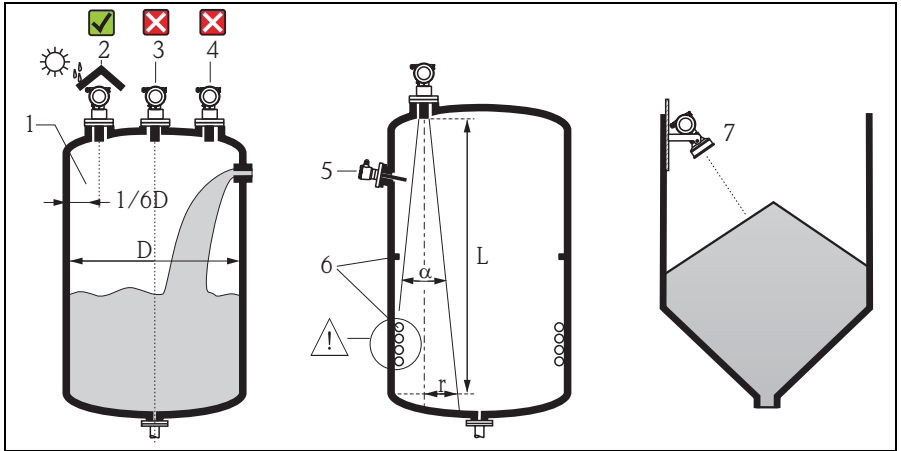

L00-FMU4xxxx-17-00-00-yy-005

- Do not install the sensor in the middle of the tank (3). We recommend leaving a distance between the sensor and the tank wall (1) measuring  $1/6D$  of the tank diameter.
- Use a protective cover, in order to protect the device from direct sun or rain (2), see the Technical Information TI00365F, Chapter "Accessories" on the CD-ROM provided.
- Avoid measurements through the filling curtain (4).
- Make sure that equipment (5) such as limit switches, temperature sensors, etc. are not located within the emitting angle  $\alpha$ . In particular, symmetrical equipment (6) such as heating coils, baffles etc. can influence measurement.
- Align the sensor so that it is vertical to the product surface (7).
- Never install two ultrasonic measuring devices in a tank, as the two signals may affect each other.
- To estimate the detection range, use the 3 dB emitting angle  $\alpha$ .

Sensor	$\alpha$	$L_{\max}$	$r_{\max}$
FMU40	11°	5 m (16 ft)	0.48 m (1.6 ft)
FMU41	11°	8 m (26 ft)	0.77 m (2.5 ft)
FMU42	9°	10 m (33 ft)	0.79 m (2.6 ft)
FMU43	6°	15 m (49 ft)	0.79 m (2.6 ft)
FMU44	11°	20 m (66 ft)	1.93 m (6.3 ft)

### 2.3.2 Installation in narrow shafts

In narrow shafts with strong interference echoes, we recommend using an ultrasound guide pipe (e.g. PE or PVC wastewater pipe) with a minimum diameter of 100 mm (3.94 in).

Make sure that the pipe is not soiled by accumulated dirt. If necessary, clean the pipe at regular intervals.

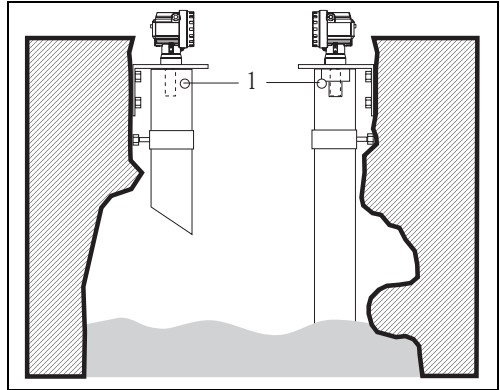

1 Venting hole

### 2.3.3 Installation conditions for flow measurements

- Install the Prosonic M at the inflow side, as close above the maximum water level  $H_{\max}$  as possible (take into account the blocking distance BD).
- Position the instrument in the middle of the channel or weir.
- Align the sensor membrane parallel to the water surface.
- Keep to the installation distance of the channel or weir.
- You can enter the "Flow to Level" linearisation curve ("Q/h curve") using operating program FieldCare or manually via the on-site display.



**Example: Khafagi-Venturi flume**

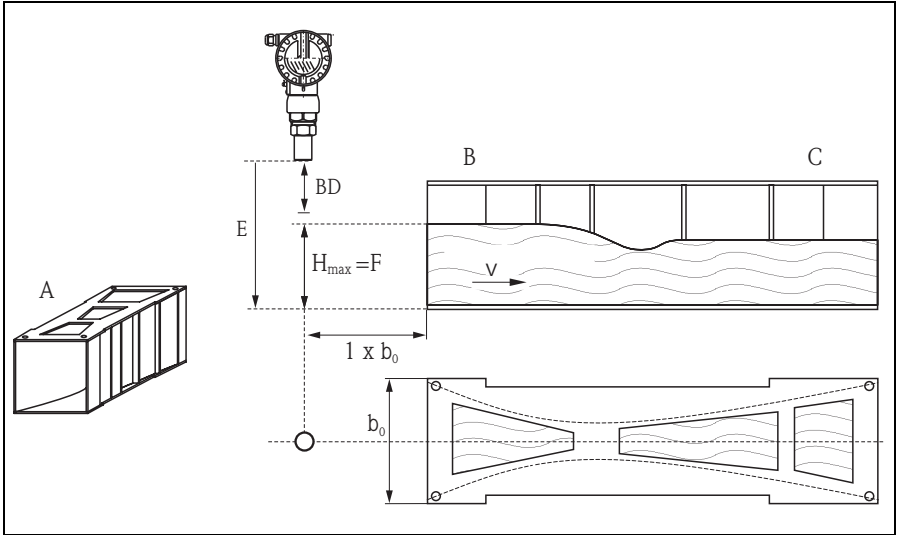

L00-FMU4xxx-17-00-00-xx-003

- A *Khafagi-Venturi flume*
- B *Inflow*
- C *Outflow*
- BD *Blocking distance*
- E *Empty calibration*
- F *Full calibration*
- V *Direction of flow*

**Example: Triangular weir**

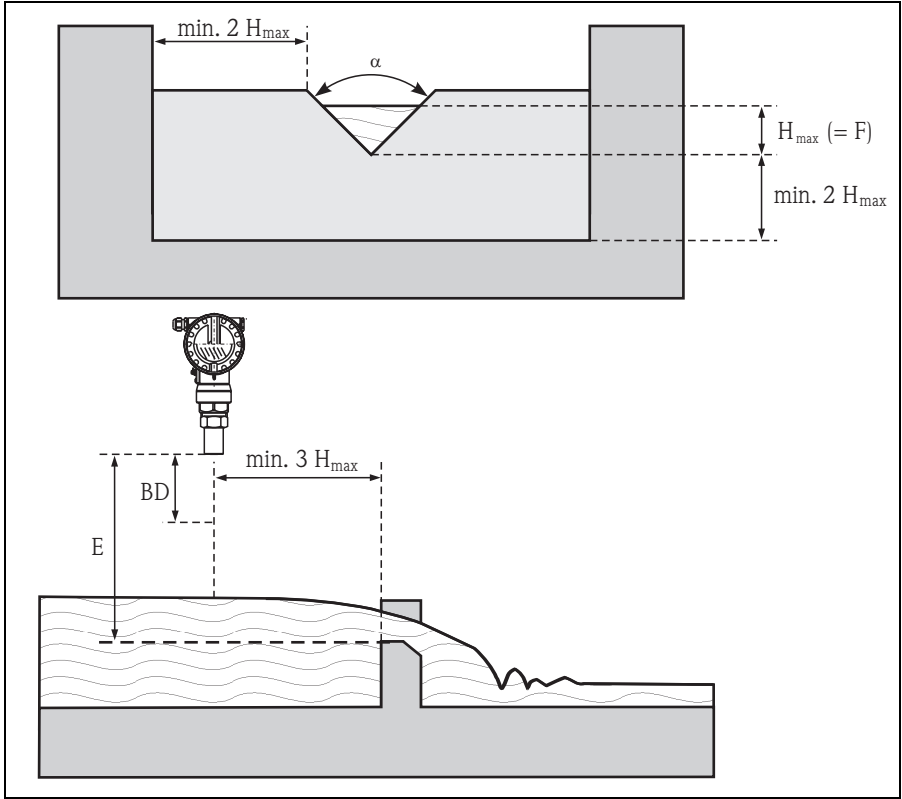

L00-FMU4xxxx-17-00-00-xx-012

- BD* Blocking distance
- E* Empty calibration
- F* Full calibration

**2.4 Measuring range**

**2.4.1 Blocking distance, Nozzle mounting**

Install the instrument at a height so that the blocking distance BD is not undershot, even at maximum fill level. Use a pipe nozzle if you cannot maintain the blocking distance in any other way. The interior of the nozzle must be smooth and may not contain any edges or welded joints. In particular, there should be no burr on the inside of the tank side nozzle end. Note the specified limits for nozzle diameter and length. To minimise disturbing factors, we recommend an angled socket edge (ideally 45°).

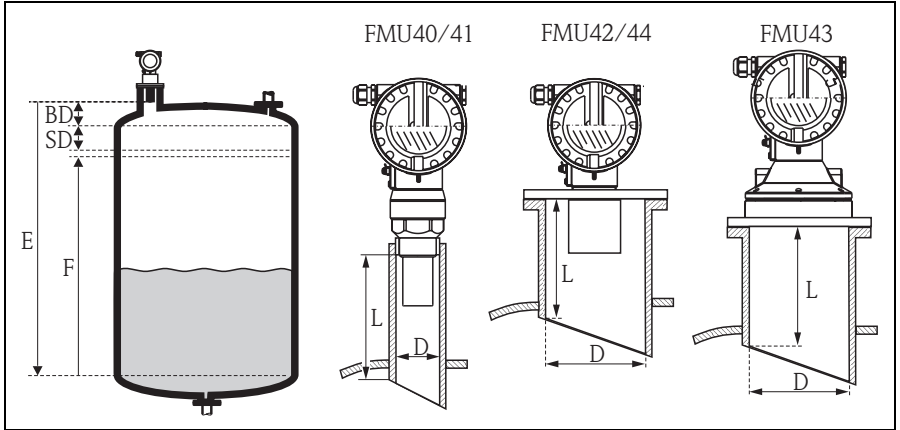

L00-FMU4Kxxx-17-00-00-yy-004

BD Blocking distance  
 SD Safety distance  
 E Empty calibration

F Full calibration (span)  
 D Nozzle diameter  
 L Nozzle length

Nozzle diameter	Maximum nozzle length [mm (in)]				
	FMU40	FMU41	FMU42	FMU43	FMU44
DN50/2"	80 (3.15)				
DN80/3"	240 (9.45)	240 (9.45)	250 (9.84)		
DN100/4"	300 (11.8)	300 (11.8)	300 (11.8)	300 (11.8)	
DN150/6"	400 (15.7)	400 (15.7)	400 (15.7)	300 (11.8)	400 (15.7)
DN200/8"	400 (15.7)	400 (15.7)	400 (15.7)	300 (11.8)	400 (15.7)
DN250/10"	400 (15.7)	400 (15.7)	400 (15.7)	300 (11.8)	400 (15.7)
DN300/12"	400 (15.7)	400 (15.7)	400 (15.7)	300 (11.8)	400 (15.7)
<b>Sensor characteristics</b>					
Emitting angle $\alpha$	11°	11°	9°	6°	11°
Blocking distance [m (ft)]	0.25 (0.8)	0.35 (1.1)	0.4 (1.3)	0.6 (2.0)	0.5 (1.6)
Max. range [m (ft)] in liquids	5 (16.0)	8 (26.0)	10 (33.0)	15 (49.0)	20 (66.0)
Max. range [m (ft)] in solids	2 (6.6)	3.5 (11.0)	5 (16.0)	7 (23.0)	10 (33.0)



**Caution!**

If the blocking distance is undershot, it may cause device malfunction.

### 2.4.2 Safety distance

If the level rises to the safety distance SD, the device switches to warning or alarm status. The size of SD can be set freely in the **"Safety distance" (015)** function. The **"in safety distance" (016)** function defines how the device reacts if the level enters the safety distance.

There are three options:

- **Warning:** The device outputs an error message but continues measurement.
- **Alarm:** The device outputs an error message. The output signal assumes the value defined in the **"Output on alarm" (011)** function (MAX, MIN, user-specific value or holds the last value). As soon as the level drops below the safety distance, the device recommences measurement.
- **Self holding:** The device reacts in the same way as for an alarm. However, the alarm condition continues after the level drops below the safety distance. The device only recommences measurement when you cancel the alarm using the **"Ackn. alarm" (017)** function.

### 2.4.3 Range

The sensor range is dependent on the measuring conditions. Refer to Technical Information TI00365F/00/EN for an estimation. The maximum range is shown in the above diagram (valid for good conditions).

Sensor	maximum range [mm (inch)]
FMU40	5 (16)
FMU41	8 (26)
FMU42	10 (33)
FMU43	15 (49)
FMU44	20 (66)

## 2.5 Installation hint for FMU40/41



Caution!

Use only the screw-in piece to screw in the Prosonic M.

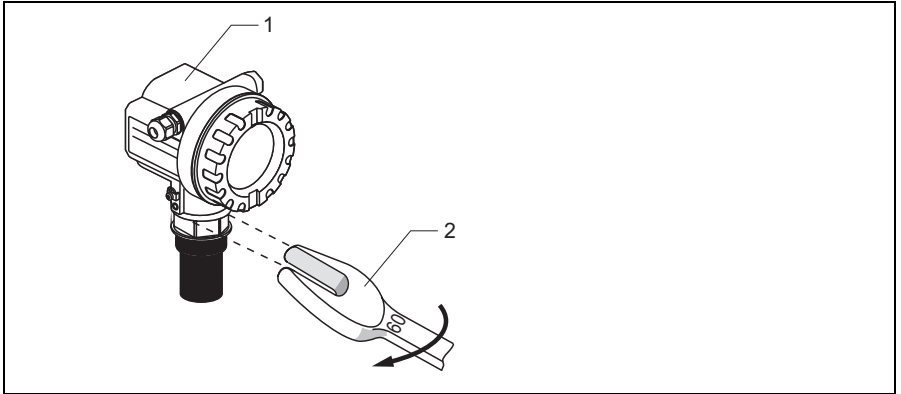

L00-FMU4xxxx-17-00-00-yy-009

1 Housing F12 or T12

2 00 AF, max. torque 20 Nm (14.75 lbf.ft)

## 2.6 Turn housing

After mounting, the housing can be turned 350° in order to simplify access to the display and the terminal compartment. Proceed as follows to turn the housing to the required position:

- Undo the fixing screws (1) (allen key 4 mm (0.16 in))
- Turn the housing (2) in the required direction
- Tighten up the fixing screws (1). Maximum torque 0.5 Nm (0.36 lbf ft).
- Loctite can be used for securing the screw.

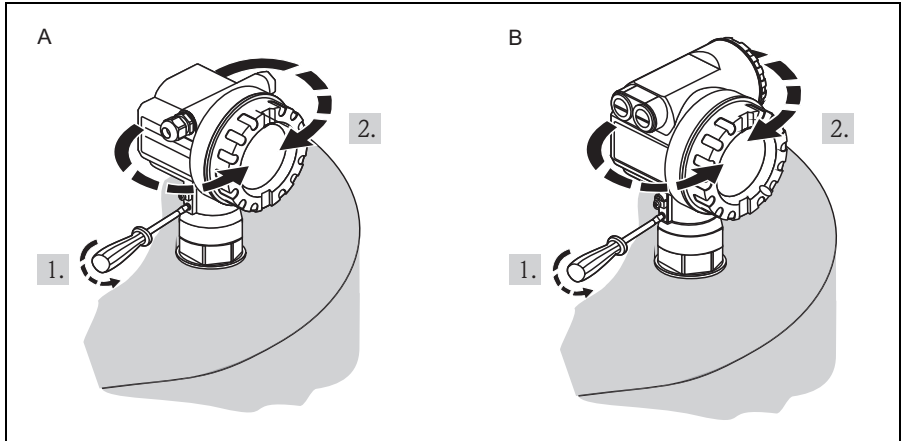

A Housing F12

B Housing T12

L00-FMU4xxxx-17-00-00-yy-013

### 2.6.1 Installation check

After installing the device, carry out the following checks:

- Is the device damaged (visual inspection)?
- Does the device correspond to the measuring point specifications for process temperature, process pressure, ambient temperature, measuring range etc.
- If available: Are the measuring point number and labelling correct (visual inspection)?
- Is the measuring device sufficiently protected against precipitation and direct sunlight?
- Are the cable glands tightened correctly?
- After aligning the housing, check the process seal at the nozzle or flange.

### 3 Wiring



#### Warning!

When you use the measuring system in hazardous areas, make sure to comply with national standards and the specifications in the safety instructions (XA's). Make sure you use the specified cable gland.



#### Caution!

Before connection please note the following:

- The power supply must be identical to the data on the nameplate.
- Switch off power supply before connecting up the instrument.
- Use a screened cable when working with a superimposed communications signal (HART).
- Connect equipotential bonding to transmitter ground terminal before connecting up the instrument (→ 18 "Potential matching")

#### 3.1 Wiring in the housing F12

1. Unscrew housing cover (1).
2. Remove display (2) if fitted.
3. Remove cover plate (3) from terminal compartment.
4. Pull out terminal module (4) slightly using pulling loop.
5. Insert cable (5) through gland (6).
6. Make connection according to terminal assignment (see terminal assignment).
7. Re-insert terminal module (4).
8. Tighten cable gland (6).
9. Tighten screws on cover plate (3).
10. Insert display (2) if fitted.
11. Screw on housing cover (1).
12. Switch on power supply.

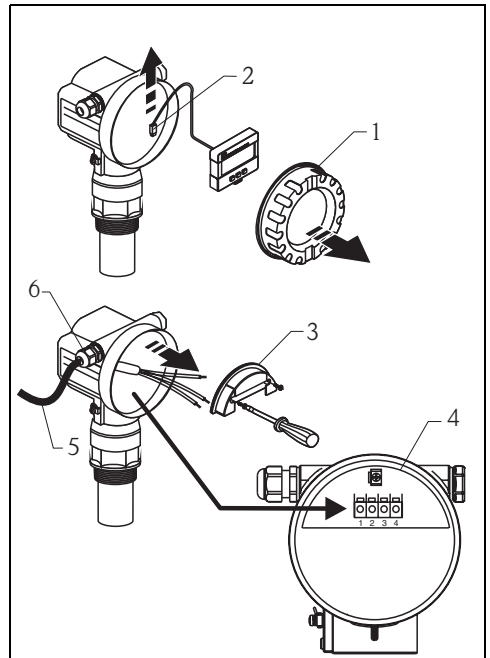

L00-FMxxxxxx-04-00-00-xx-033

### 3.2 Wiring in the housing T12

1. Unscrew the cover (1) of the separate connection room.
2. Insert cable (2) through gland (3).
3. Connect cable screen to the grounding terminal (4) within the connection room.
4. Make connection according to the terminal assignment (see below).
5. Tighten cable gland (3).
6. Screw on housing cover (1).
7. Switch on power supply.

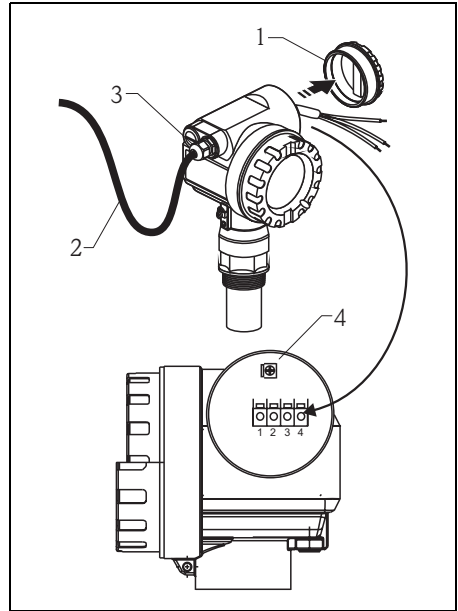

L00-FMxxxxx-04-00-00-xx-032

### 3.3 Terminal assignment

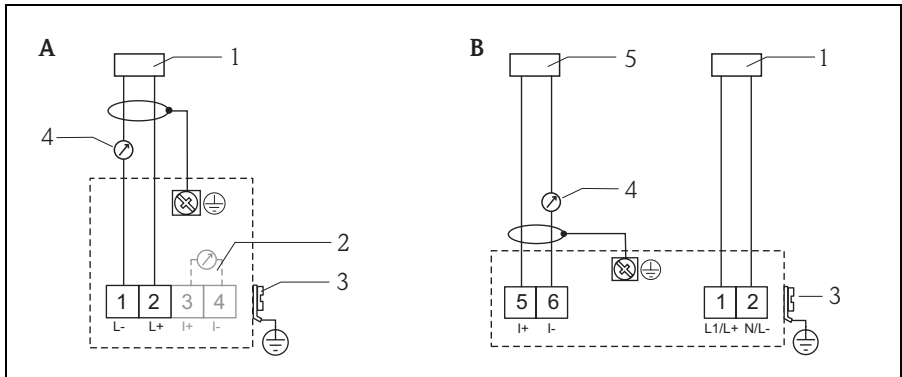

L00-FMxxxxx-04-00-00-xx-040

- |   |  |
|---|--|
| <p><b>A</b> Loop-powered version</p> <p><b>B</b> 4-wire version (active)</p> <p>1 Power</p> <p>2 Test clamp for testing of the signal current</p> | <p>3 Plant ground</p> <p>4 4...20 mA HART</p> <p>5 Display unit, recorder, PCS</p> |
|---|--|



**Note!**

- When operating via a handheld terminal or via a PC with an operating program, a minimum communication resistance of 250  $\Omega$  must be taken into account. Observe the max. load → 17.
- The connecting options for Commubox FXA195 or Field Communicator 375, 475, see Technical Information TI00404F.
- More Information of the complete measuring system, see the Technical Information TI00365F on the CD-ROM provided.

## 3.4 Supply voltage

### 3.4.1 HART, 2-wire

The following values are the voltages across the terminals directly at the instrument:

Version		Current consumption	Terminal voltage minimum	Terminal voltage maximum
2-wire HART	Standard	4 mA	14 V	36 V
		20 mA	8 V	36 V
Fixed current, adjustable, e.g. for solar power operation (measured value via HART)		11 mA	10 V	36 V
Fixed current for HART multidrop mode		4 mA <sup>1)</sup>	14 V	36 V

1) Start-up current 11 mA

### 3.4.2 HART, 4-wire, active

Version	Voltage	max. load
DC	10.5 ... 32 V	600 $\Omega$
AC 50/60 Hz	90 ... 253 V	600 $\Omega$

**Caution!**

When using the public powers supply, install an easy accessible power switch in the proximity of the instrument. Mark the power switch as a disconnecter for the instrument (IEC/EN 61010).

### 3.5 Potential matching

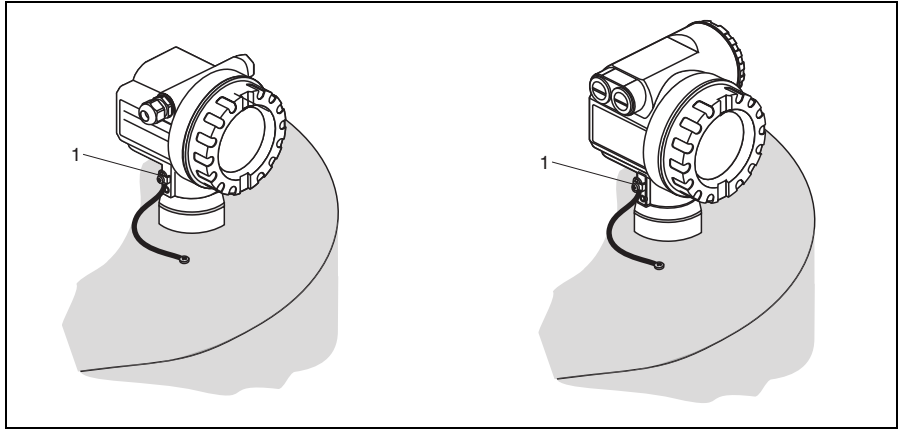

1 External ground terminal of the transmitter

L00-FMU4xxxx-17-00-00-yy-014

Connect the equipotential bonding to the external ground terminal of the transmitter.

#### ⚠ Caution!

In Ex applications, the instrument must only be grounded on the sensor side. Further safety instructions are given in the separate documentation for applications in explosion hazardous areas.

#### ✎ Note!

Since the housing is isolated from the tank by the plastic sensor, interference signals may occur if the potential matching line is not properly connected.

For optimum electromagnetic compatibility the potential matching line should be as short as possible and at least 2.5 mm<sup>2</sup> (14 AWG) in cross-section.

If increased electromagnetic interference is to be expected due to the installation conditions, we recommend usage of a ground strap.

### 3.6 Checking the connection

After wiring the device, carry out the following checks:

- Are the terminals correctly assigned?
- Is the cable gland tight?
- Is the housing cover fully screwed on?
- If power supply available: Does a display appear on the display module?

## 4 Operation

### 4.1 Operating options

- Via the operating and display module
- Via the service interface of the device with the Commubox FXA291 and the operating program "FieldCare"
- Via the HART protocol, e.g. with the Commubox FXA195 and the operating program "FieldCare"
- Via the Field Communicator 375, 475

### 4.2 General structure of the operating menu

The operating menu is made up of two levels:

- **Function groups (00, 01, 03, ..., 0C, 0D):**  
The individual operating options of the instrument are split up roughly into different function groups. The function groups that are available include, e.g.: "**basic setup**", "**safety settings..**", "**output**", "**display**", etc.
- **Functions (001, 002, 003, ..., 0D8, 0D9):**  
Each function group consists of one or more functions. The functions perform the actual operation or parameterisation of the instrument. Numerical values can be entered here and parameters can be selected and saved. The available functions of the "**basic setup**" (00) function group include, e.g.: "**tank shape**" (002), "medium property" (003), "**process cond.**" (004), "empty calibr." (005), etc.

If, for example, the application of the instrument is to be changed, carry out the following procedure:

1. Select the "**basic setup**" (00) function group
2. Select the "**tank shape**" (002) function (where the existing tank shape is selected).

#### 4.2.1 Identifying the functions

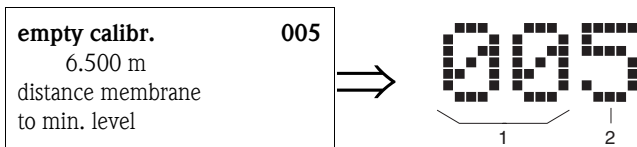

For simple orientation within the function menus, for each function a position is shown on the display.



- 1 Function group
- 2 Function



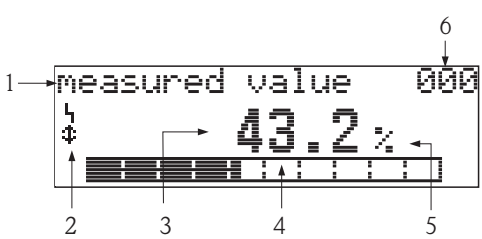
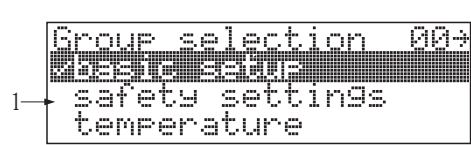

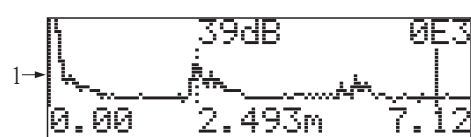
### 4.3.2 Display

<p><b>measured value display</b></p> 	<ol style="list-style-type: none"><li>1. label</li><li>2. symbol</li><li>3. value</li><li>4. bargraph</li><li>5. unit</li><li>6. position in menu</li></ol>
<p><b>group selection</b></p> 	<ol style="list-style-type: none"><li>1. selection list</li></ol>
<p><b>Function with free parameter</b></p> 	<ol style="list-style-type: none"><li>1. label</li><li>2. help texts</li><li>3. position in menu</li></ol>
<p><b>envelope curve</b></p> 	<ol style="list-style-type: none"><li>1. envelope curve</li></ol>















In the measured value display, the bargraph corresponds to the output. The bargraph is segmented in 10 bars. Each completely filled bar represents a change of 10 % of the adjusted span.

### 4.3.3 Display symbols

The following table describes the symbols that appear on the liquid crystal display:

Symbol	Meaning
	<b>ALARM_SYMBOL</b> This alarm symbol appears when the instrument is in an alarm state. If the symbol flashes, this indicates a warning.
	<b>LOCK_SYMBOL</b> This lock symbol appears when the instrument is locked, i.e. if no input is possible.
	<b>COM_SYMBOL</b> This communication symbol appears when a data transmission via e.g. HART, PROFIBUS PA or FOUNDATION Fieldbus is in progress.

### 4.3.4 Function of the keys

Key(s)	Meaning
 or 	Navigate upwards in the selection list Edit numeric value within a function
 or 	Navigate downwards in the selection list Edit numeric value within a function
 or 	Navigate to the left within a function group
	Navigate to the right within a function group, confirmation.
 and  or  and 	Contrast settings of the LCD
 and  and 	Hardware lock / unlock After a hardware lock, an operation of the instrument via display or communication is not possible! The hardware can only be unlocked via the display. An unlock parameter must be entered to do so.

## 5 Commissioning

### 5.1 Function check

Make sure that all final checks have been completed before you start up your measuring point:

- Checklist "Post-installation check".
- Checklist "Post-connection check".

### 5.2 Switching on the measuring device

After switching on the supply voltage, the instrument is first initialised. Then the following appear for approximately five seconds:

- Device type
- Software version
- Type of digital communication signal

Function	Aktion
→ language	Select the language (this message appears the first time the instrument is switched on)
→ distance unit	Select the basic unit (this message appears the first time the instrument is switched on)
→ measured value	The current measured value is displayed. This function displays the current measured value in the selected unit (see " <b>customer unit</b> " (042) function). The number of digits after decimal point can be selected in the " <b>no.of decimals</b> " (095) function. For details, see the documentation "Description of Instrument Functions" BA00240F on the CD-ROM provided.
→ group selection	After E is pressed, you reach the group selection. This selection enables you to perform the basic setup →  26.

### 5.3 Basic Setup

#### 5.3.1 Overview basic setup

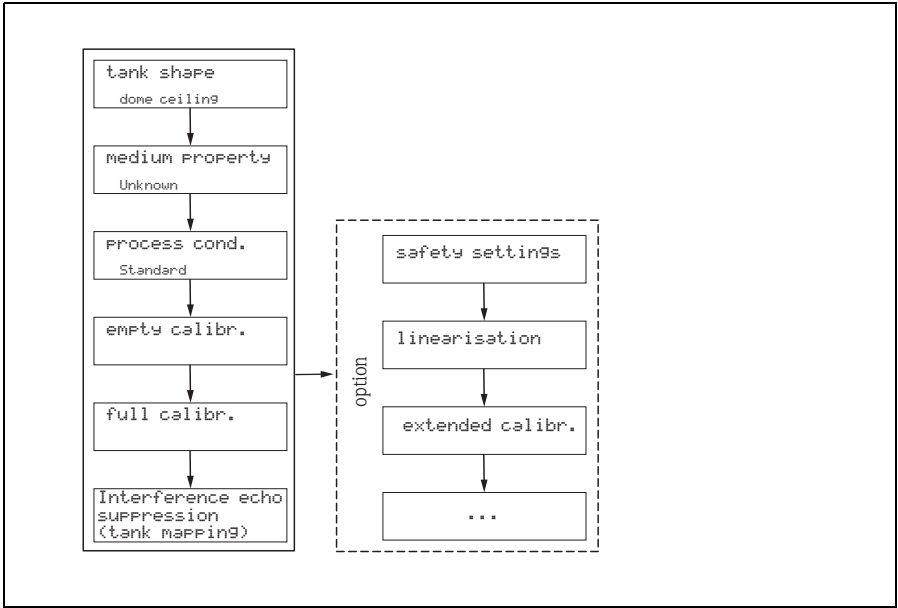



L00-FMxxxxx-19-00-00-en-001



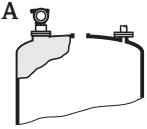
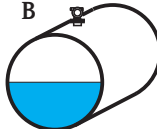
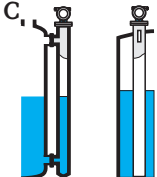
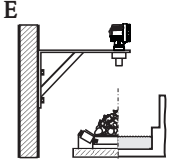

The "**Basic setup**" (00) function group lists all the functions which are required for a standard measurement task to commission the device. When you have completed your input for a function, the next function appears automatically. In this way, you are guided through the complete calibration.

Step	Function	Remarks
<b>Measuring point settings</b> (Details → Chap. 5.3.2)		
1	→ tank shape (002)	Select the appropriate values for your application.
2	→ medium property (003)	
3	→ process cond (004)	
<b>Empty and Full calibration</b> (Details → Chap. 5.3.3)		
4	→ empty calibration (005)	Specify the distance between the sensor membrane and the minimum level (0%).
5	→ block distance (059)	Display parameter; When entering the full calibration (span), please take into account, that the maximum level may not project into the blocking distance (BD).
6	→ full calibration (006)	Specify the distance between the minimum (0%) and maximum (100%) level.
<b>Interference echo suppression (tank mapping)</b> (Details → Chap. 5.3.3)		
7	→ dist./measured value (008)	The <b>distance</b> measured from the reference point to the product surface and the <b>meas. value</b> calculated with the aid of the empty adjustment are displayed.
8	→ check distance (051)	This function triggers the mapping of interference echoes. To do so, the measured distance must be compared with the actual distance to the product surface. The following options are available for selection: <b>Selection:</b> <ul style="list-style-type: none"> <li>■ distance = ok</li> <li>■ dist. too small</li> <li>■ dist. too big</li> <li>■ dist. unknown</li> <li>■ <b>manual</b></li> </ul>
9	→ range of mapping (052)	The suggested suppression area is displayed in this function. The reference point is always the sensor membrane. You can still edit the value.
10	→ start mapping (053)	Selection: <ul style="list-style-type: none"> <li>■ <b>off</b>: no mapping is carried out</li> <li>■ <b>on</b>: mapping is started</li> </ul>
11	→ dist./measured value (008)	After suppression, the measured distance D from the sensor membrane to the product surface is displayed together with the level.
<b>Envelope curve</b> (Details → Chap. 5.3.3)		
12	→ plot settings (0E1)	After the basic setup, an evaluation of the measurement with the aid of the envelope curve (" <b>envelope curve</b> " (0E) function group) is recommended.

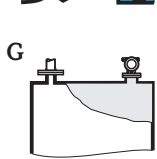

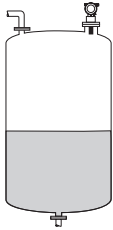
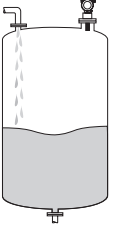
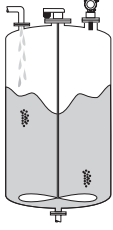
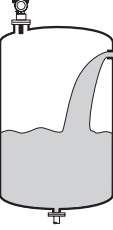
### 5.3.2 Measuring point settings

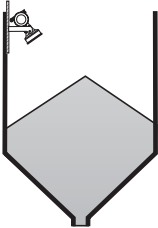
Function	Remarks
<p>"tank shape" (002)</p>	<p>In this function, select one of the following options:</p> <p><b>Selection:</b></p> <ul style="list-style-type: none"> <li>■ <b>dome ceiling</b> (→ A)</li> <li>■ horizontal cyl. (→ B)</li> <li>■ bypass (→ C)</li> <li>■ stilling well (ultrasonic guide pipe) (→ C)</li> <li>■ no ceiling (→ D)</li> <li>■ sphere (→ E)</li> <li>■ flat ceiling (→ F)</li> </ul> <div style="display: flex; flex-wrap: wrap; justify-content: space-around;"> <div style="text-align: center; margin: 10px;">  <p>A</p> </div> <div style="text-align: center; margin: 10px;">  <p>B</p> </div> <div style="text-align: center; margin: 10px;">  <p>C</p> </div> <div style="text-align: center; margin: 10px;">  <p>E</p> </div> <div style="text-align: center; margin: 10px;">  <p>F</p> </div> <div style="text-align: center; margin: 10px;">  <p>G</p> </div> </div> <p style="text-align: right; font-size: small;">L00-FMU4KAxx-14-00-06-xx-024</p>
<p>"medium property" (003)</p>	<p>Set the medium type in this function.</p> <p>You have the following options</p> <ul style="list-style-type: none"> <li>■ <b>unknown (e.g. pasty media such as greases, creams, gels etc.)</b></li> <li>■ liquid</li> <li>■ solid, grain size &lt; 4 mm (fine)</li> <li>■ solid, grain size &gt; 4 mm (coarse)</li> </ul>
<p>"process cond" (004)</p>	<p>Use this function to specify the process conditions of your application. The filters of the signal evaluation are automatically adjusted to the selected conditions.</p> <p>For this function, you have the following options → see the table:</p>

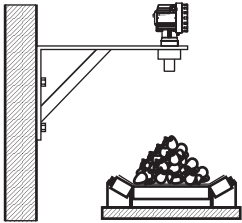
"process conditions"	for the following situations	Example	filter settings
standard liquid	For all fluid applications which do not fit in any of the following groups		The filters and output damping are set to average values.
calm surface	Storage tanks with immersion tube or bottom filling		The averaging filters and output damping are set to large values. -> stable measured value -> accurate measurement -> slow reaction time
turbulent surface	Storage/accumulation tanks with uneven surface due to free filling, mixing nozzles or small bottom stirrers		Special filters for stabilizing the input signal are activated. -> stable measured value -> medium reaction time
additional agitator	Moving surfaces (possibly with vortex formation) due to agitators		Special filters for stabilizing the input signal are set to large values. -> stable measured value -> medium reaction time
fast change	Rapid level change, particularly in small tanks		The averaging filters are set to small values. -> rapid reaction time -> possibly unstable measured value

"process conditions"	for the following situations	Example	filter settings
standard solid	For all bulk solid applications which do not fit in any of the following groups.		The filter and output damping are set to average values.
solid dusty	Dusty bulk solids		The averaging filters are set to detect even relatively weak signals.
conveyor belt	Bulk solids with rapid level change		The averaging filters are set to small values. -> rapid reaction time -> possibly unstable measured value
test: no filter	For service and diagnosis only		All filters are switched off.

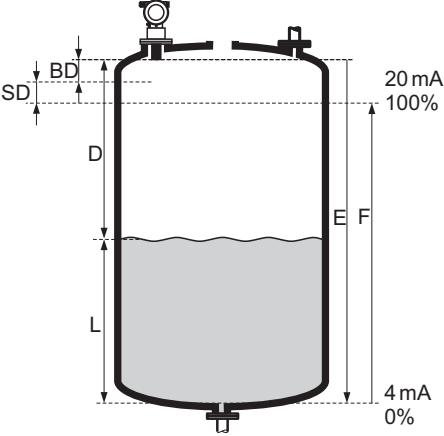
### 5.3.3 Empty and full calibration

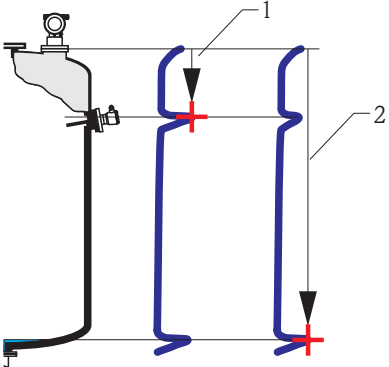

Function	Remarks
<p>"empty calibr." (005)</p>	<p>This function is used to enter the distance from the sensor membrane (reference point of the measurement) to the minimum level (=zero).</p> <p> <b>Caution!</b> With dished boiler heads or conical outflows, the zero point should not be deeper than the point at which the ultrasonic wave impinges on the tank bottom.</p>  <p><i>BD</i> Blocking distance  <i>SD</i> Safety distance  <i>E</i> Empty calibration (= zero point)  <i>F</i> Full calibration (= span)  <i>D</i> Nozzle diameter  <i>L</i> Level</p> <p style="text-align: right;"><small>L00-FM14xxxx-19-00-00-yy-019</small></p>
<p>"blocking distance" (059)"</p>	<p>In this function the blocking distance (BD) of the sensor is displayed.</p> <p> <b>Caution!</b> When entering the full calibration (span), please take into account, that the maximum level may not project into the blocking distance (BD).</p> <p> <b>Note!</b> After basic calibration, enter a safety distance (SD) in the <b>"safety distance" (015)</b> function. If the level is within this safety distance, the device signals a warning or an alarm, depending on your selection in the <b>"in safety distance" (016)</b> function.</p>
<p>"full calibr." (006)</p>	<p>This function is used to enter the distance from the minimum level to the maximum level (=span).</p>

### 5.3.4 Interference echo suppression (tank mapping)

Function	Remarks
"dist./meas.value" (008)	The <b>distance</b> measured from the reference point to the product surface and the <b>meas. value</b> calculated with the aid of the empty adjustment are displayed. Check whether the values correspond to the actual meas. value or the actual distance.
"check distance" (051)	<p>This function triggers the mapping of interference echoes. To do so, the measured distance must be compared with the actual distance to the product surface. The following options are available for selection:</p> <p><b>Selection:</b></p> <ul style="list-style-type: none"> <li>■ distance = ok</li> <li>■ dist. too small</li> <li>■ dist. too big</li> <li>■ dist. unknown</li> <li>■ <b>manual</b></li> </ul> <div style="text-align: center;">  <p>1 Distance too small 2 Distance = ok</p> </div> <p style="text-align: right; font-size: small;">L00-FMR2KAcc-14-00-06-xx-010</p> <p>Select:</p> <ul style="list-style-type: none"> <li>■ <b>"distance=ok"</b> if the correct distance is displayed. Any echoes closer to the sensor will be suppressed by the following interference echo suppression.</li> <li>■ <b>"dist. too small"</b> if the displayed distance is too small. In this case, the signal comes from an interference echo which will be suppressed.</li> <li>■ <b>"dist. too big"</b> if the displayed distance is too large. This error cannot be cancelled by suppressing the interference echo. This means that the following two functions are skipped. Check the application parameters <b>"tank shape" (002)</b>, <b>"medium property" (003)</b> and <b>"process cond." (004)</b> and the "empty calibr." (005) in the <b>"basic setup" (00)</b> function group.</li> <li>■ <b>"dist. unknown"</b> if you do not know the actual distance. This means that the following two functions are skipped.</li> <li>■ <b>"manual"</b> if you want to specify the suppression area yourself in the following function.</li> </ul>

Function	Remarks
"range of mapping" (052)	<p>This function displays the suggested range of mapping. The reference point is always the sensor membrane. This value can be edited by the operator. For manual mapping, the default value is: 0 m.</p> <p> <b>Caution!</b> The suppression range must end 0.5 m (1.6 ft) in front of the echo of the actual level. With an empty tank, do not enter E but E - 0.5 m.</p>
"start mapping" (053)	<p>This function is used to start the interference echo mapping up to the distance given in <b>"range of mapping" (052)</b>.</p> <p><b>Selection:</b></p> <ul style="list-style-type: none"> <li>■ <b>off:</b> no mapping is carried out</li> <li>■ <b>on:</b> mapping is started</li> </ul>
"dist./meas.value" (008)	<p>The distance measured from the reference point to the product surface and the level calculated with the aid of the empty alignment are displayed again. Check whether the values correspond to the actual level or the actual distance.</p> <p>The following cases can occur</p> <ul style="list-style-type: none"> <li>■ Distance correct – level correct -&gt; basic setup completed</li> <li>■ Distance incorrect – level incorrect -&gt; a further interference echo mapping must be carried out <b>"checkdistance" (051)</b>.</li> <li>■ Distance correct – level incorrect -&gt; check <b>"emptycalibr." (005)</b>.</li> </ul>
Return to group selection	<p>After the basic setup, an evaluation of the measurement with the aid of the envelope curve ("display" (09) function group) is recommended.</p> <p>After 3 s, the following message appears</p>

### 5.3.5 Envelope curve with device display

Function	Remarks
"plot settings" (0E1)	<p>After the basic setup, an evaluation of the measurement with the aid of the envelope curve ("<b>envelope curve" (0E)</b> function group) is recommended.</p> <p>Here select which information is displayed in the LCD:</p> <ul style="list-style-type: none"> <li>■ <b>envelope curve</b></li> <li>■ env.curve+FAC</li> <li>■ env.curve+cust.map</li> </ul> <p> <b>Note!</b> The FAC and the interference echo suppression (map) are explained in BA00240F "Prosonic M - Description of Instrument Functions"</p>
"recording curve" (0E2)	<p>This function determines whether the envelope curve is read as</p> <ul style="list-style-type: none"> <li>■ <b>single curve or</b></li> <li>■ <b>cyclic</b></li> </ul> <p> <b>Note!</b> If the envelope curve mode is active on the display, the measured values are updated in a slower cycle time. Thus, it is advisable to leave the envelope curve mode after the measuring point has been optimised.</p>

[www.endress.com/worldwide](http://www.endress.com/worldwide)

---

**Endress+Hauser**   
People for Process Automation

---

KA01062F/00/EN/13.11  
71145350  
CCS/FM+SGML 9.0



71145350