

Brief Operating Instructions

Levelflex FMP56, FMP57

Guided Level-Radar

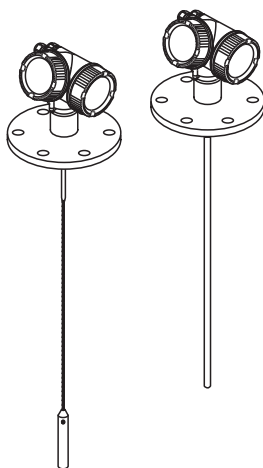

These Instructions are Brief Operating Instructions; they do not replace the Operating Instructions included in the scope of supply.

For detailed information, refer to the Operating Instructions and other documentation on the CD-ROM provided or visit "www.endress.com/deviceviewer".

Table of contents

1	Important document information	3
1.1	Document conventions	3
2	Basic safety instructions	4
2.1	Requirements concerning the staff	4
2.2	Designated use	4
2.3	Workplace safety	5
2.4	Operational safety	5
2.5	Product safety	5
3	Product description	6
3.1	Compact device Levellflex	6
3.2	Electronics housing	7
4	Incoming acceptance and product identification	8
4.1	Incoming acceptance	8
4.2	Product identification	9
5	Storage, Transport	10
5.1	Storage conditions	10
5.2	Transport product to the measuring point	10
6	Mounting	12
6.1	Suitable mounting position	12
6.2	Notes on the process connection	13
6.3	Securing the probe	16
6.4	Special mounting conditions	18
6.5	Mounting the device	18
6.6	Post-installation check	24
7	Electrical connection	25
7.1	Connection options	25
7.2	Connection options	27
7.3	Connection data	28
7.4	Connecting the measuring device	29
7.5	Post-connection check	32
8	Integration into a PROFIBUS network	32
8.1	Overview of the device database files (GSD)	32
8.2	Set device address	33
9	Commissioning via operating menu (On-site display, FieldCare)	35
9.1	Display and operating module	35
9.2	Operating concept	37
9.3	Adjust the display contrast	39
9.4	Unlock the device	39
9.5	Set the operating language	41
9.6	Configuration of a level measurement	42
9.7	User-specific applications (operation)	43





1 Important document information

1.1 Document conventions





1.1.1 Safety symbols

in preparation

1.1.2 Electrical symbols

Symbol	Meaning
 A0011197	Direct current A terminal to which DC voltage is applied or through which direct current flows.
 A0011198	Alternating current A terminal to which alternating voltage (sine-wave) is applied or through which alternating current flows.
 A0011200	Ground connection A grounded terminal which, as far as the operator is concerned, is grounded via a grounding system.
 A0011199	Protective ground connection A terminal which must be connected to ground prior to establishing any other connections.
 A0011201	Equipotential connection A connection that has to be connected to the plant grounding system: This may be a potential equalization line or a star grounding system depending on national or company codes of practice.

1.1.3 Tool symbols

 A0011219	 A0011220	 A0013442	 A0011221	 A0011222
Phillips head screwdriver	Flat blade screwdriver	Torx screwdriver	Allen key	Hexagon wrench

1.1.4 Symbols for certain types of information

in preparation

1.1.5 Symbols in graphics

in preparation

2 Basic safety instructions

2.1 Requirements concerning the staff

The staff must fulfill the following requirements for their tasks:

- ▶ Trained staff: Must have a qualification which corresponds to their function and tasks.
- ▶ Authorized by the plant operator.
- ▶ Familiar with the national regulations.
- ▶ Before starting their work: Must have read and understood all instructions in the operating manual and supplementary documentation as well as the certificate (depending on the application).
- ▶ Must comply with all instructions and the regulatory framework.

2.2 Designated use

Application and measured materials

The measuring device described in these Operating Instructions is intended only for level measurement of bulk solids. Depending on the version ordered the device can also measure potentially explosive, flammable, poisonous and oxidizing materials.

Observing the limit values specified in the "Technical data" and listed in the Operating Instructions and supplementary documentation, the measuring device may be used for the following measurements only:

- ▶ Measured process variables: level
- ▶ Calculated process variables: Volume or mass in arbitrarily shaped vessels (calculated from the level by the linearization functionality)

To ensure that the measuring device remains in proper condition for the operation time:

- ▶ Use the measuring device only for measured materials against which the process-wetted materials are adequately resistant.
- ▶ Observe the limit values in "Technical data".

Incorrect use

The manufacturer is not liable for damage caused by improper or non-designated use.

Verification for borderline cases:

- ▶ For special measured materials and cleaning agents, Endress+Hauser is glad to provide assistance in verifying the corrosion resistance of wetted materials, but does not accept any warranty or liability.

Residual risk

The electronics housing and its built-in components such as display module, main electronics module and I/O electronics module may heat to 80 °C (176 °F) during operation through heat transfer from the process as well as power dissipation within the electronics. During operation the sensor may assume a temperature near the temperature of the measured material.

Danger of burns due to heated surfaces!

- ▶ For high process temperatures: Install protection against contact in order to prevent burns.

2.3 Workplace safety

For work on and with the device:

- ▶ Wear the required personal protective equipment according to federal/national regulations.

2.4 Operational safety

Risk of injury!

- ▶ Operate the device in proper technical condition and fail-safe condition only.
- ▶ The operator is responsible for interference-free operation of the device.

Conversions to the device

Unauthorized modifications to the device are not permitted and can lead to unforeseeable dangers

- ▶ If, despite this, modifications are required, consult with Endress+Hauser.

Repair

To ensure continued operational safety and reliability,

- ▶ Carry out repairs on the device only if they are expressly permitted.
- ▶ Observe federal/national regulations pertaining to repair of an electrical device.
- ▶ Use original spare parts and accessories from Endress+Hauser only.

Hazardous area

To eliminate a danger for persons or for the facility when the device is used in the hazardous area (e.g. explosion protection, pressure vessel safety):

- ▶ Based on the nameplate, check whether the ordered device is permitted for the intended use in the hazardous area.
- ▶ Observe the specifications in the separate supplementary documentation that is an integral part of these Instructions.

2.5 Product safety

This measuring device is designed in accordance with good engineering practice to meet state-of-the-art safety requirements, has been tested, and left the factory in a condition in which they are safe to operate.

It fulfills general safety requirements and legal requirements. It also conforms to the EC directives listed in the device-specific EC declaration of conformity. Endress+Hauser confirms this fact by applying the CE mark.

3 Product description

3.1 Compact device Levelflex

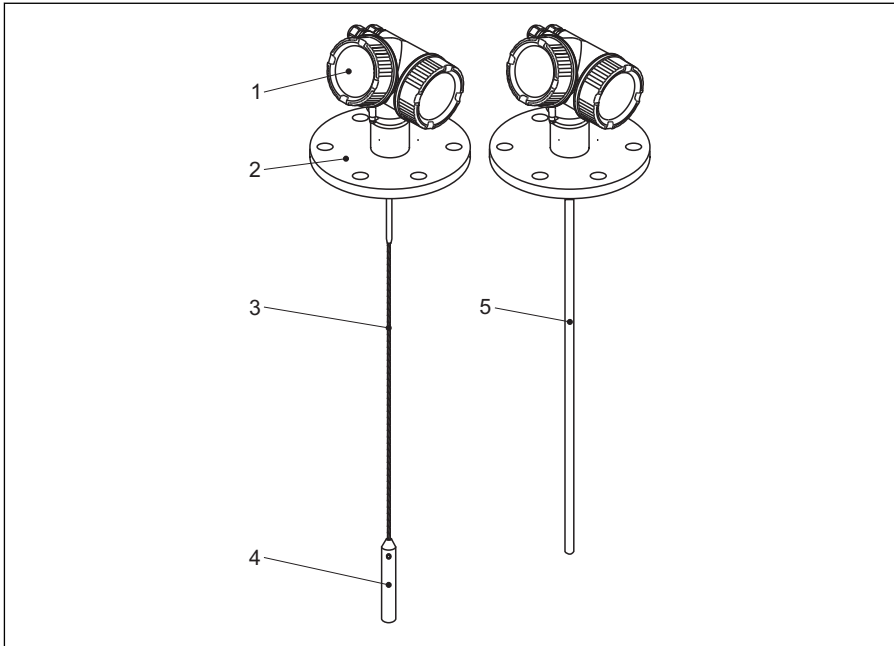

A0012470

1 Design of the Levelflex

- 1 Electronics housing
- 2 Process connection (here as an example: flange)
- 3 Rope probe
- 4 End-of-probe weight
- 5 Rod probe

3.2 Electronics housing

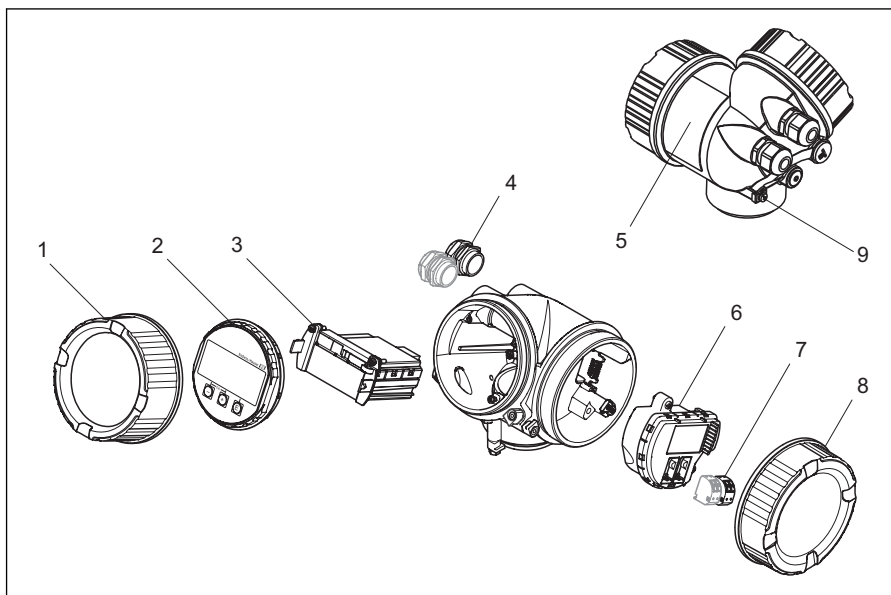

A001242Z

2 Design of the electronics housing

- 1 Electronics compartment cover
- 2 Display module
- 3 Main electronics module
- 4 Cable glands (1 or 2, depending on instrument version)
- 5 Nameplate
- 6 I/O electronics module
- 7 Terminals (pluggable spring terminals)
- 8 Connection compartment cover
- 9 Grounding terminal

4 Incoming acceptance and product identification

4.1 Incoming acceptance

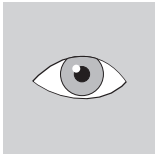

A0013696



1 = 2

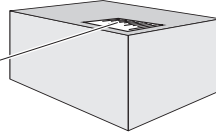

A0016870

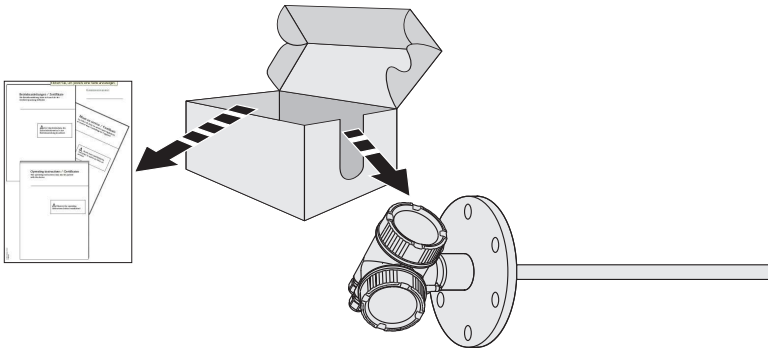

A0013921

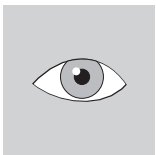

A0013696

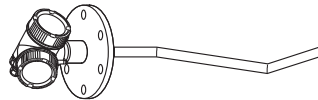
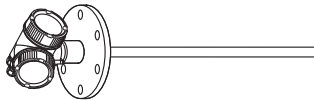

A0013922

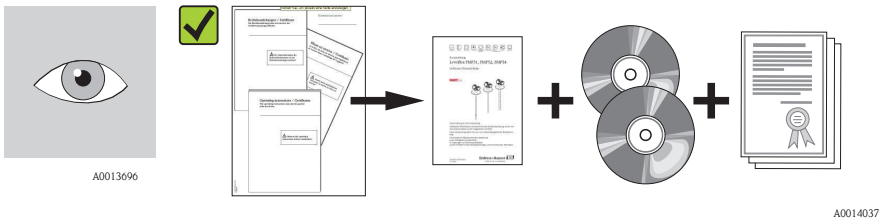
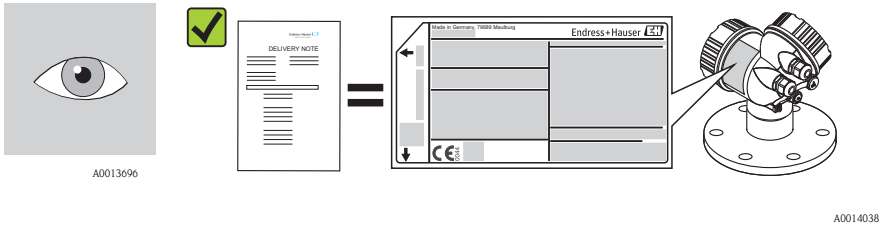

 If one of the conditions does not comply, contact your Endress+Hauser distributor.

4.2 Product identification

The following options are available for identification of the measuring device:

- Nameplate specifications
- Order code with breakdown of the device features on the delivery note
- Enter serial numbers from nameplates in *W@M Device Viewer* (www.endress.com/deviceviewer): All information about the measuring device is displayed.

For an overview of the scope of the Technical Documentation provided, refer to the following:

enter serial numbers from nameplates in *W@M Device Viewer* (www.endress.com/deviceviewer)

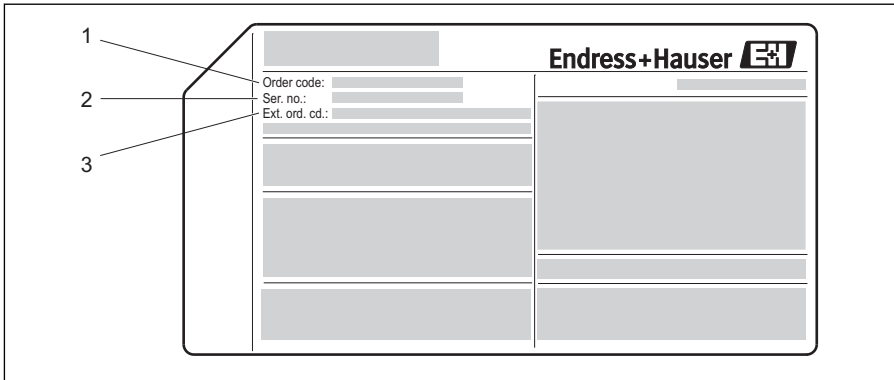

A0014103

 3 Example of a nameplate

- 1 Order code
- 2 Serial number (Ser. no.)
- 3 Extended order code (Ext. ord. cd.)

 Only 33 digits of the extended order code can be indicated on the nameplate. If the extended order code exceeds 33 digits, the rest will not be shown. However, the complete extended order code can be viewed in the operating menu of the device (Diagnostics → Device info → Extended order code 1/2/3).

 For detailed information about interpreting the nameplate specifications, refer to the Operating Instructions for the device on the CD-ROM provided.

5 Storage, Transport

5.1 Storage conditions

- Permitted storage temperature: -40 to $+80$ °C (-40 to $+176$ °F)
- Use the original packaging.

5.2 Transport product to the measuring point

WARNING

Risk of injury if the housing breaks away!

- ▶ Transport the measuring device to the measuring point in its original packaging or at the process connection.
- ▶ Comply with the safety instructions, transport conditions for devices over 18kg (39.6lbs).

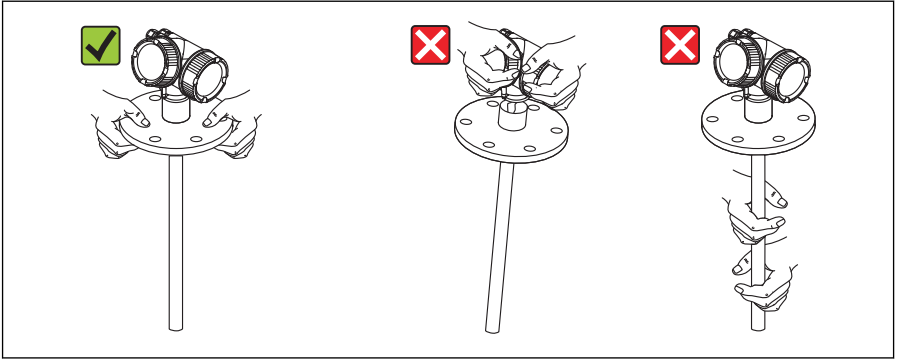

A0013920

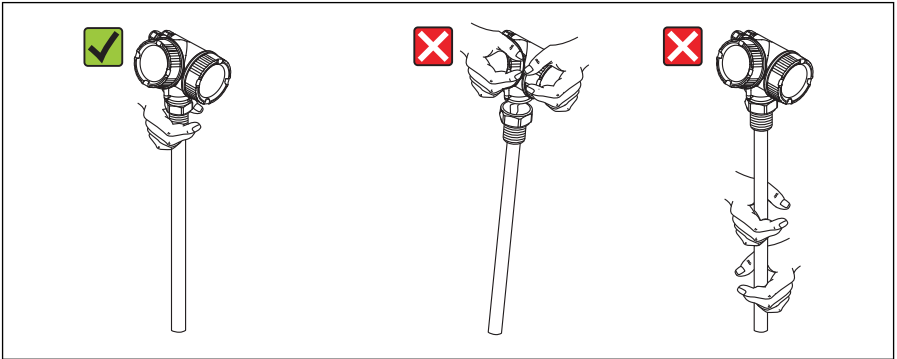

A0014264

6 Mounting

6.1 Suitable mounting position

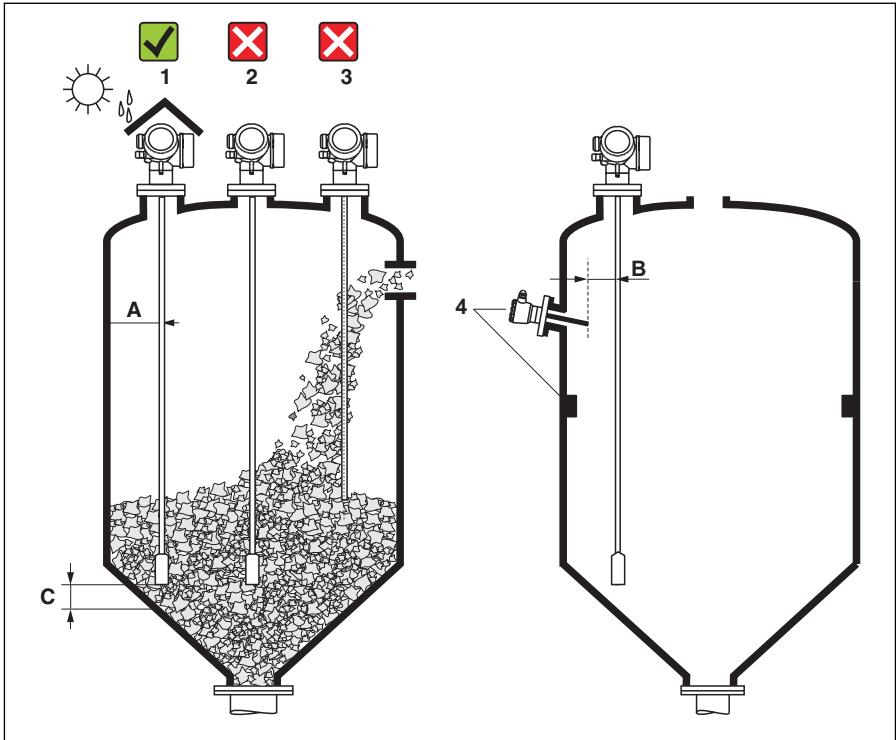

A0012851-EN

6.1.1 Mounting distances

- Distance (A) between wall and rod or rope probe:
 - for smooth metallic walls: > 50 mm (2")
 - for plastic walls: > 300 mm (12") mm to metallic parts outside the vessel
 - for concrete walls: > 500 mm (20") , otherwise the available measuring range may be reduced.
- Distance (B) between rod or rope probe and internal fittings in the vessel: > 300 mm (12")
- Distance (C) from end of probe to bottom of the vessel:
 - Rope probe: > 150 mm (6 in)
 - Rod probe: > 10 mm (0.4 in)

6.1.2 Additional conditions

- When mounting in the open, a weather protection cover (1) may be installed to protect the device against extreme weather conditions.
- In metallic vessels: Preferably do not mount the probe in the center of the vessel (2), as this would lead to increased interference echoes.
If a central mounting position can not be avoided, it is crucial to perform an interference echo suppression(mapping) after the commissioning of the device.
- Do not mount the probe in the filling curtain (3).
- Avoid buckling the rope probe during installation or operation (e.g. through product movement against silo wall) by selecting a suitable mounting location.
- Check the probe regularly for defects.

i With suspended rope probes (probe end not fixed at the bottom) the distance between the probe rope and internal fittings in the tank must not fall below 300 mm (12") during the entire process. A sporadic contact between the probe weight and the cone of the vessel, however, does not influence the measurement as long as the dielectric constant of the medium is at least $DC = 1.8$.

i When mounting the electronics housing into a recess (e.g. in a concrete ceiling), observe a minimum distance of 100 mm (4 inch) between the cover of the terminal compartment / electronics compartment and the wall. Otherwise the connection compartment / electronics compartment is not accessible after installation.

6.2 Notes on the process connection

Probes are mounted to the process connection with threaded connections or flanges. If during this installation there is the danger that the probe end moves so much that it touches the tank floor or cone at times, the probe must, if necessary, be shortened and fixed down (→  16).

6.2.1 Threaded connection

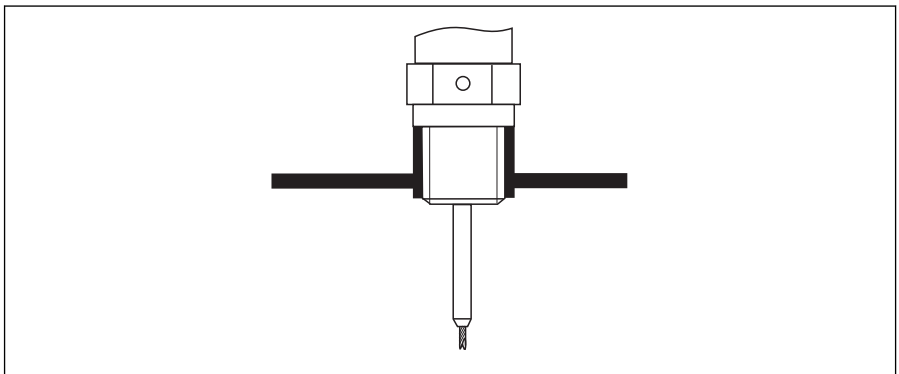

A0015121

 4 *Mounting with threaded connection; flush with the container ceiling*

Seal

The thread as well as the type of seal comply to DIN 3852 Part 1, screwed plug form A.

They can be sealed with the following types of sealing rings:

- Thread G3/4": According to DIN 7603 with the dimensions 27 x 32 mm
- Thread G1-1/2": According to DIN 7603 with the dimensions 48 x 55 mm

Please use a sealing ring according to this standard in the form A, C or D and of a material that is resistant to the application.

i For the length of the screwed plug refer to the dimensional drawing:

- FMP56:
- FMP57:

6.2.2 Nozzle mounting with flange

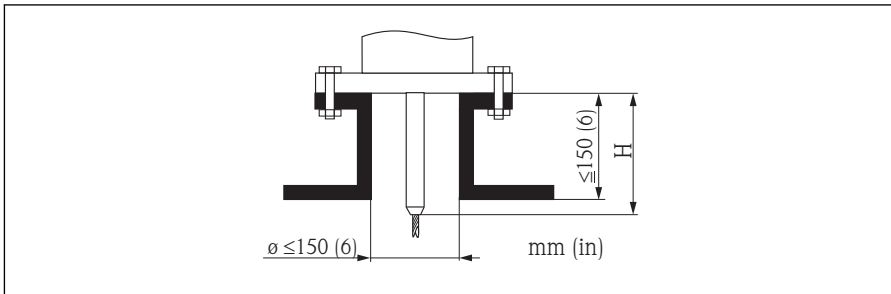

A0015122

Length H of the rigid part of the rope probe

Probe	H
FMP56, \varnothing rope 4 mm (0.16 in)	94 mm (3.7 in)
FMP57, \varnothing rope 4 mm (0.16 in)	120 mm (4.7 in)
FMP57, \varnothing rope 6 mm (0.24 in)	135 mm (5.3 in)

Hight and diameter of the nozzle

- Permissible nozzle diameter: ≤ 150 mm (6 in).
For larger diameters the near range measuring capability may be reduced.
For nozzles \ge DN300: (\rightarrow 15).
- Permissible nozzle height¹⁾: ≤ 150 mm (6 in).
For a larger height the near range measuring capability may be reduced.
Larger nozzle heights may be possible in special cases (see section "Rod extension/centering HMP40 for FMP57").

1) Larger nozzle heights on request

i With thermally insulated vessels the nozzle should also be insulated in order to prevent condensate formation.

Rod extension/centering HMP40 for FMP57

For FMP57 with rope probes the rod extension/centering HMP 40 is available as an accessory (*Verweisziel existiert nicht, aber @y.link.required='true'*). It has to be used if otherwise the probe rope comes into contact with the lower edge of the nozzle.

i This accessory consists of the extension rod corresponding to the nozzle height, on which a centering disk is also mounted if the nozzles are narrow or when working in bulk solids. This component is delivered separately from the device. Please order the probe length correspondingly shorter.

Centering disks with small diameters (DN40 and DN50) may only be used if there is no significant build-up in the nozzle above the disk. The nozzle must not become clogged by the product.

Installation in nozzles \geq DN300

If installation in \geq 300mm/12" nozzles is unavoidable, installation must be carried out in accordance with the sketch on the right.

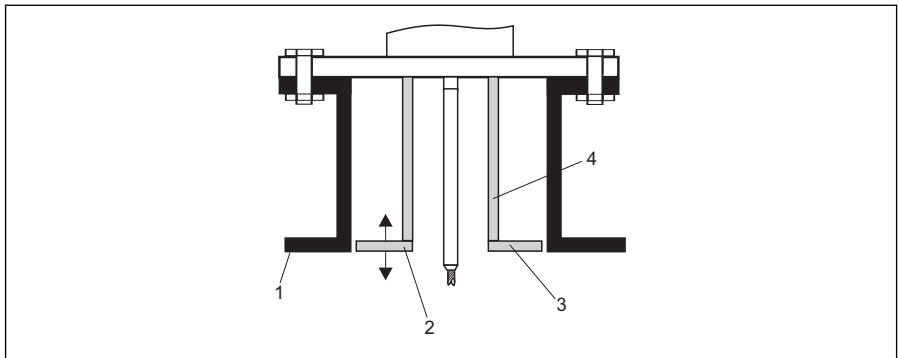

A0014199

- 1 Lower edge of the nozzle
- 2 Approx. flush with the lower edge of the nozzle (\pm 50 mm/2")
- 3 Plate
- 4 Pipe \varnothing 150 to 180 mm (6 to 7 inch)

Nozzle diameter	Plate diameter
300 mm (12")	280 mm (11")
\geq 400 mm (16")	\geq 350 mm (14")

6.3 Securing the probe

6.3.1 Securing rope probes

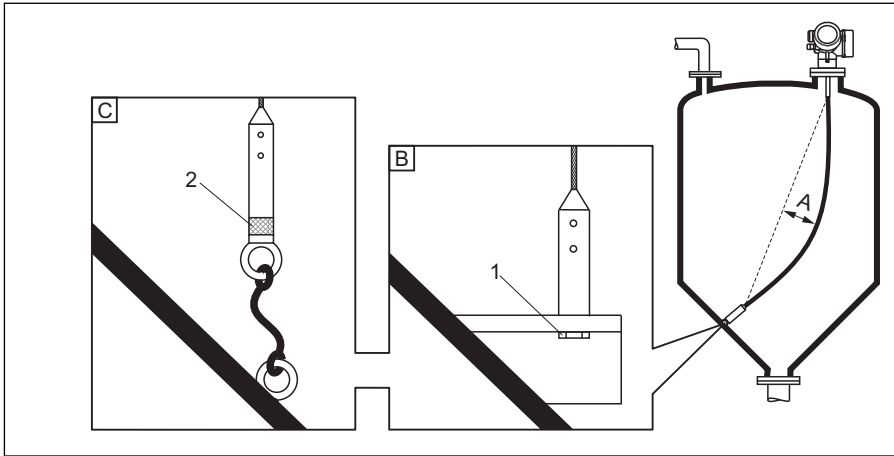

A0012609

A Sag of the rope: ≥ 1 cm per 1 m of the probe length (0.12 inch per 1 ft of the probe length)

B Reliably grounded end of probe

C Reliably isolated end of probe

1: Mounting and contact with a bolt

2 Mounting kit isolated

- The end of the probe needs to be secured under the following conditions:
 - if otherwise the probe sporadically comes into contact with the wall of the vessel, the outlet cone, internal fittings or other parts of the installation.
 - if otherwise the probe sporadically gets close to a concrete wall (minimum distance 0.5 m / 20 inch).
- The end of probe can be secured at its internal thread
 - rope 4 mm (1/6"), 316: M 14
 - rope 6 mm (1/4"), 316: M 20
 - rope 6mm (1/4"), PA>steel: M14
 - rope 8mm (1/3"), PA>steel: M20
- Preferably use the 6 mm (1/4") rope probe due to the higher tensile strength when fixing a rope probe.
- The fixing must be either reliably grounded or reliably insulated. If it is not possible to mount the probe weight with a reliably insulated connection, it can be secured using an isolated eyelet, which is available as an accessory .
- In order to prevent an extremely high tensile load (e.g. due to thermal expansion) and the risk of rope crack, the rope has to be slack. Make the rope longer than the required measuring range such that there is a sag in the middle of the rope that is ≥ 1 cm/(1 m rope length) [0.12 inch/(1 ft rope length)]. Tensile load limit of rope probes: [\(Verweisziel existiert nicht, aber @y.link.required='true'\)](#)

6.3.2 Securing rod probes

- For Ex-approvals: For probe lengths ≥ 3 m (10 ft) a support is required.
- In general, rod probes must be supported if there is a horizontal flow (e.g. from an agitator) or in the case of strong vibrations.
- Rod probes may only be supported at the end of the probe.

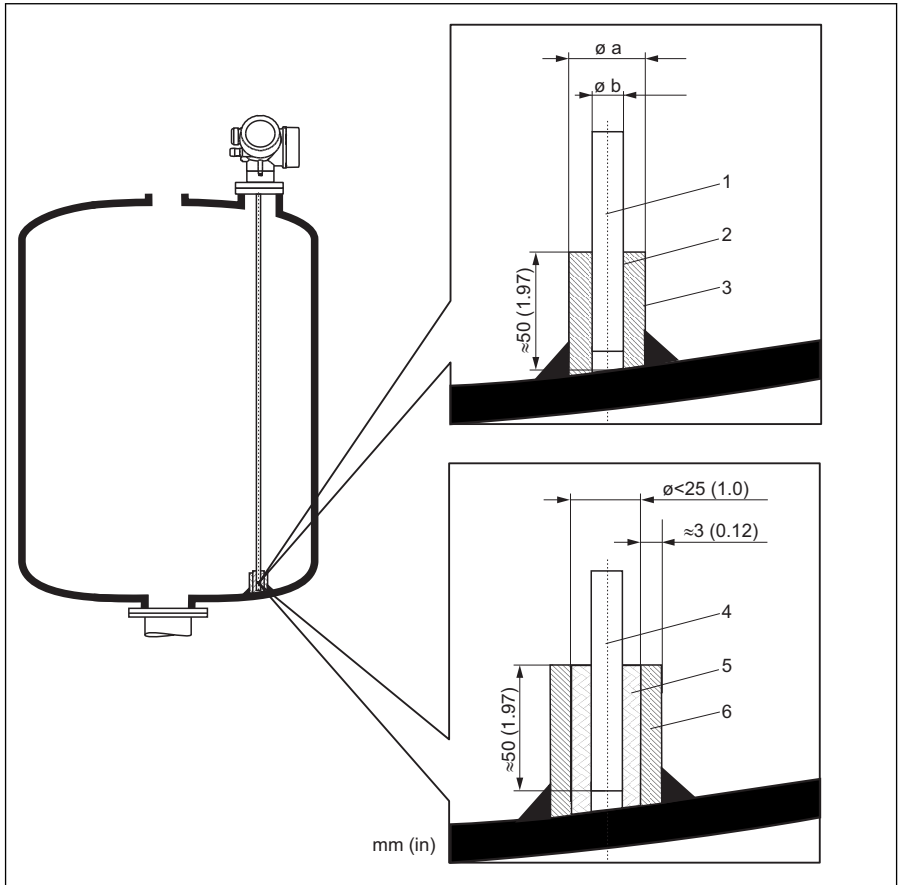

A0012607

- 1 Probe rod, uncoated
- 2 Sleeve bored tight to ensure electrical contact between the rod and sleeve!
- 3 Short metal pipe, e.g. welded in place
- 4 Probe rod, coated
- 5 Plastic sleeve, e.g. PTFE, PEEK or PPS
- 6 Short metal pipe, e.g. welded in place

NOTICE

Poor grounding of the end of probe may cause measuring errors.

- ▶ Apply a narrow sleeve which has good electrical contact to the probe.

NOTICE

Welding may damage the main electronics module.

- ▶ Before welding: Ground the probe and dismount electronics.

6.4 Special mounting conditions

6.4.1 Non-metallic vessels

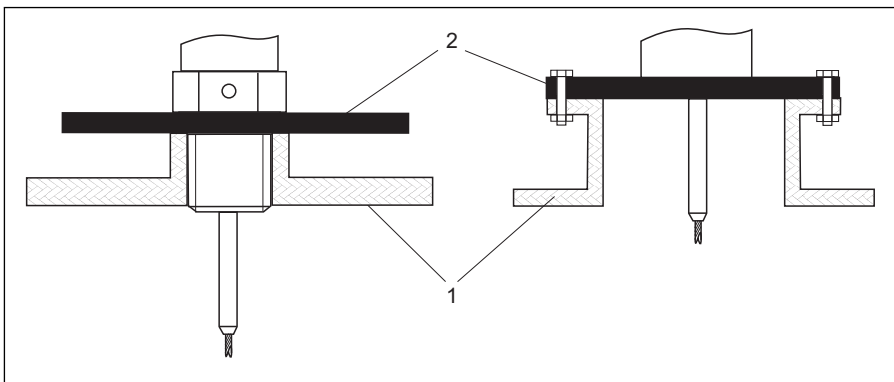

A0012527

1 *Non-metallic vessel*

2 *Metal sheet or metal flange*

To measure, Levelflex with a rod probe needs a metallic surface at the process connection. Therefore:

- Select an instrument version with metal flange (minimum size DN50/2").
- Or: mount a metal sheet with a diameter of at least 200 mm (8") to the probe at the process connection. Its orientation must be perpendicular to the probe.

6.5 Mounting the device

6.5.1 Required mounting tools

- For mounting thread 3/4": Hexagonal wrench 36 mm
- For mounting thread 1-1/2": Hexagonal wrench 55 mm
- To shorten rod or coax probes: Saw

- To shorten rope probes:
 - Allen key AF 3 mm (for 4mm ropes) or AF 4 mm (for 6 mm ropes)
 - Saw or bolt cutter
- For flanges and other process connections: appropriate mounting tools
- To turn the housing: Hexagonal wrench 8 mm

6.5.2 Preparing the device for mounting



When shortening the probe: Enter the new length of probe into the Quick Setup which can be found in the electronics housing behind the display module.

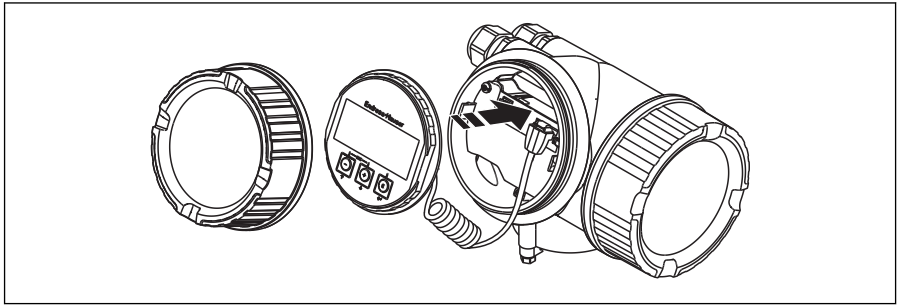

A0014241

Shortening rod probes

Rod probes must be shortened if the distance to the container floor or outlet cone is less than 10 mm (0.4 in). The rods of a rod probe are shortened by sawing at the bottom end.



Rod probes of FMP52 can **not** be shortened as they are coated.

Shortening rope probes

Rope probes must be shortened if the distance to the container floor or outlet cone is less than 150 mm (6 in).



Rope probes of FMP52 can **not** be shortened as they are coated.

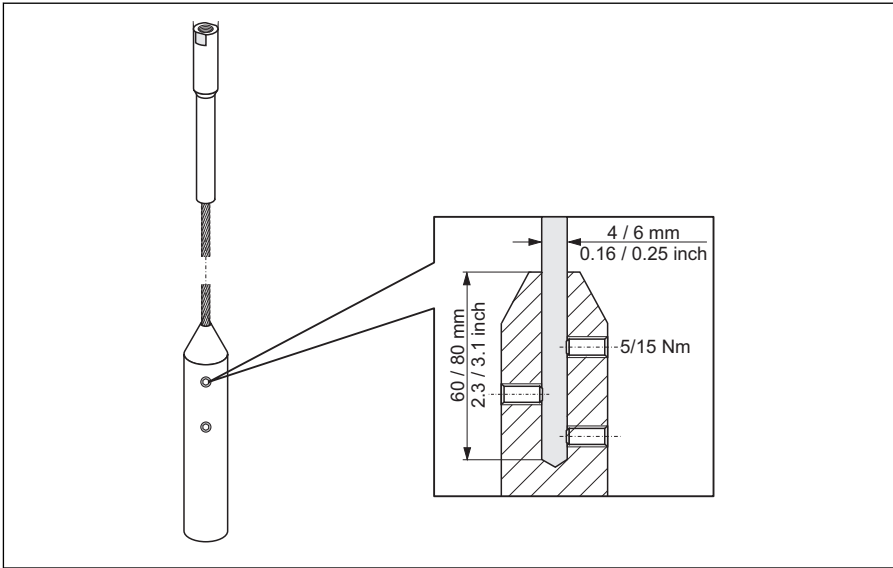

A0012453

1. Loosen the 3 Allen set screws using an Allen key AF3 (for 4mm ropes) or AF4 (for 6 mm ropes). Note: The set screws have got a clamping coating in order to prevent accidental loosening. Thus an increased torque might be necessary to loosen them.
2. Remove released rope from the weight.
3. Measure off new rope length.
4. Wrap adhesive tape around the rope at the point to be shortened to prevent it from fanning out.
5. Saw off the rope at a right angle or cut it off with a bolt cutter.
6. Insert the rope completely into the weight: rope 4 mm (0.16 in): 60 mm (2.4 in) deep; rope 6 mm (0.24 in): 80 mm (3.2 in) deep.
7. Screw the set screws into place. Due to the clamping coating of the setscrews application of a screw locking fluid is not necessary. Torque: rope 4 mm (0.16 in): 5 Nm (3.7 lbf ft); rope 6 mm (0.24 in): 15 Nm (11 lbf ft).

6.5.3 Mounting the device

Mounting devices with thread

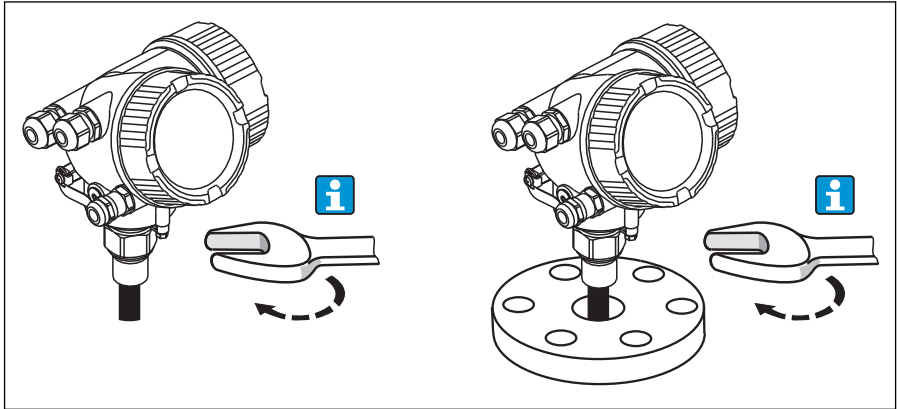

A0012528

Devices with mounting thread are screwed into a welding boss or a flange and are usually also secured with these.

- i** ■ Tighten with the hexagonal nut only:
 - Thread 3/4": Hexagonal wrench 36 mm
 - Thread 1-1/2": Hexagonal wrench 55 mm
- Maximum permissible torque:
 - Thread 3/4": 45 Nm
 - Thread 1-1/2": 450 Nm
- Recommended torque when using the supplied aramid fibre seal and a process pressure of 40 bar (580 psi):
 - Thread 3/4": 25 Nm
 - Thread 1-1/2": 140 Nm
- When installing in metal containers, take care to ensure good metallic contact between the process connection and container.

Flange mounting

If a seal is used, be sure to use unpainted metal bolts to ensure good electrical contact between probe flange and process flange.

Mounting rope probes

NOTICE

Electrostatic discharges may damage the electronics.

- ▶ Earth the housing before lowering the rope into the vessel.

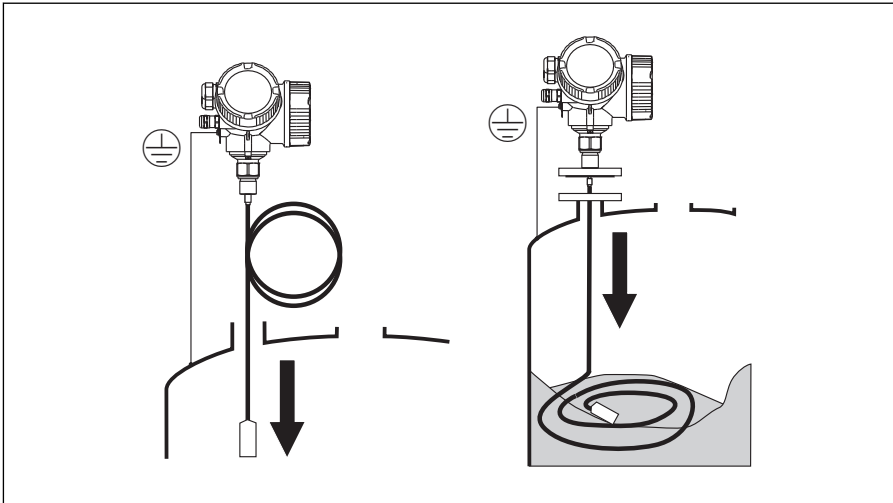

A0012529

When lowering the rope probe into the vessel, observe the following:

- Uncoil rope and lower it slowly and carefully into the vessel.
- Do not kink the rope.
- Avoid any backlash, since this might damage the probe or the vessel fittings.

i Mounting rope probes in a partially full silo

It is not always possible to empty a silo which is already in operation. If a minimum of 2/3 of the silo is empty, it is possible to install the probe into the partially filled silo. If possible, make a visual check after the installation to see that the rope has not tangled or is lying such that it can knot when the level falls. Before full accuracy is obtained the probe rope must hang fully extended.

6.5.4 Turning the transmitter housing

To provide easier access to the connection compartment or display module, the transmitter housing can be turned:

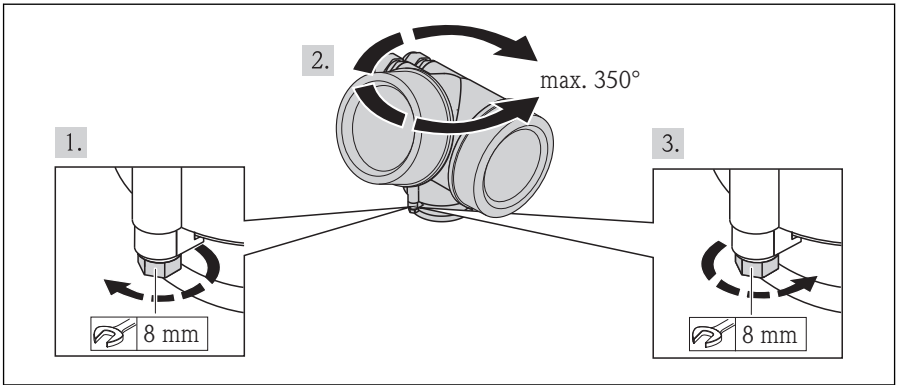

A0013713

1. Unscrew the securing screw using an open-ended wrench.
2. Rotate the housing in the desired direction.
3. Firmly tighten the securing screw. (1,5 Nm for plastics housing; 2,5 Nm for aluminium or stainless steel housing).

6.5.5 Turning the display module

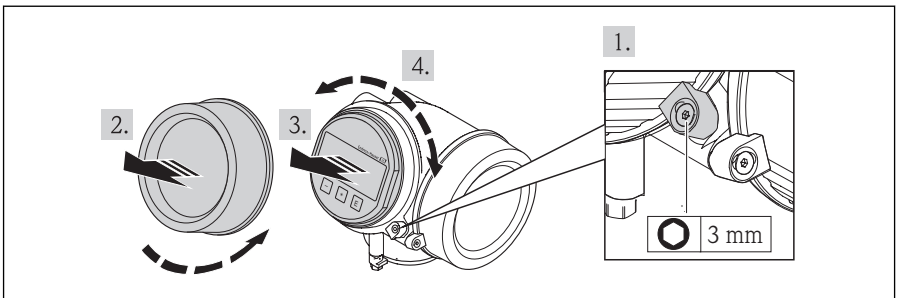

A0013905

1. Loosen the screw of the securing clamp of the electronics compartment cover using an Allen key and turn the clamp 90° counterclockwise.
2. Unscrew cover of the electronics compartment from the transmitter housing.
3. Pull out the display module with a gentle rotation movement.
4. Rotate the display module into the desired position: Max. $8 \times 45^\circ$ in each direction.
5. Feed the spiral cable into the gap between the housing and main electronics module and plug the display module into the electronics compartment until it engages.
6. Screw the cover of the electronics compartment firmly back onto the transmitter housing.

- 7. Tighten the securing clamp again using the Allen key.

6.6 Post-installation check

<input type="radio"/>	Is the device undamaged (visual inspection)?
<input type="radio"/>	Does the device conform to the measuring point specifications? For example: <ul style="list-style-type: none"> ■ Process temperature ■ Process pressure (refer to the chapter on "Material load curves" of the "Technical Information" document) ■ Ambient temperature range ■ Measuring range
<input type="radio"/>	Are the measuring point identification and labeling correct (visual inspection)?
<input type="radio"/>	Is the device adequately protected from precipitation and direct sunlight?
<input type="radio"/>	Are the securing screw and securing clamp tightened securely?

7 Electrical connection

7.1 Connection options

7.1.1 Connection options

PROFIBUS PA / FOUNDATION Fieldbus

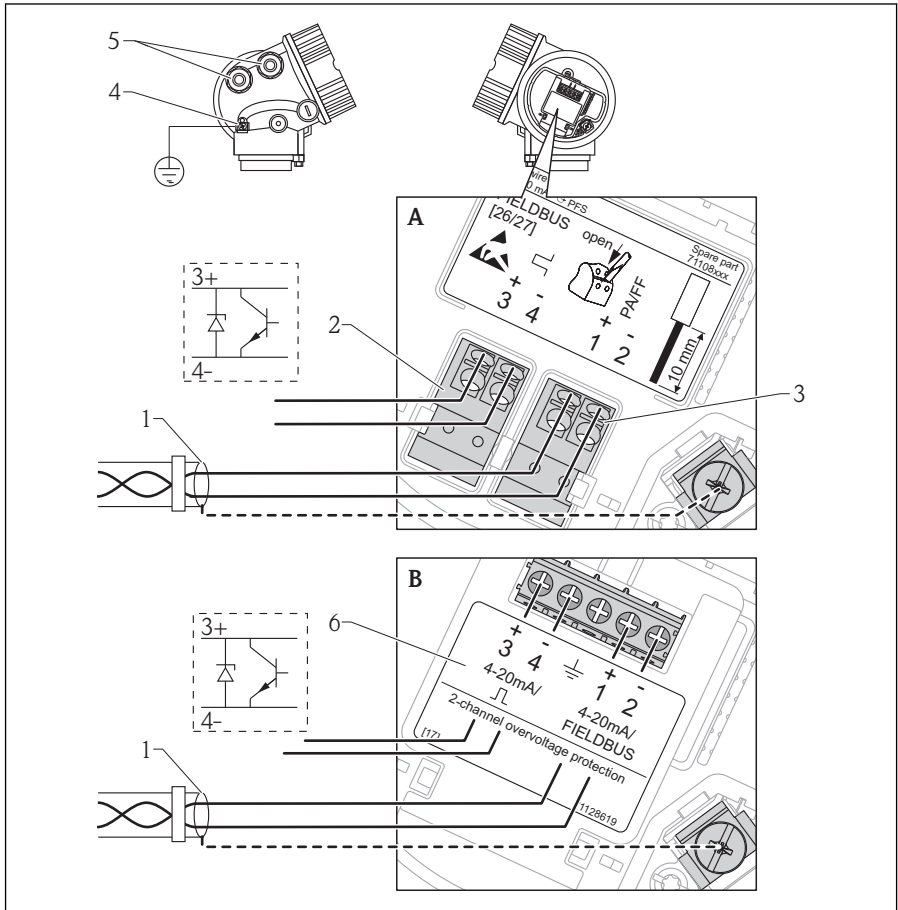

A0011341

5 Terminal assignment PROFIBUS PA / FOUNDATION Fieldbus

- A Without integrated overvoltage protection
- B With integrated overvoltage protection
- 1 Cable screen: Observe cable specifications (→ 27)
- 2 Terminals for switch output (open collector)
- 3 Terminals PROFIBUS PA / FOUNDATION Fieldbus

- 4 *Terminal for potential equalization line*
- 5 *Cable entries*
- 6 *Overvoltage protection module*

Connection examples for the switch output

i For HART devices, the switch output is available as an option. See product structure, feature 20: "Power Supply, Output", option B: "2-wire; 4-20mA HART, switch output"

Devices with PROFIBUS PA and FOUNDATION Fieldbus always have a switch output.

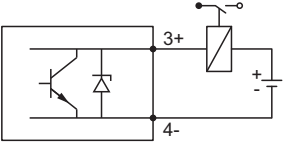
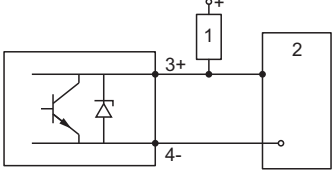
 <p style="text-align: right; font-size: small;">A0015909</p> <p>6 <i>Connection of a relay</i></p> <p>Suitable relays (examples):</p> <ul style="list-style-type: none"> ■ Solid-state relay: Phoenix Contact OV-24DC/480AC/5 with mounting rail connector UMK-1 OM-R/AMS ■ Electromechanical relay: Phoenix Contact PLC-RSC-12DC/21 	 <p style="text-align: right; font-size: small;">A0015910</p> <p>7 <i>Connection of a digital input</i></p> <p>1 <i>Pull-up resistor</i> 2 <i>Digital input</i></p>
--	--

7.2 Connection options

7.2.1 Cable specification

PROFIBUS

Use a twisted, screened two-wire cable, preferably cable type A.

i For further information on the cable specifications, see Operating Instructions BA00034S "Guidelines for planning and commissioning PROFIBUS DP/PA", PNO Guideline 2.092 "PROFIBUS PA User and Installation Guideline" and IEC61158-2 (MBP).

7.2.2 Cable diameter and cross-section of the strands

Type of protection	Cable gland	Admissible cable diameter	Admissible cross-section of the strands
<ul style="list-style-type: none"> ■ Standard ■ Ex ia ■ Ex ic 	Plastics M20x1,5	5 to 10 mm (0.2 to 0.39 in)	0.5 to 2.5 mm ² (20 to 14 AWG)
<ul style="list-style-type: none"> ■ Ex tD ■ Ex nA ■ FM approval ■ CSA approval 	Metal M20x1.5	7 to 10 mm (0.28 to 0.39 in)	

7.2.3 Overvoltage protection

If the measuring device is used for level measurement in flammable liquids which requires the use of overvoltage protection according to DIN EN 60079-14, standard for test procedures 60060-1 (10 kA, pulse 8/20 μ s), overvoltage protection has to be ensured by an integrated or external overvoltage protection module.

Integrated overvoltage protection

An integrated overvoltage protection module is available for 2-wire HART as well as PROFIBUS PA and FOUNDATION Fieldbus devices.

Product structure: Feature 610 "Accessory mounted", option NA "Overvoltage protection".

Technical data	
Resistance per channel	2 * 0.5 Ω max
Threshold DC voltage	400 to 700 V
Threshold impulse voltage	< 800 V
Capacitance at 1 MHz	< 1.5 pF
Nominal arrest impulse voltage (8/20 μ s)	10 kA

External overvoltage protection

HAW562 or HAW569 from Endress+Hauser are suited as external overvoltage protection.



For detailed information please refer to the following documents:

- HAW562: TI01012K
- HAW569: TI01013K

7.3 Connection data

7.3.1 PROFIBUS PA

"Power supply; Output" ¹⁾	Terminal voltage
G: 2-wire; PROFIBUS PA, switch output	9 to 32 V _{DC}

1) Feature 020 of the product structure

7.4 Connecting the measuring device

⚠ WARNING

Explosion hazard!

- ▶ Comply with the relevant national standards.
- ▶ Observe the specifications in the Safety Instructions (XA).
- ▶ Only use the specified cable glands.
- ▶ Check whether the supply voltage matches the specifications on the nameplate.
- ▶ Before connecting the device: Switch the supply voltage off.
- ▶ Before switching on the supply voltage: Connect the potential bonding line to the exterior ground terminal.

Required tools and accessories:

- For instruments with safety pin for the lid: AF 3 Allen key
- Wire stripping pliers
- When using stranded wires: Wire end sleeves.

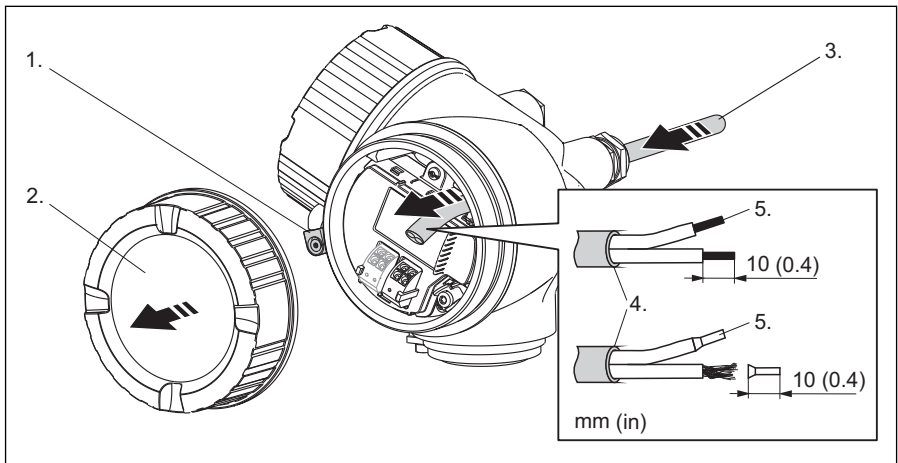

A0012619

1. Loosen the screw of the securing clamp of the connection compartment cover and turn the clamp 90° counterclockwise.
2. Unscrew the connection compartment cover.
3. Push the cable through the cable entry. To ensure tight sealing, do not remove the sealing ring from the cable entry.
4. Strip the cable.
5. Strip the cable ends 10 mm (0.4 in). For stranded cables, also attach wire end ferrules.
6. Firmly tighten the cable glands.

7.

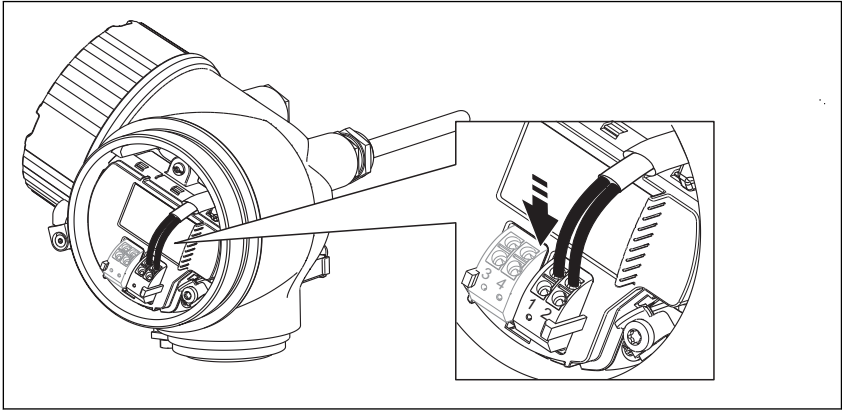

A0013837

Connect the cable in accordance with the terminal assignment (→ 25).

8. When using screened cable: Connect the cable screen to the ground terminal.
9. Screw the cover onto the connection compartment.
10. For instruments with safety pin for the lid: Adjust the safety pin so that its edge is over the edge of the display lid. Tighten the safety pin.





Pluggable spring-force terminals

Instruments without integrated overvoltage protection have pluggable spring-force terminals. Rigid or flexible conductors with or without cable sleeve can directly be inserted and are contacted automatically.

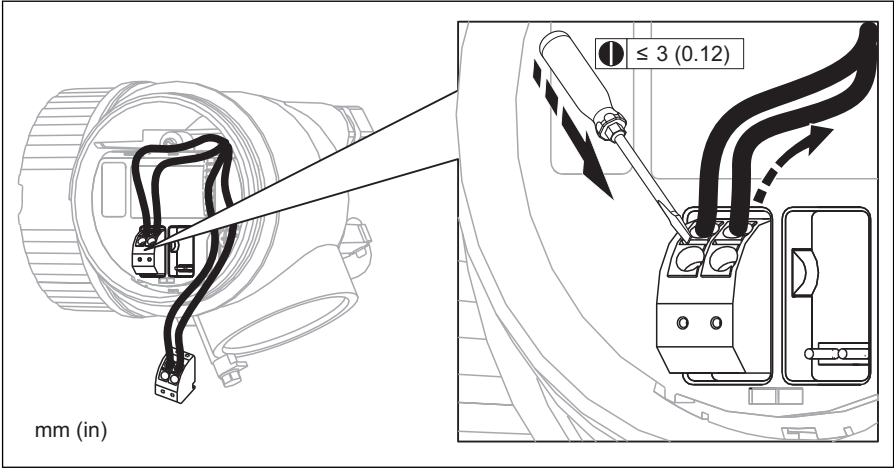
To remove cables from the terminal: Press on the groove between the terminals using a flat-tip screwdriver ≤ 3 mm (0.12 inch) while pulling the cables out of the terminals.



7.5 Post-connection check

<input type="radio"/>	Are cables or the device undamaged (visual inspection)?
<input type="radio"/>	Do the cables comply with the requirements?
<input type="radio"/>	Do the cables have adequate strain relief?
<input type="radio"/>	Are all cable glands installed, firmly tightened and correctly sealed?
<input type="radio"/>	Does the supply voltage match the specifications on the transmitter nameplate?
<input type="radio"/>	Is the terminal assignment correct (→  25)?
<input type="radio"/>	If required: Is the protective earth connected correctly (→  25)?
<input type="radio"/>	If supply voltage is present: Is the device ready for operation and do values appear on the display module?
<input type="radio"/>	Are all housing covers installed and firmly tightened?
<input type="radio"/>	Is the securing clamp tightened correctly?

8 Integration into a PROFIBUS network

8.1 Overview of the device database files (GSD)

Manufacturer ID	17 (0x11)
Ident number	0x1558
Profile version	3.02
GSD file	Information and files under:
GSD file version	<ul style="list-style-type: none"> ■ www.endress.com ■ www.profibus.org

8.2 Set device address

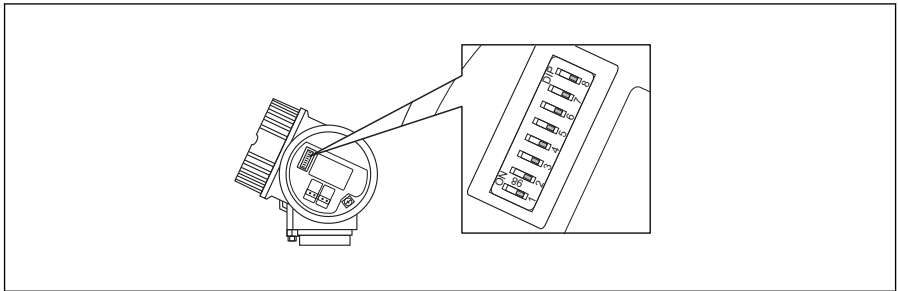

A0015686

 8 Address switches in terminal compartment

8.2.1 Hardware addressing

1. Set switch 8 to "OFF".
2. Define the address with switches 1 to 7 according to the table below.

The address change becomes effective after 10 seconds. The device restarts automatically.

Switch	1	2	3	4	5	6	7
Value in position "ON"	1	2	4	8	16	32	64
Value in position "OFF"	0	0	0	0	0	0	0

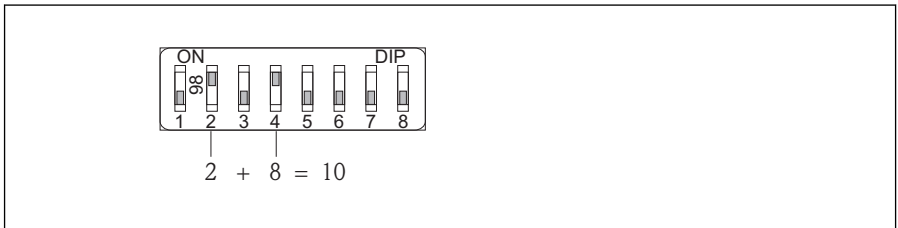

A0015902

 9 Example of hardware addressing: switch 8 is in position "OFF"; switches 1 to 7 define the address.

8.2.2 Software addressing

1. Set switch 8 to "ON".
2. The device restarts automatically. The address remains the same as before (factory setting: 126).
3. Set the required address via the operating menu: Setup → Device address

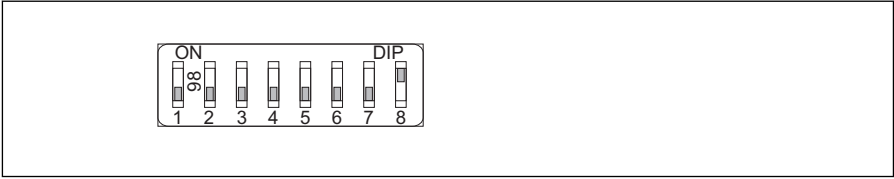

A0015903

- 10 Example of software addressing; switch 8 is in position "ON"; the address is defined in the operating menu (Setup → Device address)

9 Commissioning via operating menu (On-site display, FieldCare)

9.1 Display and operating module

9.1.1 Display appearance

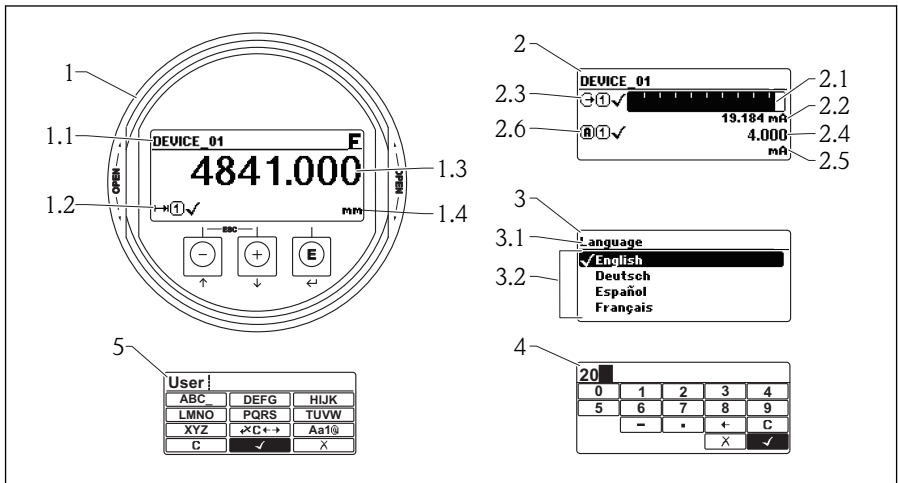









A0012635

11 Appearance of the display and operation module for on-site operation

- 1 Measured value display (1 value max. size)
- 1.1 Header containing tag and error symbol (if an error is active)
- 1.2 Measured value symbols
- 1.3 Measured value
- 1.4 Unit
- 2 Measured value display (2 values)
- 2.1 Bargraph for measured value 1
- 2.2 Measured value 1 (including unit)
- 2.3 Measured value symbols for measured value 1
- 2.4 Measured value 2
- 2.5 Unit for measured value 2
- 2.6 Measured value symbols for measured value 2
- 3 Representation of a parameter (here: a parameter with selection list)
- 3.1 Header containing parameter name and error symbol (if an error is active)
- 3.2 Selection list; ✓ marks the current parameter value.
- 4 Input matrix for numbers
- 5 Input matrix for alphanumeric and special characters

9.1.2 Navigation and selection from a list

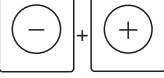
Use the operating keys to navigate within the operating menu and to select options from a list.

Key	Meaning
 <small>A0011971</small>	<p>"Minus" key</p> <p>Henceforth represented by .</p> <ul style="list-style-type: none"> ■ In a selection list: Moves the selection bar upward. ■ In an input matrix: Moves the selection bar backward.
 <small>A0011972</small>	<p>"Plus" key</p> <p>Henceforth represented by .</p> <ul style="list-style-type: none"> ■ In a selection list: Moves the selection bar downward. ■ In an input matrix: Moves the selection bar forward.
 <small>A0011973</small>	<p>"Enter" key</p> <p>Henceforth represented by .</p> <ul style="list-style-type: none"> ■ Opens the marked submenu or parameter. ■ Confirms a changed parameter value.
 <small>A0012661</small>	<p>"Escape" key combination (press keys simultaneously)</p> <p>Henceforth represented by  + .</p> <ul style="list-style-type: none"> ■ Closes a parameter without accepting the changes. ■ Quits the current menu layer and returns to the next higher layer.

9.2 Operating concept

9.2.1 Structure

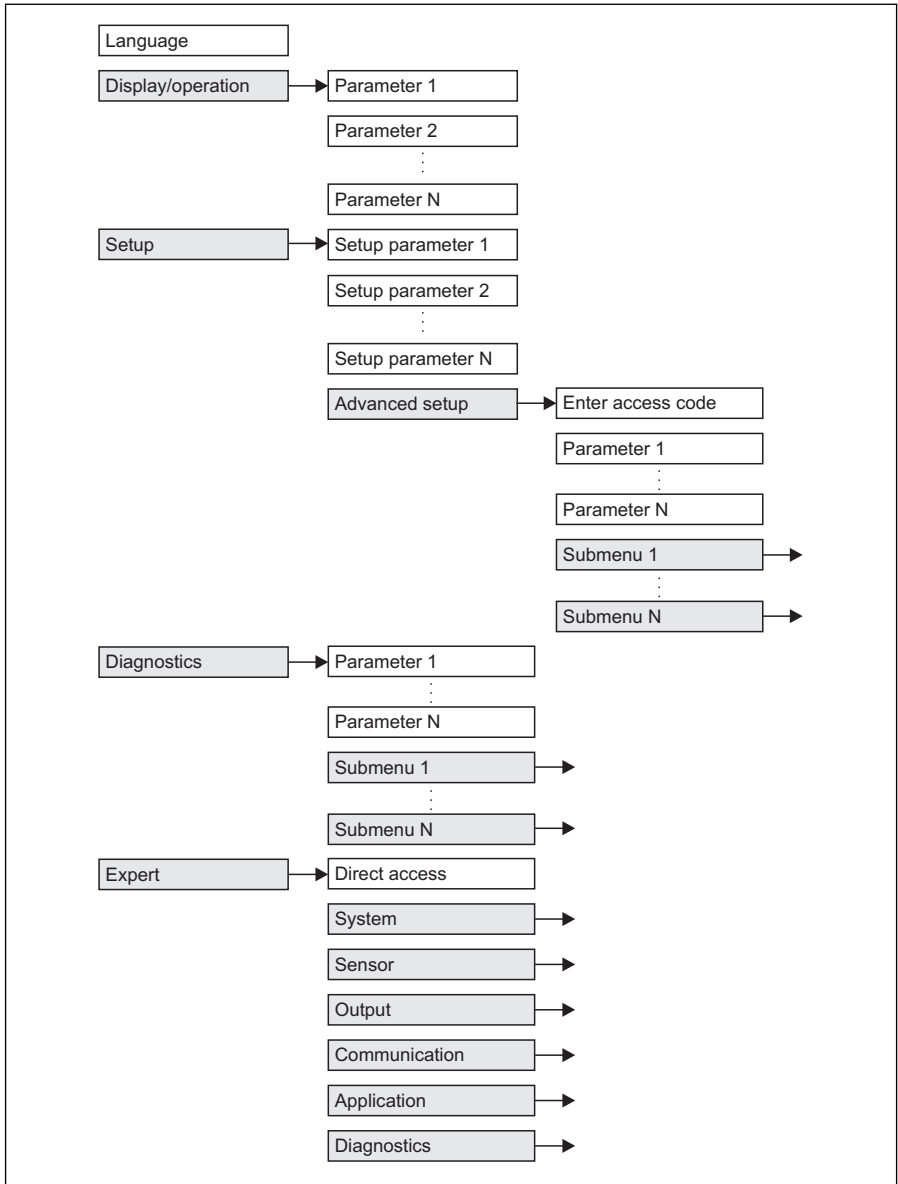



A0011407-EN

 12 Basic structure of the operating menu; gray: submenus; white: parameters

9.2.2 Submenus and user roles

The submenus are designed for different user roles. A user role is defined by typical tasks within the lifecycle of the device.

User role	Typical tasks	Submenu
Operator	Tasks in the ongoing process: <ul style="list-style-type: none"> ■ Configuration of the display. ■ Reading measuring values. 	"Language" Defines the operating language (→  41).
		"Display/Operation" Contains all parameters which are needed during the ongoing process: configuration of the display (display values, display format, display contrast ...).
Maintenance	Commissioning: <ul style="list-style-type: none"> ■ Configuration of the measurement. ■ Configuration of the measured value processing (scaling, linearization, limit detection etc.). ■ Configuration of the measured value output (analog and digital communication interface). 	"Setup" Contains all commissioning parameters (→  42).
	Error handling	"Diagnostics" Contains all parameters needed to detect and analyze operational errors.
Expert	Tasks which require detailed knowledge about the instrument: <ul style="list-style-type: none"> ■ Commissioning of measurements under demanding conditions. ■ Optimization of the measurement under demanding conditions. ■ Detailed configuration of the communication interface. ■ Error diagnosis in difficult cases. 	"Expert"

9.3 Adjust the display contrast

- + (pressed simultaneously): increases the contrast.
- + (pressed simultaneously): decreases the contrast.

9.4 Unlock the device

If the device has been locked, it must be unlocked before the measurement can be configured.

9.4.1 Revoke hardware locking

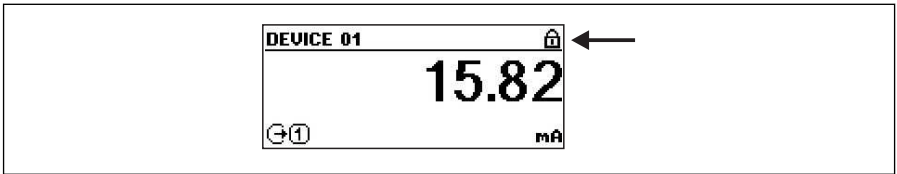

A0013649

13 Measured value screen of a hardware-locked device

The padlock in the header of the measured value screen indicates that the device is hardware-locked. In order to unlock the device, shift the locking switch (which is located below the display module) into the "unlocked" position.

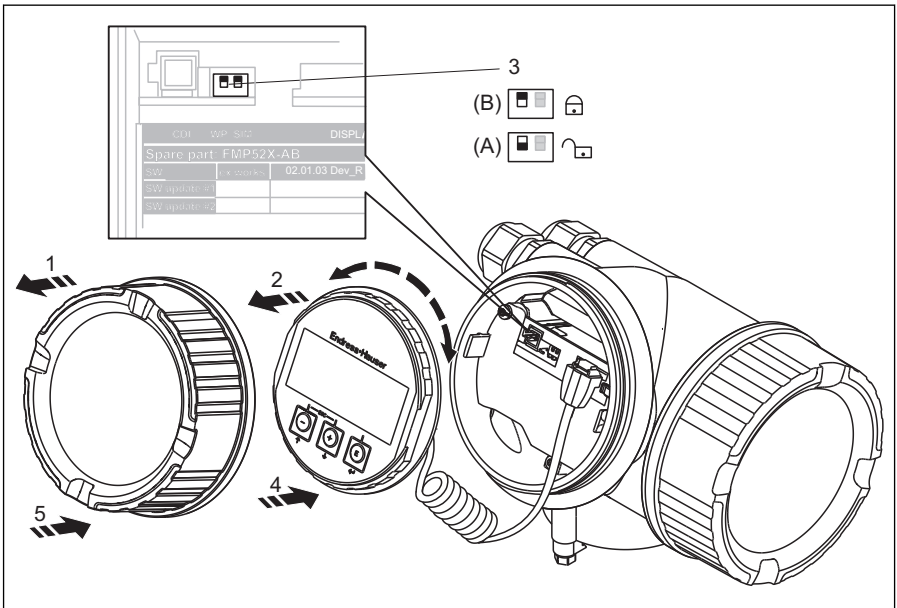

A0013132

1. Unscrew the lid from the compartment for the display and operating module.
2. Slightly turn the display and operating module to remove it from the compartment.
3. Set the locking switch (WP: Write Protection) into the desired position. (A): unlocked; (B): locked.
4. Attach the display and operating module in the desired orientation until it closes with a snap.
5. Screw the lid onto the compartment.

9.4.2 Revoke software locking

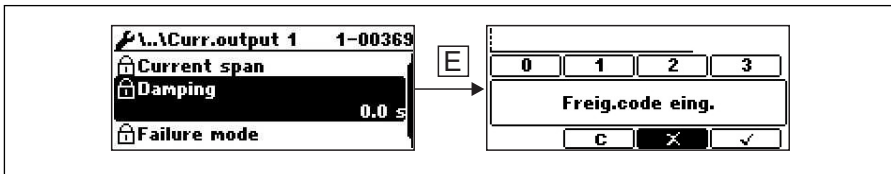

A0013651

14 Input prompt for the access code to unlock software-locked parameters.

Parameters affected by the software lock are marked by a padlock in front of the parameter name. After pressing **E** an input prompt appears. Enter the user defined locking code to unlock the device.

Step	Parameter	Action
1	Setup → Advanced setup → Define access code	To lock the device: Enter a user-defined access code.
2	Setup → Advanced setup → Enter access code	To unlock the device: Enter the previously defined access code.
3	Setup → Advanced setup → Enter access code	To lock the device again: Enter a number other than the previously defined access code.

9.5 Set the operating language

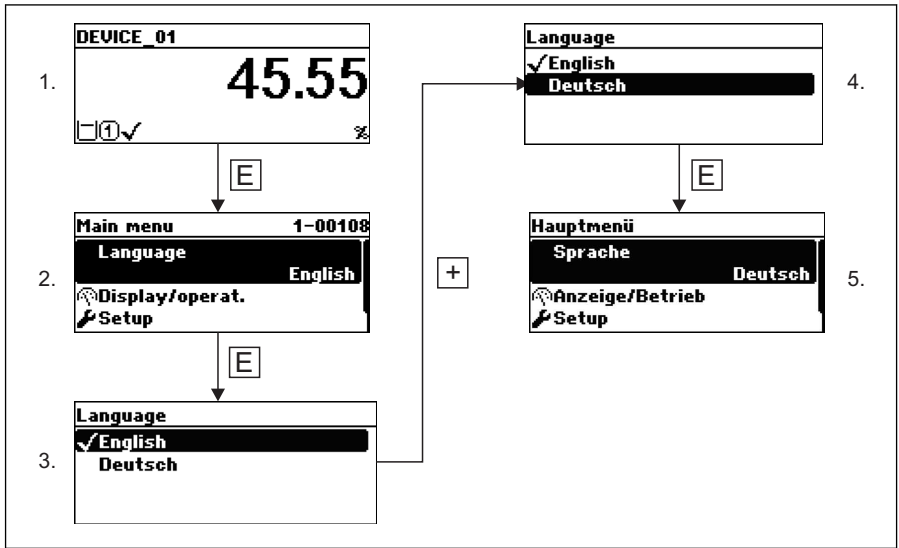

A0013637

9.6 Configuration of a level measurement

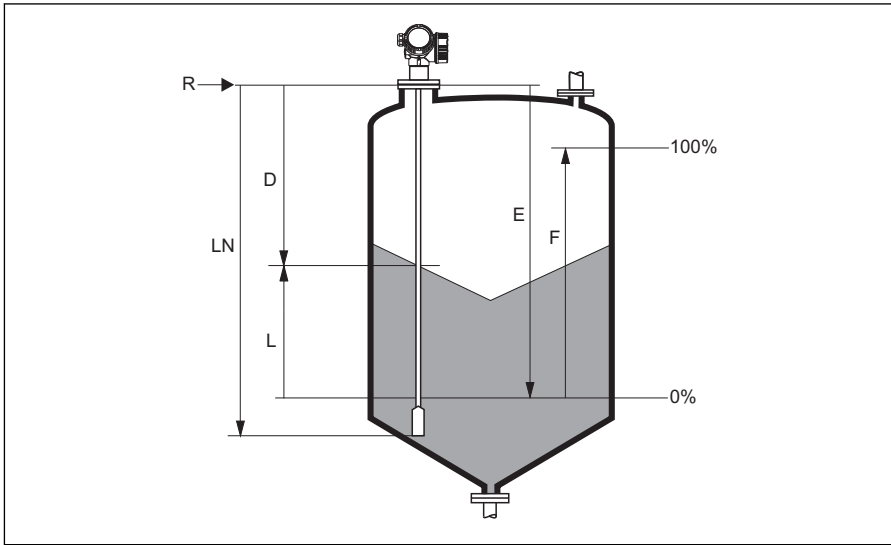

A0012838

15 Configuration parameters for level measurements in solids

LN = Length of probe

D = Distance

L = Level

R = Reference point of the measurement

E = Empty calibration (= Zero point)

F = Full calibration (= span)

Step	Parameter	Action
1	Setup → Distance unit	Select distance unit.
2	Setup → Bin property	Select bin property.
3	Setup → Empty calibration	Enter the distance E between the reference point R and the minimum level (0%).
4	Setup → Full calibration	Enter distance F between the minimum (0%) and maximum (100%) level.
5	Setup → Level	Displays the measured level L .
6	Setup → Distance	Displays the distance D between the reference point R and the level L .
7	Setup → Signal quality	Displays the signal quality of the level echo.
8	Setup → Mapping → Confirm distance	Compare the displayed distance to the real distance in order to start the recording of the mapping curve.

9.7 User-specific applications (operation)



For details of setting the parameters of user-specific applications, see separate documentation:

- Operator and Maintenance → BA01009F/00/EN (Operating Instructions)
- Experte → GP01001F/00/EN (Description of Device Parameters)

www.endress.com/worldwide

Endress+Hauser 

People for Process Automation

KA01073F/00/EN/13.12
71206500
CCS/COSIMA

