



Level



Pressure



Flow



Temperature



Liquid  
Analysis



Registration



Systems  
Components



Services



Solutions

Operating Instructions

# Nivotester FTC325 PFM

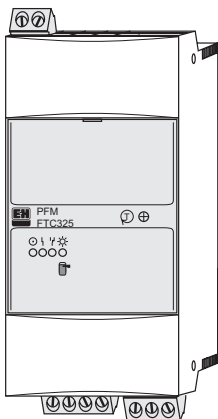

**de** - Füllstandgrenschalter mit PFM-Eingang

**en** - Level Limit Switch with PFM input

**fr** - Détecteur de niveau avec entrée PFM

**es** - Detector de nivel con entrada PFM

**it** - Interruttore di livello con ingresso PFM

**nl** - Niveauschakelaar met PFM ingang

KA221F/00/A6/06.10  
71118489

**Endress+Hauser**

People for Process Automation

## de - Inhalt

Sicherheitshinweise	4
Geräte-Identifikation	6
Messeinrichtung	8
Einbau	9
Anschluss	12
Frontplatte öffnen	15
Bedienelemente	16
Schaltpunktverschiebung zur Ansatzkompensation	20
Abgleichtaste	26
Test- und Korrekturtaste	28
Fehlersuche	30
Ergänzende Dokumentation	36

## en - Contents

Notes on Safety	4
Device Identification	6
Measuring system	8
Installation	9
Connection	12
Opening the front panel	15
Control elements	16
Switch point offset for build-up compensation	21
Calibration key	26
Test and correction key	28
Trouble-shooting	31
Supplementary Documentation	36

## fr - Sommaire

Conseils de sécurité	4
Désignation de l'appareil	6
Ensemble de mesure	8
Montage	9
Raccordement	12
Ouvrir la plaque frontale	15
Eléments de réglage	16
Déplacement du point de commutation pour compensation de colmatage	22
Touche d'étalonnage	26
Touche de test et de correction	28
Recherche de défauts	32
Documentation complémentaire	36



### **Achtung!**

= verboten;  
führt zu fehlerhaftem Betrieb  
oder Zerstörung.



### **Caution!**

= forbidden;  
leads to incorrect operation  
or destruction.



### **Attention!**

= interdit; peut provoquer  
des dysfonctionnements  
ou la destruction.

## es - Índice

Notas sobre seguridad	5
Identificación del equipo	6
Sistema de medida	8
Montaje	9
Conexiones	12
Abrir el panel frontal	15
Elementos de control	16
Desplazamiento del punto de conmutación para compensación de adherencias	23
Botón de calibración	26
Botón de prueba y corrección	28
Identificación de fallos	33
Documentación adicional	36

## it - Indice

Note sulla sicurezza	5
Identificazione dello strumento	6
Sistema di misura	8
Montaggio	9
Collegamenti	12
Aprendo il pannello frontale	15
Elementi di controllo	16
Posizione del commutatore per la compensazione dei depositi	24
Tasti di calibrazione	26
Tasti di correzione e test	28
Individuazione e eliminazione delle anomalie	34
Documentazione supplementare	36

## nl - Inhoud

Veiligheidsinstructies	5
Instrument-identificatie	6
Meetopstelling	8
Inbouw	9
Aansluiting	12
Frontplaat openen	15
Bedieningselementen	16
Schakelpuntverschuiving t. b. v. aangroei compensatie	25
Afregeltoets	26
Test- en correctietoets	28
Fout zoeken	35
Aanvullende documentatie	36



### Atención!

= Prohibido; peligro de mal funcionamiento o de destrucción.



### Attenzione!

= Vietato; pericolo di malfunzionamento o di distruzione.



### Opgelet!

= verboden; leidt tot foutieve werking of storing.

## de - Sicherheitshinweise

Der Nivotester FTC325 PFM darf nur als Messumformer-Speisegerät für Grenzschalter von Endress+Hauser mit Zweidraht-PFM-Signal verwendet werden. Bei unsachgemäßem Einsatz können Gefahren von ihm ausgehen.

Das Gerät **darf nur von qualifiziertem und autorisiertem Fachpersonal** unter strenger Beachtung dieser Betriebsanleitung, der einschlägigen Normen, der gesetzlichen Vorschriften und der Zertifikate (je nach Anwendung) eingebaut, angeschlossen, in Betrieb genommen und gewartet werden.

## en - Notes on Safety

The Nivotester FTC325 PFM may only be used as a measuring transmitter power supply for Endress+Hauser limit switches with two-wire PFM signals. If used incorrectly it is possible that application-related dangers may arise.

The level limit device may be installed, connected, commissioned, operated and maintained **by qualified and authorised personnel only**, under strict observance of these operating instructions, any relevant standards, legal requirements, and, where appropriate, the certificate.

## fr - Conseils de sécurité

Le Nivotester FTC325 PFM doit exclusivement être utilisé comme alimentation de transmetteur pour détecteurs de niveau Endress+Hauser avec signal PFM 2 fils.

Il peut être source de danger en cas d'utilisation non conforme aux prescriptions.

L'appareil ne doit être installé, raccordé, mis en service et maintenu **que par un personnel qualifié et autorisé**, qui tiendra compte des indications contenues dans la présente mise en service, des normes en vigueur et des certificats disponibles (selon l'application).

## es - Notas sobre seguridad

El Nivotester FTC325 PFM debe utilizarse únicamente como fuente de alimentación de detectores de nivel Endress+Hauser con señales PFM de dos hilos.

Su empleo inapropiado puede resultar peligroso.

El equipo deberá ser montado, conectado, instalado y mantenido única y **exclusivamente por personal cualificado y autorizado**, bajo rigurosa observación de las presentes instrucciones de servicio, de las normativas y legislaciones vigentes, así como de los certificados (dependiendo de la aplicación).

## it - Note sulla sicurezza

Il Nivotester FTC325 PFM può essere usato solo per alimentare sensori Endress+Hauser in tecnologia PFM.

Un'installazione non corretta può determinare pericolo.

Lo strumento FTC325 PFM deve essere montato, connesso, messo in funzione ed operato **solamente da personale qualificato ed autorizzato**, sotto la stretta osservazione delle presenti norme di installazione e manutenzione e delle ulteriori norme, regolamenti, disposizioni legali e, dove richiesto, dei certificati appropriati.

## nl - Veiligheidsinstructies

De Nivotester FTC325 PFM mag alleen als meetversterker/voeding voor niveauschakelaars met 2-draads PFM signalen, van Endress+Hauser worden gebruikt. Indien niet correct gebruikt kunnen gevaarlijke situaties ontstaan.

Het instrument alleen door **gekwalificeerd en geautoriseerd personeel** laten inbouwen, aansluiten, in bedrijf nemen en onderhouden. Neem de instructies in deze Inbedrijfstellingsvoorschriften de desbetreffende normen, de wettelijke voorschriften en eventuele certificaten in acht.

de - Geräte-Identifikation  
 en - Device Identification  
 fr - Désignation de l'appareil  
 es - Identificación del equipo  
 it - Identificazione dello strumento  
 nl - Instrument-identificatie

6

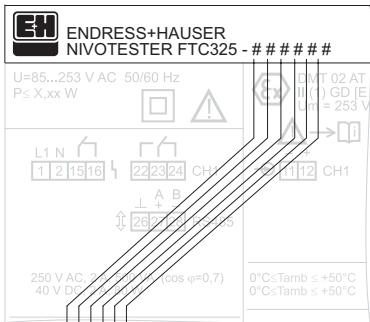

- A \*1
- B \*1, WHG
- C ATEX II (1) GD, [EEx ia] IIC, WHG
- D FM IS, Cl. I, II, III, Div. 1, Gp. A-G
- E CSA IS, Cl. I, II, III, Div. 1, Gp. A-G
- F CSA General Purpose
- S TIIS Ex ia IIC
- Y \*2

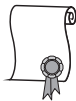

1 —

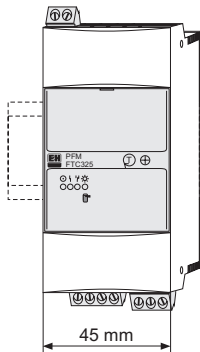

EN 60715 TH 35-7.5  
 EN 60715 TH 35-15

9 \*2

- A  $U_{\sim}$  85 V...253 V (AC), 50/60 Hz  
 B  $U_{\sim}$  20 V... 30 V (AC),  $U_{-}$  20 V... 60 V (DC)  
 Y \*<sup>2</sup>

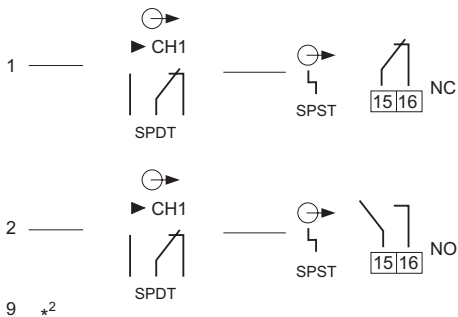

- 1 \*<sup>1</sup>  
 9 \*<sup>2</sup>

1 Messstelle (TAG) / Tagging (TAG) / repérage (TAG) /  
 etiqueta (TAG) / targhette (TAG) / meetplaats (TAG)

\*<sup>1</sup> ohne / without / sans / sin / senza / zonder

\*<sup>2</sup> andere / others / autres / otros / altri / andere

de - Messeinrichtung  
en - Measuring system  
fr - Ensemble de mesure  
es - Sistema de medida  
it - Sistema di misura  
nl - Meetopstelling

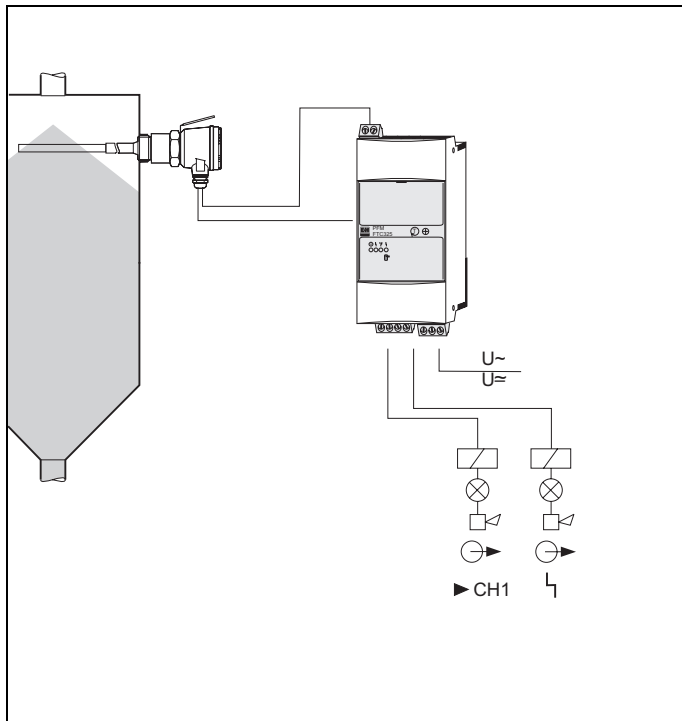



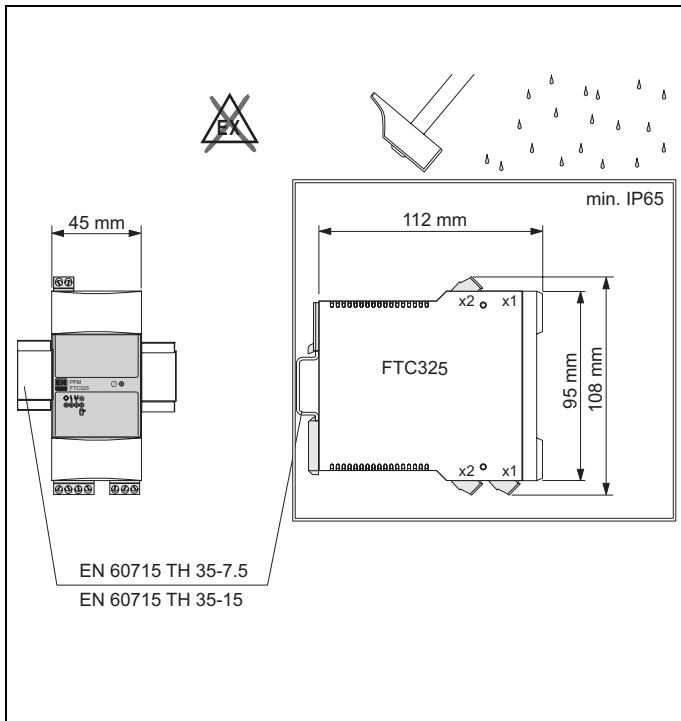

**de - Einbau**

Vor Beschädigung und  
Witterung geschützt

**en - Installation**

Protected against damage and  
weather

**fr - Montage**

Protéger contre les chocs et  
les intempéries

**es - Montaje**

Protegido contra daños e  
intemperie

**it - Montaggio**

Proteggere contro urti e  
intemperie

**nl - Inbouw**

Tegen beschadigingen en  
weersinvloeden beschermen

- de** - Mindestabstände
- en** - Minimum separation
- fr** - Intervalles min. entre deux appareils
- es** - Distancia mínima
- it** - Distanze minime
- nl** - Minimale afstand

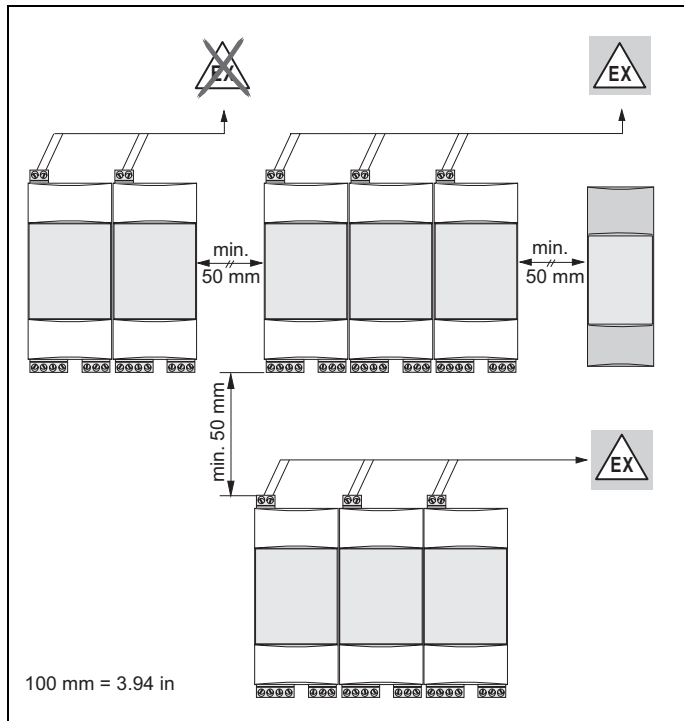

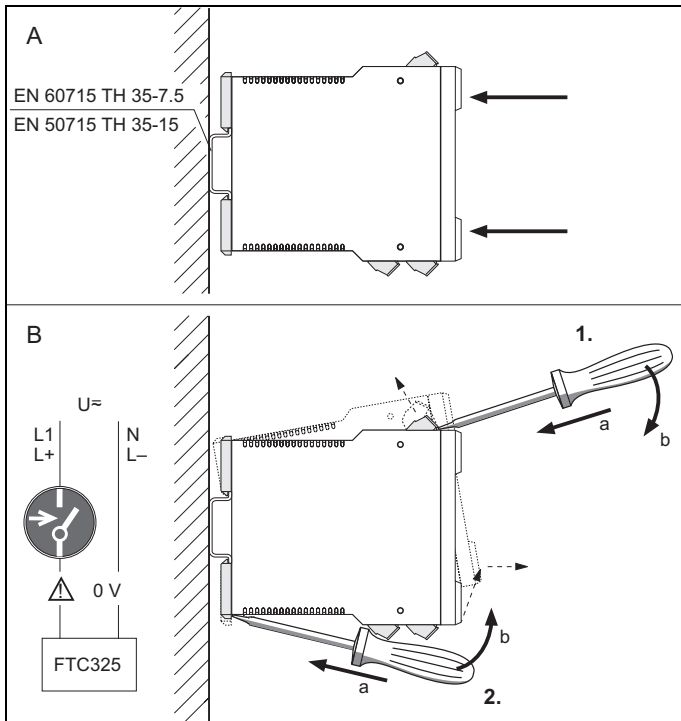

- de** - A: Montage auf Hutschiene  
B: Demontage  
1. Klemmenblöcke entfernen  
2. Gerät abnehmen

- en** - A: Rail mounting  
B: Dismantling  
1. Remove the terminal blocks  
2. Remove the unit

- fr** - A: Montage sur rail profilé  
B: Démontage  
1. Déconnecter les borniers  
2. Oter l'appareil

- es** - A: Montaje en raíl  
B: Desmontaje  
1. Quitar los bornes de conexión  
2. Quitar el instrumento

- it** - A: Montaggio su rotaia  
B: Smontaggio  
1. Togliere il blocchetto morsetti  
2. Togliere lo strumento

- nl** - A: Railmontage  
B: Uitebouw  
1. Klemmenblok verwijderen  
2. Instrument verwijderen

**de - Anschluss**

Anordnung der Klemmen  
Hilfsenergie

**en - Connection**

Terminal arrangement  
Power supply

**fr - Raccordement**

Agencement des bornes  
Alimentation

**es - Conexiones**

Asignación de terminales  
Alimentación

**it - Collegamenti**

Ordinamento dei terminali  
Alimentazione

**nl - Aansluiting**

Klemmen positie  
Voedingspanning

Typenschild beachten!

Note name plate!

Tenir compte  
de la plaque signalétique!

Ver identificación!

Targhetta note!

Typeplaatje bekijken!

N L1 U~ 85...253 V (AC)  
50/60 Hz

L- L+ U= 20... 60 V (DC)

N L1 U~ 20... 30 V (AC)  
50/60 Hz

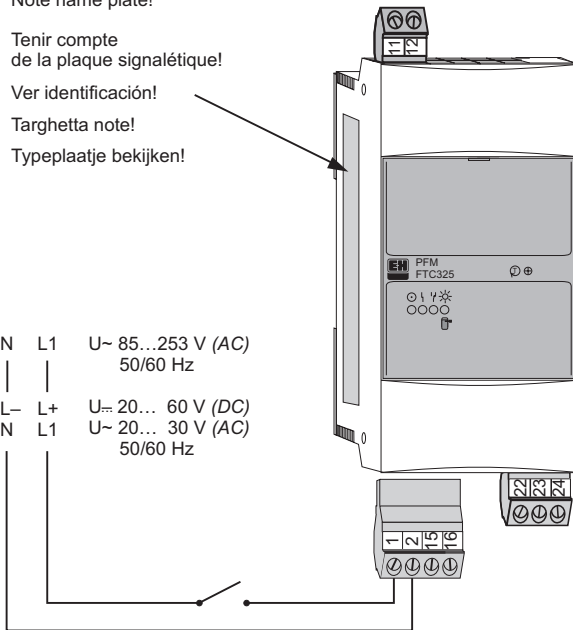

anschließbare Sonden mit: / connectable probes with: /  
 sondes raccordables avec: / puntas de prueba  
 conectables con: / sonda raccordabili con: /  
 aansluitbare sondes met:

Liquicap M (FTI51, FTI52)  
 Solicap M (FTI55, FTI56)  
 Solicap S (FTI77) } FEI57S

Solicap (FTC51, FTC52, FTC53)\*  
 Multicap T\*  
 Multicap Classic\*  
 T12656\*\*\*, T12892\*\*\*  
 11304\*\*, 11500\*\* } EC17Z

Multicap EA\* } EC17Z /  
 EC16Z

Nivotester FTC325 PFM

Hinweis / Note / Remarque / Note / Nota / Opmerking



- de** - Anschluss der Messaufnehmer
- en** - Sensor connection
- fr** - Raccordement des capteurs
- es** - Conexión de sensor
- it** - Connessione sensore
- nl** - Aansluiting van de sensor

- \* Phase-out 2007
- \*\* Phase-out 2008
- \*\*\* Phase-out 2009

**de** - Anschluss der Ausgänge  
**en** - Output connection  
**fr** - Raccordement des sorties  
**es** - Conexión de la salida  
**it** - Connessione d'uscita  
**nl** - Aansluiting van de uitgangen

U~ max. 253 V (AC)  
 I~ max. 2 A (AC)  
 P~ max. 500 VA /  $\cos \varphi \geq 0.7$   
 U:: max. 40 V (DC)  
 I:: max. 2 A (DC)  
 P:: max. 80 W

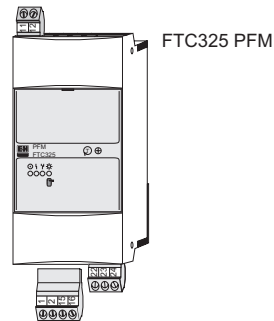

Grenzsinal / Limit signal /  
 Signal de seuil / Señal de límite /  
 Soglia d'intervento / Niveausignaal



CH1



Störung / Fault / Défaut /  
 Fallo / Guasto / Storing

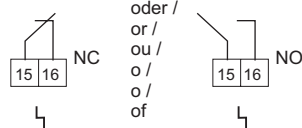

Frontplatte öffnen /  
Opening the front panel /  
Ouvrir la plaque frontale /  
Abrir el panel frontal /  
Apriendo il pannello frontale /  
Frontplaat openen

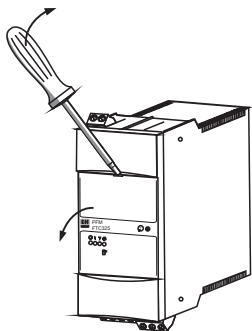

Symbolik / Symbols / Symboles / Símbolos / Simboli / Symbolen

$\Delta S$  Zweipunktsteuerung / Two-point control / Régulation entre deux points /  
Control entre dos puntos / Per il controllo su due punti / 2-puntsregeling

 leuchtet / on / allumée / iluminado / on / aan

 blinkt / flashes / clignote / parpadea / lampeggia / knippert

 aus / off / éteinte / apagado / off / uit

 Ausgangssignal / Output signal / Signal de sortie /  
Señal de salida / Segnale uscita / uitgangssignaal

 Störung / Fault / Défaut / Fallo / Guasto / storing

 siehe Seite .. / see page .. / voir page .. / ver pág. .. / vds. pag. .. / zie pag ..

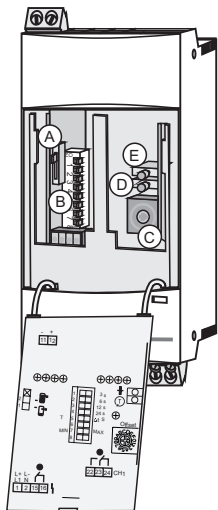

- (A)** Calibration mode  
 covered probe  
 uncovered probe
- (B)**
- |   |             |   |            |
|---|-------------|---|------------|
| 1 | 0/ 3 s      | } max. 45 s = $\Delta t$ (switching delay time) | } → 18     |
| 2 | 0/ 6 s      |   |            |
| 3 | 0/12 s      |   |            |
| 4 | 0/24 s      |   |            |
| 5 | $\Delta t$  | Delay when uncovering or covering the probe     | } → 19     |
| 6 | no function |   |            |
| 7 | MIN/MAX     | Fail-safe mode                                  | } → 20 . . |
| 8 | no function |   |            |
- (C)** Switch point shift for build-up compensation  
 (Before calibration the switch position must be on left limit stop)
- (D)** Test and correction key (green)
- (E)** Calibration key (red)



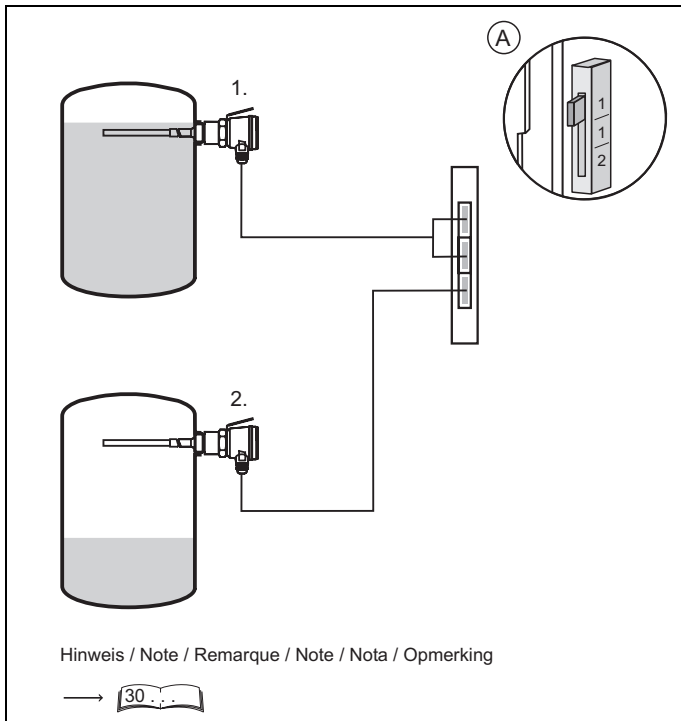

- de** - Sondenzustand beim Abgleich:
1. Bedeckt (oben/mitte)
  2. Frei (unten)
- en** - Probe condition at calibration:
1. Covered (top/middle)
  2. Uncovered (bottom)
- fr** - Etat de la sonde lors de l'étalonnage :
1. recouverte (en haut/milieu)
  2. libre (en bas)
- es** - Estado de la sonda durante la calibración:
1. cubierta (arriba/medio)
  2. descubierta (abajo)
- it** - Condizioni di calibrazione:
1. sonda coperta (in alto/centro)
  2. sonda scoperta (in basso)
- nl** - Sensorstatus bij afregeling:
1. Bedekt (boven/midden)
  2. Vrij (onder)

**de** - DIL-Schalter:  
Schaltverzögerung  
beim Bedecken (ON)  
beim Freiwerden (OFF)

**en** - DIL switch:  
Switching delay  
when covering (ON)  
when uncovering (OFF)

**fr** - Commutateur DIL :  
Temporisation  
au recouvrement (ON)  
au découvrement (OFF)









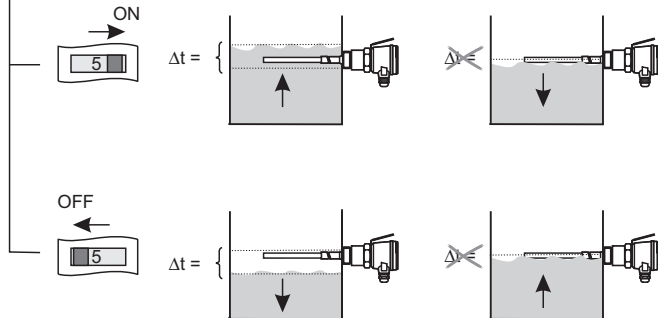
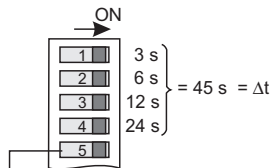
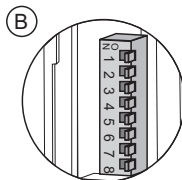

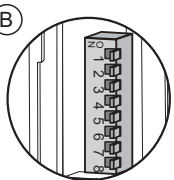
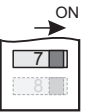
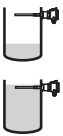
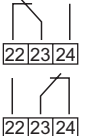
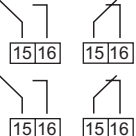
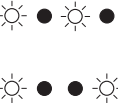
**es** - Interruptor DIL:  
Temporización  
si está cubierta (ON)  
si está descubierta (OFF)

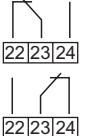
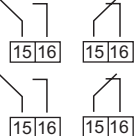
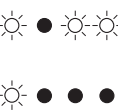
**it** - Commutatori DIL:  
per la temporizzazione  
quando coperto (ON)  
quando scoperto (OFF)

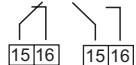
**nl** - DIP-schakelaar:  
Tijdvertraging  
bij bedekken (ON)  
bij vrijkomen (OFF)

Zuerst den Abgleich durchführen!  
Perform calibration first!  
Procéder d'abord à l'étalonnage!  
Efectuar primero la compensación!  
Innanzi tutto portare a livello!  
Eerst de inregeling uitvoeren!

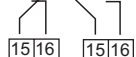

Sicherheits- schaltung Fail-safe circuit Circuit de sécurité Circuito de seguridad Circuito di sicurezza Fail-safe keuze	Füllstand Level Niveau Nivel Livello Niveau	Füllstandalarm Level alarm Alarme de niveau Alarma de nivel Allarme di livello Niveau-alarm	 NC NO		 gn rd ye ye
MAX ON 					
MIN OFF 					
Störung / Fault / Défaut / Fallo / Guasto / Storing 					
					

**de** - DIL-Schalter:  
Min/Max-Sicherheit  
Störmelderelais

**en** - DIL switch:  
Min/Max safety  
Alarm relay

**fr** - Commutateur DIL :  
Sécurité Min/Max  
Relais d'alarme

**es** - Interruptor DIL:  
Seguridad mín./máx.  
Relé de alarma

**it** - Commutatore DIL:  
sicurezza di min/max  
relè d'allarme

**nl** - DIP-schakelaar:  
Min/max-veiligheid  
Alarmrelais

## de - Schaltpunktverschiebung zur Ansatzkompensation

Schalterstellung und  
Schaltpunktverschiebung bei  
Anfangskapazität (CA) = 30 pF

0,8 pF = max. Empfindlichkeit  
48,0 pF = min. Empfindlichkeit

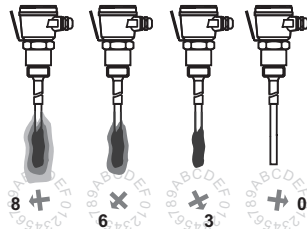

Einstellungen

0 = 0,8 pF ... 9 = 48,0 pF

Füllgut- beispiele	$\epsilon_r$	Leitfähig- keit	Ansatz- bildung	Sondenbauart				Standard Schalterstellung	
				Isolation		Masserohr		Standard- betrieb	Betrieb als Überfüll- sicherung
				Voll-	Teil-	mit	ohne		
Lösungsmittel, Treibstoffe	< 3	gering	gering	✓	✓	✓	-	2 - 3	3
trockene Schüttgüter	< 3	gering	gering	-	✓	-	✓	2 - 3	-
feuchte Schüttgüter	> 3	mittel	mittel	✓	✓	-	✓	4 - 5	-
wasserhaltige Flüssigkeiten und Alkohole	> 3	hoch	gering	✓	✓	-	✓	4 - 5	4
			stark	-	✓	-	✓	6 - 7	5
Schlamm	> 3	hoch	sehr stark	-	✓	-	✓	8 - 9	-

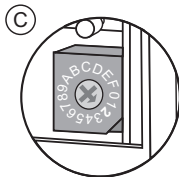
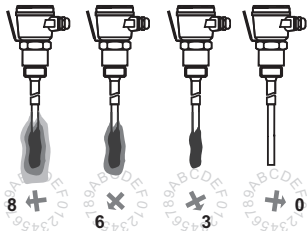

Setting-up

0 = 0.8 pF ... 9 = 48.0 pF

## en - Switch point offset for build-up compensation

Switch position and switch point offset at initial capacity  
(CA) = 30 pF

0.8 pF = max. sensitivity

48.0 pF = min. sensitivity

Example: Material	εr	Conductivity	Build-up	Type of probe mounting				Standard switch position	
				Insulation		Ground tube		Standard operation	Operation as overspill protection
				Full	Part	with	without		
Solvents, fuels	< 3	low	low	✓	✓	✓	-	2 - 3	3
Dry bulk solids	< 3	low	low	-	✓	-	✓	2 - 3	-
Moist bulk solids	> 3	average	average	✓	✓	-	✓	4 - 5	-
Aqueous liquids and alcohols	> 3	strong	low	✓	✓	-	✓	4 - 5	4
			strong	-	✓	-	✓	6 - 7	5
Sludge	> 3	strong	very strong	-	✓	-	✓	8 - 9	-

## fr - Déplacement du point de commutation pour compensation de colmatage

Position du commutateur et déplacement du point de commutation à la capacité initiale (CA) = 30 pF

0,8 pF = sensibilité max.

48,0 pF = sensibilité min.

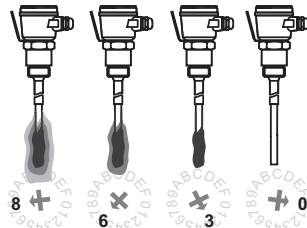

Réglage

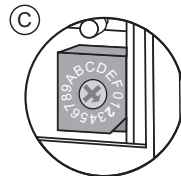

0 = 0,8 pF ... 9 = 48,0 pF

Exemples de produit	Er	Conductivité	Formation de dépôts	Construction de la sonde				Position standard du commutateur	
				Isolation totale	Isolation partielle	Tube de masse avec	Tube de masse sans	Fonctionnement standard	Fonctionnement comme sécurité anti-déboîtement
Solvants, carburants	< 3	faible	faible	✓	✓	✓	-	2 - 3	3
Solides en vrac secs	< 3	faible	faible	-	✓	-	✓	2 - 3	-
Solides en vrac humides	> 3	moyenne	moyenne	✓	✓	-	✓	4 - 5	-
Liquides aqueux et alcools	> 3	élevée	faible	✓	✓	-	✓	4 - 5	4
			élevée	-	✓	-	✓	6 - 7	5
Boue	> 3	élevée	très élevée	-	✓	-	✓	8 - 9	-

C

0 = 0.8 pF ... 9 = 48.0 pF

Material de ejemplo	$\epsilon_r$	Conductividad	Adherencias	Tipo de montaje de sonda				Posición estándar interruptor	
				Aislamiento		Tubo de tierra		Funcionamiento estándar	Funcionamiento con protección contra reboso
				total	parcial	con	sin		
Disolventes, combustibles	< 3	baja	baja	✓	✓	✓	-	2 - 3	3
Áridos	< 3	baja	baja	-	✓	-	✓	2 - 3	-
Sólidos en grano húmedos	> 3	media	media	✓	✓	-	✓	4 - 5	-
Líquidos acuosos y alcoholes	> 3	alta	baja	✓	✓	-	✓	4 - 5	4
			alta	-	✓	-	✓	6 - 7	5
Fangos	> 3	alta	muy alta	-	✓	-	✓	8 - 9	-

## es - Desplazamiento del punto de conmutación para compensación de adherencias

Posición del conmutador y desplazamiento del punto de conmutación en la capacidad inicial (CA) = 30 pF

0.8 pF = máx. sensibilidad

48.0 pF = mín. sensibilidad

## it - Posizione del commutatore per la compensazione dei depositi

Posizione del commutatore e offset alla capacità iniziale (CA) = 30 pF

0.8 pF = sensibilità max.

48.0 pF = sensibilità min.

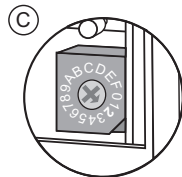
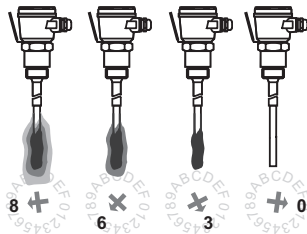

Messa in servizio

0 = 0.8 pF ... 9 = 48.0 pF

Esempi di materiali	$\epsilon_r$	Conducibilità	Depositi	Tipo di sonda				Posizione commutatore standard	
				Isolamento		Tubo di massa		Funzionamento standard	Antitrascinamento
				totale	parziale	con	senza		
Solventi, Carburanti	< 3	bassa	bassi	✓	✓	✓	-	2 - 3	3
Solidi secchi	< 3	bassa	bassi	-	✓	-	✓	2 - 3	-
Solidi umidi	> 3	media	medi	✓	✓	-	✓	4 - 5	-
Liquidi acquosi e alcoholi	> 3	forte	bassi	✓	✓	-	✓	4 - 5	4
			forti	-	✓	-	✓	6 - 7	5
Fanghi	> 3	forte	molto forti	-	✓	-	✓	8 - 9	-



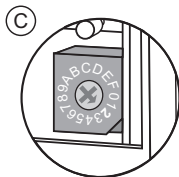
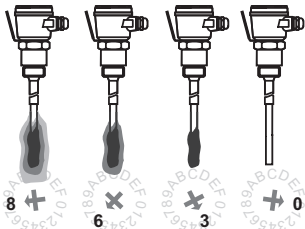

Instellingen

0 = 0,8 pF ... 9 = 48,0 pF

Vulgoed-voorbeelden	Er	Geleid-baarheid	Aangroei	Sensortype				Standaard Schakelstand	
				vol-	deels-	met	zonder	Standaard bedrijf	Functie als overvul beveiliging
Oplosmiddelen, brandstoffen	< 3	gering	gering	✓	✓	✓	-	2 - 3	3
Droog stortgoed	< 3	gering	gering	-	✓	-	✓	2 - 3	-
Vochtig stortgoed	> 3	middel	middel	✓	✓	-	✓	4 - 5	-
Waterhoudende vloeistoffen en alcoholen	> 3	hoog	gering	✓	✓	-	✓	4 - 5	4
			sterk	-	✓	-	✓	6 - 7	5
Slib	> 3	hoog	zeer sterk	-	✓	-	✓	8 - 9	-

nl - Schakelpuntverschuiving  
 t. b. v. aangroei compensatie  
 Schakelaarpositie in  
 schakelpuntverschuiving bij  
 aanvangscapaciteit (CA) = 30 pF

0,8 pF = max. gevoeligheid

48,0 pF = min. gevoeligheid

**de - Abgleichtaste**

bei MAX-Anwendung

**en - Calibration key**

at MAX application

**fr - Touche d'étalonnage**

pour sécurité MAX

**es - Botón de calibración**









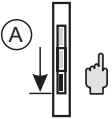
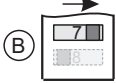

a nivel MÁX

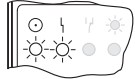
**it - Tasti di calibrazione**

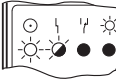
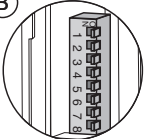
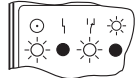
applicazione di MAX

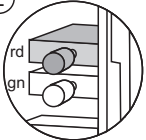
**nl - Afregeltoets**

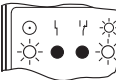
bij MAX toepassing

1. 	2. 	3. MAX ON 	(A) 
4. 	5. 	6. 	(B) 
7. 	8. 	9. 	(E) 
optional / optional / en option / opcional / orizzontale / optie			→ Kontrolle / check / contrôle / control / controllo / controle
1. 	2. 	3. 	4. 

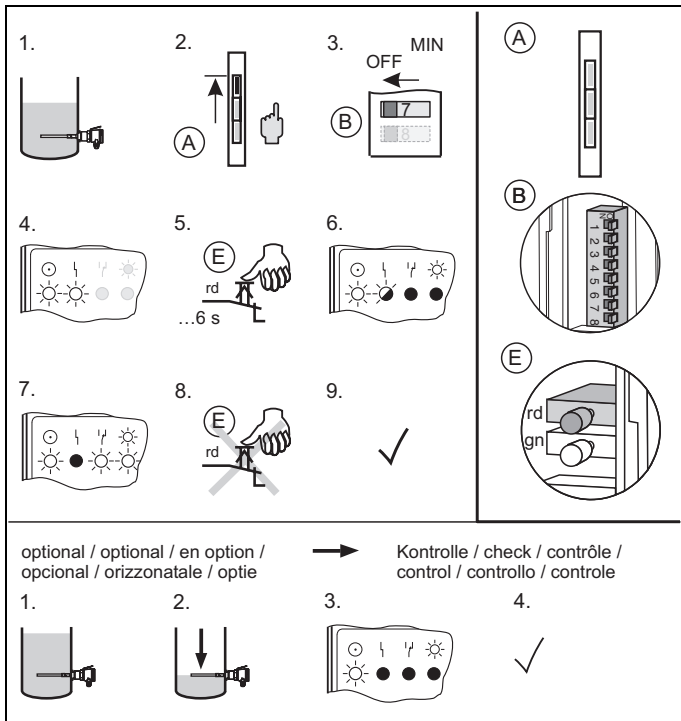

**de - Abgleichtaste**

bei MIN-Anwendung

**en - Calibration key**

at MIN application

**fr - Touche d'étalonnage**

pour sécurité MIN

**es - Botón de calibración**

a nivel MIN

**it - Tasti di calibrazione**

applicazione di MIN

**nl - Afregeltoets**

bij MIN toepassing

**de - Test- und Korrekturtaste**

Funktionstest Ausgänge

**en - Test and correction key**

Function test of outputs

**fr - Touche de test et de correction**

Test de fonctionnement sorties

**es - Botón de prueba y corrección**

Prueba de funcionamiento de las salidas

**it - Tasti di correzione e test**

verifica di funzionamento dell'uscita

**nl - Test-en correctietoets**

Functietest uitgangen

Beispiel MAX / example MAX / exemple MAX /  
ejemplo MAX / esempio MAX / voorbeeld MAX

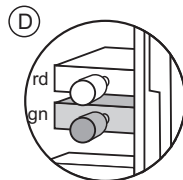

1.

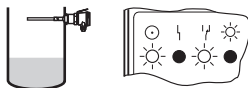

2.

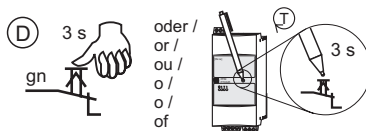

3. Störung / Fault / Défaut /  
Fallo / Guasto / Storing

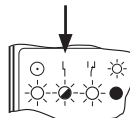

4.

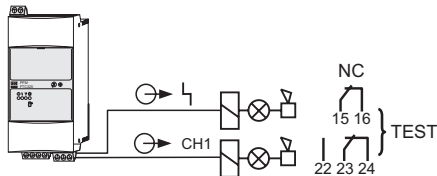

1.



2.

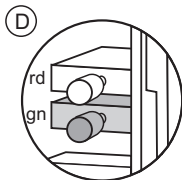
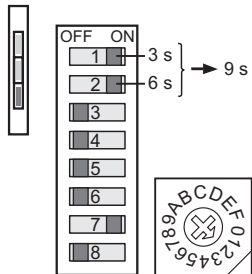

3. Störung / Fault / Défait /  
Fallo / Guasto / Storing

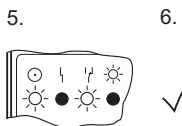
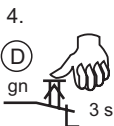
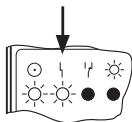

**de - Test- und Korrekturtaste**  
Änderung z.B. Schaltverzögerung

**en - Test and correction key**  
Change, e. g. switching delay

**fr - Touche de test et de correction**  
Modification par ex. temporisation

**es - Botón de prueba y corrección**  
Modificación, por ej. temporización

**it - Tasti di correzione e test**  
ad esempio del tempo di ritardo

**nl - Test- en correctietoets**  
Wijziging bijv. schakelvertraging

## de - Fehlersuche

Hinweis!

Ein Neuabgleich ist erforderlich, wenn:

- beim EC17Z die Brückenstellung geändert wurde
- der Elektronikeinsatz der Sonde ausgetauscht wurde.

Fehlfunktion	Ursache	Maßnahme
Schaltet nicht	Versorgungsspannung fehlt (Grüne Leuchtdiode aus)	Versorgung prüfen
	Nivotester defekt	Nivotester austauschen
	Kontakte verschweißt (nach einem Kurzschluss)	FTC325 austauschen; Sicherung in den Kontaktstromkreis
	Messaufnehmer defekt	Messaufnehmer austauschen
Schaltet falsch	Im FTC325 Umschalter für Grenzsinal falsch eingestellt	Umschalter hinter der Frontplatte richtig einstellen
Dauernde Störungsmeldung	Gerätekonfiguration unbeabsichtigt geändert	Ursprünglichen Zustand wieder herstellen
	Gerätekonfiguration geändert	Korrekturtaste für 3 s drücken
	Unterbrechung oder Kurzschluss der Leitung zum Messaufnehmer	Leitung überprüfen
	Messaufnehmer-Elektronik defekt	Messaufnehmer-Elektronik austauschen
Störungsmeldung blinkt	Sondenstromkreis (Sonde, Elektronikeinsatz oder Zweidrahtleitung)	Verbindungsleitungen kontrollieren
		Anschluss des Elektronikeinsatzes zu der Sonde kontrollieren
		Sonde auf Masseschluss prüfen (R <sub>soll</sub> > 200 kOhm)
		Elektronikeinsatz austauschen und neuen Abgleich durchführen
		Nach dem Erlöschen der Leuchtdiode neuen Abgleich durchführen und Funktion überprüfen
Abgleich bei bedeckter Sonde nicht möglich	Messbereich des Elektronikeinsatzes im bedeckten Zustand überschritten	Abgleich bei unbedeckter Sonde durchführen Sonde auf Masseschluss prüfen

Fault	Reason	Remedy
Does not switch	No power (green LED does not light up)	Check power
	Nivotester defect	Replace Nivotester
	Contacts welded together (after short-circuit)	Replace FTC325; connect a fuse into contactor circuit
	Measuring transmitter defective	Replace measuring transmitter
Switches incorrectly	Incorrect setting of change-over switch for limit signal in FTC325	Correctly set change-over switch behind front panel
Permanent alarm signal	Device configuration changed unintentionally	Restore original condition
	Device configuration changed	Press correction key for 3 s
	Interrupt or short-circuit line to measuring transmitter	Check line
	Measuring transmitter electronics defective	Replace measuring transmitter electronics
	Nivotester defective	Replace Nivotester
Fault indicator flashes	Probe circuit (probe, electronic insert or two-wire cable)	Check connecting wires
		Check connection from electronic insert to the probe
		Check probe for grounding ( $R_{nom} > 200 \text{ k}\Omega$ )
		Replace electronic insert and recalibrate
		After the LED goes out, recalibrate and check function
Calibration not possible when probe is covered	The measuring range of the electronic insert is exceeded in the covered condition	Calibrate with uncovered probe Check probe for grounding

## en - Trouble-shooting

Note!

A new calibration is necessary:

- if the bridge position of the EC17Z was changed
- if the electronic insert of the probe was exchanged.

## fr - Recherche de défauts

Remarque !

Un nouvel étalonnage est nécessaire lorsque :

- la position du pont a été modifiée dans le cas de l'EC17Z
- l'électronique de la sonde a été remplacée.

Défaut	Cause	Mesure
Ne commute pas	Absence tension d'alimentation (diode verte éteinte)	Vérifier l'alimentation
	Nivotester défectueux	Remplacer le Nivotester
	Contacts soudés (après un court-circuit)	Remplacer le FTC325; insérer un fusible dans le circuit du contact
	Capteur défectueux	Remplacer le capteur
Mauvaise commutation	Dans le FTC325, commutateur pour signal de seuil mal réglé	Régler correctement le commutateur derrière la plaque frontale
Mauvaise commutation, sporadique	Configuration appareil modifiée accidentellement	Recréer l'état d'origine
	Configuration appareil modifiée	Appuyer sur la touche de correction pendant 3 s
	Interruption ou court-circuit de la liaison au capteur	Vérifier la liaison
	Electronique du capteur défectueuse	Remplacer l'électronique du capteur
	Nivotester défectueux	Remplacer le Nivotester
Message alarme clignote	Circuit de la sonde (sonde, électronique ou liaison 2 fils)	Contrôler les câbles de liaison
		Contrôler le raccordement de l'électronique à la sonde
		Vérifier si court-circuit à la terre au niveau de la sonde (Rconsigne > 200 kOhm)
		Remplacer l'électronique et réétalonner
		Quand DEL éteinte, réétalonner et vérifier le fonctionnement
Etalonnage impossible si la sonde est recouverte	Gamme de mesure de l'électronique dépassée par excès avec sonde recouverte	Etalonner lorsque la sonde est découverte Vérifier si court-circuit à la terre au niveau de la sonde



Fallo	Causa	Solución
No conmuta	No hay alimentación (el LED verde no está iluminado)	Compruebe la alimentación
	Nivotester defectuoso	Sustituya el Nivotester
	Contactos soldados juntos (después del corto circuito)	Sustituya el FTC325; conecte un fusible en el circuito contactor
	Sensor defectuoso	Sustituya el sensor
Conmuta incorrectamente	Ajuste incorrecto de la señal de límite en FTC325	Posicione correctamente el interruptor en el frontal
Aviso de fallo constante	La configuración del equipo se ha cambiado intencionadamente	Restaurar condiciones originales
	La configuración del equipo ha cambiado	Presione el botón de corrección durante 3 s
	Interrupción o cortocircuito de la conexión con el sensor	Compruebe el cableado
	Electrónicas del transmisor defectuosas	Sustituya la electrónica del transmisor
	Nivotester defectuoso	Sustituya el Nivotester
El indicador de fallo parpadea	Circuito de la sonda (sonda, electrónica o cable bifilar)	Compruebe los cables de conexión
		Compruebe la conexión desde la electrónica hasta la sonda
		Verifique si la sonda está cortocircuitada a tierra ( $R_{nom} > 200 \text{ k}\Omega$ )
		Sustituya la electrónica y calibre de nuevo
		Al apagarse el LED, recalibrar y comprobar funcionamiento
La calibración es imposible si la sonda está cubierta	El rango de la electrónica ha sido sobrepasado en condiciones de sonda cubierta	Calibrar cuando la sonda esté descubierta Verifique si la sonda está cortocircuitada a tierra

## es - Identificación de fallos

Note!

Es necesaria una nueva calibración:

- Si cambia la posición del puente de la EC17Z
- Si la electrónica de la sonda ha sido cambiada.

## it - Individuazione e eliminazione delle anomalie

Nota!

E' necessaria una nuova calibrazione:

- se viene cambiata la posizione del cavallotto sul preamplificatore EC17Z
- se viene cambiato il preamplificatore.

Guasto	Motivo	Rimedio
Non commuta	Mancanza alimentazione (LED verde spento)	Controllare l'alimentazione
	Nivotester guasto	Sostituire il Nivotester
	Contatti saldati insieme (dopo il corto circuito)	Sostituire FTC325; mettere il fusibile nel circuito di contatto
	Trasmettitore di misura difettoso	Sostituire trasmettitore di misura
Commuta non correttamente	Settaggio FTC325 non corretto	Correggere il punto di misura
Segnali di allarme permanente	La configurazione del dispositivo è stata erroneamente cambiata	Riposizionare le condizioni originali
	La configurazione del dispositivo è cambiata	Premere il tasto corrente 3 s
	Interruzione del collegamento al trasmettitore	Verifica la linea
	Trasmettitore di misura elettronica difettoso	Sostituire trasmettitore di misura elettronica
	Nivotester guasto	Sostituire il Nivotester
L'indicatore di guasto lampeggia	Circuito sonda non funzionante (Sonda, inserto elettronico o cavi bifilare)	Verificare i cablaggi
		Verifica la connessione tra sonda
		Verificare isolamento sonda (R <sub>soll</sub> > 200 kOhm)
		Sostituire l'inserto e ricalibrare
		Dopo lo spegnimento del LED ricalibrare e verificare la funzione
La calibrazione a sonda coperta non è possibile	Il valore di misura dell'inserto elettronico eccede le condizioni di taratura per sonda coperta	Calibrare la sonda scoperta verificare le messe a terra

Fout	Oorzaak	Maatregel
Schakelt niet	Voeding ontbreekt (groene LED = uit)	Voeding controleren
	Nivotester defect	Nivotester wisselen
	Contacten verkleefd (na kortsluiting)	FTC325 wisselen; zekering in schakelkring opnemen
	Sensor defect	Sensor wisselen
Schakelt foutief	In de FTC325 niveausignaal fout ingesteld	Omschakelaar achter de frontplaat goed instellen
Continu stooralarm	Instrument onbedoeld gewijzigd	Oorspronkelijke instelling herstellen
	Instrumentconfiguratie gewijzigd	Correctietoets 3 s indrukken
	Onderbreking of kortsluiting van sensor leiding	Leiding controleren
	Sensor elektronica defect	Sensor elektronica wisselen
	Nivotester defect	Nivotester wisselen
Storingsalarm knippert	Sensorleiding (sensor, elektronica unit of 2-draads leiding)	Verbindingen controleren
		Aansluiting van de sensor en elektronica unit controleren
		Sensor op kortsluiting controleren (Ri > 200 kOhm)
		Elektronica unit wisselen en opnieuw afregelen
		Na het uitgaan van de LED opnieuw afregelen en functie controleren
Afregeling niet mogelijk bij bedekte sensor	Het meetbereik van de elektronica-unit is overschreden in bedekte toestand	Afregeling bij onbedekte sensor uitvoeren Sensor controleren op massakortsluiting

## nl - Fout zoeken

Opmerking!

Een nieuwe inregeling is noodzakelijk indien:

- bij de EC17Z de positie van de doorverbindingsbrugjes gewijzigd wordt
- als de elektronica insert vervangen wordt.

**de - Ergänzende  
Dokumentation**

**en - Supplementary  
Documentation**

**fr - Documentation  
complémentaire**

**es - Documentación  
adicional**

**it - Documentazione  
supplementare**

**nl - Aanvullende  
documentatie**

Technische Information / Technical Information / Information technique /  
Información técnica / Informazioni tecniche / Technische Informatie

TI380F

Sicherheitshinweise / Notes on Safety / Conseils de sécurité /  
Notas sobre seguridad / Note sulla sicurezza / Veiligheidsinstructies

XA195F

**CE**  II (1) GD, EEx ia/ib IIC/IIB

[www.endress.com/worldwide](http://www.endress.com/worldwide)

