



Level



Pressure



Flow



Temperature



Analytics



Registration

Systems
Components

Services



Solutions

Technical Information

Condumax CLS21 and CLS21D

Conductivity sensors, analog or digital with Memosens technology

Cell constant $k = 1 \text{ cm}^{-1}$



Application

Measurements in media of medium and high conductivities:

- Medium separation in medium conductivities (milk/water)
- Medium separation in high conductivities (alkaline solution/water)
- Drinking water treatment
- Wastewater treatment

The cell constant of the sensor is $k = 1 \text{ cm}^{-1}$. The measuring range reaches from $10 \mu\text{S}/\text{cm}$ to $20 \text{ mS}/\text{cm}$.

Sensors with a temperature sensor are used together with conductivity transmitters equipped with automatic temperature compensation:

- Liquiline CM442 / CM444 / CM448 (CLS21D only)
- Liquiline CM42
- Liquiline CM14 (CLS21D only)
- Mycom CLM153
- Lquisys CLM223/253

For measurement of resistivity, $\text{M}\Omega \cdot \text{cm}$ measuring ranges are available in the menus of these transmitters.

Your benefits

- Various designs guarantee optimum adaptation to the process conditions and methods of installation
- Installation in pipes or flow chambers
- Compact design
- Available with plug-in head or fixed cable
- High chemical, thermal and mechanical stability
- IP 65 (with four-pole plug-in head) / IP 67 (with fixed cable) / IP 68 (with Memosens plug-in head)
- Quality certificate with statement of the individual cell constant

Further benefits offered by Memosens technology

- Maximum process safety through contactless inductive signal transmission
- Data safety through digital data transmission
- Easy handling thanks to storage of sensor-specific data in the sensor
- Predictive maintenance possible thanks to registration of sensor load data in the sensor

Function and system design

Measuring principle

Conductive measurement of conductivity

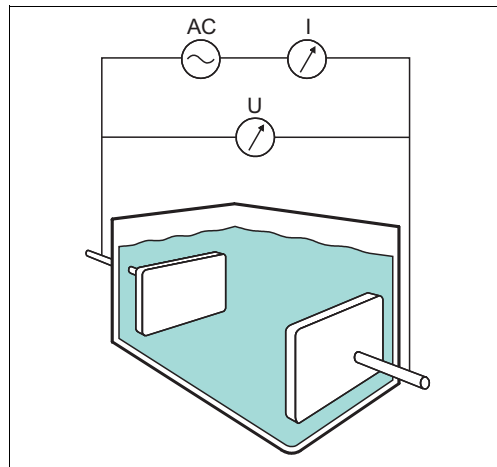

The conductivity of liquids is measured with the following measurement setup: Two electrodes are immersed in the medium. An AC voltage is applied to these electrodes which generates a current in the medium.

The electric resistance or its reciprocal value, the conductance G , is calculated according to Ohm's law. The specific conductivity κ is determined using the cell constant k that is dependent on the sensor geometry.

Conductive measurement of conductivity

•0003416

AC Power supply
I Current meter
U Voltage meter

General properties

■ Electrodes

The sensor has two coaxial electrodes made of graphite for a large measuring range. The graphite guarantees high chemical stability and low polarization effects.

■ Temperature compensation

A temperature sensor is integrated to measure the medium temperature.

■ Durability

- The sensor is pressure-proof up to 16 bar at 20 °C (232 psi at 68 °F).
- It can be applied with temperatures of up to 135 °C at 2.5 bar (275 °F at 36.3 psi).

Communication and data processing with CLS21D

Digital sensors are able to store the following system data in the sensor:

■ Manufacturing data

- Serial number
- Order code
- Date of manufacture

■ Calibration data

- Calibration date
- Cell constant
- Change in cell constant
- Number of calibrations
- Serial number of the transmitter used for the last calibration

■ Application data

- Temperature application range
- Conductivity application range
- Date of first commissioning
- Maximum temperature value
- Operating hours at high temperatures

Dependability with CLS21D

Reliability

The Memosens technology digitalizes the measured values in the sensor and transfers them to the transmitter contactlessly and free from interference potential. The result:

- An automatic error message is generated if the sensor fails or the connection between sensor and transmitter is interrupted.
- The availability of the measuring point is dramatically increased by immediate error detection.

Maintainability

Sensors with Memosens technology have integrated electronics that allow for saving calibration data and further information such as total hours of operation and operating hours under extreme measuring conditions. When the sensor is connected, the calibration data are automatically transferred to the transmitter and used to calculate the current measured value. Storing the calibration data in the sensor allows for calibration and adjustment away from the measuring point. The result:

- Sensors can be calibrated under optimum external conditions in the measuring lab. Wind and weather do neither affect the calibration quality nor the operator.
- The measuring point availability is dramatically increased by the quick and easy replacement of precalibrated sensors.
- Maintenance intervals can be defined based on all stored sensor load and calibration data and predictive maintenance is possible.
- The sensor history can be documented on external data carriers and evaluation programs at any time. Thus, the current application of the sensors can be made to depend on their previous history.

Integrity

The inductive and non-contacting measured value transmission of Memosens guarantees maximum process safety and offers the following benefits:

- All problems caused by moisture are eliminated.
 - The plug-in connection is free from corrosion.
 - Measured value distortion from moisture is not possible.
 - The plug-in system can even be connected under water.
- The transmitter is galvanically decoupled from the medium.
- EMC safety is guaranteed by screening measures for the digital measured value transmission.

Measuring system

A complete measuring system comprises:

- a CLS21 or CLS21D conductivity sensor
- a transmitter, e.g. Liquiline CM42
- a measuring cable, e.g. CYK71 or CYK10 Memosens data cable

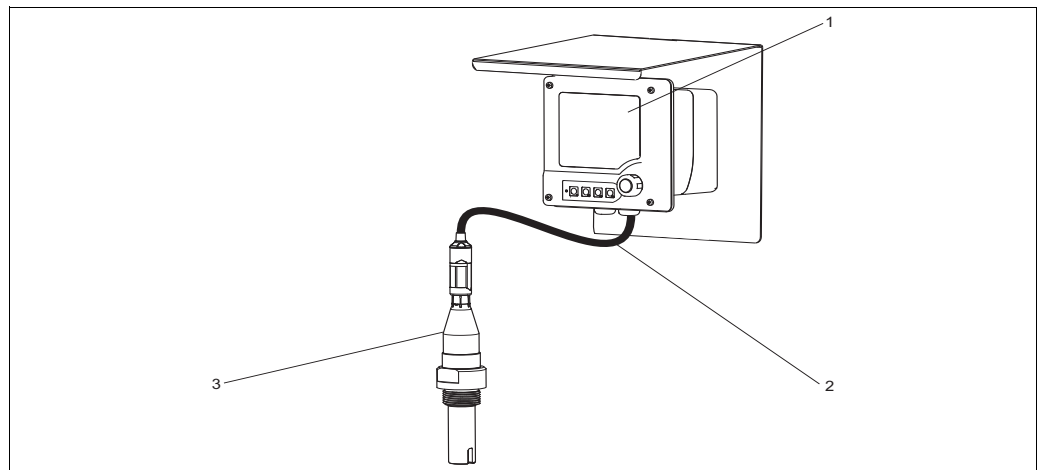

Measuring system example

- 1 *Liquiline CM42 transmitter*
- 2 *CYK10 Memosens data cable*
- 3 *Condumax CLS21D sensor*

a0003417

Input

Measured variable	<ul style="list-style-type: none"> ■ Conductivity ■ Temperature
Measuring range	<p>Conductivity (referenced to water at 25 °C (77 °F)) CLS21D and CLS21 10 µS/cm to 20 mS/cm valid in the specified temperature range specified measuring accuracy up to 100 °C (212 °F)</p> <p>Temperature CLS21D -20 to 100 °C (-4 to 212 °F) CLS21 -20 to 135 °C (-4 to 275 °F) specified measuring accuracy up to 100 °C (212 °F)</p>
Cell constant	k = 1.0 cm ⁻¹ , nominal
Temperature compensation	<p>CLS21D NTC</p> <p>CLS21 Pt 100 (class A acc. to IEC 60751)</p>

Power supply

Electrical connection **CLS15**
 The sensor is connected to the transmitter using the measuring cable CYK71 or the fixed cable.

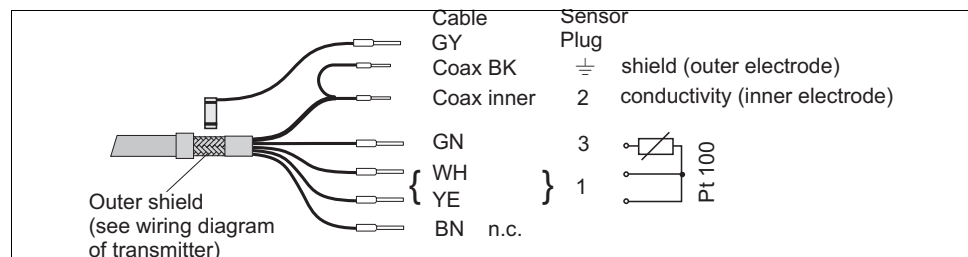

Measuring cable, CYK71 or fixed cable

CLS15D

The sensor is connected to the transmitter via the measuring cable CYK10.

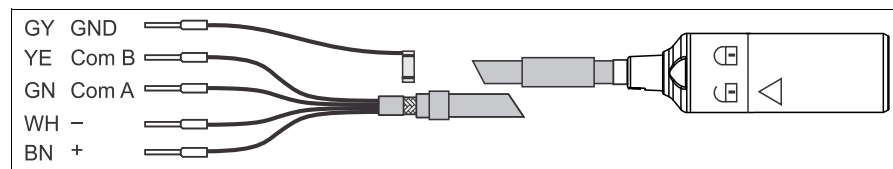

Measuring cable CYK10

Performance characteristics, in general

Measured error

Each individual sensor is factory measured in a solution of approx. 5 mS/cm on a reference measuring system referred to NIST or DKD. The accurate cell constant is entered in the supplied quality certificate. The maximum measured error in cell constant determination is 1.0 %.

Performance characteristics, CLS15D only

Conductivity response time

$t_{95} \leq 3 \text{ s}$

Temperature response time

$t_{90} \leq 296 \text{ s}$

Maximum measured error

5 % of the measured value

Repeatability

0.2 % of the measured value

Installation

Installation conditions

The sensors are mounted directly via the process connection. Optionally, they can be installed in flow assemblies.

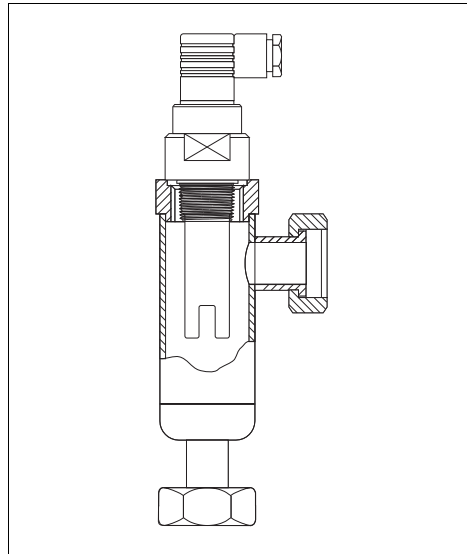

Installation in the CLA751 flow assembly

a0003418

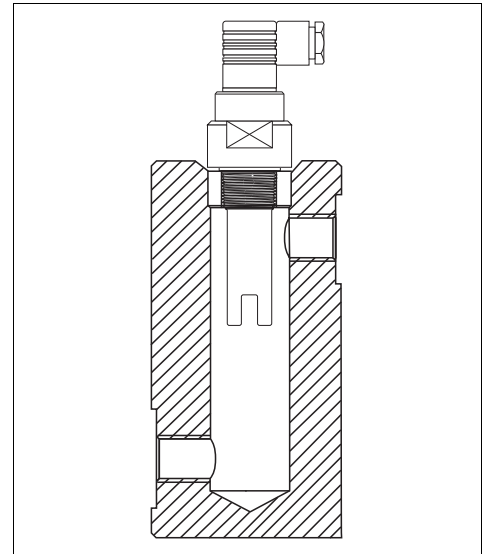

Installation in the CLA752 flow assembly

a0003422

For installation of sensors with G1 thread in tanks, the CLA111 immersion and process assembly is available (see Accessories).

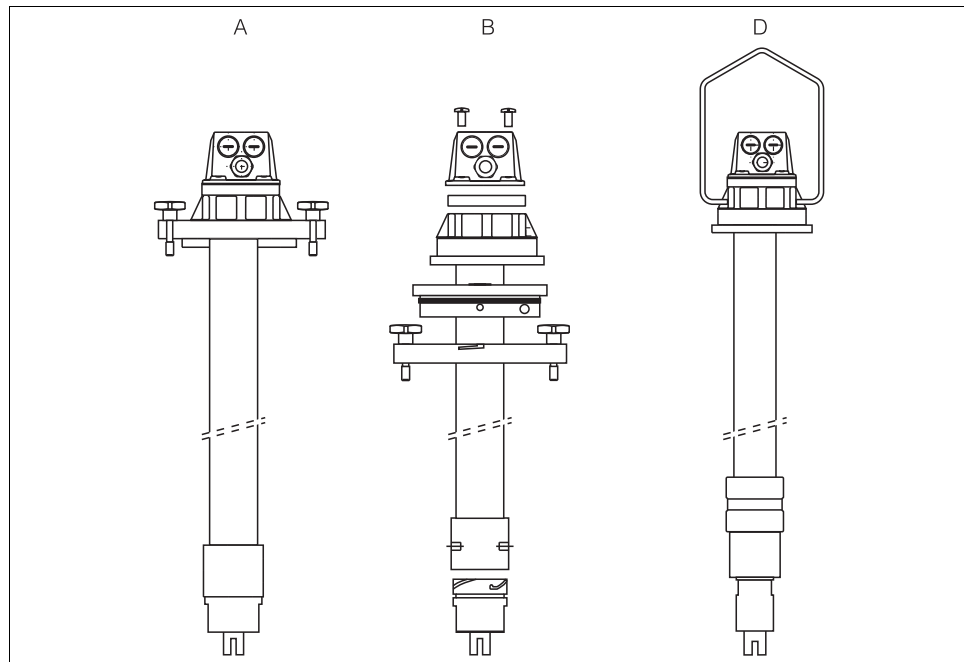

Dipfit CLA111, mounting versions A, B and D

a0003419

i The measuring surfaces must be completely immersed in the medium during operation.

Environment

Ambient temperature -20 to +60 °C (-4 to +140 °F)

Storage temperature -25 to +80 °C (-10 to +180 °F)

Humidity 5 to 95%

Protection degree

CLS21

Fixed cable version

IP 67 / NEMA 6

Plug-in head version

IP 65 / NEMA 4X

CLS21D

IP 68 / NEMA Type 6P (10 m water column, 25 °C, 168 h)

Process

Process temperature -20 to +135 °C (-4 to 275 °F) at 2.5 bar (36 psi)

i The maximum temperature for communication between Memosens sensors and the transmitter is 130 °C (266 °F).

Process pressure 16 bar (230 psi) at 20 °C (68 °F)

Pressure/temperature load curves

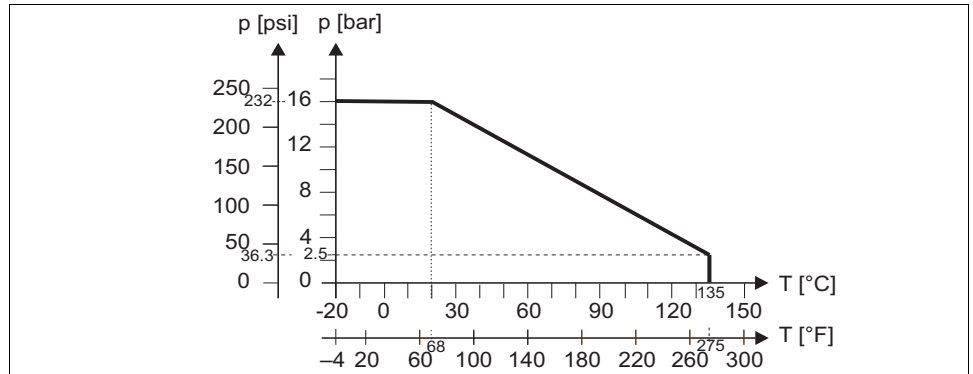

Mechanical pressure-temperature stability of

a0003425

Mechanical construction

Design, dimensions of CLS21

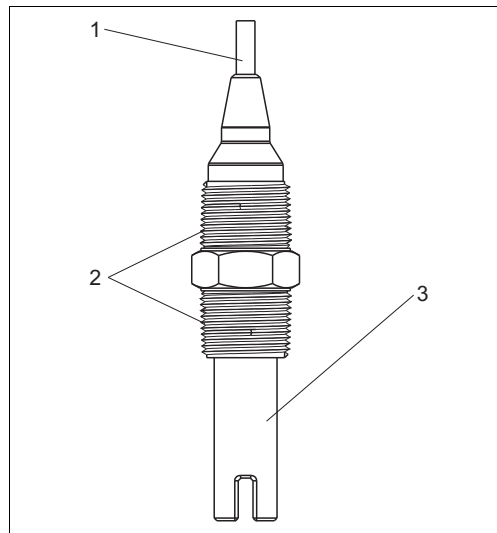

Fixed cable version with NPT 1" thread

- 1 Fixed cable
- 2 NPT 1" thread
- 3 Sensor shaft

a0003426

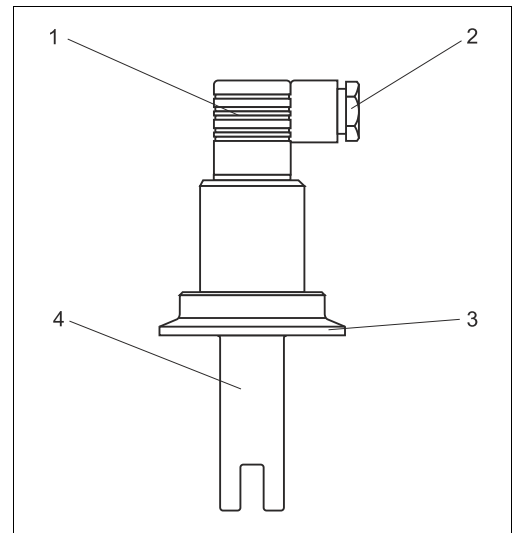

Plug-in head version with Clamp 2"

- 1 Four-pole connector
- 2 Pg 9 cable gland
- 3 2" clamp
- 4 Sensor shaft

a0003434

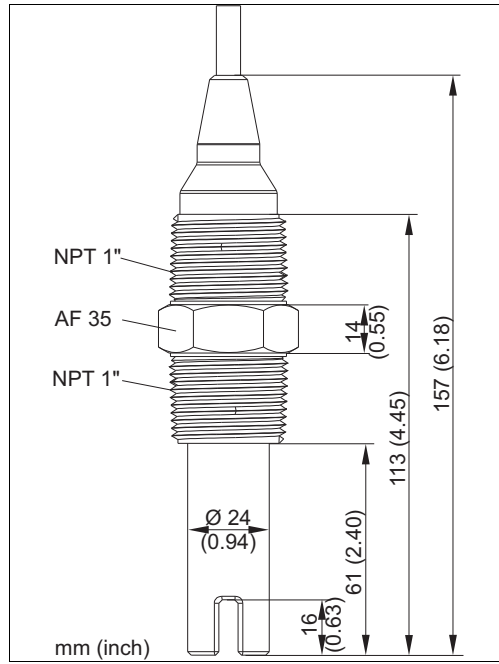

Dimensions of fixed cable version with NPT 1" thread

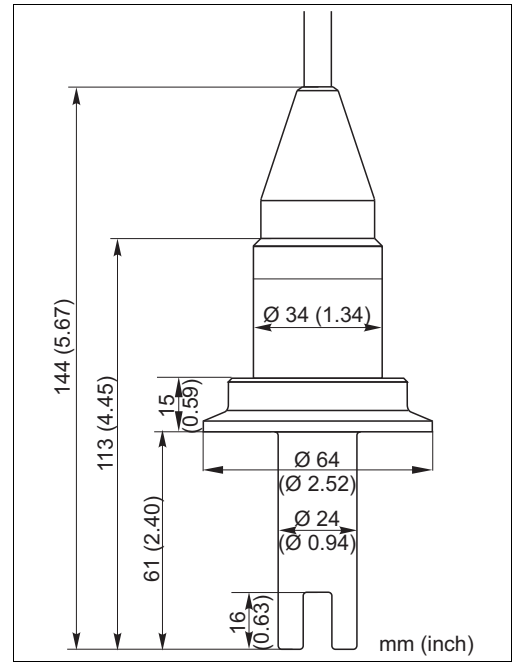

Dimensions of fixed cable version with Clamp 2"

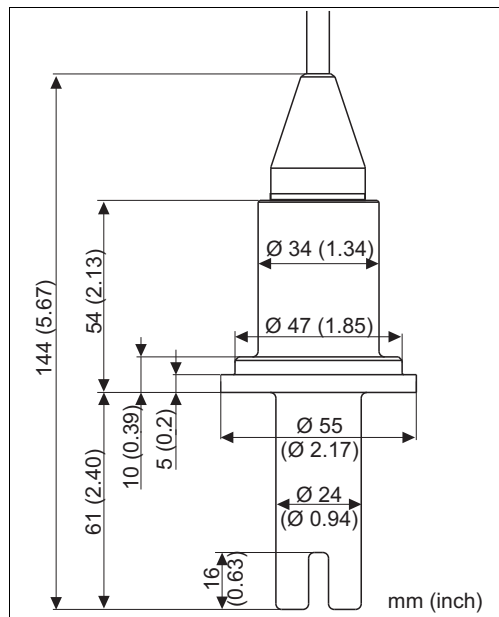

Dimensions of fixed cable version with SMS

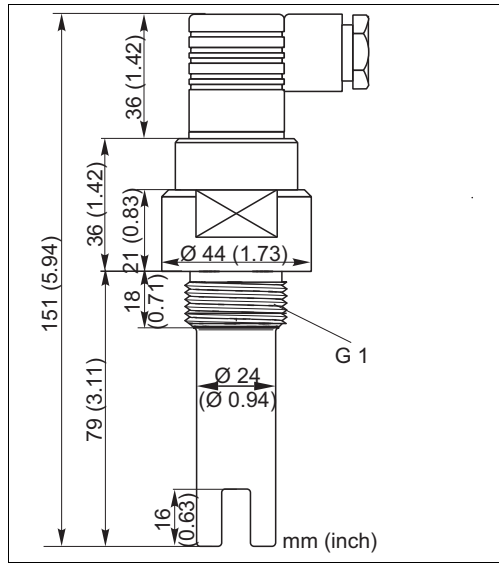

Dimensions of plug-in head version with G1 thread

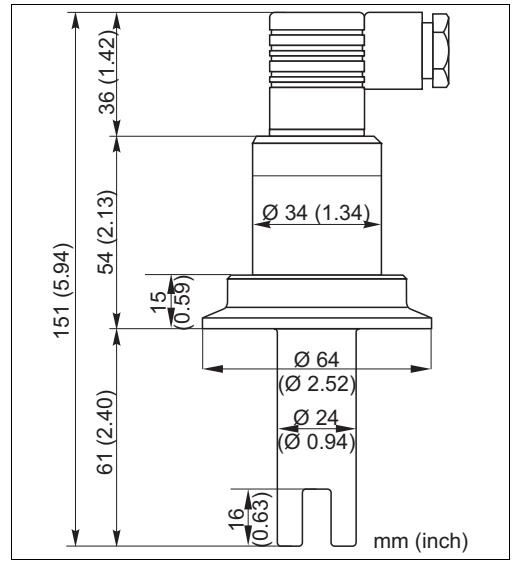

Dimensions of plug-in head version with Clamp 2"

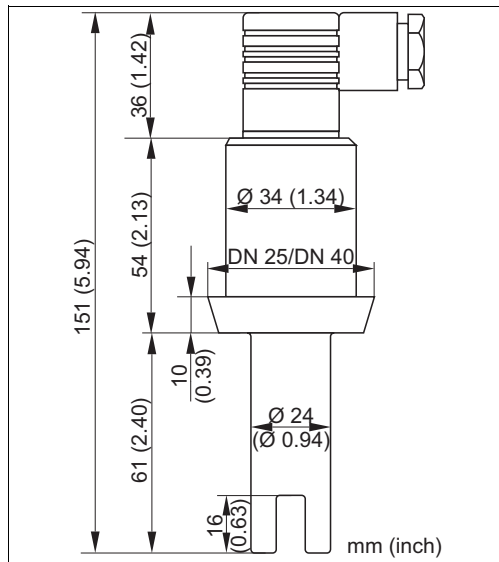

Dimensions of plug-in head version with dairy fitting

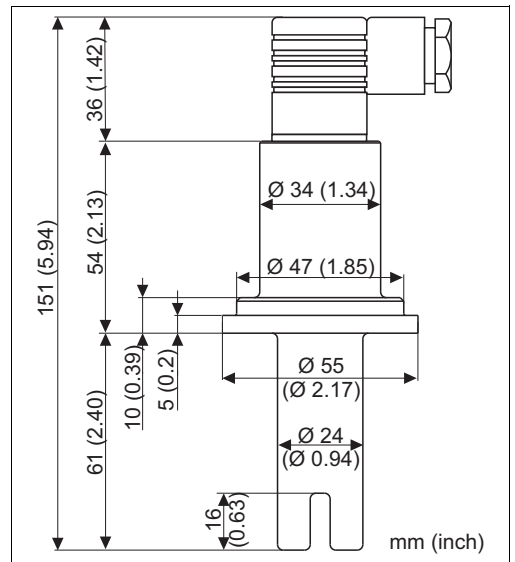

Dimensions of plug-in head version with SMS

Dimensions of CLS21D

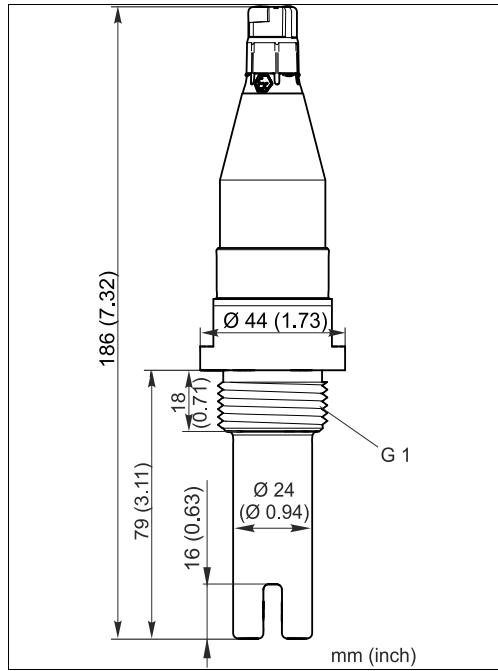

Version with G1 thread

a0007506

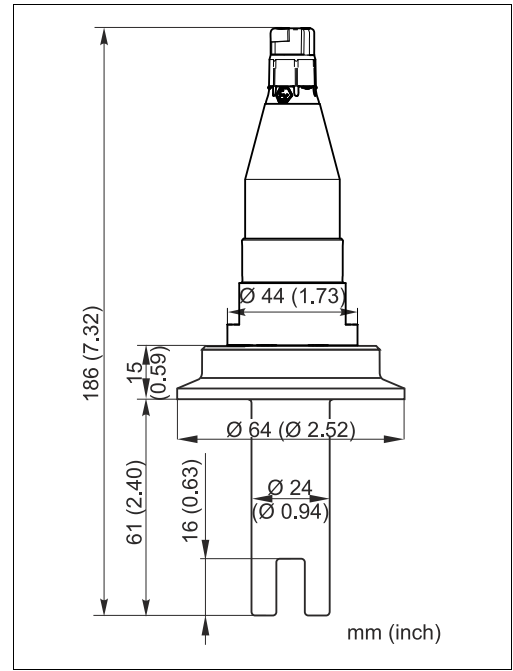

Version with 2" clamp

a0007503

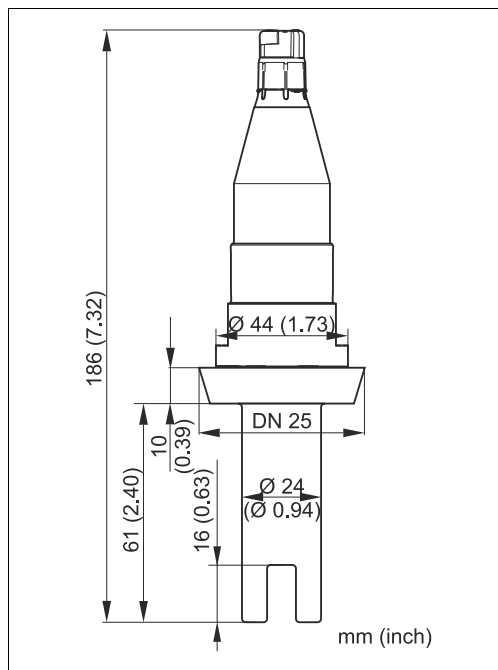

Version with dairy fitting

a0007505

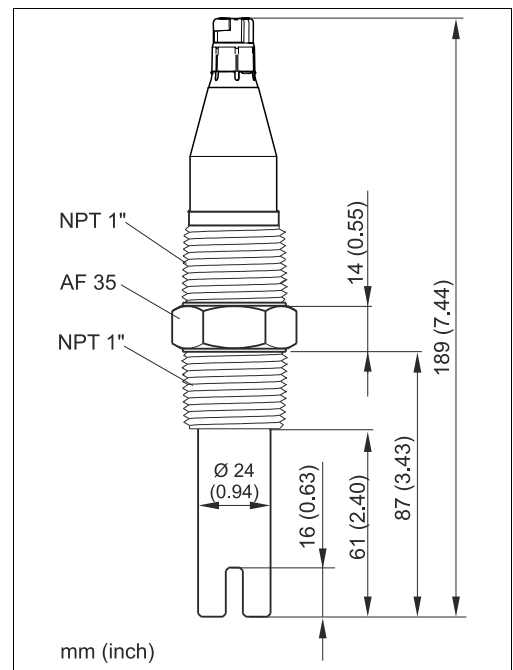

Version with NPT 1" thread

a0018973

Weight Depending on version, approx. 0.3 kg (0.7 lb.)

Material
 Electrodes: graphite
 Sensor shaft: polyether sulfone (PES-GF20)
 Thermal conductivity socket for temperature sensor: titanium 3.7035

Process connections

CLS21

Fixed cable version:
 Thread NPT 1"
 Clamp 2" acc. to ISO 2852
 SMS DN 38 (1½")

Plug-in head version:
 Thread G 1
 Clamp 2" acc. to ISO 2852
 Dairy fitting DN 25 or DN 40 acc. to DIN 11851
 SMS DN 38 (1½")

CLS21D

Thread G1
 Thread NPT 1"
 Clamp 2" acc. to ISO 2852
 Dairy fitting DN 25 acc. to DIN 11851

Clamp connection:

Sensors with clamp connections can be fixed using sheet metal brackets or solid brackets. Sheet metal brackets have a lower dimensional stability, uneven bearing surfaces causing point loads and sometimes sharp edges that can damage the clamp. We strongly recommend to always use solid brackets because of their higher dimensional stability. Solid brackets may be applied over the total pressure-temperature range (see temperature-pressure load curve).

Certificates and approvals

Ex approval

CLS21

- ATEX II 1G Ex ia IIC T3 / T4 / T6
- FM/CSA IS/NI CL I Div. 1 & 2 GP A - D in combination with the Liquiline CM42 and Mycom CLM153 transmitters

CLS21D-G**

- ATEX /NEPSI II 1G Ex ia IIC T3 / T4 / T6, IECEx Ex ia IIC T6 Ga

CLS21D-O**

- FM/CSA IS/NI CL I Div. 1 & 2 GP A - D in combination with the Liquiline CM42 transmitter

CLS21D-V**

- ATEX/NEPSI II 3G Ex nL IIC T3 / T4 / T6 for the use in Zone 2 with transmitter Liquiline CM42-KV***

 ATEX and FM/CSA versions of digital sensors with Memosens technology are indicated by an orange-red ring in the plug-in head.

Quality certificate

With statement of the individual cell constant

Ordering information

Product pages

www.products.endress.com/cls21
www.products.endress.com/cls21d

Product configurator

1. You can choose from the following options on the product page located on the right:

Product page function

- :: Add to product list
- :: Price & order information
- :: Compare this product
- :: Configure this product

2. Click "Configure this product".
3. The configurator opens in a separate window. You can now configure your device and receive the complete order code that applies for the device.
4. Afterwards, export the order code as a PDF or Excel file. To do so, click the appropriate button at the top of the page.

**Product structure
Condumax CLS21**

i The following product structure represents the status of printing. You can create a complete and valid order code on the Internet using the configurator tool.

Measuring range and cell constant			
C			Measuring range: 10.0 µS ... 20 mS/cm (k = 1)
Process connection and materials			
1E			Thread G 1, PES (plug-in head version only)
1N			Thread NPT 1", PES (fixed-cable version only)
2A			Dairy fitting DN 25, DIN 11851, PES (plug-in head version only)
2B			Dairy fitting DN 40, DIN 11851, PES (plug-in head version only)
2C			Process connection SMS DN 38, PES
3B			Clamp 2", PES
Measuring cable connection			
	2		with 5 m / 16.41 ft fixed cable
	3		with 10 m / 32.81 ft fixed cable
	4		four-pole DIN connector with Pg 9, DIN 43650-A
Temperature sensor			
	A		Integrated Pt 100 temperature sensor
	D		No temperature sensor
CLS21-			complete order code

**Product structure
Condumax CLS21D**

Measuring range and cell constant			
C			Measuring range: 10.0 µS to 20 mS/cm (k = 1)
L			PWIS-free for measuring range 10.0 µS/cm to 20 mS/cm (k = 1)
Process connection and materials			
1E			Thread G 1, PES
1N			Thread NPT 1", PES
2A			Dairy fitting DN 25, DIN 11851, PES
3B			Clamp 2", PES
Approval			
	G		ATEX/NEPSI II 1G Ex ia IIC T3/T4/T6 Ga, IECEx Ex ia IIC T6 Ga
	O		FM/CSA IS/NI Cl I Div. 1 & 2 GP A - D
	V		ATEX/NEPSI II 3G Ex nL IIC T3/T4/T6
	1		Non-hazardous areas
CLS21D-			complete order code

Accessories

 In the following sections, you find the accessories available at the time of issue of this documentation. For information on accessories that are not listed here, please contact your local service or sales center.

Connection

Measuring cables

CYK71 measuring cable

- Non-terminated cable for the connection of sensors (e.g. conductivity sensors) or the extension of sensor cables
- Sold by the meter, order numbers:
 - non-Ex version, black: 50085333
 - Ex version, blue: 50085673

CYK10 Memosens data cable

- For digital sensors with Memosens technology
pH, redox, oxygen (amperometric), chlorine, conductivity (conductive)
- Ordering as per product structure (→ online Configurator, www.products.endress.com/cyk10)

CYK11 Memosens data cable

- Extension cable for digital sensors with Memosens protocol
- Ordering as per product structure (→ Online configurator, www.products.endress.com/cyk11)

Junction boxes

Junction box VBM

- For cable extension
- 10 terminals
- Cable entries: 2 x Pg 13.5 or 2 x NPT ½"
- Material: aluminum
- Ingress protection: IP 65 (≅ NEMA 4X)
- Order numbers:
 - cable entries Pg 13.5: 50003987
 - cable entries NPT ½": 51500177

Junction box VBM-Ex

- For cable extension in hazardous areas
- 10 terminals (blue)
- Cable entries: 2 x Pg 13.5
- Material: aluminum
- Ingress protection: IP 65 (≅ NEMA 4X)
- Order no.: 50003991

Calibration solutions

Precision solutions referred to SRM (Standard Reference Material) of NIST for qualified calibration of conductivity measuring systems according to ISO, with temperature table

- CLY11-A
74 µS/cm (reference temperature 25 °C (77 °F)), 500 ml (16.9 fl.oz)
order no. 50081902
- CLY11-B
149.6 µS/cm (reference temperature 25 °C (77 °F)), 500 ml (16.9 fl.oz)
order no. 50081903
- CLY11-C
1.406 mS/cm (reference temperature 25 °C (77 °F)), 500 ml (16.9 fl.oz)
order no. 50081904
- CLY11-D
12.64 mS/cm (reference temperature 25 °C (77 °F)), 500 ml (16.9 fl.oz)
order no. 50081905

For further information on calibration solutions see Technical Information TI00162C/07/EN.

Assemblies

Dipfit CLA111

- Immersion assembly for open and closed tanks with flange DN 100
- Ordering acc. to product structure, → online configurator: www.products.endress.com/cla111
- Technical Information TI00135C/07/EN

CLA751 flow assembly

- For installation of conductivity sensors with G 1 thread.
- Inlet (bottom) and outlet (lateral) DN 20 with union nuts G 1.
- Stainless steel 1.4571 (AISI 316Ti)
- Max. temperature: 160 °C (320 °F)
- Max. pressure: 12 bar (174 psi)
- Order no.: 50004201

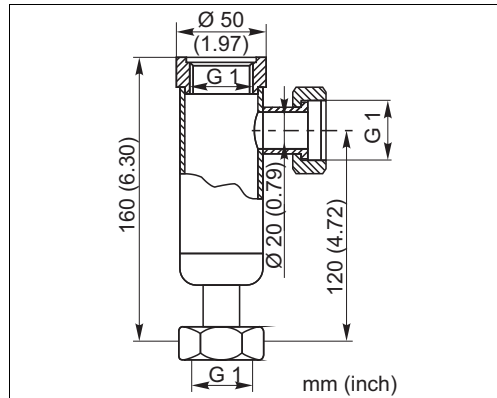

CLA751 flow assembly

CLA752 flow assembly

- For installation of conductivity sensors with G 1 thread
- Inlet (lateral) and outlet (lateral) DN 20 with G 1/2 internal thread
- Polypropylene (PP)
- Max. temperature: 90 °C (194 °F)
- Max. pressure: 6 bar (87 psi)
- Order no.: 50033772

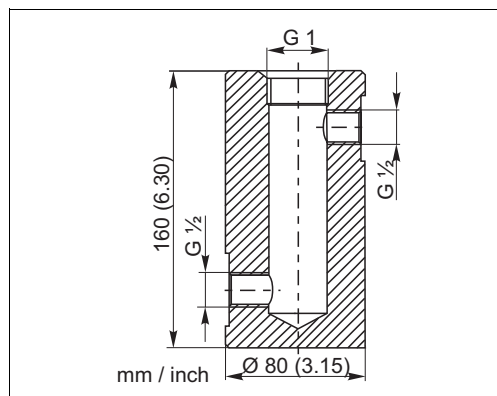

CLA752 flow assembly

Instruments International

Endress+Hauser
Instruments International AG
Kaegenstrasse 2
4153 Reinach
Switzerland

Tel.+41 61 715 81 00
Fax+41 61 715 25 00
www.endress.com
info@ii.endress.com

Endress+Hauser 
People for Process Automation