

Technical Information

RMA42

Process transmitter with control unit



Digital process transmitter for monitoring and visualizing analog measured values

Application

- Plant and apparatus engineering and construction
- Control rooms and cabinets
- Laboratories
- Process recording and supervision
- Process control
- Signal adjustment and signal conversion
- Overfill protection according to WHG

Your benefits

- 5-digit, 7-segment backlit LC display
- User-configurable dot matrix display range for bar graph, units and tag name
- 1 or 2 universal inputs
- 2 relays (optional)
- Min./max. value saved
- 1 or 2 calculated values
- One linearization table with 32 points for each calculated value
- 1 or 2 analog outputs
- Digital status output (open collector)
- Operation using 3 keys
- Configuration via interface and FieldCare or DeviceCare software

Function and system design

Application

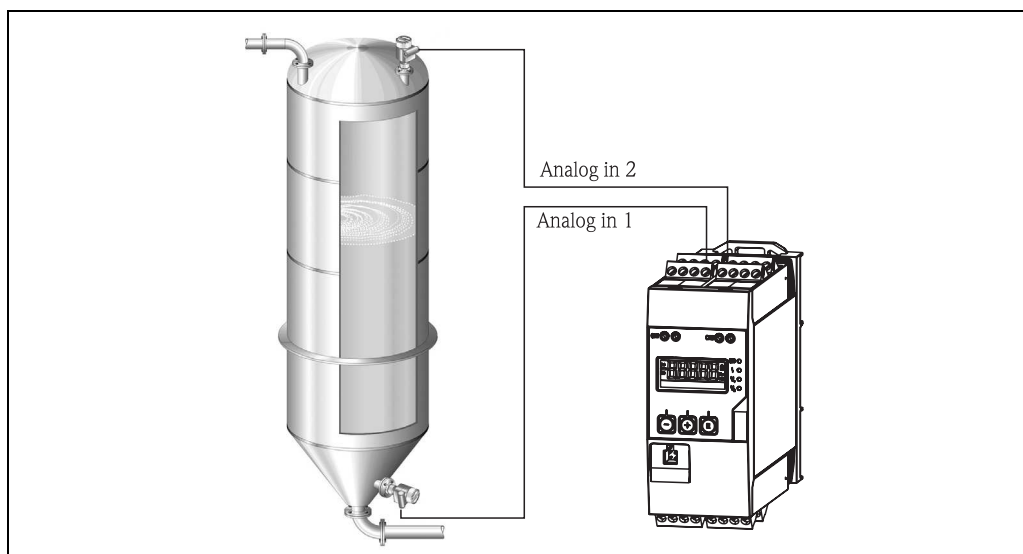

Example for "differential pressure" application

The RMA42 process transmitter powers the transmitter and processes analog signals from transmitters, particularly from the area of process instrumentation. These signals are monitored, evaluated, calculated, saved, separated, linked, converted and displayed. The signals, intermediate values and the results of calculations and analysis are transmitted by digital or analog means.

Measuring system

The RMA42 is a process transmitter, which is controlled by a microcontroller, and exhibits a display, analog inputs for process and status signals, analog and digital outputs, as well as an interface for configuration.

Connected sensors (e.g. temperature, pressure) can be powered by the integrated transmitter power supply system. The signals to be measured are converted from analog to digital signals, processed digitally in the device, and then converted from digital to analog signals and made available to the various outputs. All measured values, and values calculated in any way, are available as a signal source for the display, all outputs, relays and the interface. It is possible to make multiple use of the signals and results (e.g. a signal source as an analog output signal and limit value for a relay).

Input

Measured variable	<p>Current, voltage, resistance, resistance thermometer, thermocouples</p> <p>Calculated process variables</p> <p><i>Mathematics functions</i></p> <p>The following mathematics functions are available in RMA42:</p> <ul style="list-style-type: none"> ▪ Sum ▪ Difference ▪ Mean ▪ Linearization ▪ Multiplication <p><i>Linearization function</i></p> <p>Up to 32 user-definable points are available in the device per calculated value to linearize the input, e.g. for tank linearization. In the case of the two-channel device (option), mathematics channel M2 can be used to linearize mathematics channel M1.</p> <p>Linearization is also available in the FieldCare configuration software.</p>
Measuring ranges	<p>Current:</p> <ul style="list-style-type: none"> ▪ 0/4 to 20 mA +10% overrange ▪ Short-circuit current: max. 150 mA ▪ Load: 10 Ω <p>Voltage:</p> <ul style="list-style-type: none"> ▪ 0 to 10 V, 2 to 10 V, 0 to 5 V, 0 to 1 V, 1 to 5 V, ± 1 V ± 10 V, ± 30 V, ± 100 mV ▪ Max. permitted input voltage: <ul style="list-style-type: none"> Voltage ≥ 1 V: ± 35 V Voltage < 1 V: ± 12 V ▪ Input impedance: > 1 MΩ <p>Resistance:</p> <ul style="list-style-type: none"> ▪ 30 to 3000 Ω <p>Resistance thermometer:</p> <ul style="list-style-type: none"> ▪ Pt100 as per IEC60751, GOST, JIS1604 ▪ Pt500 and Pt1000 as per IEC60751 ▪ Cu100, Cu50, Pt50, Pt46, Cu53 as per GOST ▪ Ni100, Ni1000 as per DIN 43760 <p>Thermocouple types:</p> <ul style="list-style-type: none"> ▪ Type J, K, T, N, B, S, R as per IEC60584 ▪ Type U as per DIN 43710 ▪ Type L as per DIN 43710, GOST ▪ Type C, D as per ASTM E998
Number of inputs	One or two universal inputs
Measurement cycle	200 ms
Galvanic isolation	Towards all other circuits

Output

Output signal

One or two analog outputs, galvanically isolated

Current/voltage output

Current output:

- 0/4 to 20 mA
- Overage up to 22 mA

Voltage:

- 0 to 10 V, 2 to 10 V, 0 to 5 V, 1...5 V
- Overage: up to 11 V, short-circuit proof, $I_{\max} < 25 \text{ mA}$

Loop power supply

- Open-circuit voltage: 24 V DC (+15% /-5%)
Ex version: > 14 V at 22 mA
Non-hazardous operation: > 16 V at 22 mA
- Maximum 30 mA short-circuit-proof and overload-proof
- Galvanically isolated from system and outputs

HART®:

HART® signals are not affected

Status output

Open Collector for monitoring of the device state and alarm notification. The OC output is closed in normal state. In error state, the OC output is opened.

- $I_{\max} = 200 \text{ mA}$
- $U_{\max} = 28 \text{ V}$
- $U_{\text{on}/\max} = 2 \text{ V}$ at 200 mA

Galvanic isolation towards all other circuits; testing voltage 500 V

Limit function

Relay contact	Changeover
Maximum contact burden DC	30 V / 3 A (permanent state, without destruction of the input)
Maximum contact burden AC	250 V / 3 A (permanent state, without destruction of the input)
Minimum contact load	500 mW (12 V/10 mA)
Galvanic isolation towards all other circuits	Test voltage 1500V AC
Switching cycles	> 1 million

Power supply

Terminal assignment

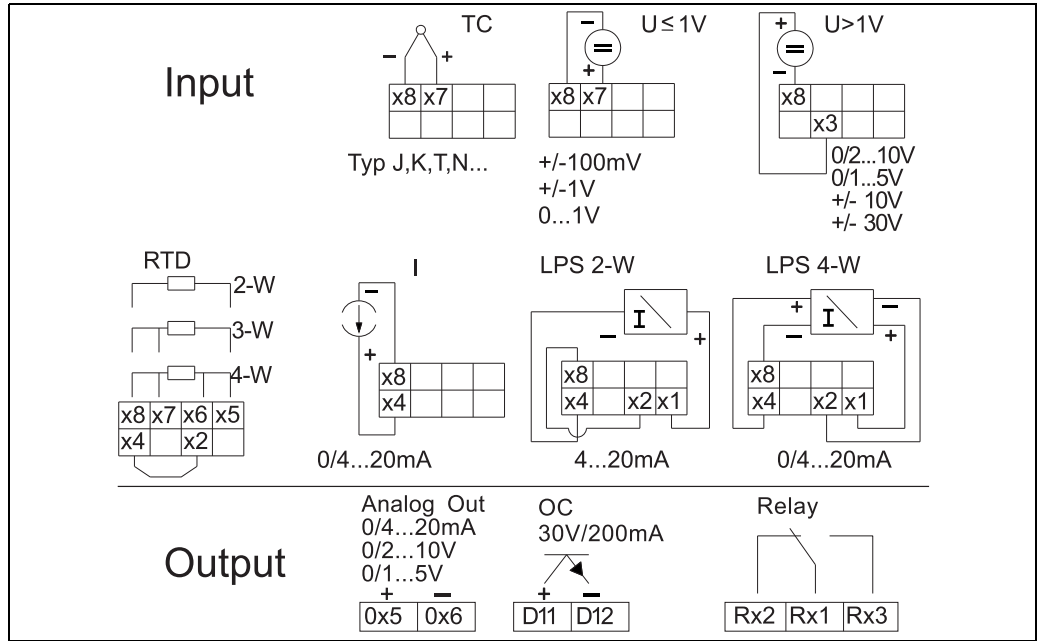

Terminal assignment of the process transmitter (relays (terminals Rx1-Rx3) and channel 2 (terminals 21-28 and O25/O26) are optional)

Supply voltage	Wide-range power supply unit 24 to 230 V AC/DC (-20 % / +10 %) 50/60 Hz
Power consumption	Max. 21.5 VA / 6.9 W
Power loss	<ul style="list-style-type: none"> 1-channel version: max. 2.8 W 2-channel version: max. 5.3 W
Connection data interface	<p>Commubox FXA291 PC USB interface</p> <ul style="list-style-type: none"> Connection: 4-pin connector Transmission protocol: FieldCare Transmission rate: 38,400 Baud <p>Interface cable TXU10-AC PC USB interface</p> <ul style="list-style-type: none"> Connection: 4-pin connection Transmission protocol: FieldCare Delivery scope: Interface cable incl. FieldCare Device Setup DVD with all Comm DTMs and Device DTMs <p>HART®</p> <ul style="list-style-type: none"> Connection sockets on the front of the device Internal communication resistor

Performance characteristics

Reference operating conditions

Power supply: 230 V AC, 50/60 Hz
Ambient temperature: 25 °C ± 5 °C (77 °F ± 9 °F)
Humidity: 20 % to 60 % rel. humidity

Maximum measured error Universal input:

Accuracy	Input:	Range:	Maximum measured error of measuring range (oMR):
	Current	0 to 20 mA, 0 to 5 mA, 4 to 20 mA; overrange: to 22 mA	± 0.05%
	Voltage ≥ 1 V	0 to 10 V, 2 to 10 V, 0 to 5 V, 1 to 5 V, 0 to 1 V, ± 1 V, ± 10 V, ± 30 V	± 0.1%
	Voltage < 1 V	± 100 mV	± 0.05%
	Resistance measurement	30 to 3000 Ω	4-wire: ± (0.10% oMR + 0.8 Ω) 3-wire: ± (0.10% oMR + 1.6 Ω) 2-wire: ± (0.10% oMR + 3 Ω)
	Resistance thermometer	Pt100, -200 to 850 °C (-328 to 1562 °F) (IEC60751, α=0.00385) Pt100, -200 to 850 °C (-328 to 1562 °F) (JIS1604, w=1.391) Pt100, -200 to 649 °C (-328 to 1200 °F) (GOST, α=0.003916) Pt500, -200 to 850 °C (-328 to 1562 °F) (IEC60751, α=0.00385) Pt1000, -200 to 600 °C (-328 to 1112 °F) (IEC60751, α=0.00385)	4-wire: ± (0.10% oMR + 0.3 K (0.54 °F)) 3-wire: ± (0.10% oMR + 0.8 K (1.44 °F)) 2-wire: ± (0.10% oMR + 1.5 K (2.7 °F))
		Cu100, -200 to 200 °C (-328 to 392 °F) (GOST, w=1.428) Cu50, -200 to 200 °C (-328 to 392 °F) (GOST, w=1.428) Pt50, -200 to 1100 °C (-328 to 2012 °F) (GOST, w=1.391) Pt46, -200 to 850 °C (-328 to 1562 °F) (GOST, w=1.391) Ni100, -60 to 250 °C (-76 to 482 °F) (DIN43760, α=0.00617) Ni1000, -60 to 250 °C (-76 to 482 °F) (DIN43760, α=0.00617)	4-wire: ± (0.20% oMR + 0.3 K (0.54 °F)) 3-wire: ± (0.20% oMR + 0.8 K (1.44 °F)) 2-wire: ± (0.20% oMR + 1.5 K (2.7 °F))
	Thermocouples	Cu53, -50 to 200 °C (-58 to 392 °F) (GOST, w=1.426)	4-wire: ± (0.30% oMR + 0.3 K (0.54 °F)) 3-wire: ± (0.30% oMR + 0.8 K (1.44 °F)) 2-wire: ± (0.30% oMR + 1.5 K (2.7 °F))
		Type J (Fe-CuNi), -210 to 1200 °C (-346 to 2192 °F) (IEC60584)	± (0.1% oMR + 0.5 K (0.9 °F)) from -100 °C (-148 °F)
		Type K (NiCr-Ni), -200 to 1372 °C (-328 to 2502 °F) (IEC60584)	± (0.1% oMR + 0.5 K (0.9 °F)) from -130 °C (-202 °F)
		Type T (Cu-CuNi), -270 to 400 °C (-454 to 752 °F) (IEC60584)	± (0.1% oMR + 0.5 K (0.9 °F)) from -200 °C (-328 °F)
		Type N (NiCrSi-NiSi), -270 to 1300 °C (-454 to 2372 °F) (IEC60584)	± (0.1% oMR + 0.5 K (0.9 °F)) from -100 °C (-148 °F)
		Type L (Fe-CuNi), -200 to 900 °C (-328 to 1652 °F) (DIN43710, GOST)	± (0.1% oMR + 0.5 K (0.9 °F)) from -100 °C (-148 °F)
		Type D (W3Re/W25Re), 0 to 2495 °C (32 to 4523 °F) (ASTME998)	± (0.15% oMR + 1.5 K (2.7 °F)) from 500 °C (from 932 °F)
		Type C (W5Re/W26Re), 0 to 2320 °C (32 to 4208 °F) (ASTME998)	± (0.15% oMR + 1.5 K (2.7 °F)) from 500 °C (932 °F)
		Type B (Pt30Rh-Pt6Rh), 0 to 1820 °C (32 to 3308 °F) (IEC60584)	± (0.15% oMR + 1.5 K (2.7 °F)) from 600 °C (1112 °F)
		Type S (Pt10Rh-Pt), -50 to 1768 °C (-58 to 3214 °F) (IEC60584)	± (0.15% oMR + 3.5 K (6.3 °F)) for -50 to 100 °C (-58 to 212 °F) ± (0.15% oMR + 1.5 K (2.7 °F)) for 100 to 1768 °C (212 to 3214 °F)
	Type R (Pt13Rh-Pt), -50 to 1768 °C (-58 to 3214 °F) (IEC60584)	± (0.15% oMR + 3.5 K (6.3 °F)) for -50 to 100 °C (-58 to 212 °F) ± (0.15% oMR + 1.5 K (2.7 °F)) for 100 to 1768 °C (212 to 3214 °F)	
	Type U (Cu-CuNi), -200 to 600 °C (-328 to 1112 °F) (DIN 43710)	± (0.15% oMR + 0.5 K (0.9 °F)) from -100 °C (-148 °F)	

AD converter resolution	16 bit
Temperature drift	Temperature drift: $\leq 0.01\%/K$ ($0.1\%/18\text{ }^\circ\text{F}$) oMR $\leq 0.02\%/K$ ($0.2\%/18\text{ }^\circ\text{F}$) oMR for Cu100, Cu50, Cu53, Pt50 and Pt46

Analog output:

Current	0/4 to 20 mA, overrange to 22 mA	$\pm 0.05\%$ of measuring range
	Max. load	500 Ω
	Max. inductance	10 mH
	Max. capacitance	10 μF
	Max. ripple	10 mVpp at 500 Ω , frequency < 50 kHz
Voltage	0 to 10 V, 2 to 10 V 0 to 5 V Overrange: up to 11 V, short-circuit proof, $I_{\text{max}} < 25\text{ mA}$	$\pm 0.05\%$ of measuring range $\pm 0.1\%$ of measuring range
	Max. ripple	10 mVpp at 1000 Ω , frequency < 50 kHz
Resolution	13 bit	
Temperature drift	0.01%/K (0.1%/18 $^\circ\text{F}$) of of measuring range	
Galvanic isolation	Testing voltage of 500 V towards all other circuits	

Installation

Installation instructions**Mounting location**

Mounting on top-hat rail as per IEC 60715.

Orientation

Vertical or horizontal.

NOTICE**Heat accumulation when installing several devices on a vertically mounted top-hat rail**

- Keep sufficient gaps between the individual devices.

Environment

Ambient temperature range

Non-Ex/Ex devices: -20 to $+60\text{ }^\circ\text{C}$ (-4 to $140\text{ }^\circ\text{F}$)

UL devices: -20 to $50\text{ }^\circ\text{C}$ (-4 to $122\text{ }^\circ\text{F}$)

To avoid heat accumulation, always make sure the device is sufficiently cooled.

If the device is operated in the upper temperature limit range, this reduces the operating life of the display.

Storage temperature

-40 to $+85\text{ }^\circ\text{C}$ (-40 to $185\text{ }^\circ\text{F}$)

Operating height

< 2000 m above MSL (6561 ft)

Climate class

As per IEC 60654-1, Class B2

Degree of protection

Top-hat rail housing IP 20

Condensation

Not permitted

Electrical safety Protection class II, overvoltage category II, pollution level 2

Electromagnetic compatibility (EMC)

- Interference immunity:
To IEC 61326 industrial environments / NAMUR NE 21
- Interference emissions:
To IEC 61326 Class A

Mechanical construction

Design, dimensions

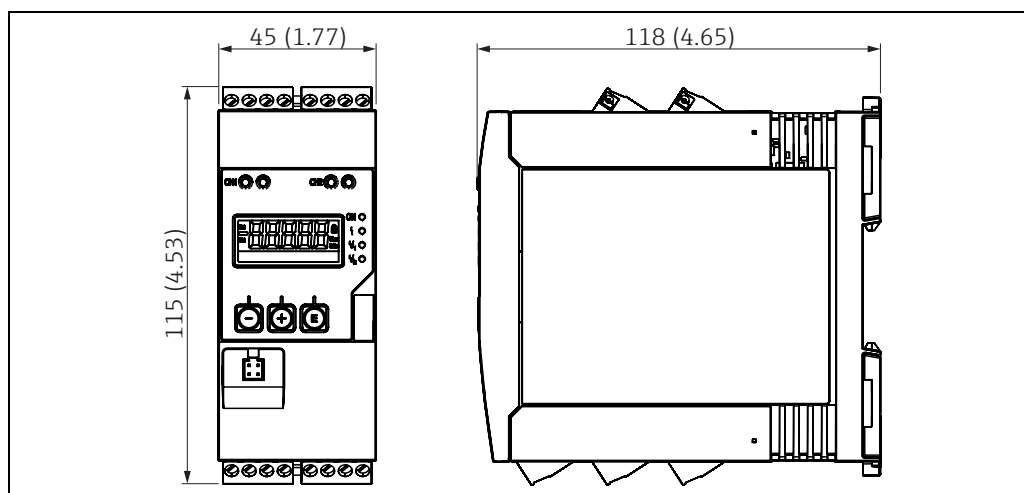

Dimensions of the process transmitter in mm (in)

a0011792

Weight Approx. 300 g (10.6 oz)

Material

- Housing: plastic PC-GF10

Terminals Screw terminals, plug-in; 2.5 mm² (30-12 AWG; torque 0.5-0.6 Nm (4.4-5.3 lb in))

Operability

Local operation

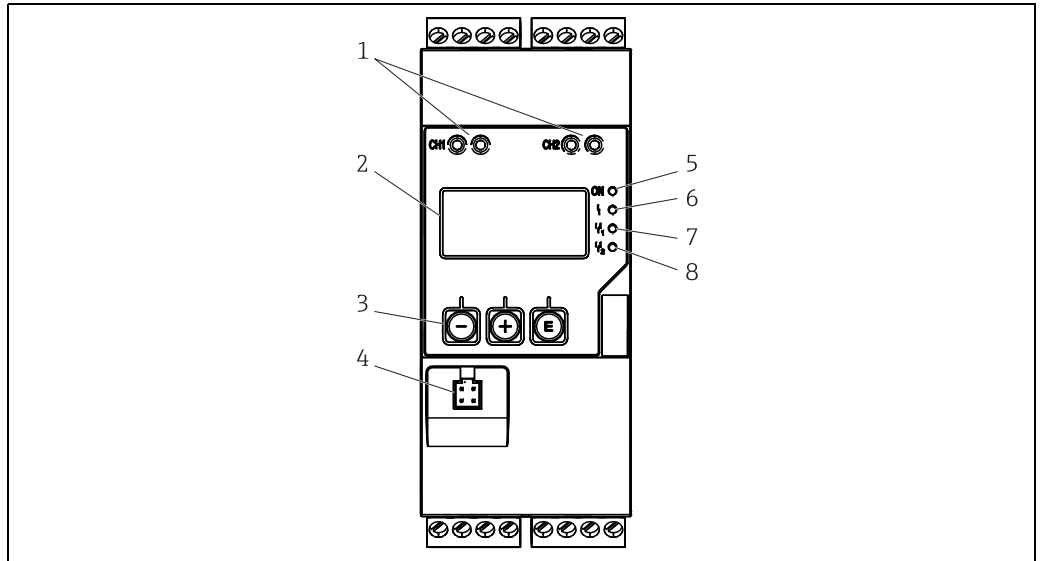

Display and operating elements of the process transmitter

a0011767

- 1: HART® connection sockets
- 2: Display
- 3: Operating keys
- 4: PC interface connection port
- 5: Green LED; on = supply voltage applied
- 6: Red LED; on = error/alarm
- 7: Yellow LED; on = relay 1 energized
- 8: Yellow LED; on = relay 2 energized

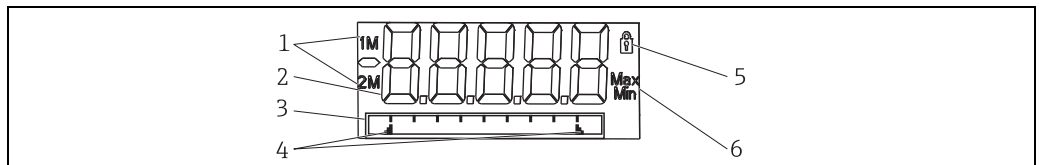

Display of the process transmitter

a0011765

- 1: Channel display: 1: analog input 1; 2: analog input 2; 1M: calculated value 1; 2M: calculated value 2
- 2: Measured value display
- 3: Dot matrix display for TAG, bar graph and unit
- 4: Limit value indicators in the bar graph
- 5: "Operation locked" indicator
- 6: Minimum/maximum value indicator

- Display
 - 5-digit, 7-segment backlit LC display
 - Dot matrix for text/bar graph
- Display range
 - 99999 to +99999 for measured values
- Signaling
 - Setup security locking (lock)
 - Measuring range overshoot/undershoot
 - 2 x status relay (only if relay option was selected)

Operating elements

3 keys: -, +, E

Remote operation**Configuration**

The device can be configured with the PC software or on site using the operating keys. FieldCare Device Setup is delivered together with the Commubox FXA291 or TXU10-AC (see 'Accessories') or can be downloaded free of charge from www.endress.com.

Interface

4-pin socket for the connection with a PC via Commubox FXA291 or TXU10-AC interface cable (see 'Accessories')

Certificates and approvals

CE mark	The device meets the legal requirements of the EU directives. Endress+Hauser confirms that the device has been tested successfully by affixing the CE mark.
Ex approval	Information about currently available Ex versions (ATEX, FM, CSA, etc.) can be supplied by your E+H Sales Center on request. All explosion protection data are given in a separate documentation which is available upon request.
UL	UL listed (optional)
Functional safety	SIL2 (optional)
Power plant	Seismic test acc. to KTA3505 (optional)
Overspill protection	Acc. to German WHG (optional)
Marine certificate	GL Marine certificate (optional)
Other standards and guidelines	<ul style="list-style-type: none"> ▪ IEC 60529: Degrees of protection by housing (IP code) ▪ IEC 61010-1: 2001 Cor 2003 Safety requirements for electrical equipment for measurement, control and laboratory use ▪ EN 60079-11 Explosive atmospheres - Part 11: equipment protection by intrinsic safety "I"

Ordering information

Detailed ordering information is available from the following sources:

- In the Product Configurator on the Endress+Hauser website: www.endress.com → Select country → Instruments → Select device → Product page function: Configure this product
- From your Endress+Hauser Sales Center: www.endress.com/worldwide



Product Configurator - the tool for individual product configuration

- Up-to-the-minute configuration data
- Depending on the device: Direct input of measuring point-specific information such as measuring range or operating language
- Automatic verification of exclusion criteria
- Automatic creation of the order code and its breakdown in PDF or Excel output format
- Ability to order directly in the Endress+Hauser Online Shop

Accessories

PC operating software

FieldCare

Interface cable

Order No.	Name
FXA291	Commubox FXA291 incl. FieldCare Device Setup and DTM library
TXU10-AC	Commubox TXU10 incl. FieldCare Device Setup and DTM library

Documentation

- Overview brochure: System components - Indicators with control unit for field and panel mounting, power supplies, barriers, transmitters, energy managers and surge arresters: FA00016K/09
- Operating Instructions for 'Process transmitter RMA42': BA00287R/09
- Ex documentation:
 - ATEX II (1)G [Ex ia] IIC, ATEX II (1)D [Ex ia] IIIC: XA00095R/09/A3
 - FM AIS ANI Control Drawing: ZD00082R/09/EN
 - CSA AIS, ANI, NI Control Drawing: ZD00083R/09/EN
- SIL - Functional Safety Manual: SD00025R/09

www.addresses.endress.com
