

Technical Information

Liquisys M CLM223/253

Conductivity/Resistivity Measurement

Transmitter for conductive and inductive sensors



Application

- Ultrapure water
- Water treatment
- Ion exchanger, reverse osmosis
- Cooling water desalinization
- Sewage

Your benefits

- Field or panel-mounted housing
- Universal application
- Simple handling
 - Logically arranged menu structure
 - Ultrasimple two-point calibration
- Safe operation
 - Overvoltage (lightning) protection
 - Manual contact control and user-defined alarm configuration

The basic unit can be extended with:

- 2 or 4 additional contacts for use as:
 - Limit contacts (also for temperature)
 - P(ID) controller
 - Timer for simple rinse processes
 - Complete cleaning with Chemoclean
- Plus package:
 - User defined current output characteristics
 - Ultrapure water monitoring acc. to USP (United States Pharmacopeia) and EP (European Pharmacopoeia) (conductive)
 - Polarization detection (conductive)
 - Concentration measurement
 - Process Check System (PCS): live check of the sensor
- HART or PROFIBUS-PA/-DP
- 2nd current output for temperature, main measured value or actuating variable
- Current input for flow rate monitoring with controller shut off or for feedforward control

Function and system design

Features of the basic version

Conductive or inductive

Two instrument versions for measurement with conductive (two electrode) sensors or inductive sensors are available. The use of inductive sensors that are less sensitive to soiling than conductive sensors is recommended for high conductivity measurement, concentration measurement or adhering media.

Measuring of conductivity and resistivity (conductive)

This is selected via the menu. During measurement, the value measured can be displayed in the other measuring mode. The temperature is displayed at the same time or, if desired, not shown at all.

Temperature compensation

The following temperature compensation selections are available:

- Linear
- NaCl curve according to IEC 746
- Ultrapure water NaCl (neutral compensation)
- Ultrapure water HCl (acid compensation, also ammonia)

The **reference temperature** is user defined, the standard value is 25 °C (77 °F).

Configuration

Different alarms are required depending on application and operator. Therefore the transmitter permits independent **configuration of the alarm contact and error current** for each individual error. Unnecessary or undesirable alarms can be suppressed in this manner. **Up to four contacts Up to two contacts** can be used as limit contacts (also for temperature), to implement a P(ID) controller or for cleaning functions.

Direct **manual operation of the contacts** (bypassing the menu) provides quick access to limit, control or cleaning contacts, permitting speedy correction of deviations.

The **serial numbers** of the instrument and modules and the order code can be called up on the display. The cell constant can be edited and even **calibrated** for demanding special applications.

Additional functions of the plus package

Current output configuration

In order to output wide measuring ranges while still achieving a high resolution in specific ranges, the **current output** can be configured as required via a table. This permits **bilinear** or **quasi-logarithmic** curves, etc.

Polarization detection

Polarization effects in the boundary layer between the sensor and the medium to be measured limit the measuring range of conductive conductivity sensors.

The transmitter can detect polarization effects using an innovative, intelligent signal evaluation process.

Live check

The live check issues an alarm when the sensor signal does not change over a defined period of time. This may be caused by blocking, passivation, separation from the process, etc.

Ultrapure water monitoring acc. to USP (United States Pharmacopeia) and EP (European Pharmacopoeia)

Ultrapure water monitoring according to USP <645> and EP means that the uncompensated conductivity and the temperature are measured and compared to a table.

The transmitter (conductive with additional contacts) comes with the following functions:

- Monitoring of "Water for Injection" (WFI) according to USP and EP
- Monitoring of "Highly Purified Water" (HPW) according to EP
- Monitoring of "Purified Water" (PW) according to EP

The **user-adjustable pre-alarm** indicates undesirable operating values in due time. Full compliance with USP or EP requires the use of a precisely calibrated sensor, for example, the CLS16.

Concentration measurement

The conversion from conductivity to concentration is effected using four user-definable **concentration curves**. This permits concentrations to be displayed in %, ppm, mg/l or TDS (total dissolved solids).

Adaptive calibration for determination of the installation factor (inductive)

Inductive measuring sensors must normally be installed in pipes at a required minimum distance from the pipe wall. If this minimum distance is not observed, the measured value changes. The built-in adaptive calibration using the installation factor allows you to compensate for this once the sensor is installed.

Second current output

The second current output can be configured for temperature, main measured value (conductivity, resistivity, concentration) or actuating variable.

Current input

The current input of the transmitter allows two different applications: controller shut-down in case of lower flow rate violation or total failure in the main flow as well as feedforward control. Both functions are also combinable.

Measuring system

A complete measuring systems comprises:

- The transmitter Liquisys M CLM223 or CLM253
- A sensor with or without an integrated temperature sensor
- A measuring cable CYK71 (conductive), CPK9 for Condumax H CLS16 or CLK5 (inductive)

Options: extension cable, junction box VBM

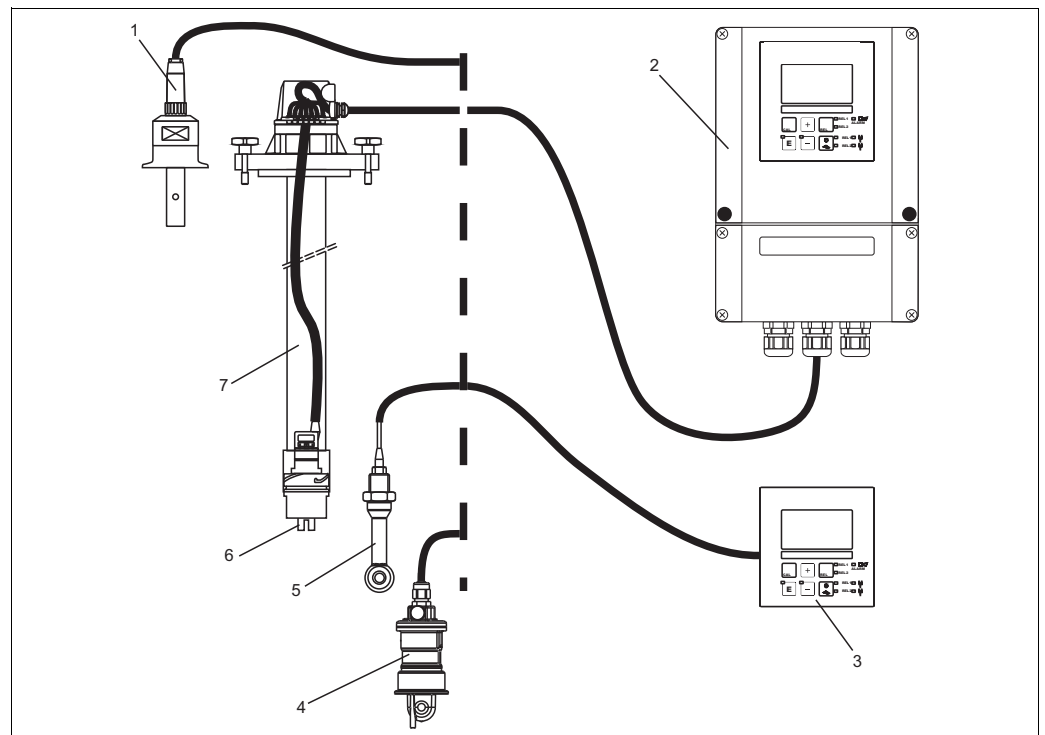

Complete measuring system Liquisys M CLM223/253

- | | | | |
|---|-------------------------|---|---------------------------|
| 1 | Conductive sensor CLS15 | 5 | Inductive sensor CLS50 |
| 2 | Liquisys M CLM253 | 6 | Conductive sensor CLS21 |
| 3 | Liquisys M CLM223 | 7 | Immersion assembly CLA111 |
| 4 | Inductive sensor CLS54 | | |

a0008937

Input

Measured variables	Conductivity, resistivity, temperature	
Measuring range	Conductivity (conductive):	0 to 600 mS/cm (uncompensated)
	Conductivity (inductive):	0 to 2000 mS/cm (uncompensated)
	Resistivity:	0 to 200 M Ω ·cm
	Concentration:	0 to 9999 (% , ppm, mg/l, TDS)
	Temperature:	-35 to +250 °C (-31 to +482 °F)
Cable specification	Cable length (conductive):	conductivity: max. 100 m (328 ft) (CYK71) resistivity: max 15 m (49 ft) (CYK71)
	Cable length (inductive):	max 55 m (180 ft) (CLK5)
	Cable resistance CYK71:	165 Ω /km (conductivity measurement)
Cell constant	Adjustable cell constant:	k = 0.0025 to 99.99 cm ⁻¹
Temperature sensors	Pt 100, Pt 1000, NTC 30K	
Measuring frequency	Conductivity, resistivity (conductive):	170 Hz to 2 kHz
	Conductivity (inductive):	2 kHz
Binary inputs	Voltage:	10 to 50 V
	Power consumption:	max. 10 mA
Current input	4 to 20 mA, galvanically separated	
	Load: 260 Ω at 20 mA (voltage drop 5.2 V)	

Output

Output signal 0/4 to 20 mA, galvanically separated, active

HART	
Signal coding	Frequency Shift Keying (FSK) + 0.5 mA via current output signal
Data transfer rate	1200 Baud
Galvanic isolation	yes

PROFIBUS PA	
Signal coding	Manchester Bus Powered (MBP)
Data transfer rate	31.25 kBit/s, voltage mode
Galvanic isolation	yes (IO-Module)

PROFIBUS DP	
Signal coding	RS485
Data transfer rate	9.6 kBd, 19.2 kBd, 93.75 kBd, 187.5 kBd, 500 kBd, 1.5 MBd
Galvanic isolation	yes (IO-Module)

Signal on alarm 2.4 or 22 mA in case of an error

Load maximum 500 Ω

Linearization transmission behaviour

Conductivity:	adjustable
Resistivity:	adjustable
Concentration:	adjustable
Actuating variable:	adjustable
Temperature:	adjustable

Resolution max. 700 digits/mA

Min. distance for 0 / 4 to 20 mA signal

Conductivity:		
Measured value 0 to 1.999 $\mu\text{S/cm}$	0.2 $\mu\text{S/cm}$	
Measured value 0 to 19.99 $\mu\text{S/cm}$	2 $\mu\text{S/cm}$	
Measured value 20 to 199.9 $\mu\text{S/cm}$	20 $\mu\text{S/cm}$	
Measured value 200 to 1999 $\mu\text{S/cm}$	200 $\mu\text{S/cm}$	
Measured value 2 to 19.99 mS/cm	2 mS/cm	
Measured value 20 to 2000 mS/cm	20 mS/cm	
Resistivity		
Measured value 0 to 199.9 k Ωcm	20 k Ωcm	
Measured value 200 to 1999 k Ωcm	200 k Ωcm	
Measured value 2 to 19.99 M Ωcm	2.0 M Ωcm	
Measured value 20 to 200 M Ωcm	20 M Ωcm	
Concentration		no minimum distance
Temperature		15 °C

Isolation voltage max. 350 V_{RMS}/500 V DC

Overvoltage protection according to EN 61000-4-5

Auxiliary voltage output	Output voltage: Output current:	15 V \pm 0.6 max. 10 mA
Contact outputs	Switching current with ohmic load ($\cos \varphi = 1$): Switching current with inductive load ($\cos \varphi = 0.4$): Switching voltage: Switching power with ohmic load ($\cos \varphi = 1$): Switching power with inductive load ($\cos \varphi = 0.4$):	max. 2 A max. 2 A max. 250 V AC, 30 V DC max. 500 VA AC, 60 W DC max. 500 VA AC, 60 W DC
Limit contactor	Pickup/dropout delay:	0 to 2000 s
Controller	Function (adjustable): Controller response: Control gain K_p : Integral action time T_n : Derivative action time T_v : Period for pulse length controller: Frequency for pulse frequency controller: Basic load:	pulse length/pulse frequency controller PID 0.01 to 20.00 0.0 to 999.9 min 0.0 to 999.9 min 0.5 to 999.9 s 60 to 180 min^{-1} 0 to 40% of max. set value
Alarm	Function (selectable): Alarm threshold adjustment range: Alarm delay:	Latching/momentary contact Conductivity, resistivity, concentration, temperature, USP, EP: complete measuring range 0 to 2000 s (min)

Protocol specific data

HART	
Manufacturer ID	11 _h
Device type code	0092 _h (ind. measured), 0093 _h (cond. measured)
Transmitter specific revision	0001 _h
HART specification	5.0
DD files	www.products.endress.com/hart
Load HART	250 Ω
Device variables	None (dynamic variables PV, SV, only)
Features supported	-

PROFIBUS PA	
Manufacturer ID	11 _h
Ident number	1515 _h
Device revision	11 _h
Profile version	2.0
GSD files	www.products.endress.com/profibus
GSD file version	
Output values	Main value, temperature value
Input values	Display value of PLC
Features supported	Device locking: The device can be locked by hardware or software.

PROFIBUS DP	
Manufacturer ID	11 _h
Ident number	1521 _h
Profile version	2.0
GSD files	www.products.endress.com/profibus
GSD file version	
Output values	Main value, temperature value
Input values	Display value of PLC
Features supported	Device locking: The device can be locked by hardware or software.

Power supply

Electrical connection

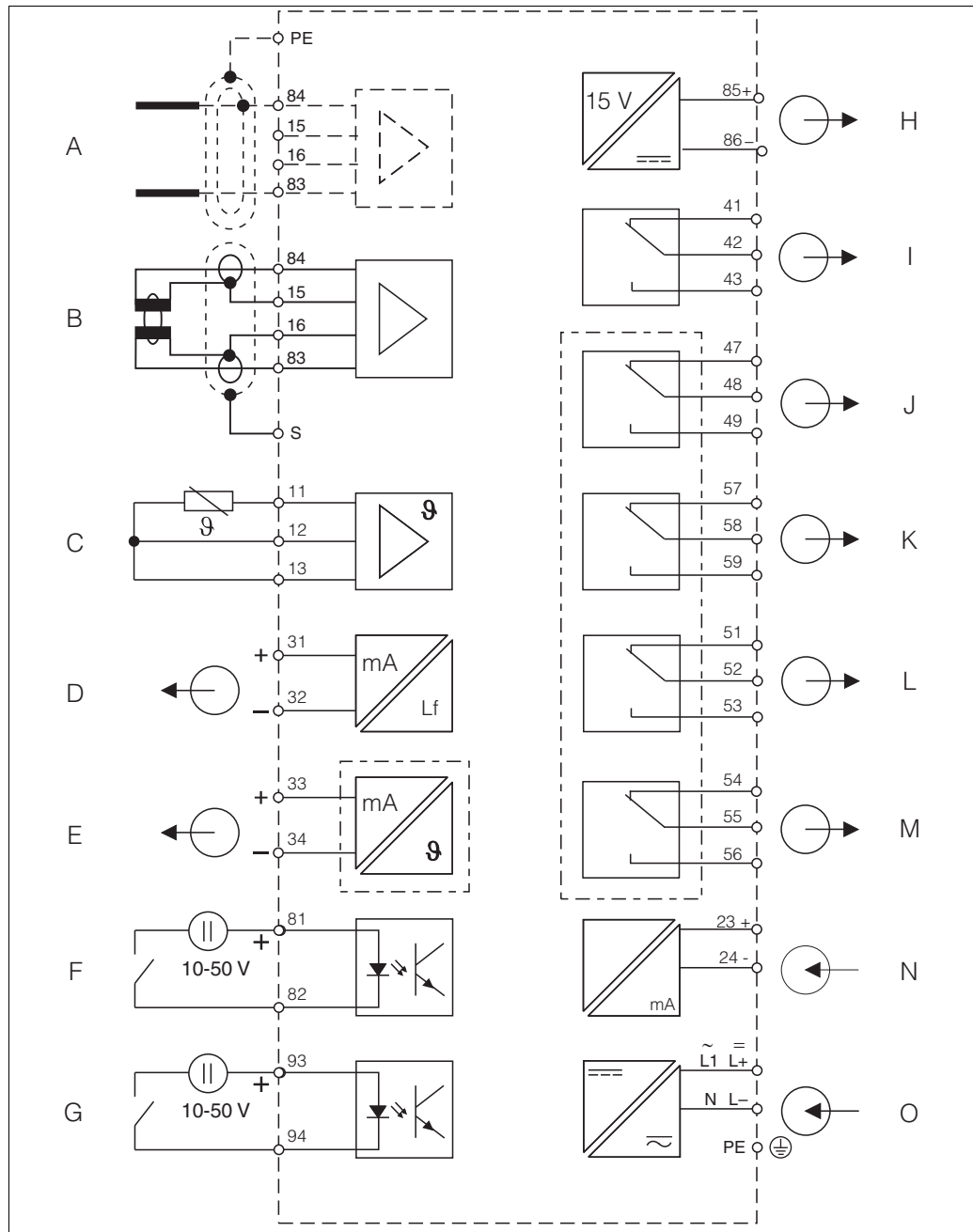

C07-CLM2x3xx-04-06-00-xx-001.eps

Electrical connection of the transmitter

- A Sensor (conductive)
- B Sensor (inductive)
- C Temperature sensor
- D Signal output 1 conductivity
- E Signal output 2 variable
- F Binary input 1 (Hold)
- G Binary input 2 (Chemoclean)
- H Aux. voltage output

- I Alarm (current-free contact position)
- J Relay 1 (current-free contact position)
- K Relay 2 (current-free contact position)
- L Relay 3 (current-free contact position)
- M Relay 4 (current-free contact position)
- N Current input 4 ... 20 mA
- O Power supply

The instrument has protection class II and is generally operated without protective earth connection. To ensure the measuring stability and the function for conductive sensors you have to connect the outer screen of the sensor cable to the PE terminal.

Connection of sensor

You require screened special measuring cables to connect conductivity sensors to the transmitter. To extend the measuring cable, use junction box and extension cable (see accessories).

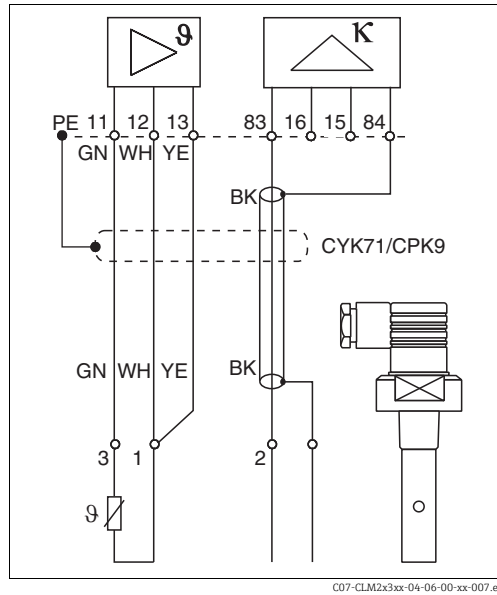

C07-CLM2x3-xx-04-06-00-xx-007.eps

Connection of conductive sensors

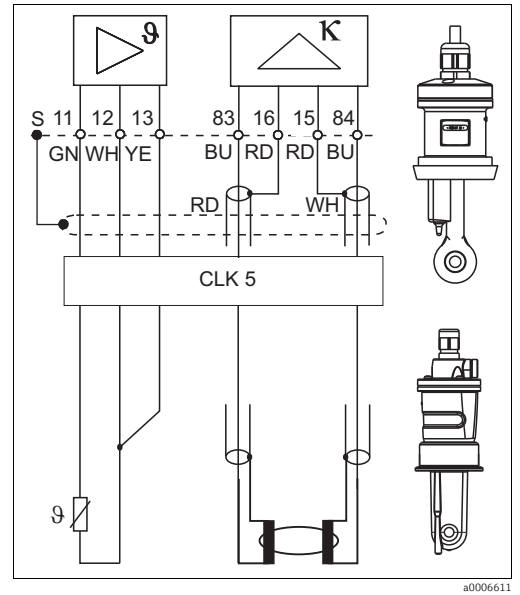

a0006611

Connection of inductive sensors

Supply voltage

Depending on ordered version:
 100/115/230 V AC +10/-15 %, 48 to 62 Hz
 24 V AC/DC +20/-15 %

Fieldbus connection

HART	
Supply voltage	n/a, active current outputs
Integrated reverse voltage protection	n/a, active current outputs

PROFIBUS PA	
Supply voltage	9 V to 32 V, max. 35 V
Polarity sensitive	no
FISCO/FNICO compliant acc. to IEC 60079-27	no

PROFIBUS DP	
Supply voltage	9 V to 32 V, max. 35 V
Polarity sensitive	n/a
FISCO/FNICO compliant acc. to IEC 60079-27	no

Power consumption

max. 7.5 VA

Mains protection

Fine-wire fuse, medium-slow blow 250 V/3.15 A

Circuit breaker

NOTICE

The device does not have a power switch

- ▶ You must provide a protected circuit breaker in the vicinity of the device.
- ▶ This must be a switch or a power-circuit breaker and you must label it as the circuit breaker for the device.
- ▶ At the supply point, the power supply for the 24 V versions must be isolated from dangerous live cables by double or reinforced insulation.

Performance characteristics

Reference temperature	25 °C (77 °F); adjustable for the compensation of the medium temperature	
Resolution	Conductivity:	depending on the measuring range: 0.001 µS/cm to 1.999 µS/cm and $k \leq 0.5 \text{ cm}^{-1}$
	Temperature:	0.1 °C
Maximum measured error¹⁾	Conductivity:	
	Display:	max. 0.5 % of measured value ± 4 digits
	Conductivity signal output:	max. 0.75 % of current output range
	Resistivity:	
	Display:	max. 0.5 % of measured value ± 4 digits
	Resistivity signal output:	max. 0.75 % of current output range
	Temperature:	
	Display:	max. 1.0 % of measuring range
	Temperature signal output:	max. 1.25 % of current output range
Repeatability¹⁾	Conductivity:	max. 0.2 % of measured value ± 2 digits
	Resistivity:	max. 0.2 % of measured value ± 2 digits
Temperature compensation	Range:	-35 to +250 °C (-31 to +482 °F)
	Types of compensation:	uncompensated, linear, NaCl, table; conductive only: ultrapure water NaCl, ultrapure water HCl
Temperature offset	±5 °C; for the adjustment of the temperature display	

1) acc. to IEC 746-1, for nominal operating conditions

Installation

Installation instructions

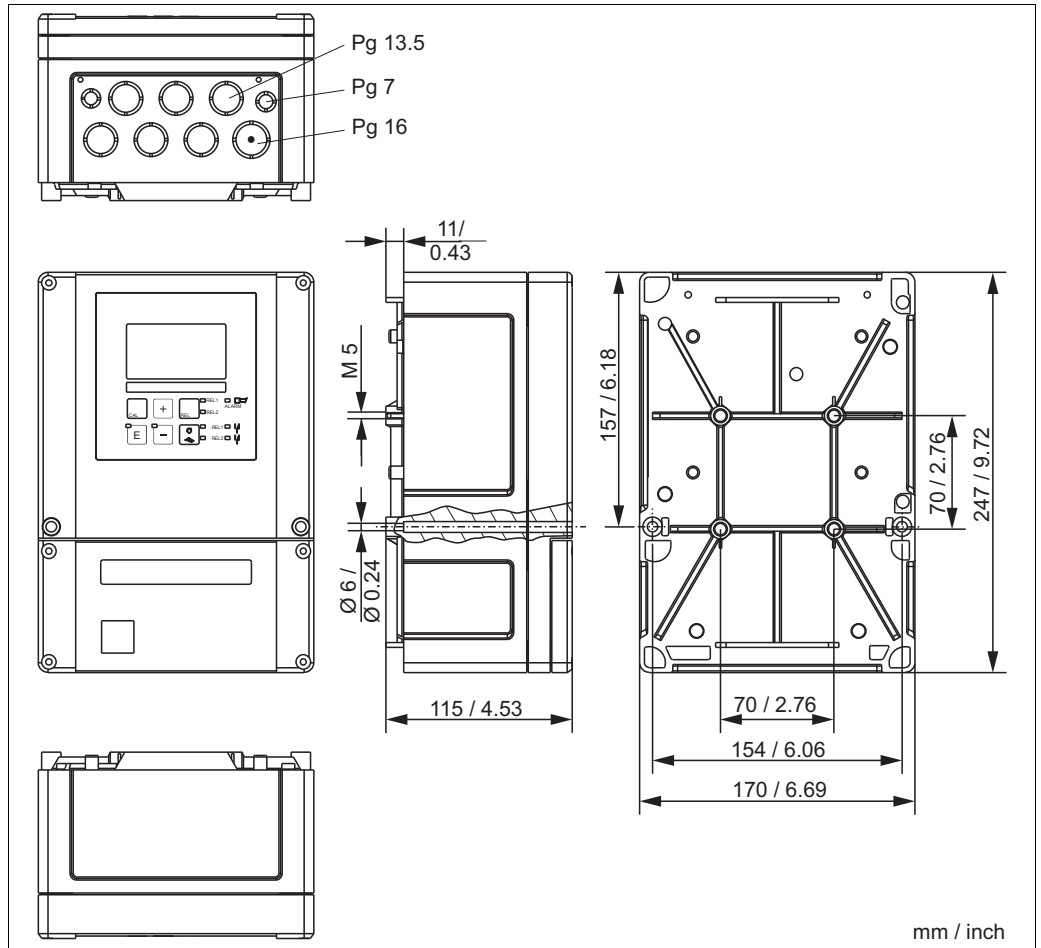

a0005733

Field instrument

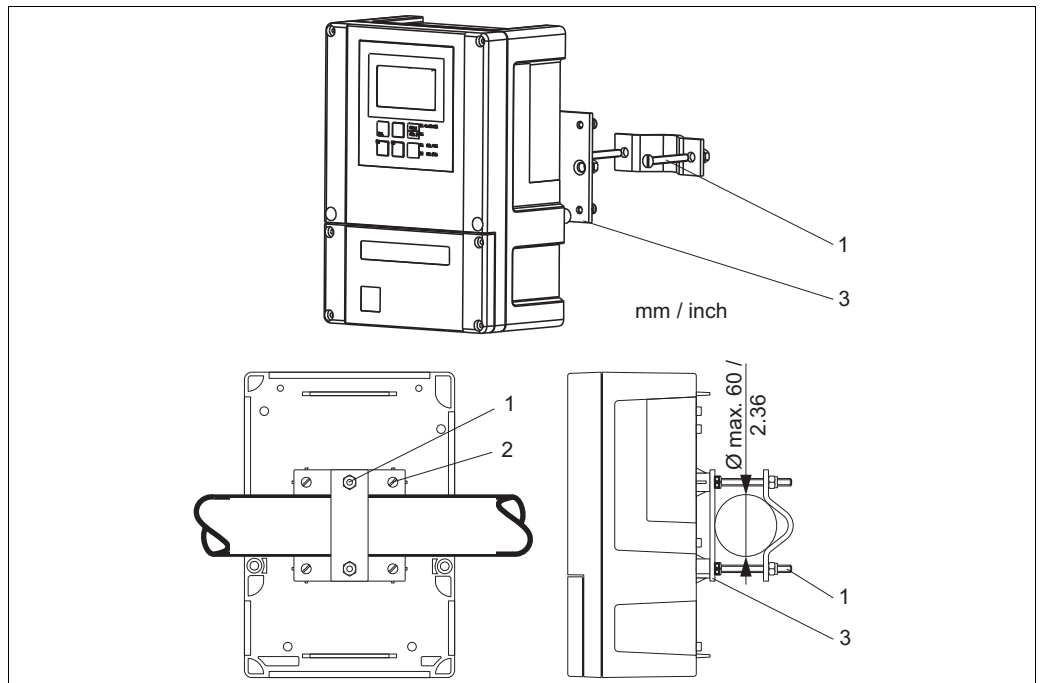

a0005737

Mounting on pipes

1 - 3 Mounting screws and mounting plate

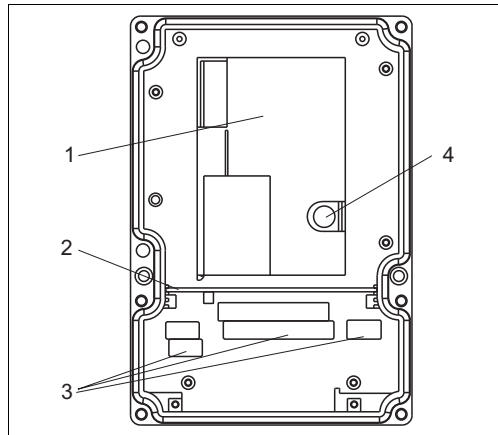

- 1 Removable electronics box
- 2 Partition plate
- 3 Terminal blocks
- 4 Fuse

a0005734

View into the field instrument

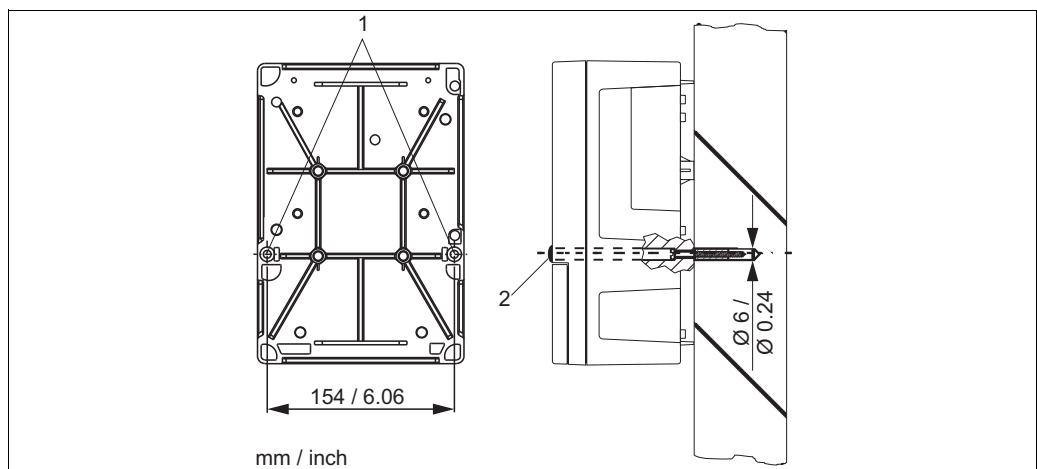

a0005736

Wall mounting of the field instrument

- 1 Mounting holes
- 2 Protecting cap

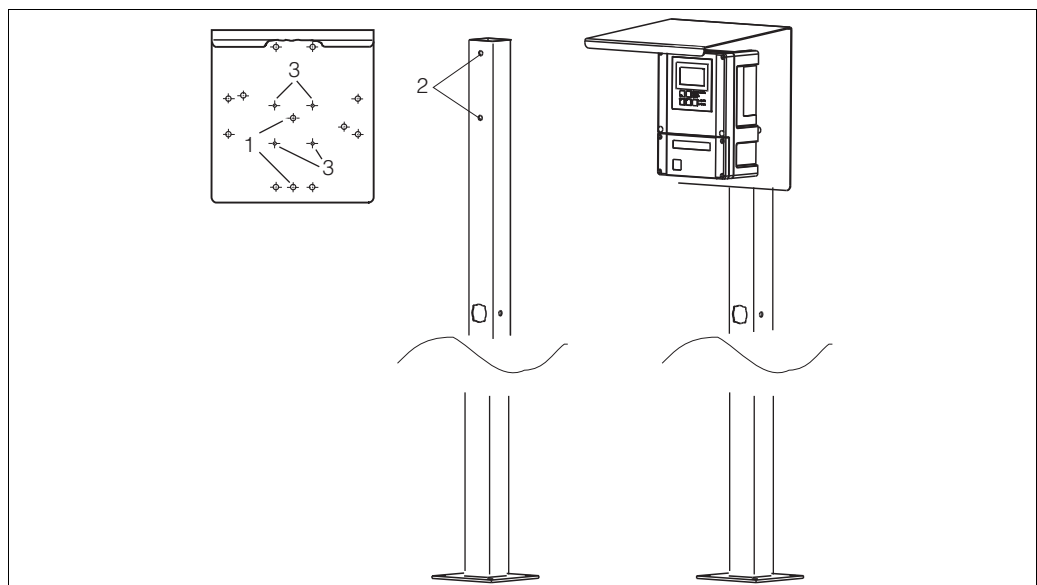

a0005738

Mounting of the field instrument with mounting post and weather protection cover

- 1 - 3 Mounting holes

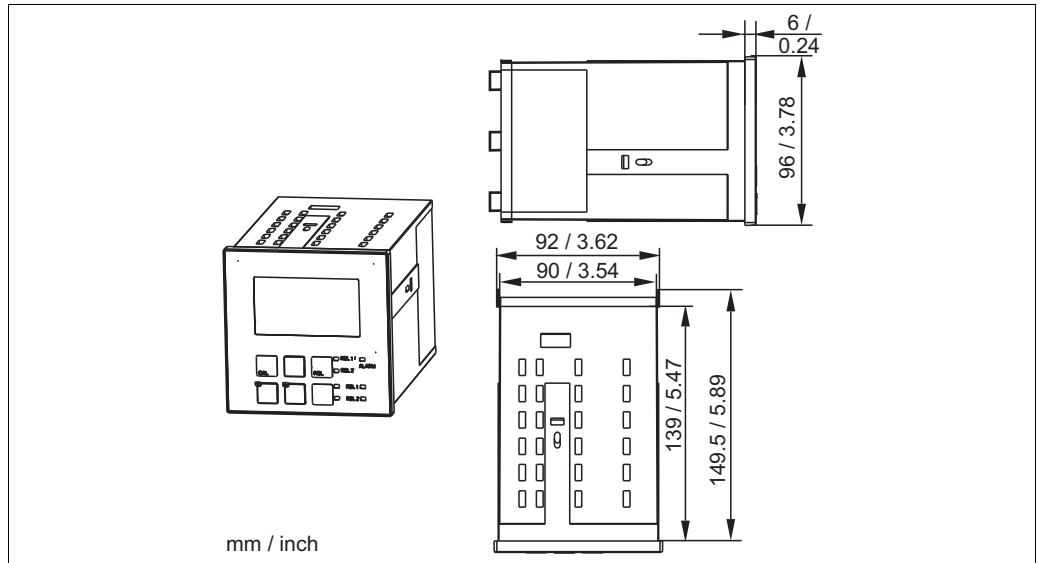

a0005735

Dimensions panel-mounted instrument

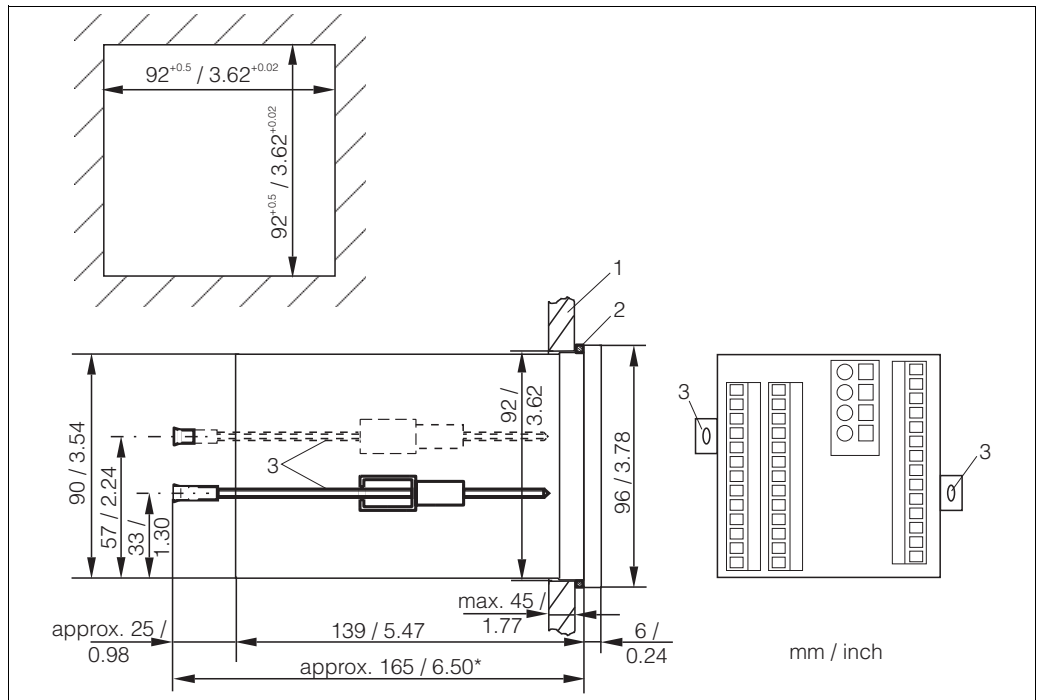

a0005739

Installation of the panel-mounted instrument

- 1 Wall of control cabinet
- 2 Gasket
- 3 Tensioning screws
- * Required installation depth

Environment

Ambient temperature	-10 to +55 °C (+14 to +131 °F)	
Storage temperature	-25 to +65 °C (-13 to +149 °F)	
Electromagnetic compatibility	Interference emission and interference immunity as per EN 61326-1:2006, EN 61326-2-3:2006	
Ingress protection	Panel mounted instrument: Field instrument:	IP 54 (front), IP 30 (housing) IP 65 / tightness acc. to NEMA 4X
Electrical safety	according EN/IEC 61010-1:2001, Installation Category II, for use up to 2000 m above sea level	
CSA	Apparatus with CSA General Purpose Approval are certified for indoor use.	
Relative humidity	10 to 95%, non-condensing	
Pollution degree	The product is suitable for pollution degree 2.	

Mechanical construction

Dimensions	Panel mounted instrument: Field instrument:	96 x 96 x 145 mm (3.78 x 3.78 x 5.71 inches) Installation depth: approx. 165 mm (6.50") 247 x 170 x 115 mm (9.72 x 6.69 x 4.53 inches)
Weight	Panel mounted instrument: Field instrument:	max. 0.7 kg (1.5 lb) max. 2.3 kg (5.1 lb)
Material	Housing of panel mounted instrument: Field housing: Front membrane:	Polycarbonate ABS PC Fr Polyester, UV-resistant
Terminals	Cross section	max. 2.5 mm ²

Operability

Operating concept

All instrument control functions are arranged in a logical menu structure. Following access code entry, the individual parameters can be easily selected and modified as needed.

Display elements

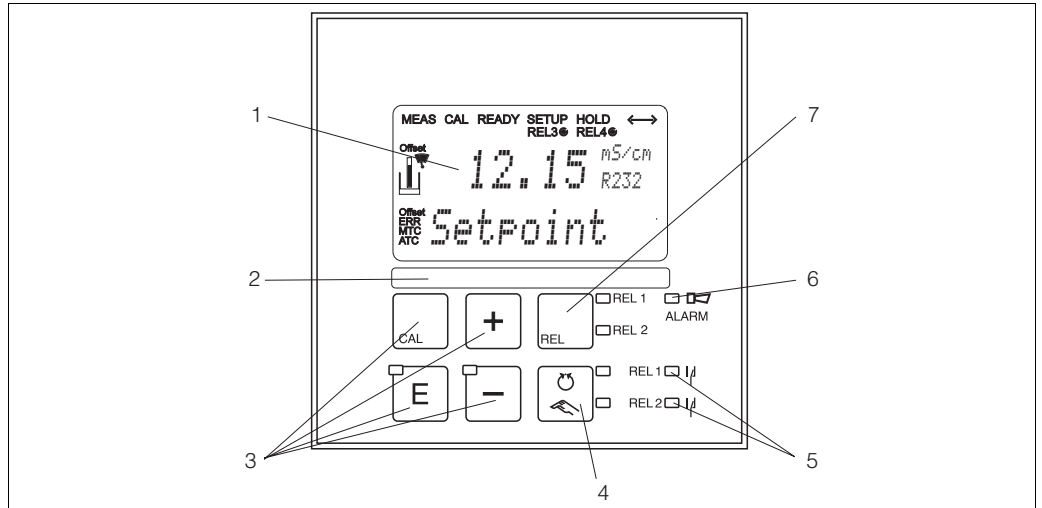

C07-CLM2x3xx-19-06-00-en-001.eps

Operating elements

- 1 LC display for display of measured values, configuration data and current menu field
- 2 Field for user labelling
- 3 4 main control keys for calibration and instrument configuration
- 4 Key for switching between automatic/manual operation of the relays
- 5 LED indicators for limit contactor relay (switch status)
- 6 LED indicator for alarm function
- 7 Display of active contact and key for relay switching in manual mode

The display simultaneously shows the current measured value and the temperature - the essential process data. Brief information texts in the configuration menu provide assistance with parameter configuration.

Certificates and approvals

CE symbol

Declaration of conformity

The product meets the requirements of the harmonized European standards. It thus complies with the legal requirements of the EC directives.

The manufacturer confirms successful testing of the product by affixing the CE symbol.

CSA General Purpose

CSA General Purpose

The products listed below are eligible to bear the CSA Mark shown with adjacent indicators "C" and "US":

Version	Approval
CLM253-..2... CLM253-..3... CLM253-..7...	CSA Mark for Canada and USA
CLM223-..2... CLM223-..3... CLM223-..7...	CSA Mark for Canada and USA

Ordering information

Order code

Enter the following address into your browser to access the relevant product page:
www.products.endress.com/clm223 or
www.products.endress.com/clm253

1. You can choose from the following options on the product page located on the right:

Product page function
:: Add to product list
:: Price & order information
:: Compare this product
:: Configure this product

2. Click "Configure this product".
3. The configurator opens in a separate window. You can now configure your device and receive the complete order code that applies for the device.
4. Afterwards, export the order code as a PDF or Excel file. To do so, click the appropriate button at the top of the page.

Product structure

Input, software	
CD	Conductivity/resistivity measurement (conductive two-electrode sensor)
CS	Conductivity/resistivity measurement (conductive two-electrode sensor) with additional functions (Plus package)
ID	Conductivity measurement (inductive sensor)
IS	Conductivity measurement (inductive sensor) with additional functions (Plus package)
Power supply, approval	
0	230 V AC
1	115 V AC
2	230 V AC; CSA Gen. Purp.
3	115 V AC; CSA Gen. Purp.
5	100 V AC
7	24 V AC/DC; CSA Gen. Purp.
8	24 V AC/DC
Output	
0	1 x 20 mA, primary value
1	2 x 20 mA, primary value + secondary value
3	PROFIBUS PA
4	PROFIBUS DP
5	1 x 20 mA, primary value, HART
6	2 x 20 mA, primary value, HART + secondary value
Additional contacts	
05	not selected
10	2 relays (limit/P(ID)/timer)
15	4 relays (limit/P(ID)/Chemoclean) (not with PROFIBUS DP)
16	4 relays (limit/P(ID)/timer) (not with PROFIBUS DP)
20	1 x 4 ... 20 mA input + 2 relays (limit/P(ID)/timer)
25	1 x 4 ... 20 mA input + 4 relays (limit/P(ID)/Chemoclean) (not with PROFIBUS DP)
26	1 x 4 ... 20 mA input + 4 relays (limit/P(ID)/timer) (not with PROFIBUS DP)
Additional features (CLM223 only)	
PRL	Protective layer
Marking	
1	Tagging (Tag), see additional spec.
CLM253-	
CLM223-	

complete order code

Additional functions of the Plus package

- Current output table to cover large ranges with varying resolution, fields O33x
 - Process Check System (PCS): live check of the sensor, function group P
 - Ultrapure water monitoring for "Water for injection" (WFI) and "Purified water" (PW) acc. to United States Pharmacopeia (USP) and European Pharmacopoeia (EP) with pre-alarm (conductive, additional contacts necessary), fields R26x and R27x
 - Polarization detection (conductive), function group P
 - Concentration measurement, function group K
 - Temperature compensation via coefficient table, function group T
 - Adaptive calibration with installation factor (inductive), fields C13x
 - Automatic cleaning function start, field F8
-

Scope of delivery

The delivery of the field instrument includes:

- 1 transmitter CLM253
- 1 plug-in screw terminal
- 1 cable gland Pg 7
- 1 cable gland Pg 16 reduced
- 2 cable glands Pg 13.5
- 1 Operating Instructions BA00193C/07/EN
- 1 Operating Instructions
 - versions with HART communication:
 - 1 Operating Instructions Field Communication with HART, BA00208C/07/EN
 - versions with PROFIBUS communication:
 - 1 Operating Instructions Field Communication with PROFIBUS PA/DP, BA00209C/07/EN

The delivery of the panel mounted instrument includes:

- 1 transmitter CLM223
- 1 set of plug-in screw terminals
- 2 tensioning screws
- 1 Operating Instructions BA00193C/07/EN
- 1 Operating Instructions
 - versions with HART communication:
 - 1 Operating Instructions Field Communication with HART, BA00208C/07/EN
 - versions with PROFIBUS communication:
 - 1 Operating Instructions Field Communication with PROFIBUS PA/DP, BA00209C/07/EN

Accessories

Sensors

Condumax W CLS12

- Conductive conductivity sensor for standard, Ex and high-temperature applications;
- Ordering acc. to product structure, www.products.endress.com/cls12
- Technical Information TI00082C/07/EN

Condumax W CLS13

- Conductive conductivity sensor for standard, Ex and high-temperature applications;
- Ordering acc. to product structure, www.products.endress.com/cls13
- Technical Information TI00083C/07/EN

Condumax W CLS15

- Conductive conductivity sensor for pure and ultra-pure water applications (incl. Ex);
- Ordering acc. to product structure, www.products.endress.com/cls15
- Technical Information TI00109C/07/EN

Condumax H CLS16

- Hygienic conductive conductivity sensor for pure and ultra-pure water applications (incl. Ex);
- Ordering acc. to product structure, www.products.endress.com/cls16
- Technical Information TI00227C/07/EN

Condumax W CLS19

- Conductive conductivity sensor for pure and ultra-pure water applications;
- Ordering acc. to product structure, www.products.endress.com/cls19
- Technical Information TI00110C/07/EN

Condumax W CLS21

- Conductive conductivity sensor for applications with middle to high conductivity (incl. Ex);
- Ordering acc. to product structure, www.products.endress.com/cls21
- Technical Information TI00085C/07/EN

Indumax P CLS50

- Inductive conductivity sensor for standard, Ex and high-temperature applications
- Ordering acc. to product structure, www.products.endress.com/cls50
- Technical Information TI00118C/07/EN

Indumax H CLS52

- Inductive conductivity sensor with short response time for food applications
- Ordering acc. to product structure, www.products.endress.com/cls52
- Technical Information TI00167C/07/EN

Indumax H CLS54

- Inductive conductivity sensor for standard, Ex and in hygienic design for applications in food, beverages, pharmaceuticals and biotechnology
- Ordering acc. to product structure, www.products.endress.com/cls54
- Technical Information TI00400C/07/EN

Connection accessories**CYK71 measuring cable**

- Non-terminated cable for the connection of sensors (e.g. conductivity sensors) or the extension of sensor cables
- Sold by the meter, order numbers:
 - non-Ex version, black: 50085333
 - Ex version, blue: 50085673

Extension cable CLK6

- For inductive conductivity sensors, for extension via the VBM junction box, sold by the meter
- Order no.: 71183688

Junction box VBM

- For cable extension
- 10 terminals
- Cable entries: 2 x Pg 13.5 or 2 x NPT ½"
- Material: aluminum
- Ingress protection: IP 65 (≅ NEMA 4X)
- Order numbers:
 - cable entries Pg 13.5: 50003987
 - cable entries NPT ½": 51500177
- Four-pole metal plug M12 for fieldbus connection
order no. 51502184

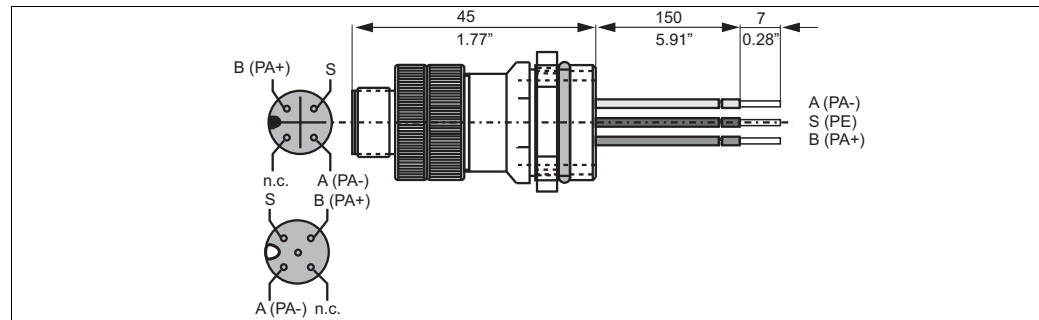

C07-CM12xxx-02-06-00-xxx-002.eps

M12 plug with socket

Mounting accessories**CYY101 weather protection cover for field devices, absolutely essential if operating the unit outdoors**

- Material: stainless steel 1.4031 (AISI 304)
- Order No. CYY101-A

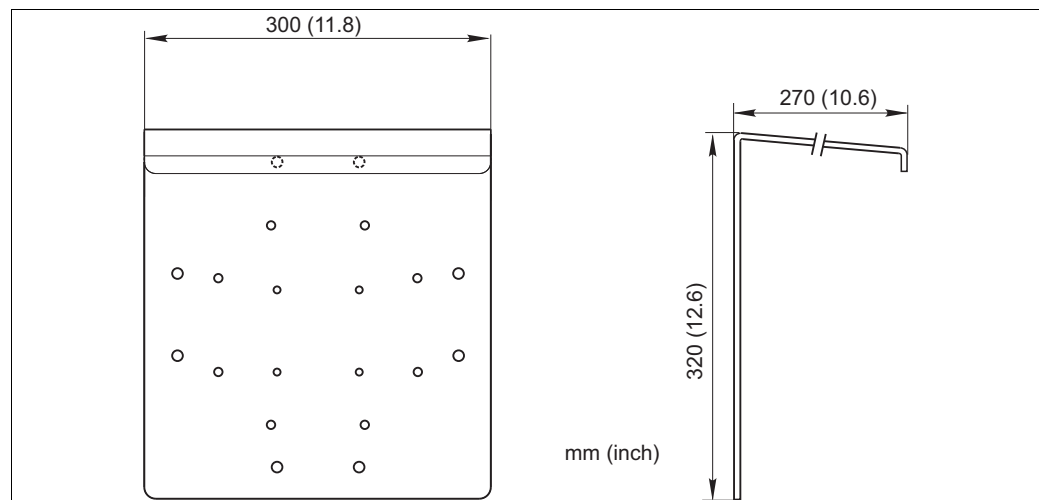

a0019166

Weather protection cover for field devices

Post mounting kit

- For mounting of field housing on horizontal or vertical pipes (\varnothing max. 60 mm (2.36"))
- Material: stainless steel 1.4301
- order no. 50086842

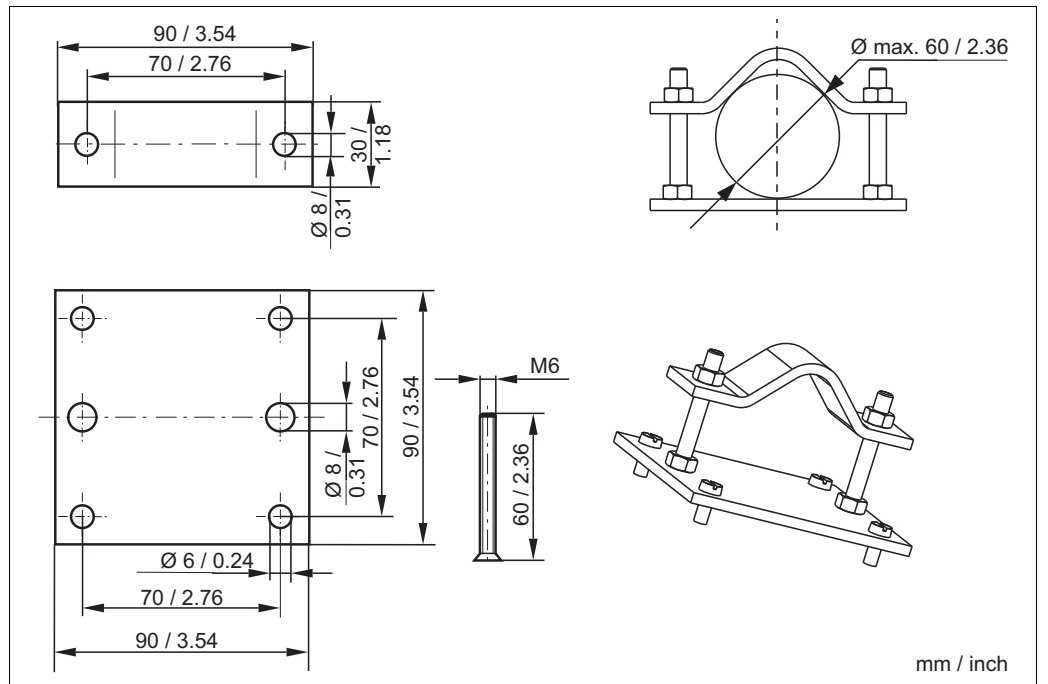

Post mounting kit

CYY102 universal post

- Square pipe for mounting transmitters
- Material: stainless steel 1.4301 (AISI 304)
- Order No. CYY102-A

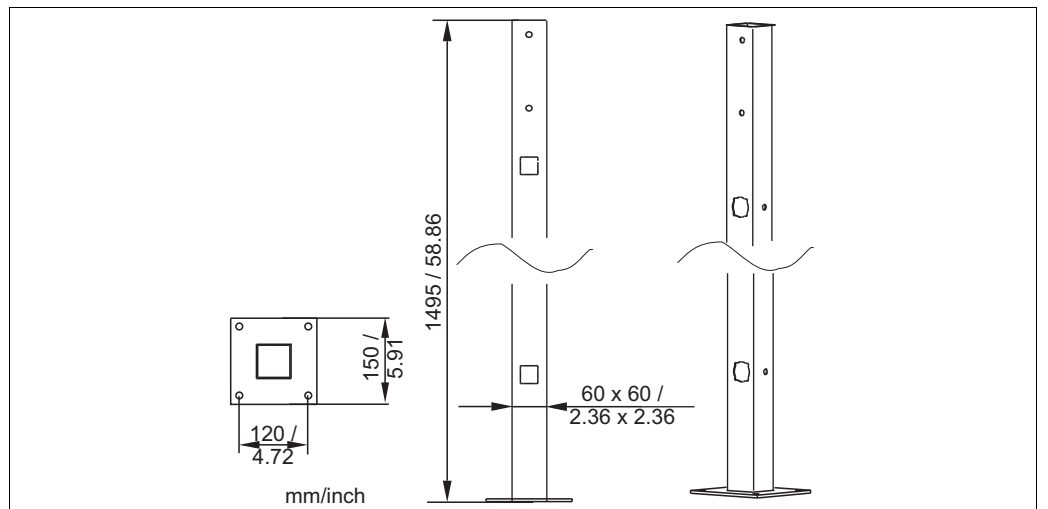

Universal post

Buffer solutions

Precision calibration solutions, acc. to SRM (Standard reference material) of NIST, reference temperature 25 °C (77 °F), with temperature table

- CLY11-A, 74.0 $\mu\text{S}/\text{cm}$, 500 ml (16.9 fl.oz); order no. 50081902
- CLY11-B, 149.6 $\mu\text{S}/\text{cm}$, 500 ml (16.9 fl.oz); order no. 50081903
- CLY11-C, 1.406 mS/cm , 500 ml (16.9 fl.oz); order no. 50081904
- CLY11-D, 12.64 mS/cm , 500 ml (16.9 fl.oz); order no. 50081905
- CLY11-E, 107.0 mS/cm , 500 ml (16.9 fl.oz); order no. 50081906

www.addresses.endress.com
