

Technical Information

Thermowell

Omnigrad M TW15

Heavy duty - General purpose
Weld-in or flanged process connection



Application

TW15 is designed for use with resistance and thermocouple thermometers in heavy duty applications.

Modular configuration according to DIN 43772 (form 4/4F) enable a use in all industrial processes with severe thermal and mechanical stresses.

Your benefits

- TW15 is a barstock thermowell.
- The process connection can either be weld-in or flanged.
- Extension, immersion length and total length can be chosen according to process requirements.
- A wide choice of dimensions, materials and process connections is available.
- Special versions can be manufactured according to customer requirements.

Function and system design

Equipment architecture

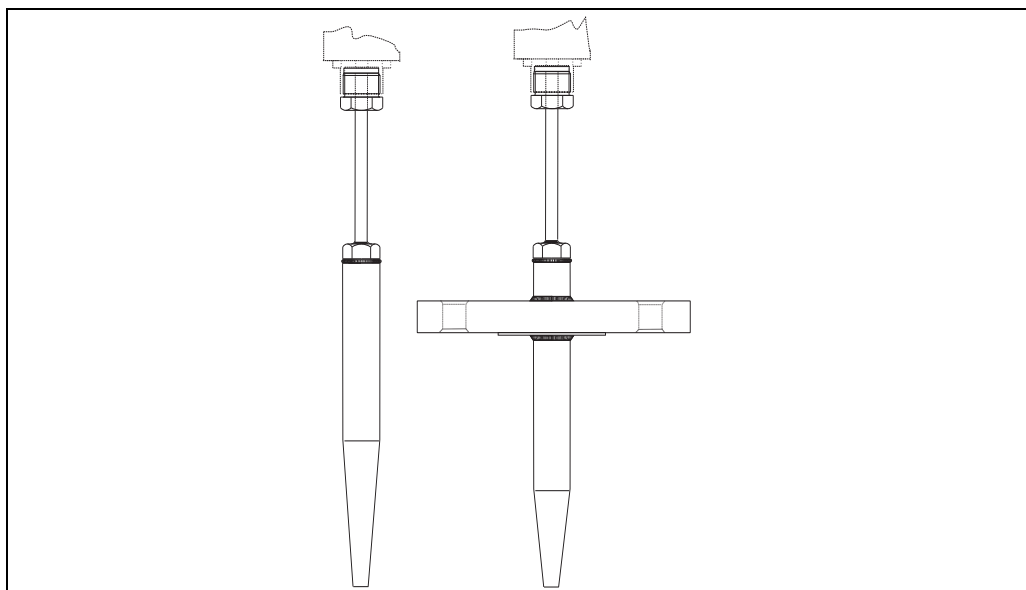

A0017835

Equipment architecture of the Omnigrad M TW15

The Omnigrad M TW15 thermowells are designed according to DIN 43772 and can therefore guarantee a good level of resistance to the most typical and common industrial processes. The thermowell is made from a metal bar with a diameter of 18, 24 or 26 mm (0.71, 0.94 or 1.02 in). The end of the thermowell is conical with a tip diameter of 9 or 12.5 mm (0.35 or 0.49 in). As process connection the TW15 offers weld-in or different flanged versions.

Performance characteristics

Operating conditions

Process pressure (static)

Process connection	Standard	Max. process pressure
Weld-in version	-	≤ 400 bar (5800 psi)
Flange	EN1092-1 or ISO 7005-1	20, 40 or 50 bar depending on the flange pressure rating PNxx
	ANSI B16.5	Depending on the flange pressure rating 150 or 300 psi
	JIS B 2220	Depending on the flange pressure rating 20K, 25K or 40K

Permitted flow velocity depending on the immersion length

The highest flow velocity tolerated by the thermometer diminishes with increasing immersion length exposed to the stream of the fluid. In addition it is dependent on the geometry of the thermometer, the process medium, the process temperature and the process pressure. The following figures exemplify the maximum permitted flow velocities in water and superheated steam at a process pressure of 5 MPa (50 bar = 725 PSI).

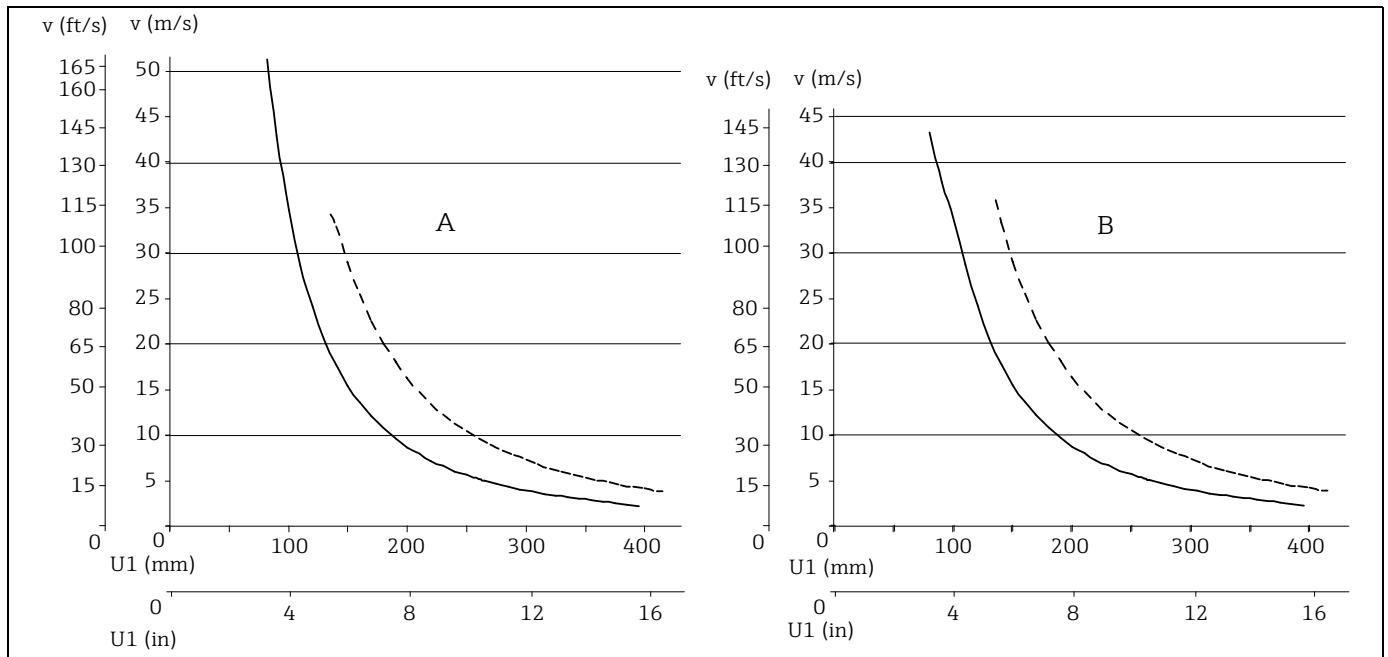

Thermowell with D = 18 mm (0.71 in), U = 65 mm (2.56 in) -----
 Thermowell with D = 24 mm (0.94 in), U = 125 mm (4.9 in) -----

- A Medium water at T = 50 °C (122 °F)
- B Medium superheated steam at T = 400 °C (752 °F)
- U1 Immersion length thermowell, material 1.4571 (316Ti)
- v Flow velocity

Material

Thermowell and process connections.

The temperatures for continuous operation specified in the following table are only intended as reference values for use of the various materials in air and without any significant compressive load. The maximum operation temperatures are reduced considerably in some cases where abnormal conditions such as high mechanical load occur or in aggressive media.

Material name	Short form	Recommended max. temperature for continuous use in air	Properties
AISI 316Ti/ 1.4571	X6CrNiMoTi17-12-2	700 °C (1292 °F) ¹⁾	<ul style="list-style-type: none"> ▪ Austenitic, stainless steel ▪ High corrosion resistance in general ▪ Particularly high corrosion resistance in chlorine-based and acidic, non-oxidizing atmospheres through the addition of molybdenum (e.g. phosphoric and sulfuric acids, acetic and tartaric acids with a low concentration) ▪ Addition of titanium means increased resistance to intergranular corrosion even after welding ▪ Broad range of uses in the chemical, petrochemical and oil industries as well as in coal chemistry ▪ Can only be polished to a limited extent, titanium streaks can form
Hastelloy® C276/ 2.4819	NiMo 16 Cr 15 W	1100 °C (2012 °F)	<ul style="list-style-type: none"> ▪ A nickel-based alloy with good resistance to oxidizing and reducing atmospheres, even at high temperatures ▪ Particularly resistant to chlorine gas and chloride as well as to many oxidizing mineral and organic acids
AISI A182 F11/1.7335	13CrMo4-5	550 °C (1022 °F)	<ul style="list-style-type: none"> ▪ Low alloy, heat-resistant steel with chromium and molybdenum additions ▪ Better corrosion resistance compared to non-alloy steels, not suitable for acids and other aggressive media ▪ Often used in steam generators, water and steam pipes, pressure vessels
Titanium/ 3.7035	-	600 °C (1112 °F)	<ul style="list-style-type: none"> ▪ A light metal with very high corrosion resistance and strength values ▪ Very good resistance to many oxidizing mineral and organic acids, saline solutions, sea water etc. ▪ Prone to fast embrittlement at high temperatures through the absorption of oxygen, nitrogen and hydrogen ▪ Compared to other metals, titanium reacts readily with many media (O₂, N₂, Cl₂, H₂) at higher temperatures and/or increased pressure ▪ Can only be used in chlorine gas and chlorinated media at comparatively low temperatures (<400 °C)
Duplex SAF2205/ 1.4462	X2CrNiMoN22-5-3	300 °C (572 °F)	<ul style="list-style-type: none"> ▪ Austenitic ferritic steel with good mechanical properties ▪ High resistance to general corrosion, pitting, chlorine-induced or transgranular stress corrosion ▪ Comparatively good resistance to hydrogen-induced stress corrosion
1.5415	16Mo3	530 °C (986 °F)	<ul style="list-style-type: none"> ▪ Alloyed creep-resistant steel ▪ Particularly well suited as pipe material for boiler construction, super heater tube, superheated steam and collecting pipe, stove and line pipes, for heat exchangers and for the purposes of oil-refining industries
1.7380	10CrMo910	580 °C (1076 °F)	<ul style="list-style-type: none"> ▪ Alloyed creep-resistant steel ▪ Particularly well suited for steam boilers, boiler parts, boiler drums, pressure vessels for apparatus construction and similar purposes
AISI A105/ 1.0460	C22.8	450 °C (842 °F)	<ul style="list-style-type: none"> ▪ Heat-resistant steel ▪ Resistant in nitrogen-containing atmospheres and atmospheres that are low in oxygen; not suitable for acids or other aggressive media ▪ Often used in steam generators, water and steam pipes, pressure vessels

1) Can be used to a limited extent up to 800 °C (1472 °F) for low compressive loads and in non-corrosive media. Please contact your Endress+Hauser sales team for further information.

Components

Design, dimensions

All dimensions in mm (in).

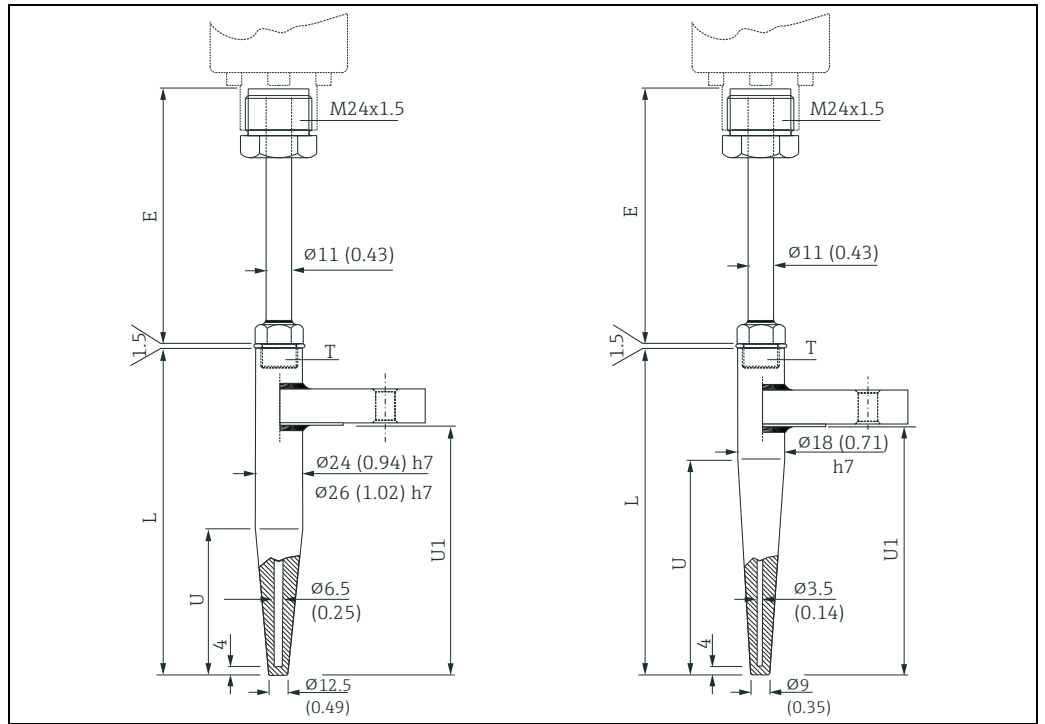

A0018321

Dimensions of the Omnigrad M TW15

- | | | | |
|----|--|---|---|
| E | Neck tube length | T | Thread neck tube connection to thermowell |
| U | Length of conical tip | L | Immersion length |
| U1 | Immersion length; length of the part of the thermowell in contact with the process from the tip to the sealing surface of the flange | | |



The thermowell with $\varnothing 18$ mm (0.71 in) with a total length L of more than 200 mm (7.87 in) will be produced with a stepped bore $\varnothing 6.5$ reduced to $\varnothing 3.5 \times 35$ mm.

The surface roughness Ra is 0.8 μm or 1.6 μm depending on the selected option.

Weight

From 0.5 to 5.0 kg (1 to 11 lbs) for standard options.

Process connection

Standard connections are available as weld-in connection (without flange) or with flange. The following figure shows the basic dimensions of the available flanges.

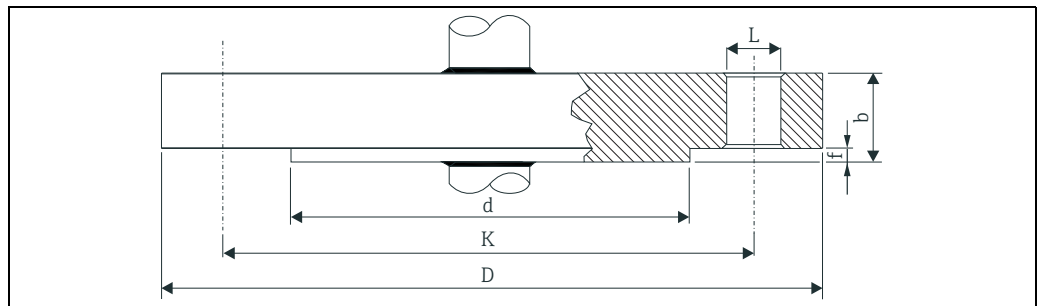

A0010471

Basic dimensions of the flange process connections

For detailed information on the flange dimensions refer to the following flange standards:

- ANSI/ASME B16.5
- ISO 7005-1
- EN 1092-1
- JIS B 2220 : 2004
- DIN 2526/7

The flange material should be the same as of the stem of the thermowell. Models in Hastelloy® C have flanges in basic material SS 316L and a disc in Hastelloy® C on the surface in contact with the process media.

Installation conditions

Orientation

No restrictions.

Installation instructions

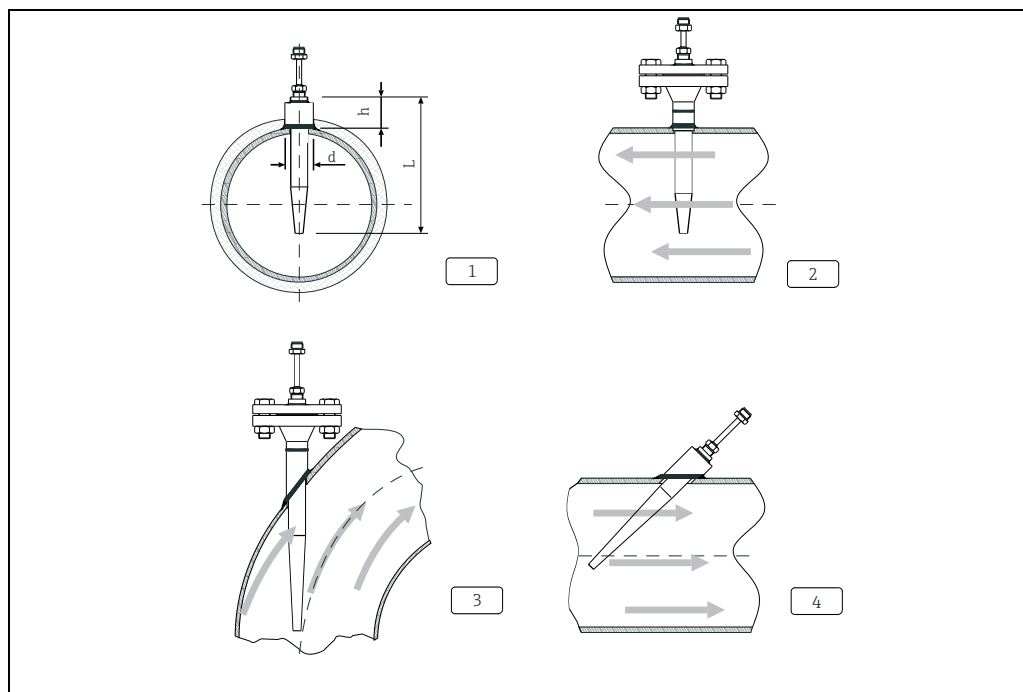

A0017856

Installation examples

1 - 2: In pipes with a small cross section the sensor tip should reach or extend slightly past the center line of the pipe ($= L$)
 3 - 4: Tilted installation

The immersion length of the thermometer influences the accuracy. If the immersion length is too small then errors in the measurement are caused by heat conduction via the process connection and the container wall. If installing into a pipe then the immersion length should be half of the pipe diameter, if possible (see 1 and 2). A further solution could be an angled (tilted) installation (see 3 and 4). When determining the immersion length all thermometer parameters and the process to be measured must be taken into account (e.g. flow velocity, process pressure).

- Installation possibilities: Pipes, tanks or other plant components
- Recommended minimum immersion length = 150 mm (5.91 in)
 The immersion length should correspond to at least 8 times of the thermowell diameter.
 Example: Thermowell diameter 24 mm (0.94 in) x 8 = 192 mm (7.56 in).

Neck tube length

The neck tube is the part between the process connection and the housing. It is normally made of a tube with dimensional and physical characteristics (diameter and material) which are the same as of the tube in contact with the medium.

The connection situated in the upper part of the neck allows for orientation of the terminal head. As illustrated in the following figure, the neck tube length may influence the temperature in the terminal head. It is necessary that this temperature is kept within the limit values defined in the chapter "Operating conditions" of the corresponding transmitter.

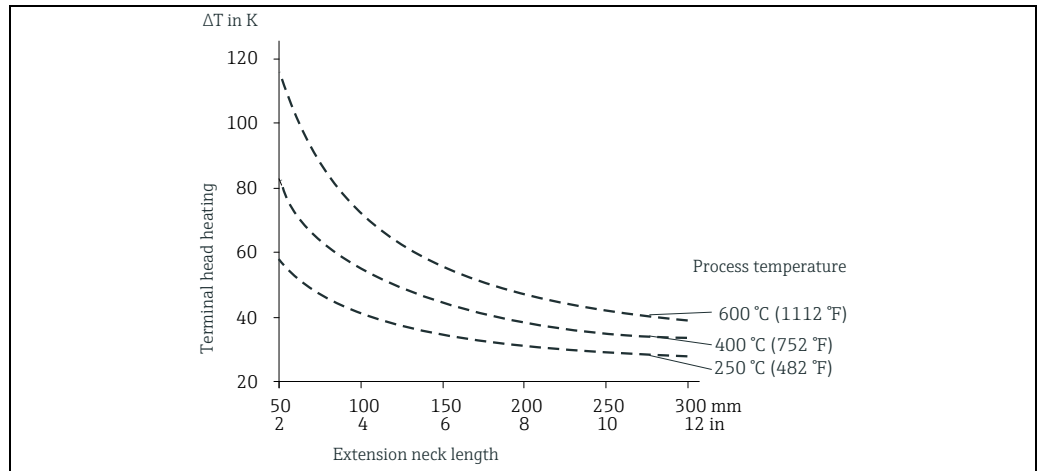

Heating of the terminal head consequent to the process temperature.
 Temperature in terminal head = ambient temperature 20 °C (68 °F) + ΔT

Certificates and approvals

CE mark

The device meets the legal requirements of the EC directives if applicable. Endress+Hauser confirms that the device has been successfully tested by applying the CE mark.

PED approval

The thermowell complies with paragraph 3.3 of the Pressure Equipment Directive (97/23/CE) and is not marked separately.

Material certification

The material certificate 3.1 (according to standard EN 10204) can be directly selected from the sales structure of the product and refers to the parts of the sensor in contact with the process fluid. Other types of certificates related to materials can be requested separately. The "short form" certificate includes a simplified declaration with no enclosures of documents related to the materials used in the construction of the single sensor and guarantees the traceability of the materials through the identification number of the thermometer. The data related to the origin of the materials can subsequently be requested by the client if necessary.

Test on thermowell

Thermowell pressure tests are carried out in accordance with the specifications in the DIN 43772 standard. With regards to thermowells with tapered or reduced tips that do not comply with this standard these are tested using the pressure of corresponding straight thermowells. Sensors certified for use in Ex Zones, are always tested to pressures according to the same criteria. Tests according to other specifications can be carried out on request. Dye penetration tests verify the absence of cracks on the thermowell welding.

Ordering information

Detailed ordering information is available from the following sources:

- In the **Product Configurator** on the Endress+Hauser website:
www.endress.com → Select country → Instruments → Select device → Product page function:
Configure this product
- From your Endress+Hauser Sales Center:
www.endress.com/worldwide



Product Configurator - the tool for individual product configuration:

- Up-to-the-minute configuration data
- Depending on the device: Direct input of measuring point-specific information such as measuring range or operating language
- Automatic verification of exclusion criteria
- Automatic creation of the order code and its breakdown in PDF or Excel output format
- Ability to order directly in the Endress+Hauser Online Shop

www.addresses.endress.com
