



Level



Pressure



Flow



Temperature

Liquid
Analysis

Registration

Systems
Components

Services



Solutions

Technical Information

Cerabar T PMC131, PMP131, PMP135

Process pressure measurement

Pressure transducer with ceramic and metallic sensors

For absolute pressure and gauge pressure measurement up to 400 bar (6000 psi); Extremely stable, overload-resistant and reliable



Application

The Cerabar T is a pressure transducer for measuring absolute pressure and gauge pressure in gases, vapors, liquids and dusts. Hygienic and threaded connections are available as process connections.

Your benefits

This compact pressure transducer impresses with its well-engineered construction:

- High reproducibility and long-term stability.
- Finely graduated measuring ranges from vacuum up to 400 bar (6000 psi)
- Ceraphire® ceramic sensor: corrosion-proof, abrasion-proof and extremely overload-resistant
- Deployed for pressure monitoring up to SIL 2 as per IEC 61508/IEC 61511-1
- Sensors
 - Dry capacitance ceramic sensor (Ceraphire®) for measuring ranges up to 40 bar (600 psi): overload-resistant, vacuum-proof, stable against alternating load
 - Piezoresistive sensor with metallic process isolating diaphragm for measuring ranges up to 400 bar (6000 psi)

Table of contents

Function and system design	3	Mechanical construction	12
Device selection	3	PMC131 Housing	12
Measuring principle	3	PMC131 Process connections	12
Measuring system	4	PMP131 and PMP135 Housings	13
Input	4	PMP131 Process connections	13
Measured variable	4	PMP135 Process connections	14
Measuring range	4	Weights	14
Output	4	Material (not wetted)	15
Output signal	4	Material (wetted)	16
Load	4	Operating elements	17
Output signal	4	Operating elements	17
Output current	4	Certificates and approvals	19
Power	5	CE mark	19
Switch frequency	5	Ex approvals	19
Input PLC	5	Pressure Equipment Directive (PED)	19
Inductive loads	5	Functional safety SIL 2	19
Power supply	5	Suitability for hygienic processes	19
PMC131	5	TSE Certificate of Suitability	19
PMP131 and PMP135	6	Standards and guidelines	19
Supply voltage	7	Registered trademarks	20
Residual ripple	7	Ordering information	21
Cable entry	7	PMC131	21
Performance characteristics	8	PMC131 (continued)	22
Reference operating conditions	8	PMP131	23
Long-term stability	8	PMP131 (continued)	24
Reference accuracy	8	PMP135	25
Analog output	8	Accessories	26
Switch point	8	Welding neck with	
Rise time (T90)	8	sealing taper	26
Thermal change in the zero output and the output span	9	Welding neck with	
Temperature coefficient (TK) for lower range value and span	9	sealing surface	26
Operating conditions (installation)	9	Plug-in jack	26
Orientation	9	Connecting cable	26
Installation instructions	9	Plug-on display	26
Location dependence	9	PHX20/PHX21	26
Operating conditions (environment)	10	Documentation	27
Ambient temperature range	10	Field of Activities	27
Storage temperature range	10	Technical Information	27
Climate class	10	Operating Instructions	27
Degree of protection	10	Functional Safety Manual (SIL)	27
Vibration resistance	10	Safety Instructions	27
Electromagnetic compatibility	10	Operating conditions (process)	11
Operating conditions (process)	11	Process temperature range	11
Process temperature range	11	Overload resistance	11
Overload resistance	11	Vacuum resistance	11
Vacuum resistance	11	Pressure specifications	11
Pressure specifications	11		

Function and system design

Device selection

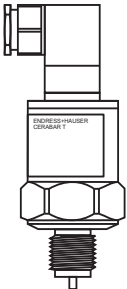
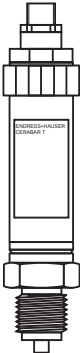
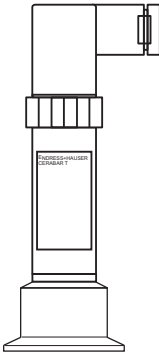
Cerabar T - Product family	PMC131	PMP131	PMP135
	 <small>P01-PMC131xx-14-xx-xx-xx-000</small>	 <small>P01-PMP131xx-14-xx-xx-xx-000</small>	 <small>P01-PMP135xx-14-xx-xx-xx-000</small>
	With capacitive measuring cell and ceramic process isolating diaphragm (Ceraphire®)	With piezoresistive measuring cell and metallic process isolating diaphragm	With piezoresistive measuring cell and metallic process isolating diaphragm for hygienic applications
Field of application	Absolute pressure and gauge pressure	Absolute pressure and gauge pressure	Absolute pressure and gauge pressure in hygienic processes
Output	– Current output 4 to 20 mA	– Current output 4 to 20 mA – Voltage output 0 to 10 V – Switch output PNP	– Current output 4 to 20 mA – Switch output PNP
Process connections	Thread: – G ½ – ½ MNPT and ¼ FNPT – G ½, bore 11 mm (0.43 in)	Thread: – G ½ – ½ MNPT and ¼ FNPT – ½ MNPT, bore 11.4 mm (0.45 in) – G ¼ – ¼ MNPT, bore 3.5 mm (0.14 in) – M 20 x 1.5	Hygiene: – Clamp DN 22 (¾") – Tri-Clamp DN 25 to 38 (1" to 1½") – Tri-Clamp DN 40 to 51 (2") – G 1 – SMS 1½"
Measuring ranges	from –1 to 0 bar (–15 to 0 psi) / –100 to 0 kPa up to 0 to 40 bar (0 to 600 psi) / 0 to 4 MPa	0 to 1 bar (0 to 15 psi) / 0 to 100 kPa up to 0 to 400 bar (0 to 6000 psi) / 0 to 40 MPa	0 to 1 bar (0 to 15 psi)/0 to 100 kPa up to 0 to 40 bar (0 to 600 psi) / 0...4 MPa
Process temperature range	–20 to +100 °C (–4 to +212 °F)	–25 °C to +70 °C (–13 to +158 °F)	–25 to +100 °C (–13 to +212 °F), +135 °C (275 °F) for max. 1 hour

Measuring principle

PMC131

The process pressure causes a slight deflection of the ceramic process isolating diaphragm of the sensor. The pressure-proportional change in capacitance is measured at the electrodes of the ceramic sensor. The ceramic sensor is a dry sensor, i.e. no fill fluid is required for the pressure transfer. This makes the sensor completely suitable for vacuums. Extremely high stability, comparable with the material Alloy, is achieved by using ultrapure Ceraphire® as the ceramic.

PMP131 and PMP135 with analog output

The process pressure acting upon the metallic process isolating diaphragm of the sensor is transmitted to a resistance bridge via a fluid. The pressure-proportional change of the bridge output voltage is measured and processed further.

PMP131 and PMP135 with switch output

The process pressure acting upon the metallic process isolating diaphragm of the sensor is transmitted to a resistance bridge via a fluid. A differential amplifier creates a standard signal from the pressure-proportional change in output voltage of the bridge. A comparator with an adjustable hysteresis compares this signal with the pre-set switch point and then activates the transistor output.

Measuring system

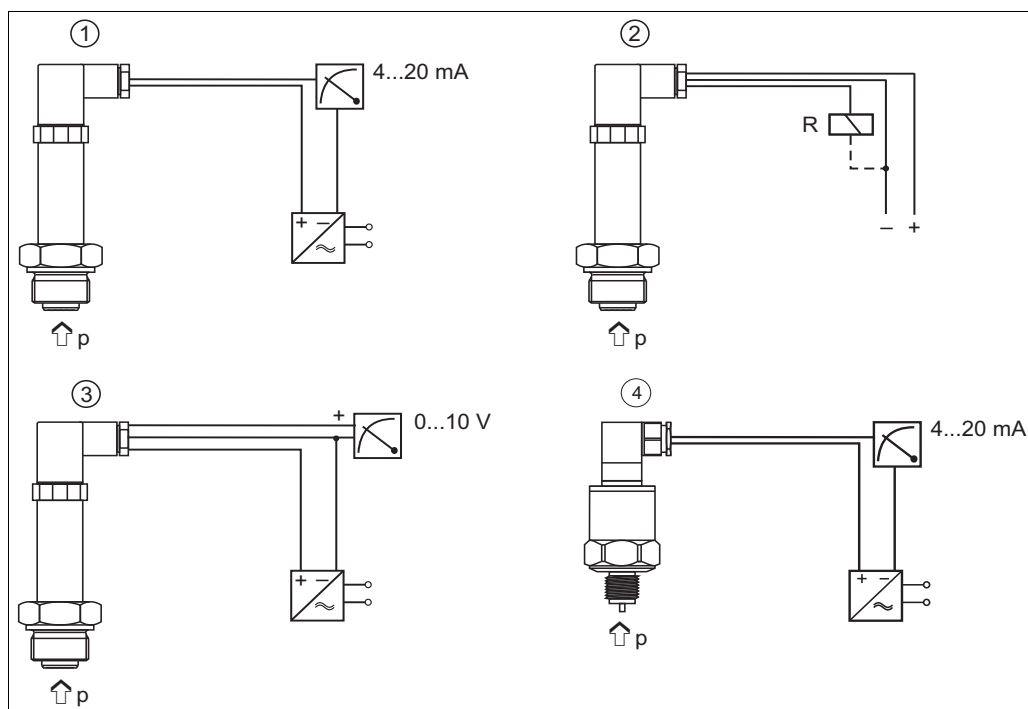

P01-PMx13xxx-14-xx-xx-xx-002

- 1 PMP131, PMP135: current output with transmitter power supply unit, e.g. RN 221N from Endress+Hauser
- 2 PMP131, PMP135: switch output with load, e.g. PLC, DCS, relay
- 3 PMC131: voltage output with transmitter power supply unit, e.g. RIA452 from Endress+Hauser
- 4 PMC131: current output with transmitter power supply unit, e.g. RN 221N from Endress+Hauser

Input

Measured variable	Absolute pressure or gauge pressure
Measuring range	up to 400 bar (6000 psi), → 21, "Ordering information" section

Output

Analog output (PMC131, PMP131, PMP135)

Output signal	Current output 4...20 mA, 2-wire version (PMC131, PMP131, PMP135) Voltage output 0...10 V, 3-wire version (PMP131)
---------------	---

Load	<p>PMC131</p> $R_{Lmax} [\Omega] \leq (U_S - 11 \text{ V}) / 0.02 \text{ A}$ <p>PMP131 and PMP135 (current output)</p> $R_{Lmax} [\Omega] \leq (U_S - 12 \text{ V}) / 0.02 \text{ A} \quad (R_{Lmax}: \text{Maximum load resistance, } U_S: \text{Supply voltage})$
------	---

PMP131 (voltage output)
Load resistance $R_{Lmax} \geq 5 \text{ k}\Omega$, current consumption $\leq 6 \text{ mA}$

Switch output (PMP131, PMP135)

Output signal	PNP switch output (positive voltage signal), rate depends on power supply voltage
---------------	---

Output current	■ Switch status ON: $I_a \leq 500 \text{ mA}$
----------------	---

- Switch status OFF: $I_a \leq 1 \text{ mA}$

Power max. 6 W

Switch frequency max. 10 Hz

Input PLC

- Input resistance $R_i \leq 2 \text{ k}\Omega$
- Input current $I_i \geq 10 \text{ mA}$

Inductive loads To prevent electrical interference, only operate an inductive load (relays, contactors, solenoid valves) when directly connected to a protective circuit (free-wheeling diode or capacitor).

Power supply

PMC131

Plug/cable connection

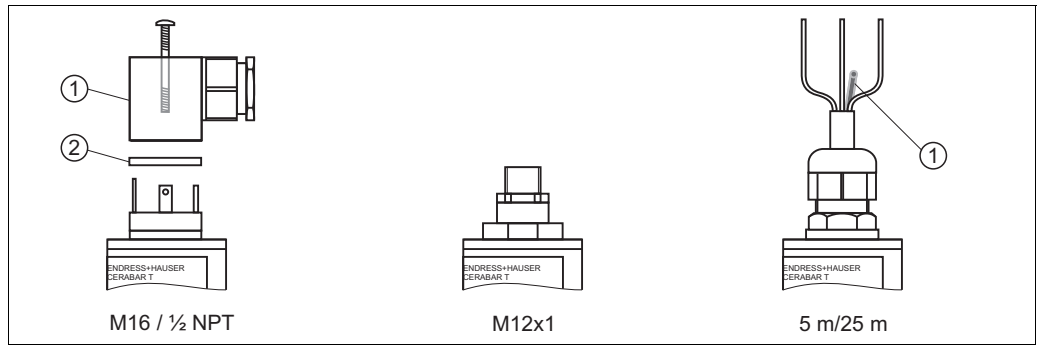

P01-PMC131.xx-04-xx-xx-xx-001

Plug M 16 x 1.5 (DIN 43650/A), 1/2 NPT	Plug M 12x1	5 m (16 ft) / 25 m (82 ft) cable
① Plug-in housing		① Reference pressure line
② Gasket		

Electrical connection: Analog/current output

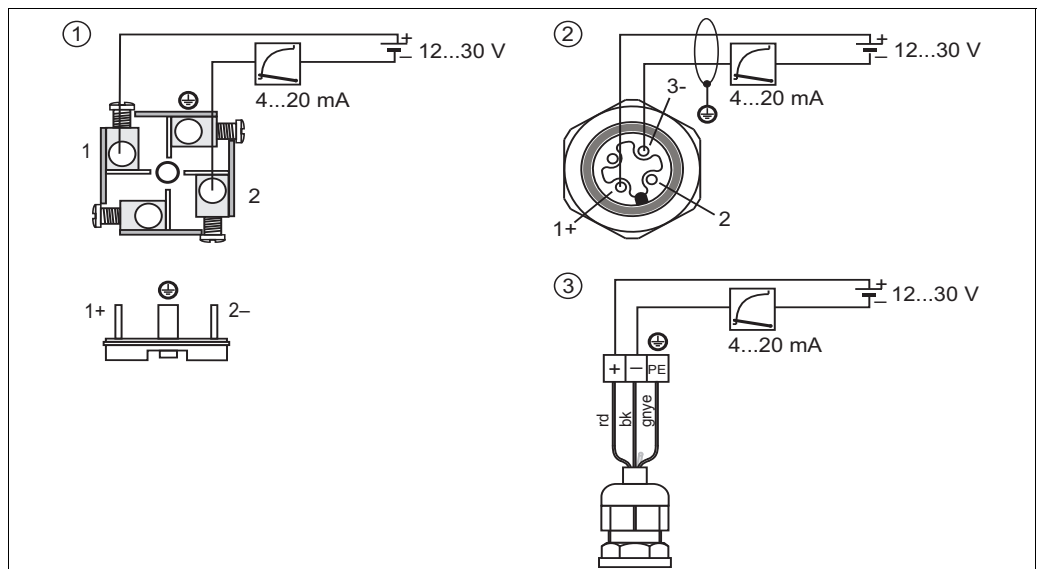

P01-PMC131.xx-04-xx-xx-xx-002

- 1 Plug M 16 x 1.5 (DIN 43650/A), 1/2 NPT
- 2 Plug M 12 x 1
- 3 Cable (rd = red, bk = black, gnye = green-yellow)

PMP131 and PMP135

Plug/cable connection

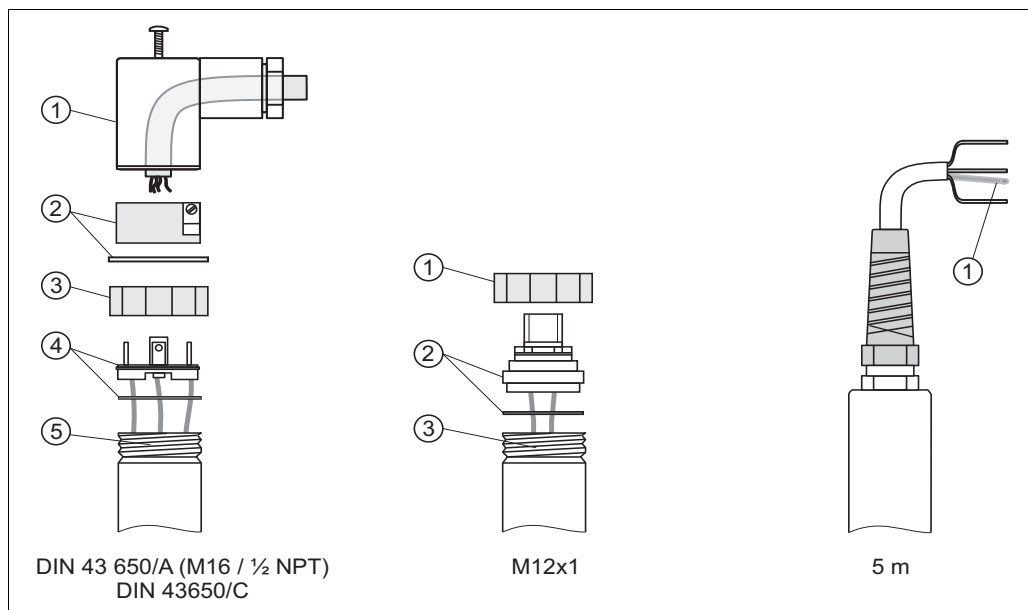

P01-PMP13xxx-04-xx-xx-xx-001

Plug M 16 x 1.5 (DIN 43650/A), 1/2 NPT Plug DIN 43650/C	Plug M 12x1	5 m (16 ft) cable, only analog output
① Plug-in housing	① Coupling nut	① Reference pressure line
② Plug-in jack with gasket	② Connector with gasket	
③ Coupling nut	③ Operating potentiometer (inner)	
④ Plug with O-ring		
⑤ Operating potentiometer (inner)		

Electrical connection: Analog/current output

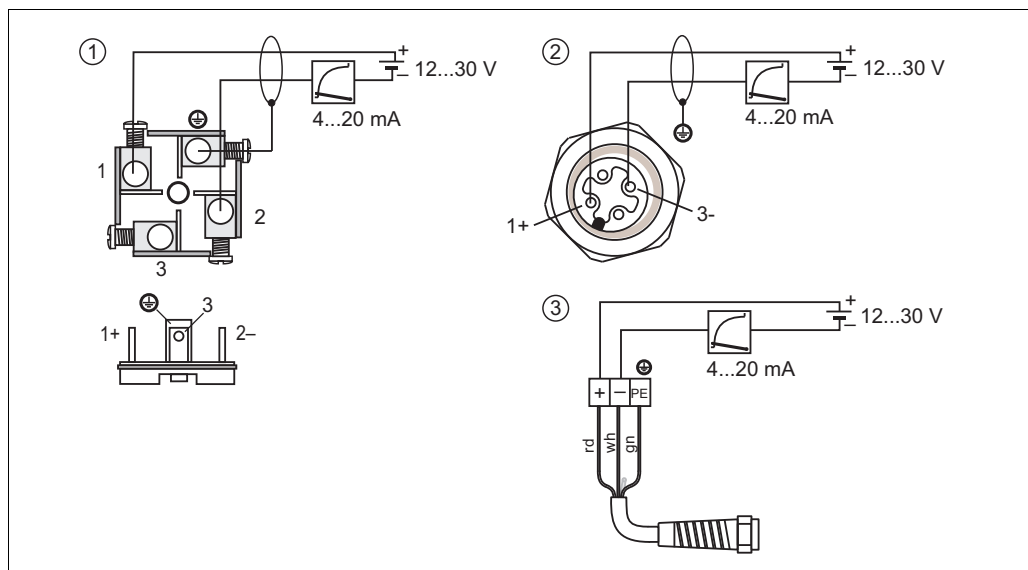

P01-PMP13xxx-04-xx-xx-xx-002

- 1 Plug M 16 x 1.5 (DIN 43650/A), 1/2 NPT and plug DIN 43650/C
- 2 Plug M 12 x 1
- 3 Cable (rd = red, wh = white, gn = green)

For electrical connection provided by customer use only shielded cable

Electrical connection (switch output)

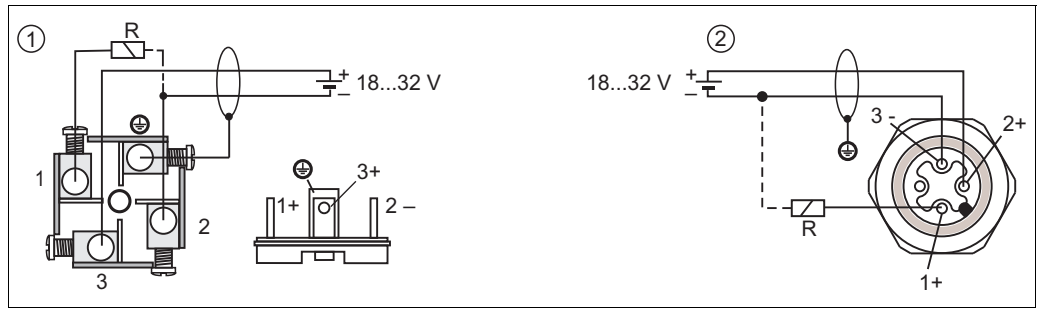

- 1 Plug M 16 x 1.5 (DIN 43650/A), ½ NPT
- 2 Plug M 12 x 1
- R External load, e.g. relay, programmable logic controller, distributed control system

For electrical connection provided by customer use only shielded cable

PMP131 Electrical connection: Analog-/voltage output

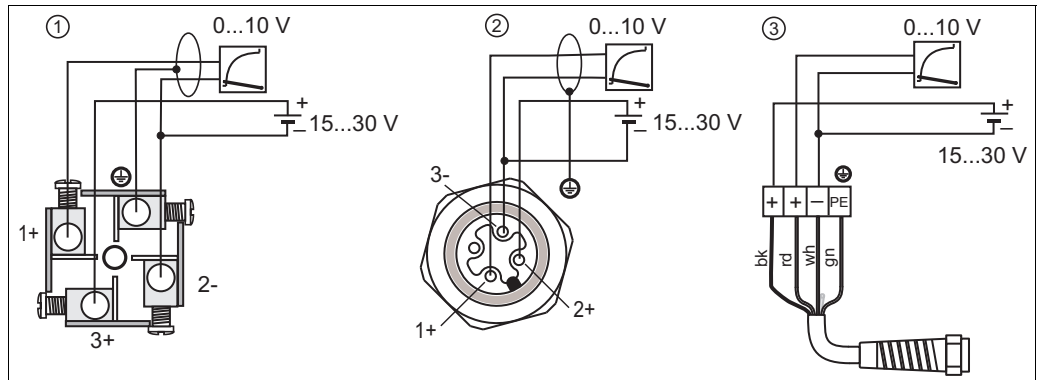

- 1 Plug M 16 x 1,5 (DIN 43650/A), ½ NPT and plug DIN 43 650/C
- 2 Plug M 12 x 1
- 3 Cable (rd = red, wh = white, gn = green)

For electrical connection provided by customer use only shielded cable

Supply voltage

PMC131
11 to 30 V DC

PMP131 and PMP135 (current output, 2-wire version)

- For non-hazardous areas: 12 to 30 V DC
- Ex i: no-load voltage ≤ 26 V DC, short-circuit current ≤ 100 mA, power consumption ≤ 0.8 W

PMP131 (voltage output, 3-wire version)

- 15...30 V DC

PMP131 and PMP135 (switch output)

- 18 to 32 V DC, current consumption without load < 20 mA, with reverse polarity protection

Residual ripple

- Analog output: max. 5 % of supply voltage
- Switch output: max. 10 % of supply voltage

Cable entry

→ 21, "Ordering information" section.

Performance characteristics

Reference operating conditions as per DIN IEC 60770, $T_U = 25\text{ °C}$ (77 °F)

Long-term stability $\leq 0.15\%$ of URL per year

Reference accuracy Analog output The reference accuracy comprises the non-linearity according to limit point setting, hysteresis and non-reproducibility as per IEC 60770.

PMC131

- $\leq 0.5\%$ of nominal value \times TD
(extended specifications apply to customer-specific measuring ranges)

Example: PMC131 version "AIR"

- Nominal value = 10 bar (150 psi)
- Upper range value (URV) = 6 bar (90 psi)
- Lower range value (LRV) = 0 bar

Turn down (is set at factory):

- $\text{Nominal value} / (\text{URV} - \text{LRV}) =$
 $10\text{ bar (150 psi)} / 6\text{ bar (90 psi)} = 10:6$

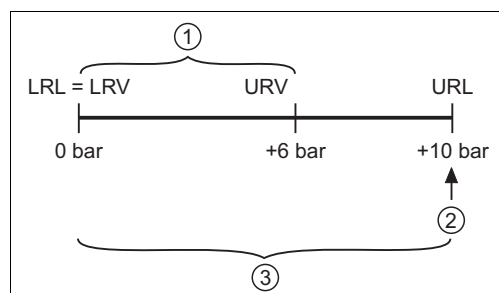

P01-PMx13xxx-05-xx-xx-xx-001

Example: PMC131 version "AIR"
set span: 0 to 6 bar (0 to 90 psi);
nominal value = 10 bar (150 psi)

- 1 Span set and calibrated at the factory (measuring range)
 - 2 Nominal value \cong Upper Range Limit (URL)
 - 3 Sensor measuring range
- LRL Lower Range Limit
URL Upper Range Limit
LRV Lower Range Value
URV Upper Range Value

PMP131 and PMP135

- $\leq 0.5\%$ of URL

Switch point **PMP131 and PMP135**

- Deviation: $\leq 1\%$ of URL
- Non-reproducibility: $\leq 0.5\%$ of URL

Rise time (T90) **PMC131**
20 ms

PMP131 and PMP135
2 to 5 ms

Thermal change in the zero output and the output span	<p>PMC131</p> <p>For customer-specific measuring-ranges: values are doubled</p> <p>Zero output, -20 to +85 °C (-4 to +185 °F):</p> <ul style="list-style-type: none"> ■ typically 1.5 % of nominal value <p>Output span, -20 to +85 °C (-4 to +185 °F):</p> <ul style="list-style-type: none"> ■ Nominal value 0.4 to 40 bar (6 to 600 psi): typically 0.8 % of nominal value ■ Nominal value 0.1 to 0.2 bar (1.5 to 3 psi): typically 1.0 % of nominal value
--	---

Temperature coefficient (T_K) for lower range value and span	<p>PMP131 and PMP135 (analog output)</p> <p>Zero output:</p> <ul style="list-style-type: none"> ■ typically: 0.2 % of URL/10 K ■ max.: 0.5 % of URL/10 K ■ Nominal value ≤ 6 bar (90 psi): by 0.1 % of URL/10 K higher <p>Output signal:</p> <ul style="list-style-type: none"> ■ typically: 0.2 % of URL/10 K ■ max.: 0.5 % of URL/10 K <p>PMP131 and PMP135 (switch output)</p> <p>Switch point:</p> <ul style="list-style-type: none"> ■ typically: 0.2 % of URL/10 K ■ max.: 0.5 % of URL/10 K
---	---

Operating conditions (installation)

Orientation	anywhere
Installation instructions	<p>PMP131</p> <p>Process connection G ½ flush-mounted, max. torque 40 Nm (29.5 lbf ft)</p>
Location dependence	<p>PMC131</p> <p>without influence</p> <p>PMP131 and PMP135</p> <p>Position-dependent zero point shift can be corrected by potentiometer setting, →  17.</p>

Operating conditions (environment)

Ambient temperature range	<p>PMC131 -20 to +85 °C (-4 to +185 °F)</p> <p>PMP131 and PMP135</p> <ul style="list-style-type: none"> ■ For non-hazardous areas: -25 to +70 °C (-13 to +158 °F) ■ Ex i: -25 to +65 °C (-13 to +149 °F)
Storage temperature range	<p>PMC131 -50 to +100 °C (-58 to +212 °F)</p> <p>PMP131 and PMP135 -40 to +85 °C (-40 to +185 °F)</p>
Climate class	<p>PMC131 4K4H as per DIN EN 60721-3</p> <p>PMP131 and PMP135 4Z with Z = 70 °C (158 °F) as per VDI/VDE 3540</p>
Degree of protection	<p>PMC131</p> <ul style="list-style-type: none"> ■ Plug M 16 x 1,5 (DIN 43650/A), ½ NPT: IP 65/NEMA 4X ■ Plug M12x1: IP 65/ NEMA 4 ■ Cable: IP 68/NEMA 6P (1 mWS/24 h) <p>PMP131 and PMP135</p> <ul style="list-style-type: none"> ■ Plug M 16 x 1,5 (DIN 43650/A), ½ NPT: IP 65/NEMA 4X ■ Plug M 12x1 and gauge pressure sensors: IP 65/NEMA 4X ■ Plug M 12x1 and absolute pressure sensors: IP 68/NEMA 6P (1 mWS/24 h) ■ Cable: IP 68/NEMA 6P (1 mWS/24 h)
Vibration resistance	4M5 as per DIN EN 60721-3
Electromagnetic compatibility	EMC in accordance with all the relevant requirements of the EN 61326 series. Details are provided in the Declaration of Conformity.

Operating conditions (process)

Process temperature range

PMC131

- -20 to +100 °C (-4 to 212 °F)
- Devices for oxygen application: -10 to +60 °C (14 to 140 °F)
(Version "S" for feature 30 "Sensor gasket")

PMP131

-25 to +70 °C (-13 to +158 °F)

PMP135

-25 to +100 °C (-13 to 212 °F), +135 °C (275 °F) for max. 1 hour

Extreme jumps in temperature can result in temporary measuring errors. Temperature compensation takes effect after several minutes. Internal temperature compensation is faster the smaller the temperature jump and the longer the time interval.

Overload resistance

→  21, "Ordering information" section.

Vacuum resistance

PMC131



URV	Vacuum resistance	Version
0...100 mbar (0...1.5 psi)	700 mbar _{abs} (10.5 psi _{abs})	D10
20 mbar (0.3 psi)		D3W
100 mbar (1.5 psi)		D31
1.5 psi (100 mbar)		V6F
0...1.5 psi (0...100 mbar)		Q4D
15 inH ₂ O		W6N
30 inH ₂ O		W6R
0...200 mbar (0...3 psi)	500 mbar _{abs} (7.5 psi _{abs})	D12
200 mbar (3 psi)		D38
50 inH ₂ O		S4N
80 inH ₂ O		W6O
all other versions	0 mbar _{abs}	

PMP131 and PMP135

10 mbar_{abs} (0.15 psi_{abs})

The vacuum resistance applies for the measuring cell under reference operating conditions.

Pressure specifications

- The MWP (maximum working pressure) of the device is specified on the nameplate. It depends on the weakest element, with regard to pressure, of the selected components. See the following sections:
 - →  21 ff, "Ordering information" section, feature 50 "Measuring range; MWP; Nominal value; OPL" or "Sensor range; MWP; OPL".
 - →  12 ff, "Mechanical construction" section.
 The MWP specification on the nameplate is based on a reference temperature of +20 °C (68 °F) and can be present over an unlimited period of time.
- The test pressure corresponds to the overload limit of the measuring device (Over Pressure Limit OPL) and must only be present for a limited period of time.

Mechanical construction

PMC131 Housing

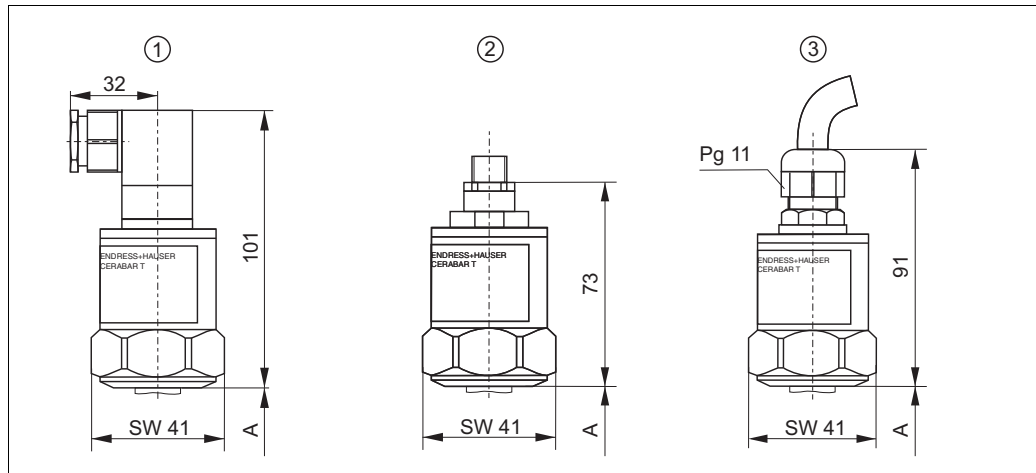

P01-PMC131xx-06-xx-xx-xx-001

Housing PMC131; Material AISI 304 (1.4301)

- 1 Versions A1, A2, B1, C1, C2: Plug M 16 or 1/2 NPT (ISO 4400), IP 65
- 2 Versions A5, B5, C5: Plug M 12, IP 65
- 3 Versions A3, A4, B3, C3: 5 m (16 ft) or 25 m (82 ft) cable, IP 68

→ See the following diagram for the height of process connection A

PMC131 Process connections

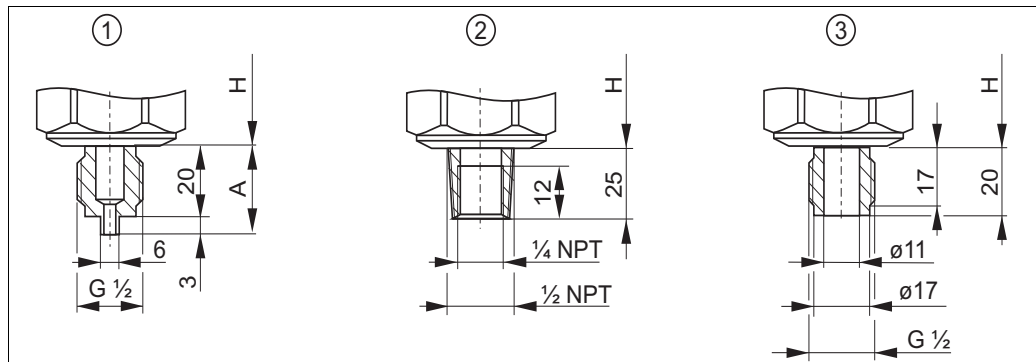

P01-PMC131xx-06-xx-xx-xx-002

Process connections PMC131; Material AISI 304 (1.4301)

- 1 Version 1: Thread ISO 228 G 1/2
- 2 Version 2: Thread ANSI 1/2 MNPT 1/4 FNPT
- 3 Version 5: Thread ISO 228 G 1/2, bore 11 mm (0.43 in)

→ See respective housing for installation height H (previous figure)

PMP131 and PMP135 Housings

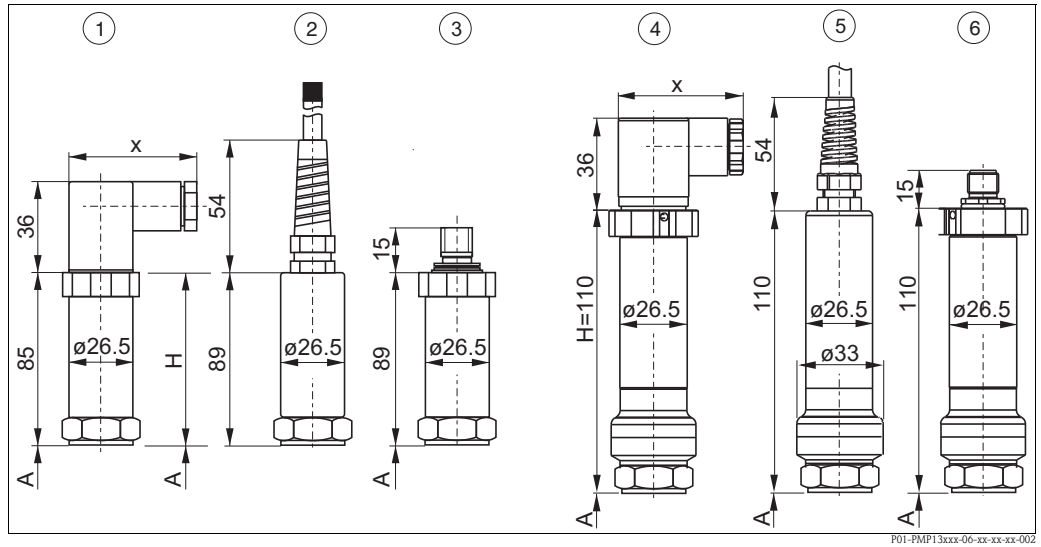

Housings PMP131 and PMP135; Material AISI 304 (1.4301)

- 1...3 PMP131 and PMP135 with sensor range up to 60 bar (900 psi)
- 4...6 PMP131 with sensor range up to 400 bar (6000 psi)
- 1 + 4 Versions A1, A2: Plug M 16 (DIN 43650/A) or 1/2 NPT (ISO 4400), IP 65; dimension x = 52 mm (2.05 in)
- Version A5: Plug DIN 43650/C, IP 65; dimension x = 42 mm (1.65 in)
- 2 + 5 Version A3: 5 m (16 ft) cable, IP 68
- 3 + 6 Version A4: Plug M 12, IP 65

→ See the following figure for the dimensions of process connection A

PMP131 Process connections

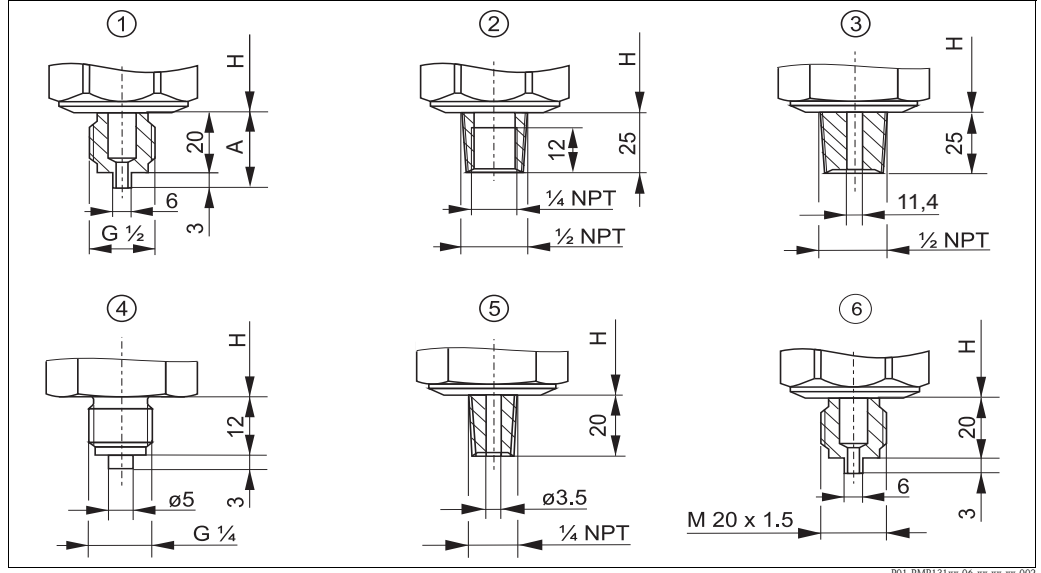

Process connections PMP131; Material AISI 304 (1.4301)

- 1 Version 1: Thread ISO 228 G 1/2
- 2 Version 2: Thread ANSI 1/2 MNPT 1/4 FNPT
- 3 Version 3: Thread ANSI 1/2 MNPT, bore 11.4 mm (0.45 in) female
- 4 Version 4: Thread ISO 228 G 1/4
- 5 Version 5: Thread ANSI 1/4 MNPT, bore 3.5 mm (0.14 in) female
- 6 Version 6: Thread M 20 x 1.5

→ See respective housing for installation height H (figure above)
 → Process connections with AF 27 mm

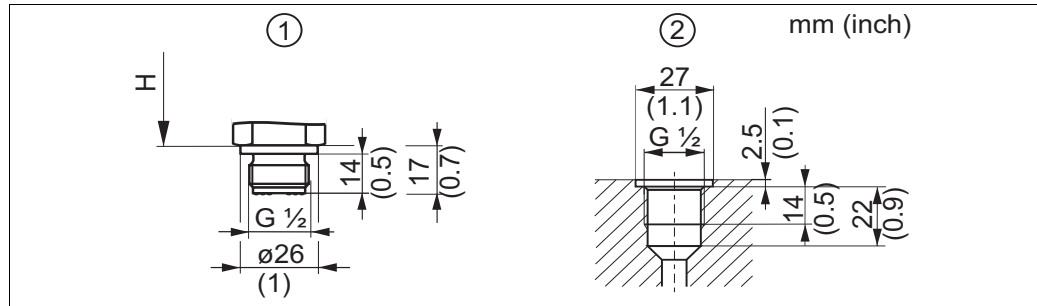

P01-PMP131xx-06-09-xx-xx-002

Process connection PMP131; Material AISI 304 (1.4301)

- 1 Version B: Thread ISO 228 G 1/2, Seal seat as per DIN 3852-A, AISI 304, flush-mounted
- 2 Dimensions for tapped hole G 1/2 as per DIN 3852-11 form X

→ See respective housing for installation height H

PMP135 Process connections

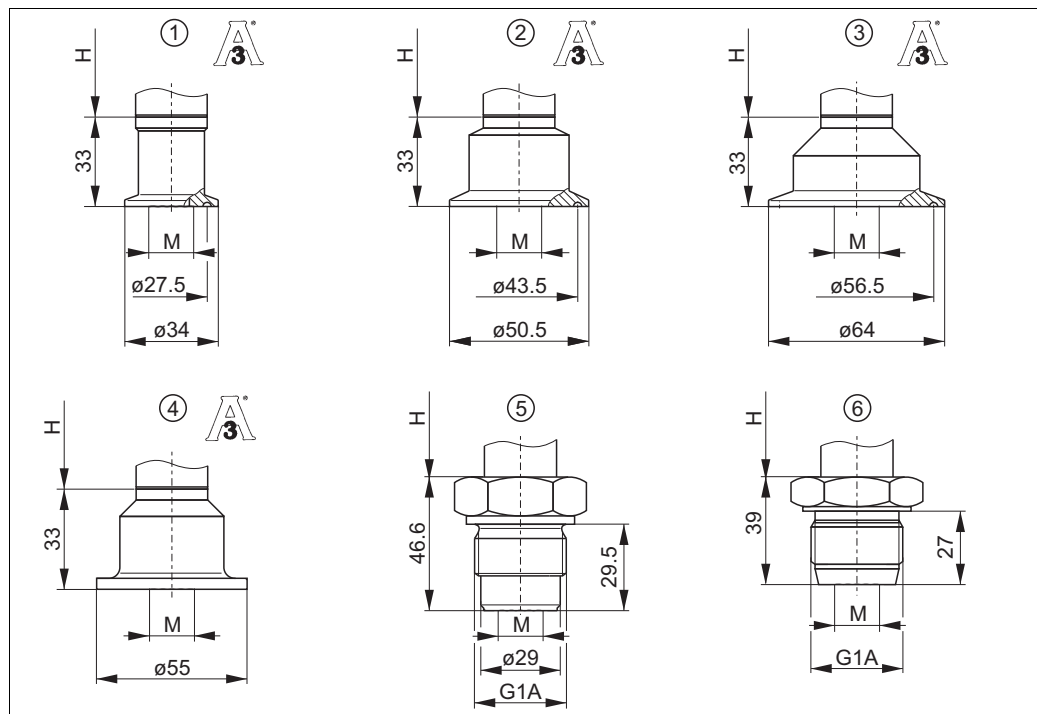

P01-PMP135xx-06-xx-xx-xx-001

Process connections PMP135; Material AISI 316L (1.4435); Surface roughness of the surfaces in contact with the media $R_a \leq 0.8 \mu\text{m}$

M = Diaphragm diameter 17.2 mm (0.68 in)

- 1 Version F: Clamp DN18-22 3/4" (DIN 32676), 3A
- 2 Version G: Tri-Clamp 1" to 1 1/2" (ISO 2852) or DN 25 to DN 40 (DIN 32676), 3A
- 3 Version H: Tri-Clamp 2" (ISO 2852) or DN 50 (DIN 32676), 3A
- 4 Version S: SMS 1 1/2" PN 25, 3A
- 5 Version N: G1A (ISO 228), with sealing surface for flush-mounted installation
- 6 Version M: G1A (ISO 228), with metallic sealing taper, flush-mounted

3A approval in combination with o-ring seal and welding neck 52001051 (see → 26)

→ See respective housing for installation height H

Weights

- PMC131: approx. 0.32 kg (0.71 lbs)
- PMP131: approx. 0.24 kg (0.53 lbs) up to 60 bar (870 psi), approx. 0.32 kg (0.71 lbs) up to 400 bar (5800 psi)
- PMP135: approx. 0.34 kg (0.75 lbs)

Material (not wetted)

Housing

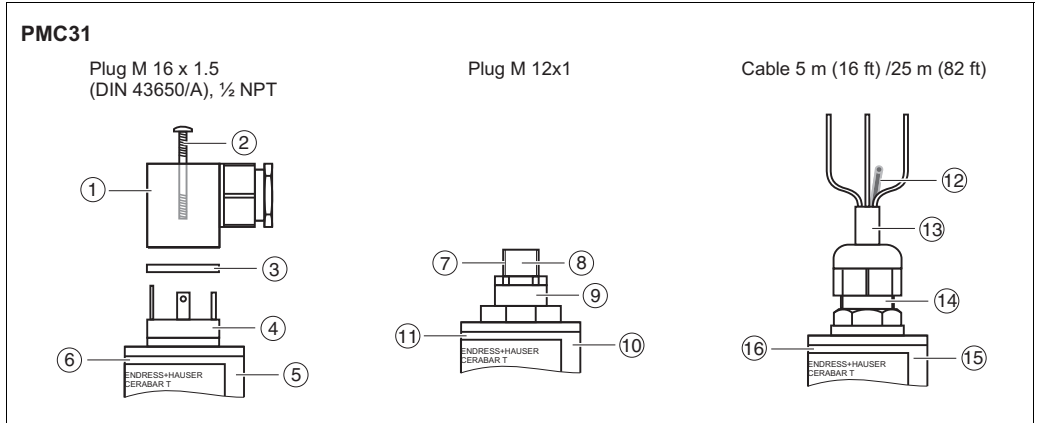

Item number	Component part	Material
1	Plug housing	PA6 GF
2	Flat sealing	NBR
3	Screw M3 x 35	A2
4	Connection cover	PBT-FR
5	O-ring	NBR
6	Housing	1.4301
7	O-ring for connector	FKM
8	Inner connector	PA
9	M12 connector	GD-Zn, nickel-plated
10	O-ring	NBR
11	Housing	1.4301
12	Hose	PA
13	Cable	PE
14	Gland	PBT
15	O-ring	NBR
16	Housing	1.4301

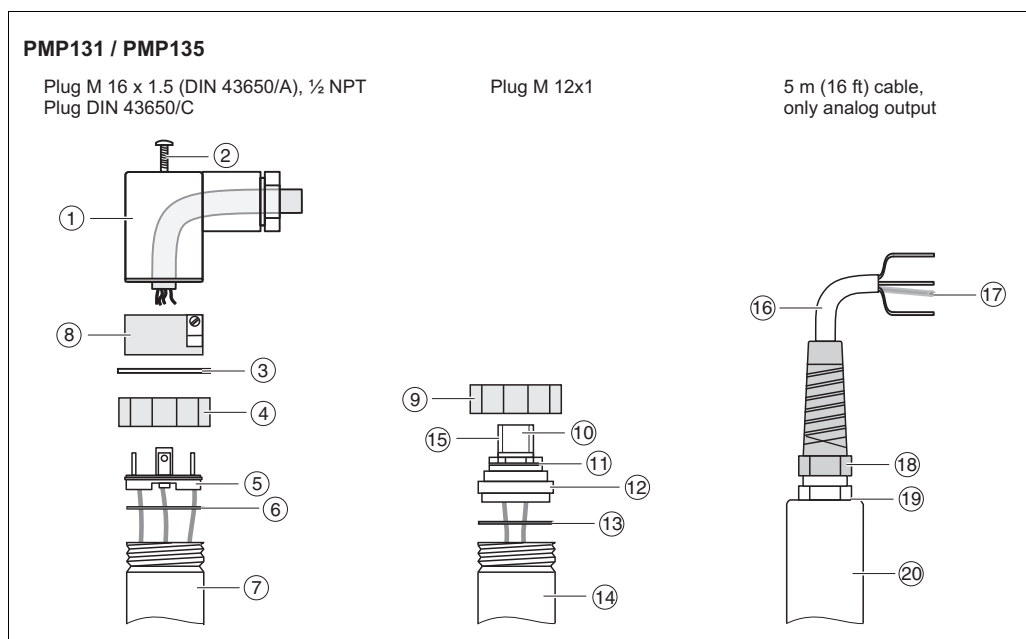

Item number	Component part	Material
1	Plug housing	PA6 GF
2	Screw M3 x 35	A2
3	Flat sealing	NBR
4	Coupling nut	PA
5	Cover plug	PA66 GF
6	O-ring	NBR
7	Housing	1.4301
8	Plug	PA66 GF
9	Coupling nut	PA
10	Inner connector	PA
11	O-ring	NBR
12	M12 connector	GD-Zn, nickel-plated
13	O-ring	NBR
14	Housing	1.4301
15	O-ring for connector	FKM
16	Cable	PUR
17	Hose	PA
18	Anti-jackknife	PA
19	O-ring	NBR
20	Housing	1.4301

Fill oil:

- PMP131: Tegiloxan 3
- PMP135: Mineral oil, FDA number 21-CFR 178.3570

Material (wetted)

Note!

The wetted device components are listed in the "Mechanical construction" (→ 12 ff) and "Ordering information" (→ 21 ff) sections.

Process connection

- PMC131/PMP131: AISI 304 (1.4301)
- PMP135: AISI 316L (1.4435)

Process isolating diaphragm

- PMC131: Ceraphire® (99,9 % Al₂O₃), FDA number 21-CFR 186.1256
- PMP131, PMP135: AISI 316L (1.4435)

Operating elements

Operating elements

Position of operating elements

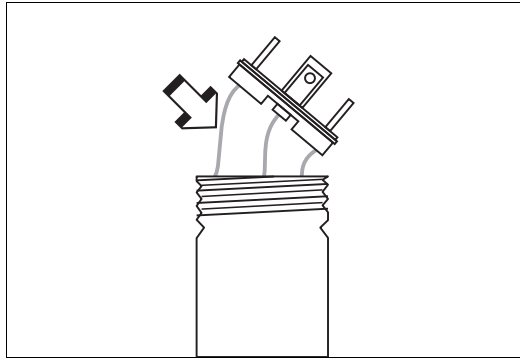

P01-PMx13xxx-19-xx-xx-xx-003

The potentiometer for operating the Cerabar T PMP131 and PMP135 with analog or switch output is located below the base of the plug.

Analog output: Zero point adjustment

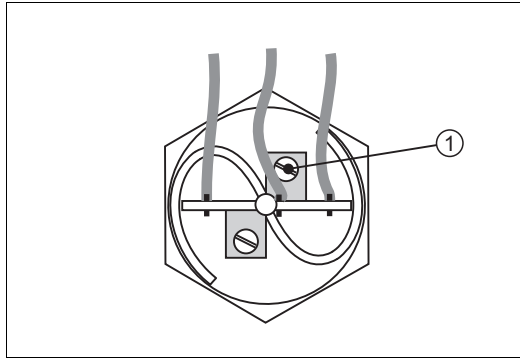

P01-PMx13xxx-19-xx-xx-xx-001

The zero point can be corrected for the Cerabar T PMP131 and PMP135 with analog output and plug version.

1 Potentiometer for zero point correction by $\pm 5\%$ of URL

Switch output: Switch point and hysteresis adjustment

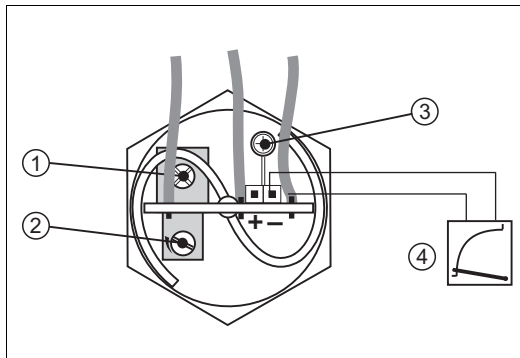

P01-PMx13xxx-19-xx-xx-xx-002

For the Cerabar T PMP131 and PMP135 with switch output, both the switch point and hysteresis can be adjusted.

This can also be carried out at atmospheric pressure using the enclosed test cable and a voltmeter.

- 1 Hysteresis adjustment 1.5 to 20 % of URL;
Factory setting 10 % of URL
- 2 Switch point adjustment 0 to 100 % of URL;
Factory setting 50 % of URL
- 3 LED color code for checking the switch status:
green = off; red = on
- 4 Connect voltmeter to test pins:
0 to 1 V corresponds to 0 to 100 % of URL

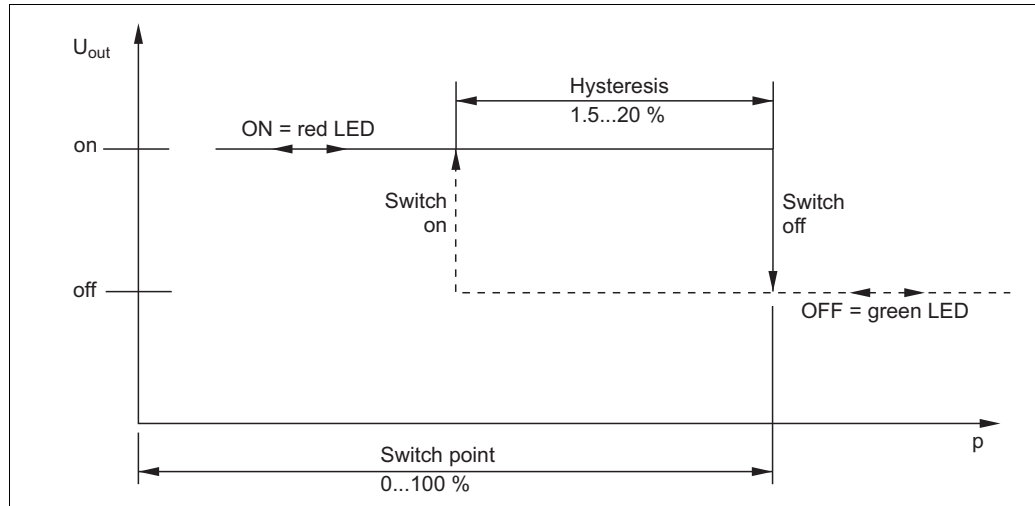

P01-PMPT 3xxx-05-xx-xx-en-001

Instructions for switch point and hysteresis (the percentage values refer to the URL)

U_a Output voltage
 p Acting pressure

Certificates and approvals

CE mark	The device meets the legal requirements of the EC directives. Endress+Hauser confirms that the device has been successfully tested by applying the CE mark.
Ex approvals	All explosion protection data are given in separate documentation which is available upon request. The Ex documentation is supplied as standard with all devices approved for use in explosion hazardous areas. See also →  27, "Safety Instructions" section.
Pressure Equipment Directive (PED)	This measuring device corresponds to Article 3 (3) of the EC directive 97/23/EC (Pressure Equipment Directive) and has been designed and manufactured according to good engineering practice.
Functional safety SIL 2	The Cerabar T PMP131 and PMP135 pressure transducers with 4 to 20 mA electronics have been assessed by an independent body according to the standards IEC 61508/IEC 61511-1. These devices can be used for monitoring process pressure up to SIL 2. → For a detailed description of safety functions with Cerabar T, settings and characteristic quantities for functional safety, see the "Functional Safety Manual – Cerabar T SD00160P".
Suitability for hygienic processes	<p>All materials in contact with foodstuffs comply with framework Regulation (EC) 1935/2004. The device is available with hygienic process connections (overview: see order code).</p> <p>Caution! Risk of contamination if incorrect seals and parts are used!</p> <ul style="list-style-type: none"> ■ To avoid the risk of contamination, when installing the device comply with the design principles of EHEDG, Guideline 37 "Hygienic Design and Application of Sensors" and Guideline 16 "Hygienic Pipe Couplings". ■ Suitable assemblies and seals must be used to ensure hygienic design in accordance with 3-A SSI and EHEDG specifications. ■ The leak-proof connections can be cleaned with the cleaning methods typical of this industry (CIP and SIP). Attention must be paid to the pressure and temperature specifications of the sensor and process connections for CIP and SIP processes (clean in place/sterilize in place).
TSE Certificate of Suitability	<p>Cerabar T PMP135</p> <p>The following applies to wetted device components: They do not contain any materials derived from animals. No auxiliaries or operating materials derived from animals are used in production or processing. Process wetted device components are listed in the "Mechanical construction" and "Ordering information" sections.</p>
Standards and guidelines	<p>DIN EN 60770 (IEC 60770): Transmitters for controlling in systems used in industrial process technology Part 1: Methods for evaluating the operating behavior.</p> <p>DIN EN 61003-1, Edition:1993-12 Systems used in industrial process technology; Devices with analog inputs and two-point or multi-point behavior; Part 1: Methods for evaluating the operating behavior.</p> <p>DIN 16086: Electrical pressure measuring devices, pressure sensors, transmitters, pressure measuring devices Terms, specifications in data sheets.</p> <p>IEC 60529 Degrees of protection provided by enclosures (IP-Code).</p> <p>EN 61326: Electrical equipment for control technology and laboratory application – EMC requirements.</p> <p>IEC 61010 Safety requirements for electrical equipment for measurement, control and laboratory use.</p> <p>NAMUR Association for Standards for Control and Regulation in the Chemical Industry.</p>



74 -

Registered trademarks

Ceraphire®
Registered trademark of Endress+Hauser GmbH+Co. KG, Maulburg, Germany
(→ see also www.endress.com/ceraphire)

Ordering information

PMC131

This overview does not mark options which are mutually exclusive.

10		Electrical connection:			
A1	Plug ISO 4400, M 16, IP 65/NEMA 4X				
A2	Plug ISO 4400, ½ NPT, IP 65/NEMA 4X				
A3	5 m cable, IP 68/NEMA 6P				
A4	25 m cable, IP 68/NEMA 6P				
A5	Plug M 12, IP 65/NEMA 4				
B1	Plug ISO 4400, M 16, IP 65, ATEX II 3 G Ex nA II T4				
B3	5 m cable, IP 68, ATEX II 3 G Ex nA II T4				
B5	Plug M 12, IP 65, ATEX II 3 G Ex nA II T4				
C1	Plug ISO 4400, M 16, NEMA 4X, CSA GP				
C2	Plug ISO 4400, ½ NPT, NEMA 4X, CSA GP				
C3	5m cable, IP 68/NEMA 6P, CSA GP				
C5	Plug M12, IP 65/NEMA 4, CSA GP				
20		Process connection:			
1	Thread ISO 228 G ½, AISI 304				
2	Thread ANSI ½ MNPT ¼ FNPT, AISI 304				
5	Thread ISO 228 G ½ bore 11 mm, AISI 304				
30		Sensor seal:			
E	EPDM				
F	FKM Viton				
S	FKM Viton, oxygen application				
40		Additional options:			
1	Without additional equipment				
S	GL (German Lloyd) marine certificate				
2	Final inspection report				
50		Measuring range; MWP; Nominal value; OPL:			
		Measuring range	MWP (Maximum Working Pressure)	Nominal value	OPL (Over Pressure Limit)
		Sensors for gauge pressure			
	A1G	0 to 1 bar / 0 to 100 kPa	6.7 bar	1 bar	10 bar / 1 MPa
	A1H 1)	0 to 1.6 bar / 0 to 160 kPa	12 bar	2 bar	18 bar / 1.8 MPa
	A1K	0 to 2 bar / 0 to 200 kPa	12 bar	2 bar	18 bar / 1.8 MPa
	A1Q	0 to 4 bar / 0 to 400 kPa	16.7 bar	4 bar	25 bar / 2.5 MPa
	A1R 1)	0 to 6 bar / 0 to 600 kPa	26.7 bar	10 bar	40 bar / 4 MPa
	A1S	0 to 10 bar / 0 to 1 MPa	26.7 bar	10 bar	40 bar / 4 MPa
	A1T 1)	0 to 16 bar / 0 to 1.6 MPa	26.7 bar	20 bar	40 bar / 4 MPa
	A1V	0 to 20 bar / 0 to 2 MPa	26.7 bar	20 bar	40 bar / 4 MPa
	A1W 1)	0 to 25 bar / 0 to 2.5 MPa	40 bar	40 bar	60 bar / 6 MPa
	A1X	0 to 40 bar / 0 to 4 MPa	40 bar	40 bar	60 bar / 6 MPa
	A3C 1)	-1 to 0 bar / -100 to 0 kPa	6.7 bar	2 bar	10 bar / 1 MPa
	A3E 1)	-1 to 1 bar / -100 to 100 kPa	6.7 bar	2 bar	10 bar / 1 MPa
	A3G 1)	-1 to 3 bar / -100 to 300 kPa	16.7 bar	4 bar	25 bar / 2.5 MPa
	A3K 1)	-1 to 9 bar / -100 to 900 kPa	26.7 bar	10 bar	40 bar / 4 MPa
	A3N 1)	-1 to 15 bar / -0.1 to 1.5 MPa	26.7 bar	20 bar	40 bar / 4 MPa
	D10	0 to 100 mbar / 0 to 10 kPa	2.7 bar	0.1 bar	4 bar / 400 kPa
	D12 1)	0 to 200 mbar / 0 to 20 kPa	3.3 bar	0.2 bar	5 bar / 500 kPa
	D14	0 to 400 mbar / 0 to 40 kPa	5.3 bar	0.4 bar	8 bar / 800 kPa
	D3W	-20 to 20 mbar / -2 to 2 kPa	2.7 bar	0.2 bar	4 bar / 400 kPa
	D31 1)	-100 to 100 mbar / -10 to 10 kPa	3.3 bar	0.2 bar	5 bar / 500 kPa
	D38 1)	-200 to 200 mbar / -20 to 20 kPa	3.3 bar	0.4 bar	5 bar / 500 kPa
	D39 1)	-300 to 300 mbar / -30 to 30 kPa	5.3 bar	1 bar	8 bar / 800 kPa
PMC131					Order code

→ For continuation of ordering information of PMC131, see the following page.

1) Span set and calibrated at the factory

PMC131 (continued)

50				Measuring range; MWP; Nominal value; OPL:			
				Measuring range	MWP (Maximum Working Pressure)	Nominal value	OPL (Over Pressure Limit)
				Sensors for gauge pressure			
				Q4D 0 to 1.5 psi	40 psi	1.5 psi	60 psi
				Q4F 1) 0 to 5 psi	80 psi	6 psi	120 psi
				Q4H 0 to 15 psi	100 psi	15 psi	150 psi
				Q4K 0 to 30 psi	180 psi	30 psi	270 psi
				Q4N 1) 0 to 50 psi	250 psi	60 psi	375 psi
				Q4R 0 to 150 psi	400 psi	150 psi	600 psi
				Q4S 0 to 300 psi	400 psi	300 psi	600 psi
				Q4T 1) 0 to 500 psi	600 psi	600 psi	900 psi
				V6F 1) -1.5 to 1.5 psi	50 psi	3 psi	75 psi
				V6N 1) -15 to 15 psi	100 psi	30 psi	150 psi
				V6R 1) -15 to 30 psi	250 psi	60 psi	375 psi
				V6S -15 to 60 psi	250 psi	60 psi	375 psi
				V6V -15 to 150 psi	400 psi	150 psi	600 psi
				S4N 1) 0 to 50 inH ₂ O	50 psi	3 psi	75 psi
				S4Q 1) 0 to 100 inH ₂ O	80 psi	6 psi	120 psi
				W6N 1) -15 to 15 inH ₂ O	40 psi	3 psi	60 psi
				W6O 1) -80 to 80 inH ₂ O	50 psi	6 psi	75 psi
				W6R 1) -15 to 30 inH ₂ O	50 psi	3 psi	75 psi
				Sensors for absolute pressure			
				A2G 0 to 1 bar / 0 to 100 kPa	6.7 bar	1 bar	10 bar / 1 MPa
				A2H 1) 0 to 1.6 bar / 0 to 160 kPa	12 bar	2 bar	18 bar / 1.8 MPa
				A2K 0 to 2 bar / 0 to 200 kPa	12 bar	2 bar	18 bar / 1.8 MPa
				A2Q 0 to 4 bar / 0 to 400 kPa	16.7 bar	4 bar	25 bar / 2.5 MPa
				A2R 1) 0 to 6 bar / 0 to 600 kPa	26.7 bar	10 bar	40 bar / 4 MPa
				A2S 0 to 10 bar / 0 to 1 MPa	26.7 bar	10 bar	40 bar / 4 MPa
				A2T 1) 0 to 16 bar / 0 to 1.6 MPa	26.7 bar	20 bar	40 bar / 4 MPa
				A2V 0 to 20 bar / 0 to 2 MPa	26.7 bar	20 bar	40 bar / 4 MPa
				A2W 1) 0 to 25 bar / 0 to 2.5 MPa	40 bar	40 bar	60 bar / 6 MPa
				A2X 0 to 40 bar / 0 to 4 MPa	40 bar	40 bar	60 bar / 6 MPa
				D20 1) 0 to 100 mbar / 0 to 10 kPa	3.3 bar	0.2 bar	5 bar / 500 kPa
				D22 0 to 200 mbar / 0 to 20 kPa	3.3 bar	0.2 bar	5 bar / 500 kPa
				D24 0 to 400 mbar / 0 to 40 kPa	5.3 bar	0.4 bar	8 bar / 800 kPa
				R4D 1) 0 to 1.5 psi	50 psi	3 psi	75 psi
				R4F 1) 0 to 5 psi	80 psi	6 psi	120 psi
				R4H 0 to 15 psi	100 psi	15 psi	150 psi
				R4K 0 to 30 psi	180 psi	30 psi	270 psi
				R4N 1) 0 to 50 psi	250 psi	60 psi	375 psi
				R4R 0 to 150 psi	400 psi	150 psi	600 psi
				R4S 0 to 300 psi	400 psi	300 psi	600 psi
				R4T 1) 0 to 500 psi	600 psi	600 psi	900 psi
995				Marking			
				1	Tagging (TAG), see additional spec.		
PMC131					Complete order code		

1) Span set and calibrated at the factory

PMP131

This overview does not mark options which are mutually exclusive.

10	Electrical connection:			
	A1	Plug ISO 4400, M 16, IP 65/NEMA 4X (DIN 43650/A)		
	A2	Plug ISO 4400, ½ NPT, IP 65/NEMA 4X		
	A3	5 m cable, IP 68/NEMA 6P		
	A4	Plug M 12, IP 65/NEMA 4X		
	A5	Plug DIN 43650/C, IP65, NEMA 4X		
20	Process connection:			
	B	Thread ISO 228 G ½, Seal seat as per DIN 3852, AISI 304, flush-mounted		
	1	Thread ISO 228 G ½, AISI 304		
	2	Thread ANSI ½ MNPT ¼ FNPT, AISI 304		
	3	Thread ANSI ½ MNPT bore 11.4 mm, AISI 304		
	4	Thread ISO 228 G ¼, AISI 304		
	5	Thread ANSI ¼ MNPT bore 3.5 mm, AISI 304		
	6	Thread M 20 x 1.5		
30	Output:			
	0	Analog current output 4 to 20 mA, SIL		
	D	Analog current output 4 to 20 mA, SIL, ATEX II 1/2 G Ex ib IIC T6		
	1	Analog current output 4 to 20 mA, SIL, ATEX II 2 G Ex ib IIC T6		
	5	Analog current output 4 to 20 mA, SIL, ATEX II 3 G Ex nA II T6		
	2	Switch output PNP, 3-wire		
	3	Switch output PNP, 3-wire, ATEX II 3 G Ex nA II T6		
	6	Analog voltage output 0...10 V		
40	Additional options:			
	1	Without additional equipment		
	S	GL/RINA marine approval		
	2	Final inspection report		
50	Sensor range; MWP; OPL:			
		Sensor range	MWP (maximum working pressure)	OPL (over pressure limit)
		Sensors for gauge pressure		
	A1G	0 to 1 bar / 0 to 100 kPa	2.7 bar	4 bar / 400 kPa
	A1H	0 to 1.6 bar / 0 to 160 kPa	4 bar	6.4 bar / 640 kPa
	A1N	0 to 2.5 bar / 0 to 250 kPa	6.7 bar	10 bar / 1 MPa
	A1Q	0 to 4 bar / 0 to 400 kPa	10.7 bar	16 bar / 1.6 MPa
	A1R	0 to 6 bar / 0 to 600 kPa	16 bar	24 bar / 2.4 MPa
	A1S	0 to 10 bar / 0 to 1 MPa	25 bar	40 bar / 4 MPa
	A1T	0 to 16 bar / 0 to 1.6 MPa	25 bar	64 bar / 6.4 MPa
	A1W	0 to 25 bar / 0 to 2.5 MPa	25 bar	100 bar / 10 MPa
	A1X	0 to 40 bar / 0 to 4 MPa	60 bar	160 bar / 16 MPa
	A1Z	0 to 60 bar / 0 to 6 MPa	60 bar	240 bar / 24 MPa
	A70	0 to 100 bar / 0 to 10 MPa	100 bar	400 bar / 40 MPa
	A71	0 to 160 bar / 0 to 16 MPa	160 bar	600 bar / 60 MPa
	A73	0 to 250 bar / 0 to 25 MPa	250 bar	600 bar / 60 MPa
	A74	0 to 400 bar / 0 to 40 MPa	400 bar	600 bar / 60 MPa
	Q4H	0 to 15 psi	40 psi	60 psi
	Q4K	0 to 30 psi	100 psi	150 psi
	Q4N	0 to 50 psi	160 psi	240 psi
	Q4R	0 to 150 psi	400 psi	600 psi
	Q4S	0 to 300 psi	400 psi	1500 psi
	Q4T	0 to 500 psi	1000 psi	2400 psi
	Q4V	0 to 1000 psi	1000 psi	3600 psi
	Q70	0 to 1500 psi	1500 psi	6000 psi
	Q73	0 to 3000 psi	3000 psi	9000 psi
	Q74	0 to 6000 psi	6000 psi	9000 psi
PMP131			Order code	

→ For continuation of ordering information of PMP131, see the following page.

PMP131 (continued)

50				Sensor range; MWP; OPL:		
				Sensor range	MWP (maximum working pressure)	OPL (over pressure limit)
				Sensors for absolute pressure		
				A2G	0 to 1 bar / 0 to 100 kPa	2.7 bar / 400 kPa
				A2H	0 to 1.6 bar / 0 to 160 kPa	4 bar / 640 kPa
				A2N	0 to 2.5 bar / 0 to 250 kPa	6.7 bar / 1 MPa
				A2Q	0 to 4 bar / 0 to 400 kPa	10.7 bar / 1.6 MPa
				A2R	0 to 6 bar / 0 to 600 kPa	16 bar / 2.4 MPa
				A2S	0 to 10 bar / 0 to 1 MPa	25 bar / 4 MPa
				A2T	0 to 16 bar / 0 to 1.6 MPa	25 bar / 64 MPa
				A2W	0 to 25 bar / 0 to 2.5 MPa	100 bar / 10 MPa
				A2X	0 to 40 bar / 0 to 4 MPa	160 bar / 16 MPa
				A2Z	0 to 60 bar / 0 to 6 MPa	240 bar / 24 MPa
				B70	0 to 100 bar / 0 to 10 MPa	400 bar / 40 MPa
				B71	0 to 160 bar / 0 to 16 MPa	600 bar / 60 MPa
				B73	0 to 250 bar / 0 to 25 MPa	600 bar / 60 MPa
				B74	0 to 400 bar / 0 to 40 MPa	600 bar / 60 MPa
				R4H	0 to 15 psi	60 psi
				R4K	0 to 30 psi	150 psi
				R4N	0 to 50 psi	240 psi
				R4R	0 to 150 psi	600 psi
				R4S	0 to 300 psi	1500 psi
				R4T	0 to 500 psi	2400 psi
				R4V	0 to 1000 psi	3600 psi
				R70	0 to 1500 psi	6000 psi
				R73	0 to 3000 psi	9000 psi
				R74	0 to 6000 psi	9000 psi
995				Marking		
				1	Tagging (TAG), see additional spec.	
PMP131				Complete order code		

PMP135

This overview does not mark options which are mutually exclusive.

10	Electrical connection:			
	A1	Plug ISO 4400, M 16, IP 65/NEMA 4X		
	A2	Plug ISO 4400, ½ NPT, IP 65/NEMA 4X		
	A3	5 m cable, IP 68/NEMA 6P		
	A4	Plug M 12, IP 65/NEMA 4X		
20	Process connection:			
	F	Clamp ISO 2852, DN 22 (¾"), AISI 316L, 3A, DIN 32676 DN 20, EHEDG		
	G	Tri-Clamp ISO 2852, DN 25 to 38 (1" to 1½"), AISI 316L, 3A, DIN 32676 DN 25 to 40, EHEDG		
	H	Tri-Clamp ISO 2852, DN 40 to 51 (2"), AISI 316L, 3A, DIN 32676 DN 50, EHEDG		
	M	Thread ISO 228, G 1, with metallic sealing taper, AISI 316L, flush-mounted, adapter 52005087		
	N	Thread ISO 228, G 1, with sealing surface for flush-mounted installation, AISI 316L, adapter 52001051		
	S	SMS 1½", PN 25, AISI 316L, 3A, EHEDG		
30	Output:			
	0	Analog 4 to 20 mA, SIL		
	D	Analog 4 to 20 mA, SIL, ATEX II 1/2 G Ex ib IIC T6		
	1	Analog 4 to 20 mA, SIL, ATEX II 2 G Ex ib IIC T6		
	5	Analog 4 to 20 mA, SIL, ATEX II 3 G Ex nA II T6		
	2	Switch output PNP, 3-wire		
	3	Switch output PNP, ATEX II 3 G Ex nA II T6		
40	Additional options:			
	1	Basic version		
	C	EN10204-3.1 material (wetted parts) inspection certificate		
	D	Final inspection report + EN10204-3.1 material (wetted parts) inspection certificate		
	2	Final inspection report		
50	Sensor range; MWP; OPL:			
		Sensor range	MWP (maximum working pressure)	OPL (over pressure limit)
		Sensors for gauge pressure		
	A1G	0 to 1 bar / 0 to 100 kPa	2.7 bar	4 bar / 400 kPa
	A1H	0 to 1.6 bar / 0 to 160 kPa	4 bar	6.4 bar / 640 kPa
	A1N	0 to 2.5 bar / 0 to 250 kPa	6.7 bar	10 bar / 1 MPa
	A1Q	0 to 4 bar / 0 to 400 kPa	10.7 bar	16 bar / 1.6 MPa
	A1R	0 to 6 bar / 0 to 600 kPa	16 bar	24 bar / 2.4 MPa
	A1S	0 to 10 bar / 0 to 1 MPa	25 bar	40 bar / 4 MPa
	A1T	0 to 16 bar / 0 to 1.6 MPa	25 bar	64 bar / 6.4 MPa
	A1W	0 to 25 bar / 0 to 2.5 MPa	25 bar	100 bar / 10 MPa
	A1X	0 to 40 bar / 0 to 4 MPa	60 bar	160 bar / 16 MPa
	Q4H	0 to 15 psi	40 psi	60 psi
	Q4K	0 to 30 psi	100 psi	150 psi
	Q4N	0 to 50 psi	160 psi	240 psi
	Q4R	0 to 150 psi	400 psi	600 psi
	Q4S	0 to 300 psi	400 psi	1500 psi
	Q4T	0 to 500 psi	1000 psi	2400 psi
		Sensors for absolute pressure		
	A2G	0 to 1 bar / 0 to 100 kPa	2.7 bar	4 bar / 400 kPa
	A2H	0 to 1.6 bar / 0 to 160 kPa	4 bar	6.4 bar / 640 kPa
	A2N	0 to 2.5 bar / 0 to 250 kPa	6.7 bar	10 bar / 1 MPa
	A2Q	0 to 4 bar / 0 to 400 kPa	10.7 bar	16 bar / 1.6 MPa
	A2R	0 to 6 bar / 0 to 600 kPa	16 bar	24 bar / 2.4 MPa
	A2S	0 to 10 bar / 0 to 1 MPa	25 bar	40 bar / 4 MPa
	A2T	0 to 16 bar / 0 to 1.6 MPa	25 bar	64 bar / 6.4 MPa
	A2W	0 to 25 bar / 0 to 2.5 MPa	25 bar	100 bar / 10 MPa
	A2X	0 to 40 bar / 0 to 4 MPa	60 bar	160 bar / 16 MPa
	R4H	0 to 15 psi	40 psi	60 psi
	R4K	0 to 30 psi	100 psi	150 psi
	R4N	0 to 50 psi	160 psi	240 psi
	R4R	0 to 150 psi	400 psi	600 psi
	R4S	0 to 300 psi	400 psi	1500 psi
	R4T	0 to 500 psi	1000 psi	2400 psi
995	Marking			
	1	Tagging (TAG), see additional spec.		
PMP135				Complete order code

Accessories

Welding neck with sealing taper

- Welding neck for flush-mounted installation of the process connection G1 A with metallic sealing taper (PMP135, version M)
Material: AISI 316L (1.4435)
Order number: 52005087
- with inspection certificate 3.1
Order number: 52010171

- Pressure sensor dummy for welding the welding neck without any problems with order number 52005087 or 52010171
Material: CuZn
Order number: 52005272

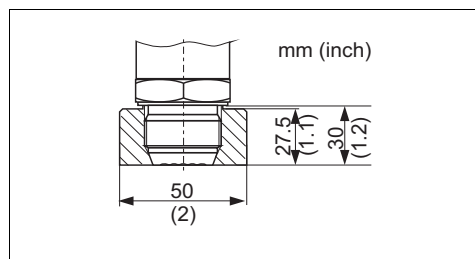

P01-PMP135xx-00-xx-00-xx-005

Welding neck with sealing surface

- Welding neck for flush-mounted installation of the process connection G1 A with sealing surface (PMP135, version N)
Material: AISI 316L (1.4435)
Gasket (enclosed): silicone O-ring
Order number: 52001051
- Optional with inspection certificate 3.1
Order number: 52011896

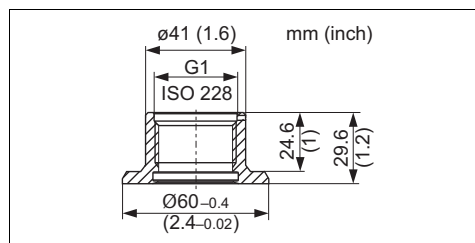

P01-PMP135xx-00-xx-00-xx-005

Plug-in jack

- Plug-in jack M 12x1, straight
Self-made connection to M 12x1 housing plug
Material: Handle body PA; Coupling nut CuZn, nickel-plated, degree of protection (inserted): IP 67
Order number: 52006263

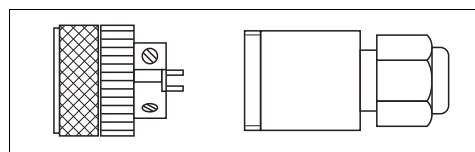

P01-PMP135xx-00-xx-00-xx-005

Connecting cable

- Cable, 4 x 0.34 mm² (AWG 21) with M12 socket, elbowed, screw plug, length 5 m (16 ft), sprayed cable
Materials: Body PUR
Coupling nut: Cu Zn/Ni, brass, nickered
Cable: PVC
Protection: IP 67 (fully locked)
order number: 52010285

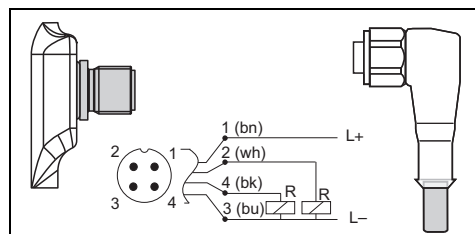

P01-PMx13xxx-07-xx-xx-xx-000

Plug-on display PHX20/PHX21

- Plug-on display for electrical connections
 - PMC131 version A1, A2, B1, C1, C2
 - PMP131/135 version A1, A2.
 4-digit red LED display for looping into 4 to 20 mA circuit via elbow plug ISO4400, rotatable in 90° steps, programmable via 2 keys
Display range: -1999 to +9999
Degree of protection: IP 65
Material: Housing Pa6 GF30, front screen PMMA
Voltage drop: ≤5 V (corresponds to max. 250 Ω load)
Approval for PHX21: ATEX II 2G
Order number PHX20: 52022914
Order number PHX21: 52022915

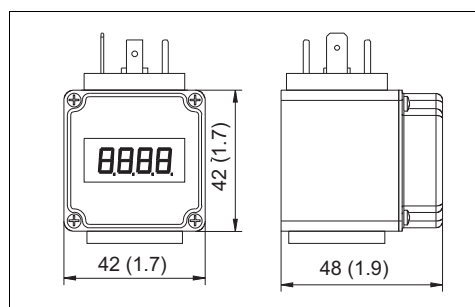

P01-PHX2xxx-06-xx-xx-xx-000

Documentation

Field of Activities	<ul style="list-style-type: none"> ■ Pressure measurement, powerful measuring devices for process pressure, differential pressure, level and flow: FA00004P/00/EN
Technical Information	<ul style="list-style-type: none"> ■ EMC test procedures: TI00241F/00/EN
Operating Instructions	<ul style="list-style-type: none"> ■ Cerabar T PMC131: KA00085P/00/A3 ■ Cerabar T PMP131: KA00103P/00/A3 ■ Cerabar T PMP135: KA00198P/00/A3
Functional Safety Manual (SIL)	<ul style="list-style-type: none"> ■ Cerabar T PMP131, PMP135: SD00160P/00/EN

Safety Instructions

Certificate/Type of protection	Device	Documentation	Version in the order code
ATEX II 3 G Ex nA II T4 ¹⁾	PMC131	– XA00191P	B1, B3, B5
ATEX II 1/2 G Ex ib IIC T6 ATEX II 2 G Ex ib IIC T6 ATEX II 3 G Ex nA II T6 ¹⁾	PMP131, PMP135	– XA00142P – XA00191P	D 1 3, 5

- 1) In the event of applications in a Zone 2 explosive atmosphere (Ex nA explosion protection) protect the housing from impact.

Instruments International

Endress+Hauser
Instruments International AG
Kaegenstrasse 2
4153 Reinach
Switzerland

Tel.+41 61 715 81 00
Fax+41 61 715 25 00
www.endress.com
info@ii.endress.com

Endress+Hauser 
People for Process Automation

