

# Technical Information

## Deltapilot M

### FMB50, FMB51, FMB52, FMB53

Hydrostatic level measurement

Pressure sensor with the CONTITE™ measuring cell  
Condensate-resistant



#### Application

The device is used for the following measuring tasks:

- Hydrostatic pressure measurement in liquids and paste-like media in all areas of process engineering, process measuring technology, pharmaceuticals and the food industry
- Level, volume or mass measurements in liquids

#### Your benefits

- Very good reproducibility and long-term stability
- Maximum plant safety provided by one-of-a-kind, condensate-proofed CONTITE measuring cell
- High reference accuracy:  $\pm 0.2\%$   
optionally  $\pm 0.1\%$
- Turn down 100:1
- Standardized platform for differential pressure, hydrostatics, and pressure (Deltabar S – Deltapilot S – Cerabar S)
- Simple, fast commissioning through a user interface designed for real-world applications
- Used for process pressure monitoring up to SIL2, certified to IEC 61508 Edition 2.0 and IEC 61511 by TÜV NORD
- Usage in drinking water: KTW, NSF

## Table of contents





<b>Document information</b> .....	<b>4</b>	Total error .....	27
Symbols used .....	4	Warm-up period .....	27
Terms and abbreviations .....	6		
<b>Function and system design</b> .....	<b>7</b>	<b>Installation</b> .....	<b>28</b>
Device selection .....	7	General installation instructions .....	28
Measuring principle .....	9	FMB50 .....	28
Level measurement in closed tanks with pressure overlay ..	10	FMB51/FMB52/FMB53 .....	28
Density measurement .....	11	Supplementary installation instructions .....	29
Level measurement with automatic density correction (with media changing in the tank) .....	11	Wall and pipe mounting .....	29
Electrical differential pressure measurement with gauge pressure sensors .....	12	"Separate housing" version .....	30
Communication and data processing .....	12	Oxygen applications .....	31
		PWIS cleaning .....	31
		Applications with hydrogen .....	31
		Special measuring cells for acids, alkalis or sea water (not FMB50) .....	31
<b>Input</b> .....	<b>13</b>	<b>Environment</b> .....	<b>32</b>
Measured variable .....	13	Ambient temperature limits .....	32
Measuring range .....	13	Storage temperature range .....	32
		Climate class .....	32
		Degree of protection .....	32
		Vibration resistance .....	32
		Electromagnetic compatibility .....	32
<b>Output</b> .....	<b>14</b>	<b>Process</b> .....	<b>33</b>
Output signal .....	14	Process temperature range .....	33
Signal range – 4 to 20 mA HART .....	14	Lateral load FMB51 (static) .....	33
Signal on alarm .....	14	Pressure specifications .....	33
Load - 4 to 20 mA HART .....	14		
Dead time, time constant .....	15	<b>Mechanical construction</b> .....	<b>34</b>
Dynamic behavior: current output .....	15	Device height .....	34
Dynamic behavior: HART .....	15	F31 housing, aluminum .....	34
Dynamic behavior: PROFIBUS PA .....	16	F15 housing, stainless steel (hygienic) .....	35
Dynamic behavior: FOUNDATION Fieldbus .....	16	Process connections FMB50, FMB51, FMB52 .....	35
Damping .....	16	Process connections FMB50, FMB51, FMB52 .....	36
Firmware version .....	16	Process connections FMB50, FMB51, FMB52 - continued ..	37
Galvanic isolation .....	17	Process connections FMB50, FMB51, FMB52 - continued ..	38
Protocol-specific data .....	17	Process connections FMB50 - continued .....	39
		Process connections FMB50 - continued .....	40
		Process connections FMB51 (rod version) .....	42
		Process connections FMB52 (cable version) .....	44
		Dimensions of FMB53 with F31 housing, suspension clamp and mounting bracket .....	46
		Dimensions of FMB53 with F15 housing, suspension clamp and mounting bracket .....	47
		Wall and pipe mounting with "Separate housing" version ...	48
		Materials not in contact with process .....	51
		Materials in contact with the process .....	54
<b>Power supply</b> .....	<b>21</b>	<b>Operability</b> .....	<b>57</b>
Terminal assignment .....	21	Operating concept .....	57
Supply voltage .....	21	Onsite operation .....	57
Current consumption .....	22	Operating languages .....	59
Electrical connection .....	22	Remote operation .....	59
Terminals .....	22	System integration .....	60
Cable entry .....	22		
Connector .....	23		
Cable specification .....	24		
Start-up current HART .....	24		
Residual ripple .....	24		
Influence of power supply .....	24		
Overvoltage protection (optional) .....	25		
<b>Performance characteristics</b> .....	<b>26</b>		
Reference operating conditions .....	26		
Influence of orientation .....	26		
Calibration position .....	26		
Resolution .....	26		
Reference accuracy .....	26		
Thermal change in the zero output and the output span ...	27		
Total performance .....	27		
Long-term stability .....	27		

<b>Certificates and approvals</b> .....	<b>61</b>
CE mark .....	61
C-tick symbol .....	61
Ex approvals .....	61
Suitability for hygienic processes .....	61
Pharma (CoC) (FMB50 only) .....	61
Functional safety SIL .....	61
Overfill protection .....	62
AD2000 .....	62
Pressure Equipment Directive (PED) .....	62
Marine approval .....	62
Other standards and guidelines .....	62
Drinking water approval .....	62
Classification of process sealing between electrical systems and (flammable or combustible) process fluids in accordance with ANSI/ISA 12.27.01 .....	62
Inspection certificate .....	62
Calibration; unit .....	63
Calibration .....	63
Service .....	63
<b>Ordering information</b> .....	<b>64</b>
Configuration data sheet .....	64
<b>Accessories</b> .....	<b>66</b>
Suspension clamp (FMB53 only) .....	66
Extension cable shortening kit (FMB53 only) .....	66
M12 connector .....	66
Welding necks and Weld-in tool flanges .....	66
Adapter Uni for FMB50 .....	67
<b>Documentation</b> .....	<b>68</b>
Technical Information .....	68
Operating Instructions .....	68
Brief Operating Instructions .....	68
Functional safety manual (SIL) .....	68
Safety Instructions .....	68
Installation/Control Drawings .....	69
Combination certificate .....	69
Overfill protection .....	69
<b>Registered trademarks</b> .....	<b>70</b>
HART® .....	70
PROFIBUS® .....	70
FOUNDATION™ Fieldbus .....	70







## Document information

### Symbols used





### Safety symbols

Symbol	Meaning
 A0011189-EN	<b>DANGER!</b> This symbol alerts you to a dangerous situation. Failure to avoid this situation will result in serious or fatal injury.
 A0011190-EN	<b>WARNING!</b> This symbol alerts you to a dangerous situation. Failure to avoid this situation can result in serious or fatal injury.
 A0011191-EN	<b>CAUTION!</b> This symbol alerts you to a dangerous situation. Failure to avoid this situation can result in minor or medium injury.
 A0011192-EN	<b>NOTE!</b> This symbol contains information on procedures and other facts which do not result in personal injury.









### Electrical symbols

Symbol	Meaning
 A0018335	<b>Direct current</b> A terminal at which DC voltage is present or through which direct current flows.
 A0018336	<b>Alternating current</b> A terminal at which alternating voltage is present or through which alternating current flows.
 A0018337	<b>Direct current and alternating current</b> <ul style="list-style-type: none"> <li>▪ A terminal at which alternating voltage or DC voltage is present.</li> <li>▪ A terminal through which alternating current or direct current flows.</li> </ul>
 A0018338	<b>Ground connection</b> A grounded terminal which, as far as the operator is concerned, is grounded via a grounding system.
 A0018339	<b>Protective ground connection</b> A terminal which must be connected to ground prior to establishing any other connections.
 A0011201	<b>Equipotential connection</b> A connection that has to be connected to the plant grounding system: This may be a potential equalization line or a star grounding system depending on national or company codes of practice.



### Tool symbols

Symbol	Meaning
 A0011219	Phillips head screwdriver
 A0011220	Flat-blade screwdriver
 A0013442	Torx screwdriver
 A0011222	Hexagon wrench
 A0011221	Allen screw

**Symbols for certain types of information**

Symbol	Meaning
 A0011182	<b>Permitted</b> Indicates procedures, processes or actions that are permitted.
 A0011183	<b>Preferred</b> Indicates procedures, processes or actions that are preferred.
 A0011184	<b>Forbidden</b> Indicates procedures, processes or actions that are forbidden.
 A0011193	<b>Tip</b> Indicates additional information.
 A0015483	<b>Reference to documentation</b> Refers to the corresponding device documentation.
 A0015484	<b>Reference to page</b> Refers to the corresponding page number.
 A0015486	<b>Reference to graphics</b> Refers to the corresponding graphic number and page number.
1. , 2. , ...	Series of steps
 A0015488	<b>Help in the event of a problem</b>

**Symbols in graphics**



Symbol	Meaning
1, 2, 3, 4 etc.	Numbering for main items
1. , 2. , ...	Series of steps
A, B, C, D etc.	Views
A-A, B-B, etc.	Sections
 A0011187	<b>Hazardous area</b> Indicates the hazardous area.
 A0011188	Safe area (non-hazardous area) Indicates the non-hazardous area.

Terms and abbreviations

Term/abbreviation	Explanation
MWP	The MWP (maximum working pressure) for the individual sensors depends on the lowest-rated element, with regard to pressure, of the selected components, i.e. the process connection has to be taken into consideration in addition to the measuring cell. Pay attention to the pressure-temperature dependence also. For the relevant standards and additional notes, see section " → 33".
OPL	The OPL (over pressure limit = sensor overload limit) for the sensor depends on the lowest-rated element, with regard to pressure, of the selected components, i.e. the process connection has to be taken into consideration in addition to the measuring cell. Pay attention to the pressure-temperature dependence also. For the relevant standards and additional notes, see section " → 33".
LRL	Lower range limit
URL	Upper range limit
LRV	Lower range value
URV	Upper range value
<b>TD</b>	<b>Turn down</b>
<p>Case 1:</p> <ul style="list-style-type: none"> <li>Lower range value (LRV) <math>\leq</math> Upper range value (URV)</li> </ul> <p>Example:</p> <ul style="list-style-type: none"> <li>Lower range value (LRV) = 0 mbar</li> <li>Upper range value (URV) = 40 mbar (0.6 psi)</li> <li>Nominal value (URL) = 400 mbar (6 psi)</li> </ul> <p>Turn down:</p> <ul style="list-style-type: none"> <li>TD = URL /  URV  = 10:1</li> </ul> <p>Set span:</p> <ul style="list-style-type: none"> <li>URV - LRV = 40 mbar (0.6 psi)</li> <li>This span is based on the zero point.</li> </ul>	<p style="text-align: right; font-size: small;">A0019783</p> <p>Example: 400 mbar (6 psi) measuring cell</p>
<p>Case 2:</p> <ul style="list-style-type: none"> <li>Lower range value (LRV) <math>\geq</math> Upper range value (URV)</li> </ul> <p>Example:</p> <ul style="list-style-type: none"> <li>Lower range value (LRV) = -200 mbar (3 psi)</li> <li>Upper range value (URV) = 0 bar</li> <li>Nominal value (URL) = 400 mbar (6 psi)</li> </ul> <p>Turn down:</p> <ul style="list-style-type: none"> <li>TD = URL /  (LRV)  = 2:1</li> </ul> <p>Set span:</p> <ul style="list-style-type: none"> <li>URV - LRV = 200 mbar (3 psi)</li> <li>This span is based on the zero point.</li> </ul>	<p style="text-align: right; font-size: small;">A0016451</p> <p>Example: 400 mbar (6 psi) measuring cell</p> <ol style="list-style-type: none"> <li>1 Set span</li> <li>2 Span based on zero point</li> <li>3 Nominal value <math>\hat{=}</math> upper range limit (URL)</li> <li>4 Nominal measuring range</li> <li>5 Sensor measuring range</li> </ol>

## Function and system design

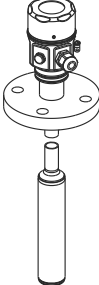
### Device selection

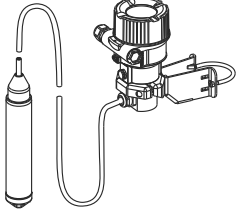
Deltapilot M – Product family	FMB50  <small>A0023537</small> <b>Compact version</b>	FMB51  <small>A0023538</small> <b>Rod version</b>	FMB52  <small>A0023539</small> <b>Cable version</b>	FMB53  <small>A0023540</small> <b>Cable version with Mounting bracket</b>
Field of application	– Level measurement – Pressure measurement			
Industries	Food, pharmaceuticals, chemicals, power plants, automotive, etc.			Environment (freshwater and wastewater)
Process connections	– Thread – Flanges – Flush-mounted hygienic connections	– Thread – Flanges	– Thread – Flanges	Suspension clamp
Measuring ranges	From -0.1 to +0.1 (-1.5 to +1.5 psi) bar to -1 bar to +10 bar (-15 to 150 psi)			
OPL	Max. 40 bar (600 psi)			
Process temperature range	-10 to +100 °C (+14 to +212°F) (+135 °C (275°F) for 30 minutes maximum)	-10 to +85 °C (+14 to +185°F)	With PE cable (unmoved): -10 to +70 °C (+14 to +158°F) With FEP cable (unmoved): -10 to +80 °C (+14 to +176°F)	
Ambient temperature range	<ul style="list-style-type: none"> <li>▪ Without LCD display: -40 to +85 °C (-40 to +185°F)</li> <li>▪ With LCD display: -20 to +70 °C (-4 to +158°F) (extended temperature application range -40 to 85 °C (-40 to +158°F) with restrictions in optical properties such as display speed and contrast)</li> <li>▪ Separate housing: -20 to +60 °C (-4 to +140°F)</li> </ul>			
Reference accuracy	0.2 % (option 0.1 %) depends on the measuring range → 26			
Supply voltage	– 11.5 to 45 V DC (versions with plug-in connection 35 V DC) – For intrinsically safe device versions: 11.5 to 30 V DC			
Output	4 to 20 mA with superimposed HART protocol, PROFIBUS PA or FOUNDATION Fieldbus			
Options	<ul style="list-style-type: none"> <li>– Gold/rhodium-coated process isolating diaphragm</li> <li>– 3.1 inspection certificate</li> <li>– 3A approval and EHEDG approval for FMB50</li> <li>– Specific firmware versions</li> <li>– Initial device settings can be ordered</li> <li>– Separate housing</li> </ul>			
Specialties	<ul style="list-style-type: none"> <li>– Absolute resistance to condensate thanks to hermetically sealed CONTITE™ cell</li> <li>– Maximum flexibility thanks to modular design</li> <li>– Special cleaning of the transmitter to remove paint-wetting substances, for use in paint shops</li> </ul>			

**FMB50, FMB51, FMB52 universal application**

- Modular probe program to ensure optimum process adaptation
- FMB50 compact version: installation in the tank from below or from the side
- FMB51, FMB52 rod and cable extension: installation from above, i.e. easy to retrofit ground tanks, no additional opening in the vessel floor

**FMB50 optimized for hygienic applications**

- All typical flush-mounted process connections can be supplied
- Welding flanges
- Stainless steel housing
- All the sanitary process connections are gap-free and can be cleaned so that the unit is free of residue, e.g. CIP cleaning
- USDA/H1-approved transfer liquid as per FDA Directive
- 3A approval or EHEDG approvals

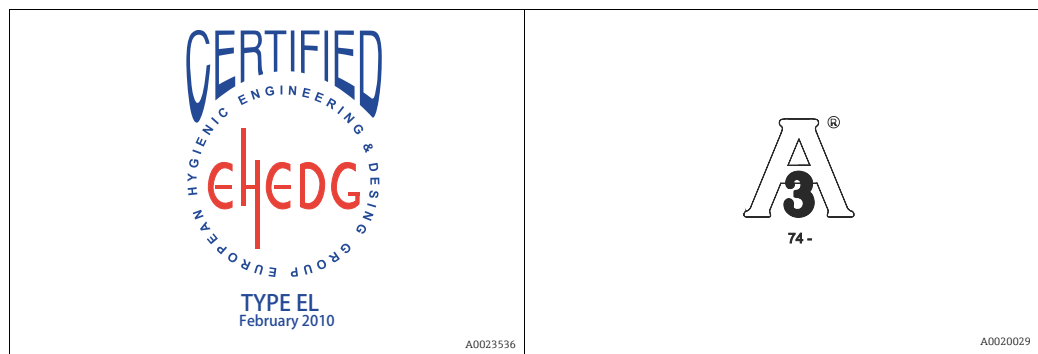
**FMB53 for level measurement in water and wastewater**

- The housing with the electronic insert is mounted outside shafts and vessels in such a way that it is protected from flooding. The extension cable is secured with a suspension clamp.
- The measuring cell tube made of stainless steel (AISI 316L) and the Alloy process isolating diaphragm allow use in aggressive media such as wastewater for example.
- Extension cable up to 400 m (1312 ft) in length (up to 100 m (328 ft) in Ex-areas) without strain relief.
- Special measuring cell with gold/rhodium coating for applications in which severe hydrogen formation can occur (e.g. digested sludge); → 31.
- Special measuring cell with gold/platinum coating for acids, alkalis or sea water; → 31.



## Measuring principle

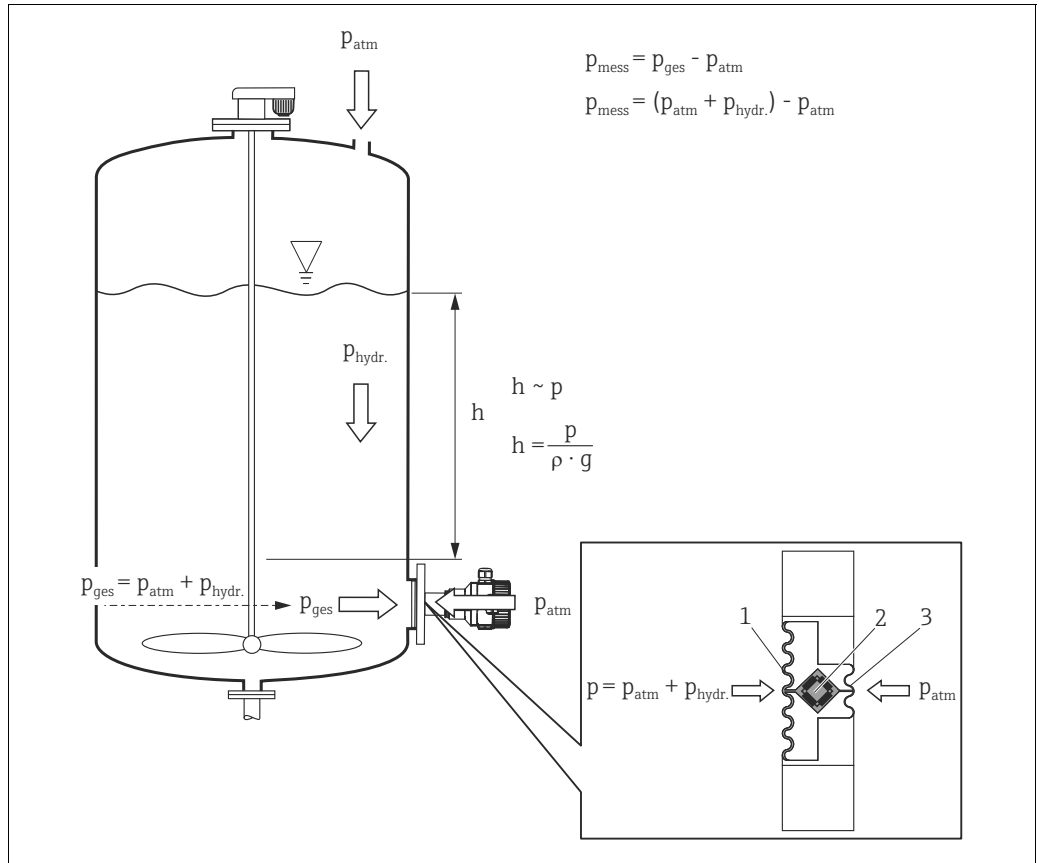

Deltapilot M hydrostatic level measurement and measuring principle

- 1 Rear isolating membrane of the CONTITE™ measuring cell
- 2 Measuring element
- 3 Process isolating diaphragm
- $g$  Gravitational acceleration
- $h$  Level height
- $p_{\text{ges}}$  Total pressure = hydrostatic pressure + atmospheric pressure
- $p_{\text{atm}}$  Atmospheric pressure
- $p_{\text{hydr.}}$  Hydrostatic pressure
- $p_{\text{mess}}$  Measured pressure in the measuring cell = hydrostatic pressure
- $\rho$  Density of the medium

Due to its weight, a liquid column creates hydrostatic pressure. If the density is constant, the hydrostatic pressure depends solely on the height  $h$  of the liquid column.

The CONTITE™ measuring cell, which works on the principle of the gauge pressure sensor, constitutes the core of Deltapilot M. In contrast to conventional gauge pressure sensors, the precision measuring element (2) in the CONTITE™ measuring cell is absolutely protected, situated between the process isolating diaphragm (3) and the rear isolating membrane (1). Thanks to this hermetic sealing of the measuring element, the CONTITE™ measuring cell is absolutely insensitive to condensate/condensation and aggressive gases. The pressure applied is transferred from the process isolating diaphragm to the measuring element by means of an oil without any loss in pressure. Any measured errors due to fluctuations in temperature are compensated for in the electronics unit by means of the sensor temperature.

A linearization function with max. 32 points, based on a table entered either manually or semi-automatically, can be activated locally or remotely. This function facilitates measurement in engineering units, and provides a linear output signal for spherical and horizontal cylindrical vessels, and vessels with a conical outlet.

### Level measurement in closed tanks with pressure overlay

You can determine the differential pressure in tanks with pressure overlay using two Deltapilot M. The pressure measured values of the two probes are sent to a signal processing unit such as Endress+Hauser RMA or a PLC. The signal processing unit or PLC determines the difference in pressure and uses this to calculate the level and the density where necessary.

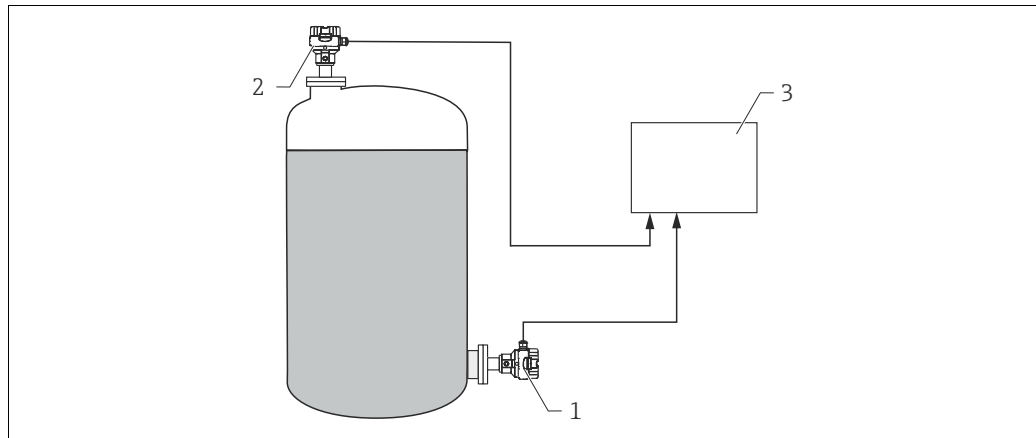

A0023542

Level measurement in a closed tank with pressure overlay

- 1 Deltapilot 1 measures the total pressure (hydrostatic pressure and top pressure)
- 2 Deltapilot 2 measures the top pressure
- 3 Signal processing unit determines the difference in pressure and uses this to calculate the level

#### NOTICE

##### Measured errors can occur.

Large measured errors can occur if the ratio of the level to the top pressure is  $>1:6$ . This does not affect reproducibility.

- ▶ When selecting the measuring cell, make sure you select measuring ranges that are sufficiently wide ( $\rightarrow$  see example).

Example:

- Max. hydrostatic pressure = 600 mbar (9 psi)
- Max. top pressure (Deltapilot 2) = 300 mbar (4.5 psi)
- Max. total pressure, measured with Deltapilot 1 = 300 mbar (4.5 psi) + 600 mbar (9 psi) = 900 mbar (13.5 psi)  $\Rightarrow$  measuring cell to be selected: 0 to 1200 mbar (0 to 18 psi)
- Max. pressure, measured with Deltapilot 2: 300 mbar (4.5 psi)  $\Rightarrow$  measuring cell to be selected: 0 to 400 mbar (6 psi)

#### NOTICE

##### Possibility of probe 2 flooding during differential pressure measurement.

Measured errors can occur.

- ▶ When installing, make sure that probe 2 cannot be flooded.

**Density measurement**

You can measure the density in tanks with pressure overlay using two Deltapilot M and a signal processing unit or a PLC. The signal processing unit or the PLC calculates the density from the known distance between the two Deltapilot M devices  $\Delta h$  and the two measured values  $p_1$  and  $p_2$ .

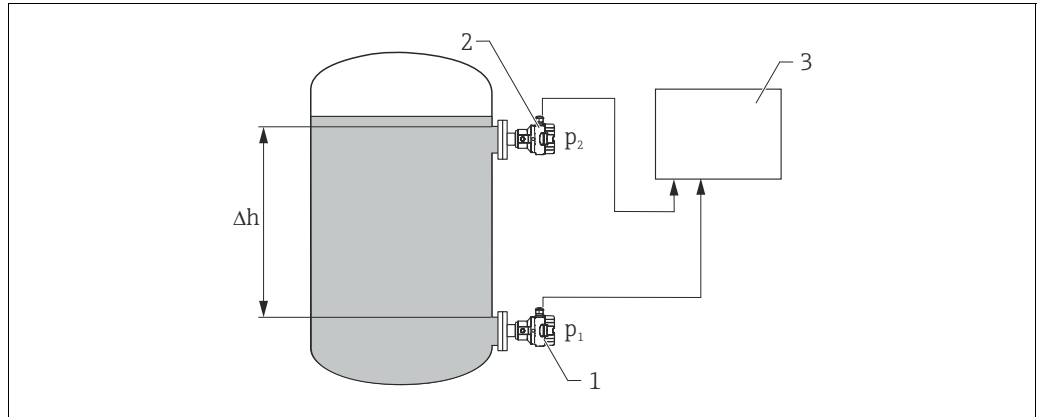

A0023544

Level measurement in a closed tank with pressure overlay

- 1 Deltapilot 1 determines pressure measured value  $p_1$
- 2 Deltapilot 2 determines pressure measured value  $p_2$
- 3 Signal processing unit determines the density from the two measured values  $p_1$  and  $p_2$  and the distance  $\Delta h$

**Level measurement with automatic density correction (with media changing in the tank)**

Level measurement with automatic density correction is possible in conjunction with a limit switch such as Liquiphant and a PLC. The limit switch always switches at the same level. In the switch point, the signal processing unit determines the corrected density from the pressure of the Deltapilot M currently measured and the known distance between Deltapilot M and the limit switch. The signal processing unit then calculates the level from the new density and the measured pressure of the Deltapilot M.

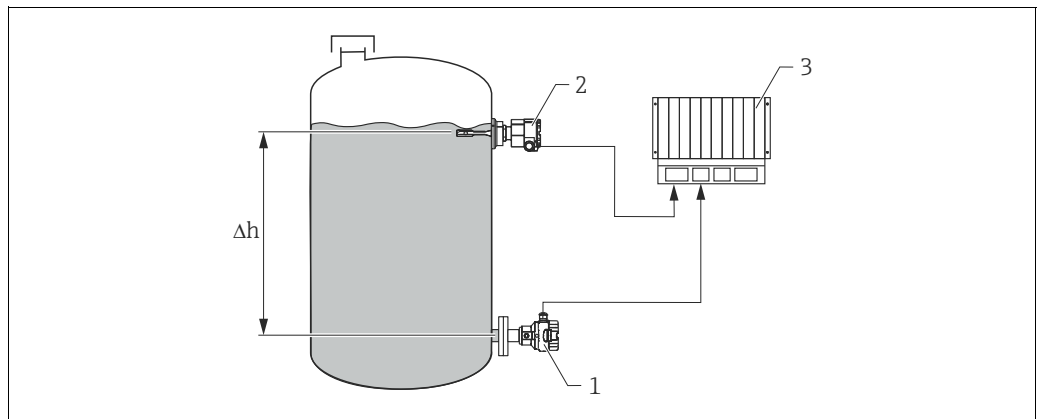

A0023546

Level measurement with automatic density correction

- 1 Deltapilot M
- 2 Liquiphant
- 3 PLC

## Electrical differential pressure measurement with gauge pressure sensors

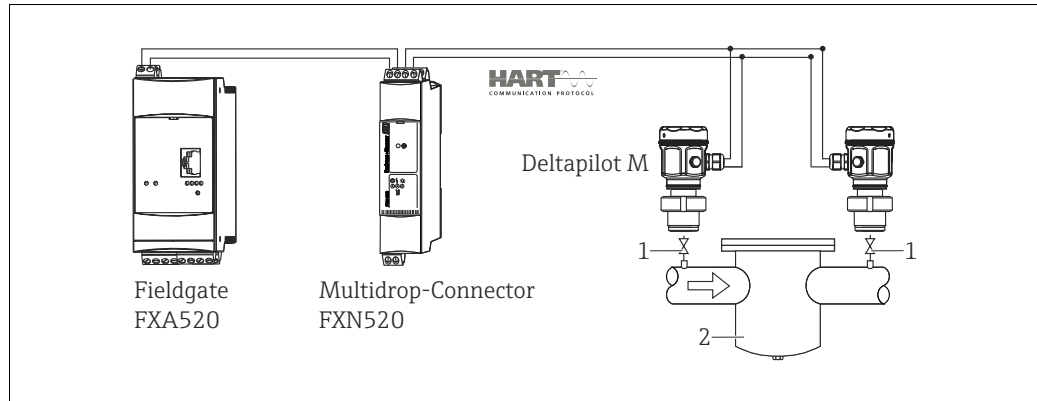

- 1 Shut-off valves  
2 e.g. filter

In the example given, two Deltapilot M devices (each with a gauge pressure sensor) are interconnected. The pressure difference can thus be measured using two independent Deltapilot M devices.

### **▲ WARNING**

#### **Risk of explosion!**

- ▶ If using intrinsically safe devices, strict compliance with the rules for interconnecting intrinsically safe circuits as stipulated in IEC60079-14 (proof of intrinsic safety) is mandatory.

## Communication and data processing

- 4 to 20 mA with HART communication protocol
  - PROFIBUS PA
    - The Endress+Hauser devices meet the requirements of the FISCO model.
    - Due to the low current consumption of  $11 \text{ mA} \pm 1 \text{ mA}$ , the following number of devices can be operated on one bus segment if installing as per FISCO:
      - up to 8 Deltapilot M for Ex ia, CSA IS and FM IS applications
      - up to 31 Deltapilot M for all other applications, e.g. in non-hazardous areas, Ex nA, etc.
- Further information on PROFIBUS PA can be found in Operating Instructions BA00034S "PROFIBUS DP/PA: Guidelines for planning and commissioning" and in the PNO Guideline.
- FOUNDATION Fieldbus
    - The Endress+Hauser devices meet the requirements of the FISCO model.
    - Due to the low current consumption of  $16 \text{ mA} \pm 1 \text{ mA}$ , the following number of devices can be operated on one bus segment if installing as per FISCO:
      - up to 6 Deltapilot M for Ex ia, CSA IS and FM IS applications
      - up to 22 Deltapilot M for all other applications, e.g. in non-hazardous areas, Ex nA, etc.
- Further information on FOUNDATION Fieldbus, such as requirements for bus system components can be found in Operating Instructions BA00013S "FOUNDATION Fieldbus Overview".

## Input

**Measured variable**                      Hydrostatic pressure

### Measuring range

Nominal value	Range limit		Smallest calibratable span (preset at the factory) <sup>1)</sup>	MWP	OPL	Vacuum resistance <sup>2)</sup>  Synthetic oil/ Inert oil [bar <sub>abs</sub> (psi <sub>abs</sub> )]	Option <sup>3)</sup>
	lower (LRL) <sup>4)</sup>	upper (URL)					
[bar (psi)]	[bar (psi)]	[bar (psi)]	[bar (psi)]	[bar (psi)]	[bar (psi)]	[bar <sub>abs</sub> (psi <sub>abs</sub> )]	
0.1 (1.5)	-0.1 (-1.5)	+0.1 (+1.5)	0.01 (0.15)	2.7 (40.5)	4 (60)	0.01/0.04 (0.145/0.6)	1C
0.4 (6)	-0.4 (-6)	+0.4 (+6)	0.02 (0.3)	5.3 (79.5)	8 (120)		1F
1.2 (18)	-1 (-15)	+1.2 (+18)	0.06 (1)	16 (240)	24 (360)		1H
4 (60)	-1 (-15)	+4 (+60)	0.2 (3)	16 (240)	24 (360)		1M
10 (150)	-1 (-15)	+10 (+150)	0.5 (7.5)	27 (405)	40 (600)		1P

1) Factory calibration Turn down: Max 20:1, higher on request.

2) The vacuum resistance applies to the measuring cell at reference conditions.

3) Product Configurator, "Sensor range" ordering feature

4) By default, the device is set to a lower range limit of 0 bar. Please specify in the order if the lower range limit is to be set to a different default value.

## Output

### Output signal

- 4 to 20 mA with superimposed digital communication protocol HART 6.0, 2-wire
- Digital communication signal PROFIBUS PA (Profile 3.02)
- Digital communication signal FOUNDATION Fieldbus

Output	Option <sup>1)</sup>
4 to 20mA HART	2
PROFIBUS PA	3
FOUNDATION Fieldbus	4

1) Product Configurator, "Output" ordering feature

### Signal range – 4 to 20 mA HART

3.8 to 20.5 mA

### Signal on alarm

As per NAMUR NE 43

- 4 to 20 mA HART  
Options:
  - Max. alarm: can be set from 21 to 23 mA (Factory setting: 22 mA)
  - Hold measured value: last measured value is held
  - Min. alarm: 3.6 mA
- PROFIBUS PA: can be set in the Analog Input block,  
Options: Last Valid Out Value (factory setting), Fail-safe Value, Status Bad
- FOUNDATION Fieldbus: can be set in the Analog Input block,  
Options: Last Good Value, Fail-safe Value (factory setting), Wrong Value

### Load - 4 to 20 mA HART

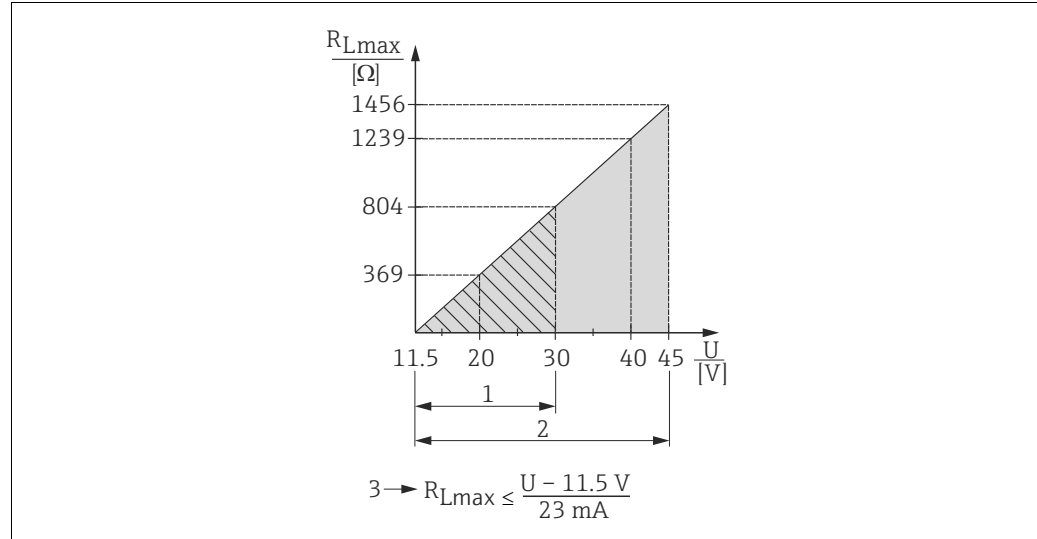

Load diagram

- 1 Power supply 11.5 to 30 V DC for intrinsically safe device versions  
 2 Power supply 11.5 to 45 V DC (versions with plug-in connector 35 V DC) for other types of protection and for uncertified device versions

$R_{Lmax}$  Maximum load resistance  
 $U$  Supply voltage



When operating via a handheld terminal or via a PC with an operating program, a minimum communication resistance of 250 Ω must be taken into account.

**Dead time, time constant**

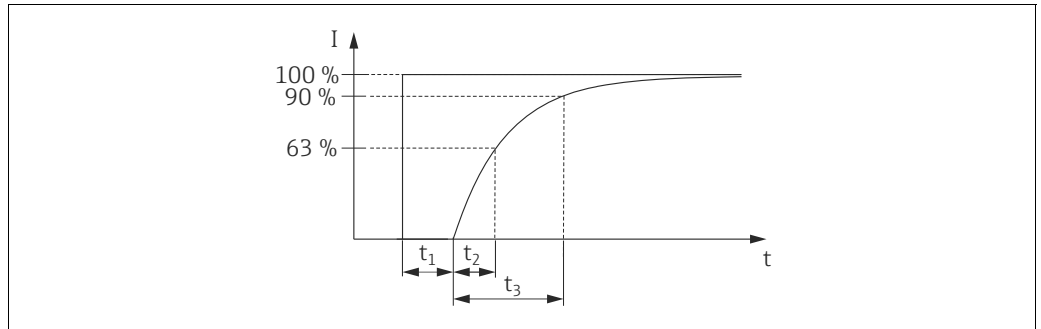

Presentation of the dead time and the time constant

A0019786

**Dynamic behavior:  
current output**

	Type	Dead time ( $t_1$ ) [ms]	Time constant T63 (= $t_2$ ) [ms]	Time constant T90 (= $t_3$ ) [ms]
max.	FMB50	60	90	210
max.	FMB51 FMB52 FMB53	500	250	-

**Dynamic behavior: HART**

	Type	Dead time ( $t_1$ ) [ms]	Dead time ( $t_1$ ) [ms] + Time constant T63 (= $t_2$ ) [ms]	Dead time ( $t_1$ ) [ms] + Time constant T90 (= $t_3$ ) [ms]
min.	FMB50	220	310	370
max.		1020	1110	1170
min.	FMB51	660	910	-
max.	FMB52 FMB53	1460	1710	-

**Reading cycle**

- Acyclic: max. 3/s, typical 1/s (depends on command # and number of preambles)
- Cyclic (Burst): max. 3/s, typical 2/s

The Deltapilot M commands the BURST MODE function for cyclic value transmission via the HART communication protocol.

**Cycle time (update time)**

Cyclic (Burst): min. 300 ms

**Response time**

- Acyclic: min. 330 ms, typical 590 ms (depends on command # and number of preambles)
- Cyclic (Burst): min. 160 ms, typical 350 ms (depends on command # and number of preambles)

**Dynamic behavior:  
PROFIBUS PA**

	Type	Dead time (t <sub>1</sub> ) [ms]	Dead time (t <sub>1</sub> ) [ms] + Time constant T63 (= t <sub>2</sub> ) [ms]	Dead time (t <sub>1</sub> ) [ms] + Time constant T90 (= t <sub>3</sub> ) [ms]
min.	FMB50	95	185	245
max.		1195	1285	1345
min.	FMB51	535	785	-
max.	FMB52 FMB53	1635	1885	-

**Reading cycle**

- Cyclic: max. 30/s (dependent on the number and type of function blocks used in a closed-control loop)
- Acyclic: typical 25/s

**Cycle time (update time)**

min. 100 ms

The cycle time in a bus segment in cyclic data communication depends on the number of devices, on the segment coupler used and on the internal PLC cycle time.

**Response time**

- Cyclic: approx. 8 to 13 ms (depends on Min. Slave Interval)
- Acyclic: approx. 23 to 35 ms (depends on Min. Slave Interval)

**Dynamic behavior:  
FOUNDATION Fieldbus**

	Type	Dead time (t <sub>1</sub> ) [ms]	Dead time (t <sub>1</sub> ) [ms] + Time constant T63 (= t <sub>2</sub> ) [ms]	Dead time (t <sub>1</sub> ) [ms] + Time constant T90 (= t <sub>3</sub> ) [ms]
min.	FMB50	105	195	255
max.		1105	1195	1255
min.	FMB51	545	795	-
max.	FMB52 FMB53	1545	1795	-

**Reading cycle**

- Cyclic: max. 10/s (dependent on the number and type of function blocks used in a closed-control loop)
- Acyclic: typical 5/s

**Cycle time (update time)**

Cyclic: min. 100 ms

**Response time**

- Cyclic: max. 20 ms (for standard bus parameter settings)
- Acyclic: typical 70 ms (for standard bus parameter settings)

**Damping**

A damping affects all outputs (output signal, display).

- Via on-site display, handheld terminal or PC with operating program, continuous from 0...999 s
- Via DIP-switch on the electronic insert, switch position "on" (= set value) and "off" (= damping switched off)
- Factory setting: 2 s

**Firmware version**

Designation	Option <sup>1)</sup>
01.00.zz, FF, DevRev01	76
01.00.zz, PROFIBUS PA, DevRev01	77
01.00.zz, HART, DevRev01	78

1) Product Configurator, "Firmware version" ordering feature



**Galvanic isolation**

The following devices have a galvanic isolation between electronic and probe:

- FMB51, FMB52, FMB53
- FMB50 with separate housing

**Protocol-specific data****HART**

Manufacturer ID	17 (11 hex)
Device Type Code	35 (23 hex)
Device Revision	01 (01 hex) - SW version 01.00.zz
HART specification	6
DD Revision	<ul style="list-style-type: none"> <li>■ 01 (Dutch)</li> <li>■ 02 (Russian)</li> </ul>
Device description files (DTM, DD)	Information and files can be found: <ul style="list-style-type: none"> <li>■ <a href="http://www.endress.com">www.endress.com</a></li> <li>■ <a href="http://www.hartcomm.org">www.hartcomm.org</a></li> </ul>
HART load	Min. 250 $\Omega$
HART device variables	<p>The measured values can be freely assigned to the device variables:</p> <p><b>Measured values for PV (primary variable)</b></p> <ul style="list-style-type: none"> <li>■ Pressure</li> <li>■ Level</li> <li>■ Tank content</li> </ul> <p><b>Measured values for SV, TV (second and third variable)</b></p> <ul style="list-style-type: none"> <li>■ Pressure</li> <li>■ Level</li> </ul> <p><b>Measured values for QV (fourth variable)</b></p> <ul style="list-style-type: none"> <li>■ Temperature</li> </ul>
Supported functions	<ul style="list-style-type: none"> <li>■ Burst mode</li> <li>■ Additional Transmitter Status</li> <li>■ Device Locking</li> <li>■ Alternative operating modes</li> </ul>

**PROFIBUS PA**

Manufacturer ID	17 (11 hex)
Ident number	1554 hex
Profile Version	3.02 <ul style="list-style-type: none"> <li>■ SW Version 01.00.zz</li> </ul>
GSD Revision	5
DD Revision	1
GSD File	Information and files can be found:
DD Files	<ul style="list-style-type: none"> <li>■ <a href="http://www.endress.com">www.endress.com</a></li> <li>■ <a href="http://www.profibus.org">www.profibus.org</a></li> </ul>
Output values	<p><b>Measured values for PV (via Analog Input Function Block)</b></p> <ul style="list-style-type: none"> <li>■ Pressure</li> <li>■ Flow</li> <li>■ Level</li> <li>■ Tank content</li> </ul> <p><b>Measured values for SV</b></p> <ul style="list-style-type: none"> <li>■ Pressure</li> <li>■ Temperature</li> </ul>

Input values	Input value sent from PLC, can be shown on display
Supported functions	<ul style="list-style-type: none"> <li>▪ Identification &amp; Maintenance Simple device identification via control system and nameplate</li> <li>▪ Condensed status<sup>1)</sup></li> <li>▪ Automatic ident number adaptation and switchable to following ident numbers<sup>1)</sup>: <ul style="list-style-type: none"> <li>- 9700: Profile-specific transmitter identification number with the "Classic" or "Condensed" status".</li> <li>- 1503: Compatibility mode for the old Deltapilot M (DB50, DB50L, DB51, DB52, DB53).</li> <li>- 1555: Identification number for the new Deltapilot M (FMB50, FMB51, FMB52, FMB53).</li> </ul> </li> <li>▪ Device locking: The device can be locked by hardware or software.</li> </ul>

1) Only with Profile Version 3.02

### Data of the FOUNDATION Fieldbus interface

#### Basic data

Device Type	0x1023
Device Revision	01 (hex)
DD Revision	0x01021
CFF Revision	0x000102
ITK Version	5.2.0
ITK Certification Driver No.	IT067500
Link-Master (LAS) capable	Yes
Link Master / Basic Device selectable	Yes; Factory setting: Basic Device
Number of VCRs	44
Number of Link Objects in VFD	50
Number of FB-Schedule Objects	40

#### Virtual communication references (VCRs)

Permanent Entries	44
Client VCRs	0
Server VCRs	5
Source VCRs	8
Sink VCRs	0
Subscriber VCRs	12
Publisher VCRs	19

#### Link settings

Slot time	4
Min. inter PDU delay	12
Max. response delay	40

*Transducer Blocks*

Block	Content	Output values
TRD1 Block	Contains all parameters related to the measurement	<ul style="list-style-type: none"> <li>■ Pressure or level (channel 1)</li> <li>■ Process temperature (channel 2)</li> <li>■ Measured pressure value (channel 3)</li> <li>■ Max. pressure (channel 4)</li> <li>■ Level before linearization (channel 5)</li> </ul>
Diagnostic Block	Contains diagnostic information	<ul style="list-style-type: none"> <li>■ Error code via DI channels (channel 10 to 15)</li> </ul>
Display Block	Contains parameters to configure the onsite display	No output values

*Function blocks*

Block	Content	Number of blocks	Execution time	Functionality
Resource Block	The Resource Block contains all the data that uniquely identify the device. It is an electronic version of a nameplate of the device.	1		enhanced
Analog Input Block 1 Analog Input Block 2	The AI Block receives the measuring data from the Sensor Block, (selectable via a channel number) and makes the data available to other function blocks at its output. Enhancement: digital outputs for process alarms, fail safe mode.	2	25 ms	enhanced
Digital Input Block	This block contains the discrete data of the Diagnose Block (selectable via a channel number 10 to 15) and provides them for other blocks at the output.	1	20 ms	Standard
Digital Output Block	This block converts the discrete input and thus initiates an action (selectable via a channel number) in the DP Flow Block or in the TRD1 Block. Channel 20 resets the counter for max. pressure transgressions value and Channel 21 resets the Totalizer.	1	20 ms	Standard
PID Block	The PID Block serves as a proportional-integral-derivative controller and is used almost universally for closed-loop-control in the field including cascade and feedforward. Input IN can be indicated on the display. The selection is performed in the Display Block (DISPLAY_MAIN_LINE_CONTENT).	1	40 ms	Standard
Arithmetic Block	This block is designed to permit simple use of popular measurement math functions. The user does not have to know how to write equations. The math algorithm is selected by name, chosen by the user for the function to be performed.	1	35 ms	Standard
Input Selector Block	The Input Selector Block facilitates the selection of up to four inputs and generates an output based on the configured action. This block normally receives its inputs from AI Blocks. The block performs maximum, minimum, average and 'first good' signal selection. Inputs IN1 to IN4 can be indicated on the display. The selection is performed in the Display Block (DISPLAY_MAIN_LINE_1_CONTENT).	1	30 ms	Standard

Block	Content	Number of blocks	Execution time	Functionality
Signal Characterizer Block	The Signal Characterizer Block has two sections, each with an output that is a non-linear function of the respective input. The non-linear function is generated by a single look-up table with 21 arbitrary x-y pairs.	1	40 ms	Standard
Integrator Block	The Integrator Block integrates a variable as a function of the time or accumulates the counts from a Pulse Input Block. The block may be used as a totalizer that counts up until reset or as a batch totalizer that has a setpoint, where the integrated or accumulated value is compared to pre-trip and trip settings, generating a binary signal when the setpoint is reached.	1	35 ms	Standard

**Additional function block information:**

Instantiate Function Block	YES
Number of instantiate blocks	20

## Power supply

### **▲ WARNING**

#### Incorrect connection can limit electrical safety!

- ▶ When using the measuring device in hazardous areas, installation must comply with the corresponding national standards and regulations and the Safety Instructions or Installation or Control Drawings → 68 ff, "Safety instructions" and "Installation/Control Drawings" ordering features.
- ▶ All explosion protection data are given in separate documentation which is available upon request. The Ex documentation is provided with all Ex-systems as standard → 68 ff, "Safety instructions" and "Installation/Control Drawings" ordering features.
- ▶ According to IEC/EN61010 a suitable disconnector has to be installed for the device
- ▶ HART: Overvoltage protection HAW569-DA2B for the non-hazardous area, ATEX II 2 (1) Ex ia IIC and IEC Ex ia can be ordered as an option (see "Ordering information" ordering feature).
- ▶ Protective circuits against reverse polarity, HF influences and overvoltage peaks are installed.
- ▶ The digital communication signal is transmitted to the bus via a 2-wire connection. The bus also provides the power supply.

### Terminal assignment

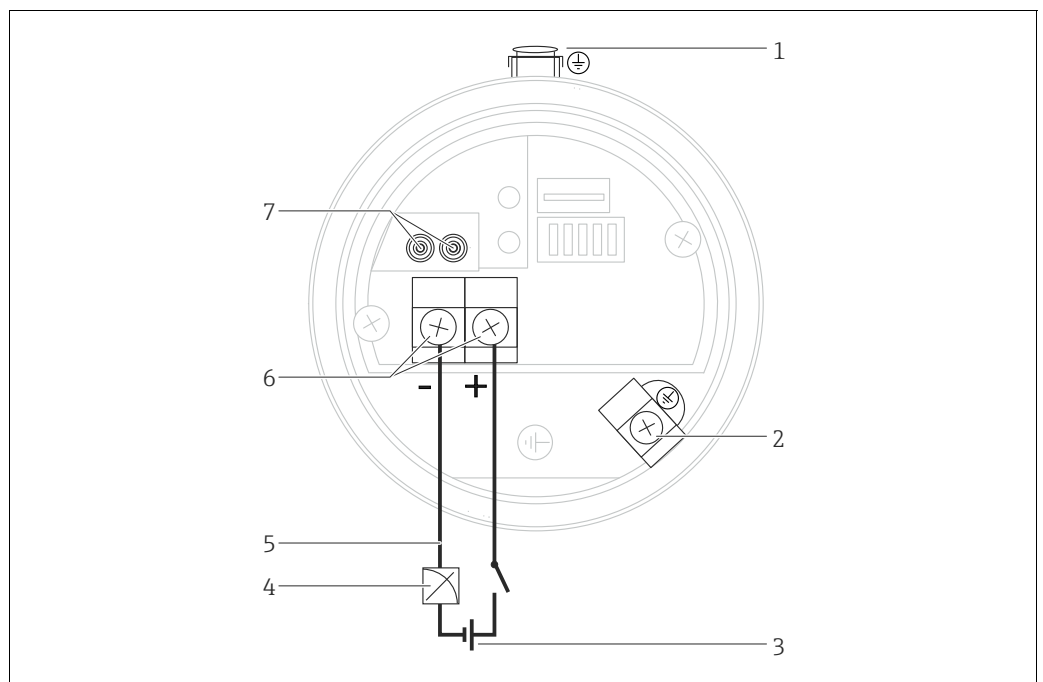

#### Electrical connection

- 1 External grounding terminal
- 2 Internal grounding terminal
- 3 Supply voltage → 21
- 4 4...20 mA for HART devices
- 5 For HART and FOUNDATION Fieldbus devices: With a handheld terminal, all the parameters can be configured anywhere along the bus line via menu operation.
- 6 Terminals
- 7 For HART devices: test terminals, see section "Taking 4 to 20 mA test signal"

### Supply voltage

#### 4 to 20 mA HART

Type of protection	Supply voltage
<ul style="list-style-type: none"> <li>▪ Intrinsically safe</li> </ul>	11.5 ... 30 V DC
<ul style="list-style-type: none"> <li>▪ Other types of protection</li> <li>▪ Devices without certificate</li> </ul>	11.5 to 45 V DC (versions with plug-in connection 35 V DC)

#### Taking 4 to 20 mA test signal

A 4 to 20 mA test signal may be measured via the test terminals without interrupting the measurement.

**PROFIBUS PA**

- Version for non-hazardous areas: 9 to 32 V DC

**FOUNDATION Fieldbus**

- Version for non-hazardous areas: 9 to 32 V DC

**Current consumption**

- PROFIBUS PA: 11 mA ± 1 mA, switch-on current corresponds to IEC 61158-2, Clause 21
- FOUNDATION Fieldbus: 16 mA ± 1 mA, switch-on current corresponds to IEC 61158-2, Clause 21

**Electrical connection**

Cable entry	Degree of protection	Option <sup>1)</sup>
M20 gland	IP66/68 NEMA 4X/6P	A
G ½" thread	IP66/68 NEMA 4X/6P	C
NPT ½" thread	IP66/68 NEMA 4X/6P	D
M12 plug	IP66/67 NEMA 4X/6P	I
7/8" plug	IP66/68 NEMA 4X/6P	M
HAN7D connector, 90 deg	IP65	P
PE cable 5m <sup>2)</sup>	IP66/68 NEMA4X/6P + pressure compensation via cable	S
M16 valve connector	IP64	V

1) Product Configurator, "Electrical connection" ordering feature

2) Only for FMB50

**PROFIBUS PA**

The digital communication signal is transmitted to the bus via a 2-wire connection. The bus also provides the power supply. For further information on the network structure and grounding, and for further bus system components such as bus cables, see the relevant documentation, e.g. Operating Instructions BA00034S "PROFIBUS DP/PA: Guidelines for planning and commissioning" and the PNO Guideline.

**FOUNDATION Fieldbus**

The digital communication signal is transmitted to the bus via a 2-wire connection. The bus also provides the power supply. For further information on the network structure and grounding and for further bus system components such as bus cables, see the relevant documentation, e.g. Operating Instructions BA00013S "FOUNDATION Fieldbus Overview" and the FOUNDATION Fieldbus Guideline.

**Terminals**

For wire cross-sections of 0.5 to 2.5 mm<sup>2</sup> (20 to 14 AWG)

**Cable entry**

Approval	Type	Clamping area
Standard, CSA GP ATEX II1/2G or II2G Ex ia, IEC Ex ia Ga/Gb or Ex ia Gb, FM/ CSA IS	Plastic M20x1.5	5 to 10 mm (0.2 to 0.39 in)
ATEX II1/2D Ex t, II1/2GD Ex ia, II3G Ex nA, IEC Ex t Da/Db	Metal M20x1.5 (Ex e)	7 to 10.5 mm (0.28 to 0.41 in)

For other technical data, see the housing section →  34 ff.

Connector

Devices with valve connector

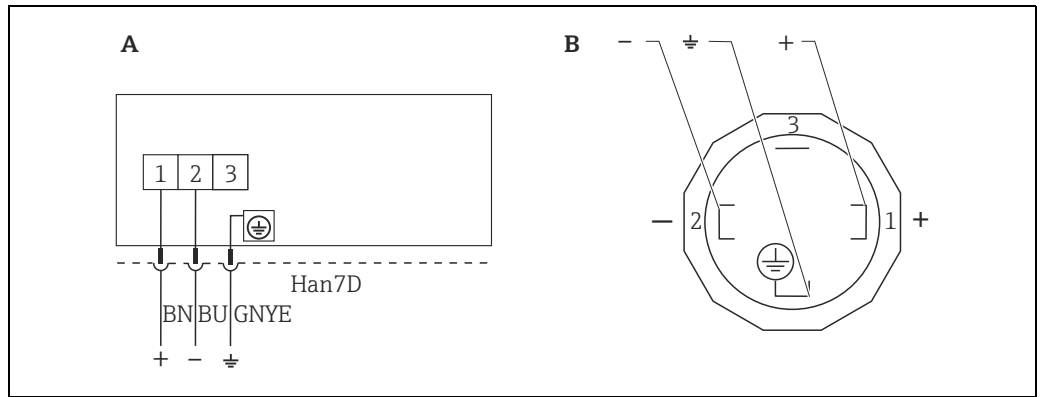

BN = brown, BU = blue, GNYE = green/yellow

A Electrical connection for devices with valve connector  
 B View of the connection on the device

Material: PA 6.6

Devices with Harting plug Han7D

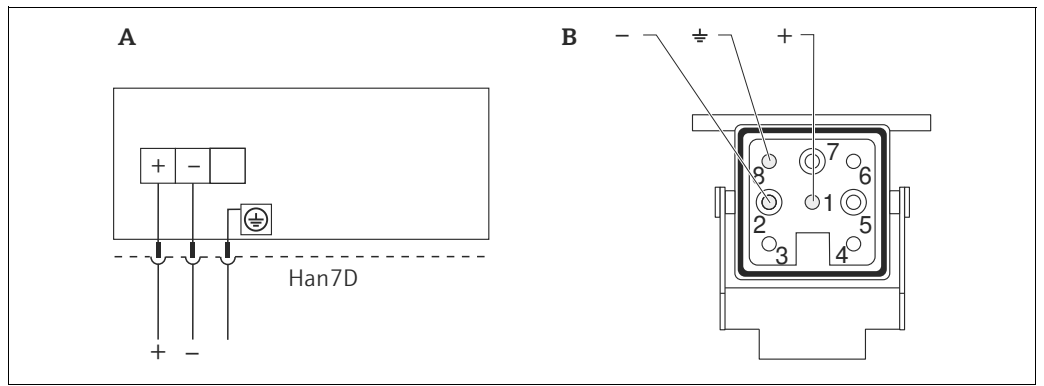

A Electrical connection for devices with Harting plug Han7D  
 B View of the connection on the device

Material: CuZn, gold-plated contacts of plug-in jack and connector

Devices with M12 plug

PIN assignment for M12 connector

PIN assignment for M12 connector	PIN	Meaning
	1	Signal +
	2	Not assigned
	3	Signal -
	4	Earth

Endress+Hauser offers the following accessories for devices with an M12 plug:

Plug-in jack M 12x1, straight

- Material: body PA; coupling nut CuZn, nickel-plated

- Degree of protection (fully locked): IP66/67
- Order number: 52006263

Plug-in jack M 12x1, elbowed

- Material: body PBT/PA; coupling nut GD-Zn, nickel-plated
- Degree of protection (fully locked): IP66/67
- Order number: 71114212

Cable 4x0.34 mm<sup>2</sup> (20 AWG) with M12 socket, elbowed, screw plug, length 5 m (16 ft)

- Material: body PUR; coupling nut CuSn/Ni; cable PVC
- Degree of protection (fully locked): IP66/67
- Order number: 52010285

#### Devices with 7/8" plug

*PIN assignment for 7/8" connector*

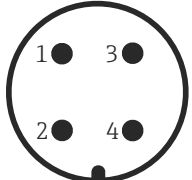
PIN assignment for 7/8" connector	PIN	Meaning
	1	Signal -
	2	Signal +
	3	Not assigned
	4	Shield

External thread: 7/8 - 16 UNC

- Material: 316L (1.4401)
- Protection: IP66/68

#### Cable specification

##### HART

- Endress+Hauser recommends using twisted, shielded two-wire cables.
- The cable outer diameter depends on the cable entry used.

##### PROFIBUS PA

Use a twisted, shielded two-wire cable, preferably cable type A



For further information on the cable specifications, see Operating Instructions BA00034S "PROFIBUS DP/PA: Guidelines for planning and commissioning", the PNO Guideline 2.092 "PROFIBUS PA User and Installation Guideline" and IEC 61158-2 (MBP).

##### FOUNDATION Fieldbus

Use a twisted, shielded two-wire cable, preferably cable type A



For further information on the cable specifications, see Operating Instructions BA00013S "FOUNDATION Fieldbus Overview", FOUNDATION Fieldbus Guideline and IEC 61158-2 (MBP).

#### Start-up current HART

12 mA or 22 mA (selectable)

#### Residual ripple

No influence on 4 to 20 mA signal up to  $\pm 5$  % residual ripple within the permitted voltage range [according to HART hardware specification HCF\_SPEC-54 (DIN IEC 60381-1)]

#### Influence of power supply

$\leq 0.001$  % of URL/V



**Overvoltage protection  
(optional)**

The device can be fitted with overvoltage protection. The overvoltage protection is mounted at the factory on the housing thread (M20x1.5) for the cable gland and is approx. 70 mm (2.76 in) in length (take additional length into account when installing). The device is connected as illustrated in the following graphic.

For details refer to TI001013KEN, XA01003KA3 and BA00304KA2.

Ordering information:

Product Configurator, "Mounted accessories" ordering feature, option NA

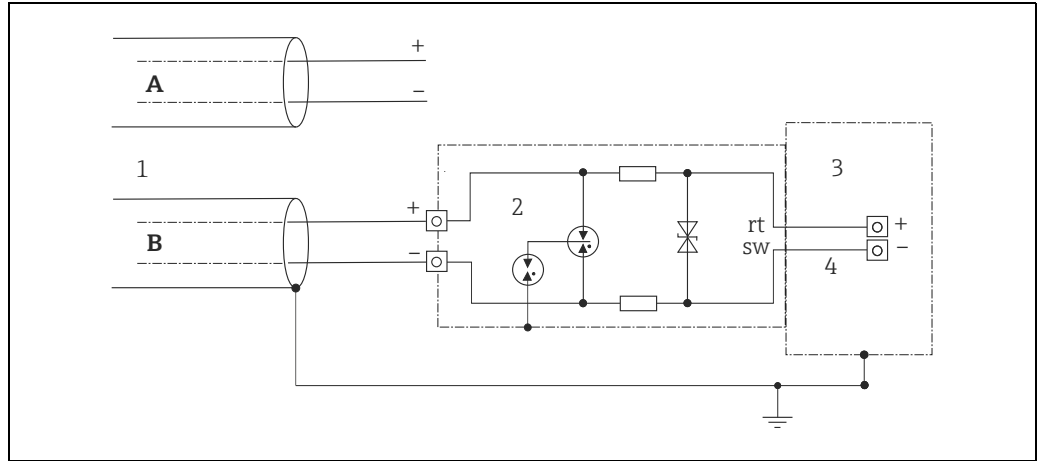

A0023111

- A Without direct shield grounding
- B With direct shield grounding
- 1 Incoming connection cable
- 2 HAW569-DA2B
- 3 Unit to be protected
- 4 Connection cable

## Performance characteristics

### Reference operating conditions

- As per IEC 60770
- Ambient temperature  $T_A$  = constant, in the range of: +21 to +33 °C (+70 to 91°F)
- Humidity  $\phi$  = constant, in the range of: 5 to 80 % RH
- Ambient pressure  $p_A$  = constant, in the range of: 860 to 1060 mbar (12.47 to 15.37 psi)
- Position of the measuring cell: constant, in range: FMB50: horizontally  $\pm 1^\circ$   
FMB51/FMB52/FMB53: vertically  $\pm 1^\circ$
- Input of LOW SENSOR TRIM and HIGH SENSOR TRIM for lower range value and upper range value
- Span based on zero point
- Material of the process isolating diaphragm: Alloy C276 (2.4819) and Alloy C276 (2.4819) with coating (AuRh or AuPt)
- Measuring cell material (meter body): Alloy C276 (2.4819), 316L (1.4435)
- Filling oil: synthetic oil (FDA)/inert oil
- Supply voltage: 24 V DC  $\pm$  3 V DC
- Load with HART: 250  $\Omega$

### Influence of orientation

- < 2.3 mbar (0.0345 psi) when using synthetic oil (FDA)
- < 5 mbar (0.075 psi) when using inert oil



Position-dependent zero point shift can be corrected → 28, "General installation instructions" ordering feature.

### Calibration position

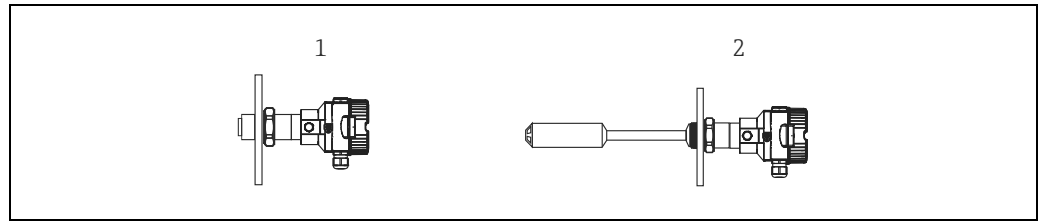

- 1 FMB50  
2 FMB51, FMB52, FMB53

To minimize the effect of the orientation (e.g. in the case of vertical device installation), position offset is preset at the factory.

### Resolution

- Current output: 1  $\mu$ A
- Display: can be set (factory setting: presentation of the maximum accuracy of the transmitter)

### Reference accuracy

The reference accuracy comprises the non-linearity according to limit point setting, hysteresis and non-reproducibility as per IEC 60770. The data refer to the calibrated span.

Reference accuracy in % of the calibrated span			
Measuring cell	TD	"Standard" option <sup>1)</sup>	"Platinum" option <sup>1)</sup>
0.1 bar (1.5 psi)	<ul style="list-style-type: none"> <li>■ TD 1:1 to TD 2:1</li> <li>■ TD &gt; 2:1 to TD 4:1</li> </ul>	<ul style="list-style-type: none"> <li>■ &lt; 0.2</li> <li>■ &lt; 0.1 x TD</li> </ul>	<ul style="list-style-type: none"> <li>■ &lt; 0.15</li> <li>■ &lt; 0.075 x TD</li> </ul>
0.4 bar (6 psi)	<ul style="list-style-type: none"> <li>■ TD 1:1 to TD 4:1</li> <li>■ TD &gt; 4:1 to TD 10:1</li> </ul>	<ul style="list-style-type: none"> <li>■ &lt; 0.2</li> <li>■ &lt; 0.05 x TD</li> </ul>	<ul style="list-style-type: none"> <li>■ &lt; 0.15</li> <li>■ &lt; 0.0375 x TD</li> </ul>
1.2 bar (18 psi)	<ul style="list-style-type: none"> <li>■ TD 1:1 to TD 2:1</li> <li>■ TD &gt; 2:1 to TD 12:1</li> </ul>	<ul style="list-style-type: none"> <li>■ &lt; 0.2</li> <li>■ &lt; 0.1 x TD</li> </ul>	<ul style="list-style-type: none"> <li>■ &lt; 0.1</li> <li>■ &lt; 0.05 x TD</li> </ul>
4 bar (60 psi)	<ul style="list-style-type: none"> <li>■ TD 1:1 to TD 4:1</li> <li>■ TD &gt; 4:1 to TD 20:1</li> </ul>	<ul style="list-style-type: none"> <li>■ &lt; 0.2</li> <li>■ &lt; 0.05 x TD</li> </ul>	<ul style="list-style-type: none"> <li>■ &lt; 0.1</li> <li>■ &lt; 0.025 x TD</li> </ul>
10 bar (150 psi)	<ul style="list-style-type: none"> <li>■ TD 1:1 to TD 2.5:1</li> <li>■ TD &gt; 2.5:1 to TD 20:1</li> </ul>	<ul style="list-style-type: none"> <li>■ &lt; 0.2</li> <li>■ &lt; 0.08 x TD</li> </ul>	<ul style="list-style-type: none"> <li>■ &lt; 0.1</li> <li>■ &lt; 0.04 x TD</li> </ul>

1) Product Configurator, "Reference accuracy" ordering feature

**Thermal change in the zero output and the output span**

Version	Measuring cell	-10 to +60 °C (+14 to +140°F)	60 to 85 °C (140 to 185°F)	Only FMB50: 85 to 100 °C (185 to 212°F)
		% of the calibrated span		
FMB50 FMB51/52/53 snap-on	0.1 bar (1.5 psi)	< (0.32 + 0.30 x TD)	< (0.34 + 0.40 x TD)	< (0.34 + 0.55 x TD)
FMB51/52/53 welded	0.1 bar (1.5 psi)	< (0.32 + 0.50 x TD)	< (0.34 + 0.60 x TD)	-
FMB50/51/52/53	0.4 bar (6 psi)	< (0.31 + 0.25 x TD)	< (0.32 + 0.30 x TD)	-
	1.2 bar (18 psi), 4 bar (60 psi), 10 bar (150 psi)	< (0.31 + 0.10 x TD)	< (0.32 + 0.15 x TD)	< (0.33 + 0.20 x TD)

**Total performance**

The "Total performance" specification comprises the non-linearity including hysteresis, non-reproducibility as well as the thermal change in the zero point.

Total performance in % of the URL				
Version	Measuring cell	-10 to +60 °C (+14 to +140°F)	60 to 85 °C (140 to 185°F)	85 to 100 °C (185 to 212°F)
FMB50 FMB51/52/53 snap-on	0.1 bar (1.5 psi)	< 0.35	< 0.45	< 0.6
FMB51/52/53 welded	0.1 bar (1.5 psi)	< 0.8	< 1	< 1.4
FMB50/51/52/53	0.4 bar (6 psi)	< 0.35	< 0.45	< 0.6
	1.2 bar (18 psi), 4 bar (60 psi), 10 bar (150 psi)	< 0.15	< 0.2	< 0.25

**Long-term stability**

Measuring cell	Long-term stability [%]
0.1 bar (1.4 psi)	<ul style="list-style-type: none"> <li>■ &lt; 0.18 of the upper range limit (URL) / year</li> <li>■ &lt; 0.45 of the upper range limit (URL) / 5 years</li> </ul>
0.4 bar (6 psi) 1.2 bar (18 psi)	<ul style="list-style-type: none"> <li>■ &lt; 0.1 of the upper range limit (URL) / year</li> <li>■ &lt; 0.25 of the upper range limit (URL) / 5 years</li> </ul>
4 bar (60 psi) 10 bar (150 psi)	<ul style="list-style-type: none"> <li>■ &lt; 0.05 of the upper range limit (URL) / year</li> <li>■ &lt; 0.125 of the upper range limit (URL) / 5 years</li> </ul>

**Total error**

The total error comprises the long-term stability and the total performance:

Measuring cell	% of the URL/year (in the permitted temperature range)
0.1 bar (1.5 psi)	<ul style="list-style-type: none"> <li>■ Snap-on: ±0.63</li> <li>■ Welded: ±1.0</li> </ul>
0.4 bar (6 psi)	±0.61
1.2 bar (18 psi)	±0.27
4 bar (60 psi), 10 bar (150 psi)	±0.25

**Warm-up period**

- 4 to 20 mA HART:
  - FMB50 = ≤5 s
  - FMB51/FMB52/FMB53 = ≤8 s
- PROFIBUS PA: ≤8 s
- FOUNDATION Fieldbus: ≤20 s (after a TOTAL-reset ≤45 s)

## Installation

### General installation instructions

- The position-dependent zero point shift can be corrected:
  - directly at the device via an operating key
  - directly at the device via operating keys on the display
  - via digital communication if the cover is not open

#### **▲ WARNING**

##### **Risk of explosion!**

In hazardous areas, comply strictly with the safety instructions when the housing cover is closed and open.

- The local display can be rotated in 90° stages.

### FMB50

#### Level measurement

- Always install the device below the lowest measuring point.
- Do not install the device at the following positions:
  - in the filling curtain
  - in the tank outflow
  - or at a point in the tank that can be affected by pressure pulses from the agitator
- The calibration and functional test can be carried out more easily if you mount the device downstream of a shutoff device.
- Deltapilot M must be included in the insulation for media that can harden when cold.

#### Pressure measurement in gases

Mount Deltapilot M with shutoff device above the tapping point so that any condensate can flow into the process.

#### Pressure measurement in steams

- Mount Deltapilot M with siphon above the tapping point.
- Fill the siphon with liquid before commissioning.  
The siphon reduces the temperature to almost the ambient temperature.



#### Pressure measurement in liquids

Mount Deltapilot M with the shutoff device below or at the same level as the tapping point.

### FMB51/FMB52/FMB53

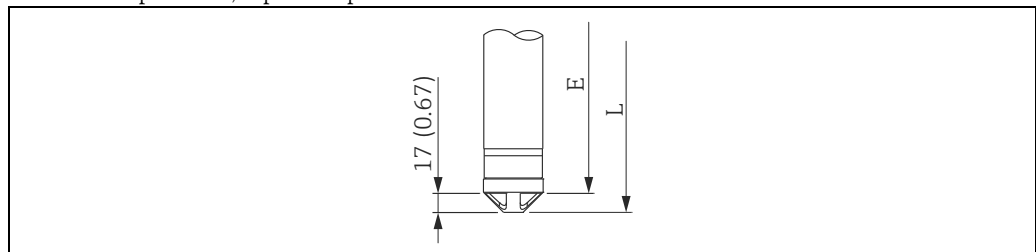
- When mounting rod and cable versions, make sure that the probe head is located at a point as free as possible from flow. To protect the probe from impact resulting from lateral movement, mount the probe in a guide tube (preferably made of plastic) or secure it with a clamping fixture.
- In the case of devices for hazardous areas, comply strictly with the safety instructions when the housing cover is open.
- The length of the extension cable or the probe rod is based on the planned level zero point. The height of the protective cap must be taken into consideration when designing the layout of the measuring point. The level zero point (E) corresponds to the position of the process isolating diaphragm.  
Level zero point = E; top of the probe = L.



- Suspension clamp (required for FMB53)  
Material: →  54 ff  
Ordering information:  
Order number: 52010869 →  64 ff  
Product Configurator, "Accessory enclosed" ordering feature, option "PO".

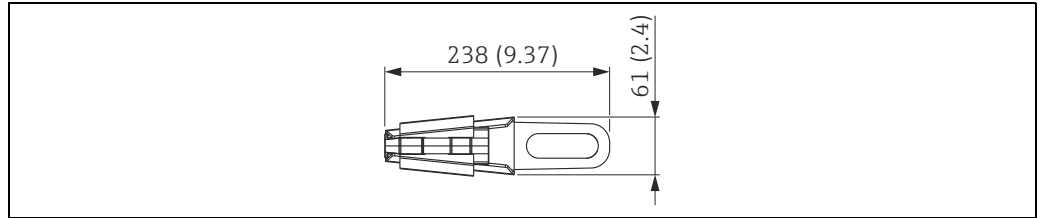

Engineering unit mm (in)

A0023566

## Supplementary installation instructions

### Process isolating diaphragm

- Do not clean or touch process isolating diaphragms with hard or pointed objects.
- The process isolating diaphragm in the rod and cable version is protected against mechanical damage by a plastic cap.

### Seal

- Deltapilot M devices with a G 1 ½ thread:  
When screwing the device into the tank, the flat seal has to be positioned on the sealing surface of the process connection. To avoid additional strain on the process isolating diaphragm, the thread should never be sealed with hemp or similar materials.
- Deltapilot M devices with NPT threads:
  - Wrap Teflon tape around the thread to seal it.
  - Tighten the device at the hexagonal bolt only. Do not turn the device at the housing.
  - Do not overtighten the thread when screwing in the screw. Max. torque: 20 to 30 Nm (14.75 to 22.13 lbf ft)

### Sealing the probe housing

Moisture must not penetrate the housing when mounting the device, establishing the electrical connection and during operation.

- Always firmly tighten the housing cover and the cable entries.
- Lubricant is provided on the O-ring seal in the housing cover and on the thread of the aluminum cover. To ensure that the cover seals tight, any lubricant which has been removed must be replaced. Use silicone grease or graphite paste as the lubricant. Mineral oil-based grease can destroy the O-ring.

### PE cable length > 300 m (984 ft)

- Two suspension clamps must be used for PE cables longer than 300 meters (984 ft).

### Cable length tolerances

- FMB52
  - Cable length < 5 m (16 ft): up to -35 mm (-1.38 in)
  - Cable length 5...10 m (16...33 ft): up to -75 mm (-2.95 in)
  - Cable length 10...100 m (33...328 ft): up to -100 mm (-3.94 in)
- FMB53
  - Cable length < 5 m (16 ft): up to ±17.5 mm (±0.69 in)
  - Cable length 5...10 m (16...33 ft): up to ±37.5 mm (±1.48 in)
  - Cable length 10...100 m (33...328 ft): up to ±50 mm (±1.97 in)

### Rod length tolerances

- FMB51
  - Rod length < 4000 mm (157 in): up to -4 mm (-0.16 in)

## Wall and pipe mounting

Endress+Hauser offers a mounting bracket for installing the device on pipes or walls. The mounting bracket is

- included in the delivery for the FMB50/51/52 with a separate housing (available for order via feature 600) and for the FMB53
- available for order as a separate accessory (Part No.: 71102216).

For the dimensions, see →  48.

**"Separate housing" version**

With the "separate housing" version, you are able to mount the housing with the electronics insert at a distance from the measuring point. This allows for trouble-free measurement:

- Under particularly difficult measuring conditions (at installation locations that are cramped or difficult to access)
- If rapid cleaning of the measuring point is required
- If the measuring point is exposed to vibrations

You can choose between different cable versions:

- PE (2 m (6.6 ft), 5 m (16 ft) and 10 m (33 ft))
- FEP (5 m (16 ft)).

Ordering information:

Product Configurator, "Separate housing" ordering feature

Product Configurator, "Enclosed accessories" ordering feature, option PA

For the dimensions, see → [48](#).

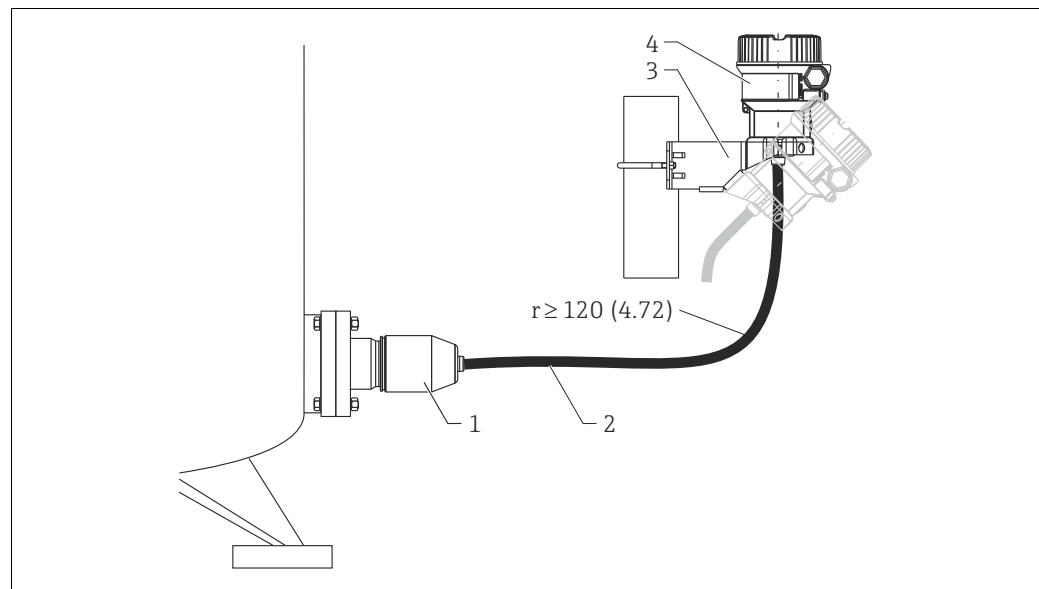

Engineering unit mm (in)

In the case of the "separate housing" version, the sensor is delivered with the process connection and cable ready mounted. The housing and a mounting bracket are enclosed as separate units. The cable is provided with a socket at both ends. These sockets are simply connected to the housing and the sensor.

- 1 Process connection with sensor - see the following section for the degrees of protection
- 2 Cable, both ends are fitted with a socket
- 3 Mounting bracket provided, suitable for pipe and wall mounting (for pipes from 1 1/4" up to 2" diameter)
- 4 Housing with electronic insert - degrees of protection → [32 ff](#)

Degree of protection for the process connection and sensor with the use of

- FEP cable:
  - IP 69K
  - IP 66 NEMA 4/6P
  - IP 68 (1.83 mH<sub>2</sub>O for 24 h) NEMA 4/6P
- PE cable:
  - IP 66 NEMA 4/6P
  - IP 68 (1.83 mH<sub>2</sub>O for 24 h) NEMA 4/6P

Technical data of the PE and FEP cable:

- Minimum bending radius: 120 mm (4.72 in)
- Cable extraction force: max. 450 N (101 lbf)
- Resistance to UV light

Use in hazardous area:

- Intrinsically safe installations (Ex ia/IS)
- FM/CSA IS: for Div.1 installation only



**Oxygen applications**

Oxygen and other gases can react explosively to oils, grease and plastics. As a result, the following are some of the precautions that must be taken:

- All components of the system, such as measuring devices, must be cleaned in accordance with the BAM (DIN 19247) requirements.
- Depending on the materials used, a certain maximum temperature and maximum pressure must not be exceeded for oxygen applications. The maximum temperature  $T_{\max}$  for oxygen applications is 60 °C (140°F).

The devices suitable for gaseous oxygen applications are listed in the following table with the specification  $p_{\max}$ .

Order code for devices <sup>1)</sup> cleaned for oxygen applications	$p_{\max}$ for oxygen applications
FMB50 <sup>2)</sup>	<ul style="list-style-type: none"> <li>▪ Depends on the lowest-rated element, with regard to pressure, of the selected components: over pressure limit (OPL) of the sensor or process connection (1.5 x PN)<sup>3)</sup></li> <li>▪ Depends on filling oil <sup>4)</sup></li> </ul>
FMB51 <sup>2)</sup>	<ul style="list-style-type: none"> <li>▪ Depends on the lowest-rated element, with regard to pressure, of the selected components: over pressure limit (OPL) of the sensor or process connection (1.5 x PN) <sup>3)</sup></li> <li>▪ Depends on filling oil <sup>4)</sup></li> <li>▪ Depends on seal material</li> </ul>

- 1) Only device, not accessory or enclosed accessory
- 2) Product Configurator, "Service" ordering feature, option "HB"
- 3) →  13, "Measuring range" ordering feature and →  34 ff, "Mechanical construction" ordering feature
- 4) Oxygen applications possible with FKM seal and inert oil.

**PWIS cleaning**

Special cleaning of the transmitter to remove paint-wetting substances, for use in paint shops, for instance.

Ordering information:

Product Configurator, "Service" ordering feature, option HC

The stability of the materials used must be checked before using them in the medium.

The protective cap of the process isolating diaphragm must be removed if necessary (FMB51/FMB52/FMB53).

**Applications with hydrogen**

With regard to materials in which hydrogen formation takes place (e.g. digested sludge), hydrogen atoms can diffuse through the metal process isolating diaphragm. This can result in incorrect measurement results.

Endress+Hauser offers process isolating diaphragms with a gold/rhodium coating for such instances.

Ordering information:

Product Configurator, "Process isolating diaphragm material" ordering feature, option L

**NOTICE**

**To reduce the formation of hydrogen, you should not use galvanized assemblies.**

**Special measuring cells for acids, alkalis or sea water (not FMB50)**

For acids, alkalis or sea water, Endress+Hauser offers process isolating diaphragms with a gold/platinum coating.

**NOTICE**

**With temperature exposure (up to 85°C(185°F)) there is an additional zero point deviation of 1.1 mbar (0.0165 psi).**

Ordering information:

Product Configurator, "Process isolating diaphragm material" ordering feature, option N

## Environment

### Ambient temperature limits

Version	FMB50	FMB51	FMB52	FMB53
Without LCD display	-40 °C to +85 °C (-40°F to +185°F)		With PE cable: -40 °C to +70 °C (-40°F to +158°F) With FEP cable: -40 °C to +80 °C (-40°F to +176°F)	
With LCD display <sup>1)</sup>	-20 °C to +70 °C (-4°F to +158°F)			
With M12 plug , elbowed	-25 °C to +85 °C (-13°F to +185°F)		With PE cable: -25 °C to +70 °C (-13°F to +158°F) With FEP cable: -25 °C to +80 °C (-13°F to +176°F)	
With separate housing (PE and FEP cable)	-20 °C to +60 °C (-4°F to +140°F)			

- 1) Extended temperature application range (-40 °C to +85 °C (-40°F to +185°F)) with restrictions in optical properties such as display speed and contrast

### Storage temperature range

Version	FMB50	FMB51	FMB52	FMB53
Without LCD display	-40 °C to +90 °C (-40°F to +194°F)		With PE cable: -40 °C to +70 °C (-40°F to +158°F) With FEP cable: -40 °C to +80 °C (-40°F to +176°F)	
With LCD display	-40 °C to +85 °C (-40°F to +185°F)			
With M12 plug , elbowed	-25 °C to +90 °C (-13°F to +194°F)		With PE cable: -25 °C to +70 °C (-13°F to +158°F) With FEP cable: -25 °C to +80 °C (-13°F to +176°F)	
With separate housing and FEP cable	-20 °C to +60 °C (-4°F to +140°F)			

### Climate class

Class 4K4H (air temperature: -20 to 55 °C (-4 to +131°F), relative humidity: 4 to 100%) satisfied as per DIN EN 60721-3-4 (condensation possible)

### Degree of protection

- F31 housing: IP 68 (1.83 mH<sub>2</sub>O for 24 h)
- Ordering information:  
Product Configurator, "Electrical connection" ordering feature
- Separate housing →  30

### Vibration resistance

Device/accessory	Test standard	Vibration resistance
FMB50, FMB52, FMB53	GL VI-7-2 <ul style="list-style-type: none"> <li>■ Part 7: Guidelines for the Performance of Type Approvals</li> <li>■ Chapter 2: Test Requirements for Electrical / Electronic Equipment and Systems</li> </ul>	Guaranteed for: 5 to 25 Hz: ±1.6 mm (0.06 in); 25 to 100 Hz: 4 g in all 3 planes
FMB50, FMB52, FMB53 with mounting bracket	IEC 61298-3	Guaranteed for: 10 to 60 Hz: ±0.15 mm (0.01 in); 60 to 500 Hz: 2 g in all 3 planes
FMB51	IEC 60068-2-6	Guaranteed for: 10 to 60 Hz: ±0.075 mm (0.003 in) 60 to 150 Hz 1g in all 3 planes

### Electromagnetic compatibility

- Electromagnetic compatibility as per all the relevant requirements of the EN 61326 series and NAMUR Recommendation EMC (NE21). Details can be found in the Declaration of Conformity (in the Download area of "www.de.endress.com", "search area - Approvals and Certificates", "Manufact. Declaration").
- Max. deviation during EMC-tests < 0.5% of the span
- All tests were performed with full measurement range (TD 1:1).



## Process

### Process temperature range

FMB50	FMB51	FMB52	FMB53
-10 °C to +100 °C (+14°F to 212°F) 135 °C (275°F) for 30 min. maximum	-10 °C to +85 °C (+14°F to +185°F)	With PE cable: -10 °C to +70 °C (-14°F to 158°F) With FEP cable: -10 °C to +80 °C (-14°F to 176°F)	
	Min. process temperature when using the KALREZ seal: -3 °C (27°F)		

Lateral load FMB51 (static) ≤30 Nm

### Pressure specifications

#### ▲ WARNING

The maximum pressure for the measuring device depends on the lowest-rated element with regard to pressure → 13 ff. "Measuring range" ordering feature and → 34 ff. "Mechanical construction" ordering feature

- ▶ Only operate the measuring device within the prescribed limits!
- ▶ The MWP (maximum working pressure) is specified on the nameplate. This value refers to a reference temperature of +20 °C (68°F), (100°F (38 °C) for ANSI flanges), and may be applied to the device for an unlimited time. Pay attention to pressure-temperature dependencies.
- ▶ Please refer to the following standards for pressure values permitted at higher temperatures EN 1092-1: 2001 Tab. 18 <sup>1)</sup>  
ASME B 16.5a – 1998 Tab. 2-2.2 F316  
ASME B 16.5a – 1998 Tab. 2.3.8 N10276  
JIS B 2220.
- ▶ The MWP applies for the temperature ranges indicated in the "Ambient temperature limits" (→ 32) and "Process temperature limits" ordering features (see above).
- ▶ The test pressure corresponds to the over pressure limit of the device (OPL = 1.5 x MWP) and may be applied for only a limited time period in order to avoid permanent damage.
- ▶ The Pressure Equipment Directive (EC Directive 97/23/EC) uses the abbreviation "PS". The abbreviation "PS" corresponds to the MWP (maximum working pressure) of the measuring device.
- ▶ In the case of sensor range and process connection combinations where the OPL (over pressure limit) of the process connection is smaller than the nominal value of the sensor, the device is set at the factory, at the very maximum, to the OPL value of the process connection. If you want to use the entire sensor range, select a process connection with a higher OPL value (1.5 x PN; PN = MWP).
- ▶ In oxygen applications, the values for "p<sub>max</sub> and T<sub>max</sub> for oxygen applications" as per → 31, "Oxygen applications" ordering feature may not be exceeded.

1) With regard to their stability-temperature property, the materials 1.4435 and 1.4404 are grouped together under 13EO in EN 1092-1 Tab. 18. The chemical composition of the two materials can be identical.

## Mechanical construction

### Device height

The device height is calculated from

- the height of the housing and
- the height of the individual process connection.

The individual heights of the components are listed in the following sections. To calculate the device height simply add up the individual heights of the components. Where applicable also take into consideration the installation distance (space that is used to install the device).

You can use the following table for this purpose:

Section	Page	Height
Housing height	→ 34 ff	
Process connections	→ 35 ff	
Installation distance		
Device height		

### F31 housing, aluminum

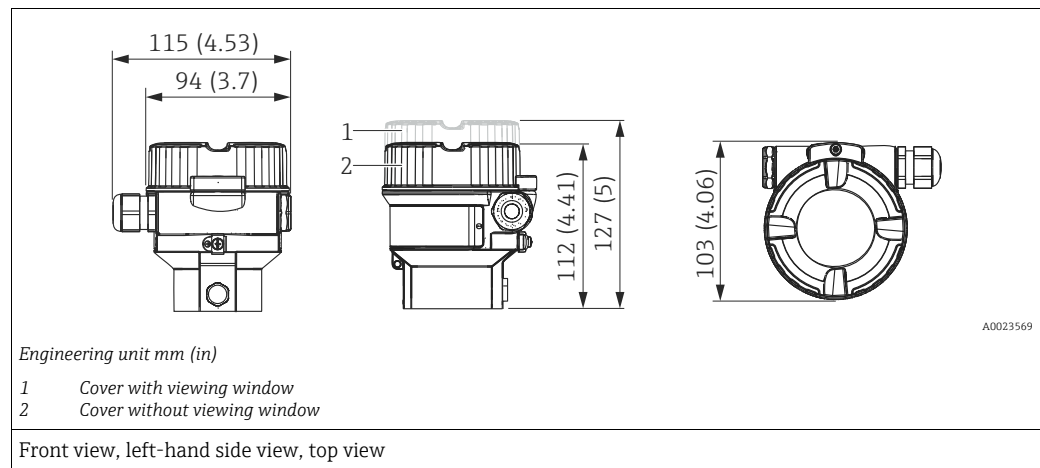

Material	Weight kg (lbs)		Option <sup>1)</sup>
	With display	Without display	
Aluminum	1.1 (2.43)	1.0 (2.21)	I
Aluminum with glass viewing window			J

1) Product Configurator, "Housing" ordering feature

**F15 housing, stainless steel (hygienic)**

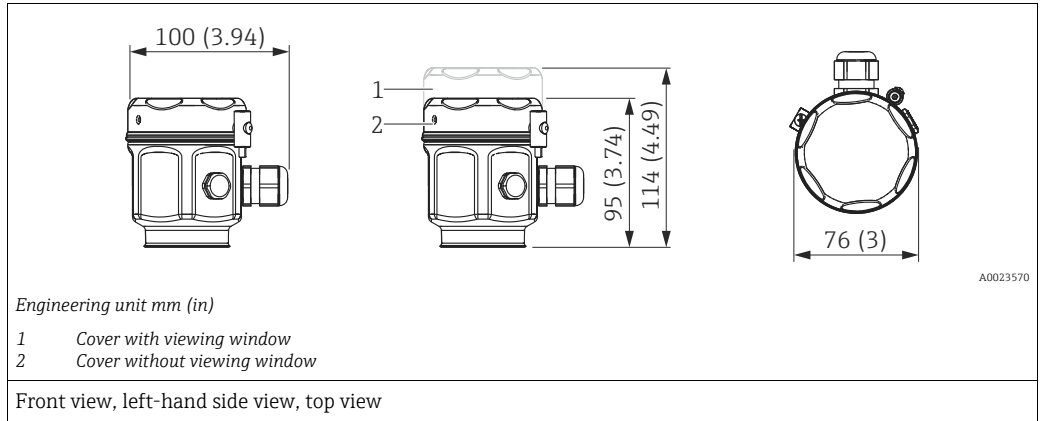

Material	Weight kg (lbs)		Option <sup>1)</sup>
	With display	Without display	
Stainless steel	1.1 (2.43)	1.0 (2.21)	Q
Stainless steel with glass viewing window			R
Stainless steel with plastic viewing window			S

1) Product Configurator, "Housing" ordering feature

**Process connections FMB50, FMB51, FMB52**

**ISO 228 G threaded connection**

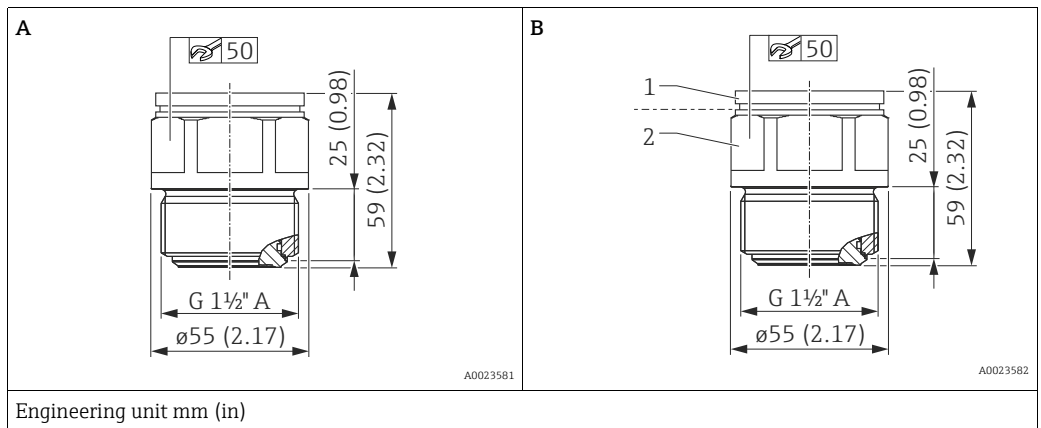

Item	Designation	Material	Weight kg (lbs)	Option <sup>1)</sup>
A	Thread ISO 228 G 1 ½" A	AISI 316L (1.4435)	0.8 (1.76)	GGJ
B	Thread ISO 228 G 1 ½" A	<ul style="list-style-type: none"> <li>▪ 1: top section AISI 316L (1.4435)</li> <li>▪ 2: bottom section Alloy C276 (2.4819)</li> </ul>		GGC

1) Product Configurator, "Process connection" section

**Threaded connection NPT**

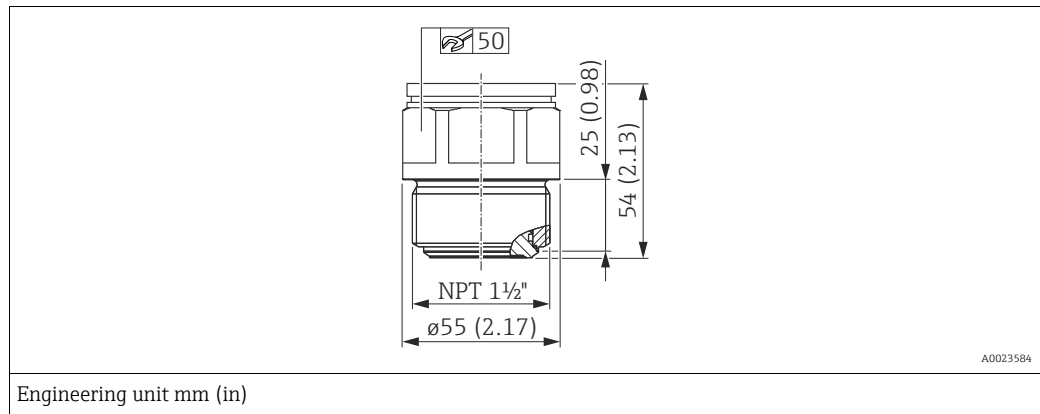

Designation	Material	Weight kg (lbs)	Option <sup>1)</sup>
Thread ANSI 1 1/2" MNPT	AISI 316L (1.4435)	0.8 (1.76)	RGJ

1) Product Configurator, "Process connection" section

**Process connections FMB50, FMB51, FMB52**

**EN/DIN flanges, connection dimensions as per EN 1092-1/DIN 2527**

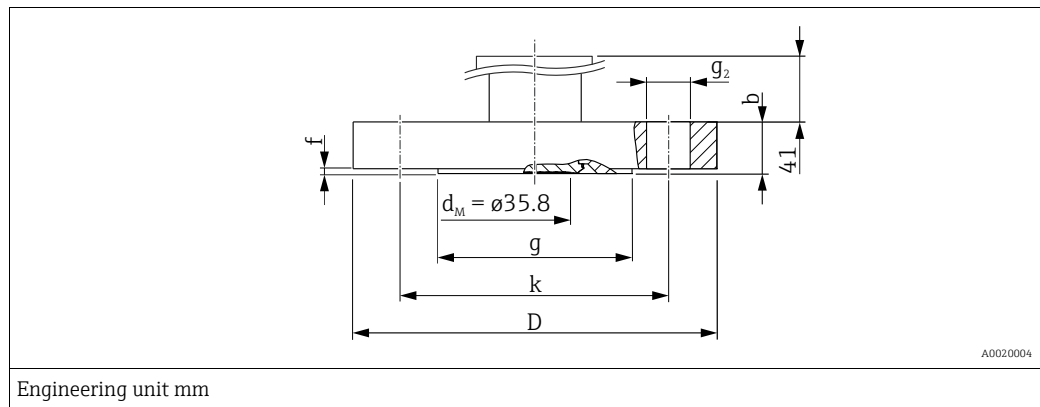

Flange <sup>1)</sup>								Boltholes			Weight	Option <sup>2)</sup>
Material <sup>3)</sup>	Nominal diameter	Nominal pressure	Shape <sup>4)</sup>	Diameter	Thick-ness	Diameter of raised face	Height of raised face	Quant-ity	Diameter	Hole circle		
				D	b	g	f		g <sub>2</sub>	k	[kg (lbs)]	
				[mm]	[mm]	[mm]	[mm]		[mm]	[mm]		
AISI 316L	DN 40	PN 10/16	B1 (C)	150	18	88	2	4	18	110	3.05 (6.72)	CEJ
AISI 316L	DN 50	PN 10/16	B1 (C)	165	18	102	2	4	18	125	3.75 (8.27)	CFJ
AISI 316L	DN 80	PN 10/16	B1 (C)	200	20	138	2	8	18	160	5.55 (12.24)	CGJ
AISI 316L	DN 100	PN 10/16	B1 (C)	220	20	158	2	8	18	180	6.75 (14.88)	CHJ

1) The roughness of the surface in contact with the medium, including the sealing surface of the flanges, is <math>R\_a 0.8 \mu m (31.5 \mu in)</math>. Lower surface roughness available on request.

2) Product Configurator, "Process connection" section

3) Endress+Hauser supplies DIN/EN stainless steel flanges as per AISI 316L (DIN/ EN material number 1.4404 or 14435). With regard to their stability-temperature property, the materials 1.4404 and 1.4435 are grouped together under 13E0 in EN 1092-1: 2001 Tab.18. The chemical composition of the two materials can be identical.

4) Designation as per DIN 2526 in brackets

Process connections FMB50, FMB51, FMB52 - continued ASME flanges, connection dimensions as per ANSI B 16.5, raised face RF

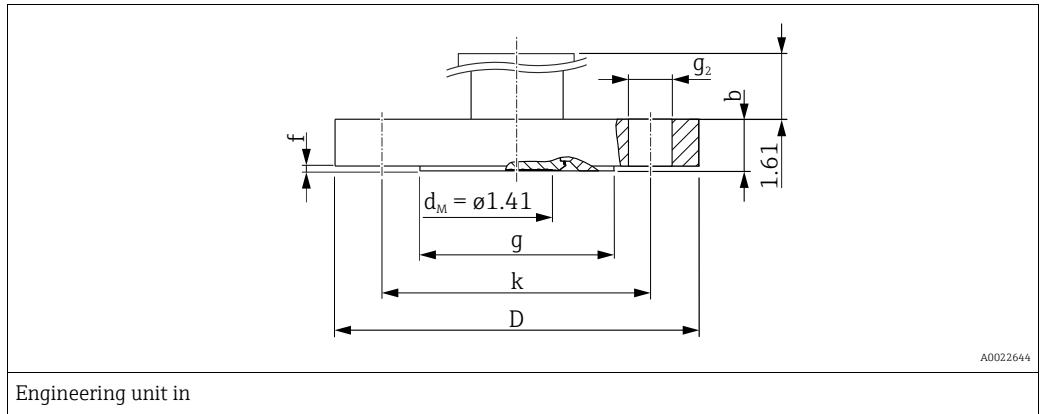

Flange <sup>1)</sup>							Boltholes			Weight	Option <sup>2)</sup>
Material <sup>3)</sup>	Nominal diameter	Class	Diameter	Thick-ness	Diameter of raised face	Height of raised face	Quantity	Diameter	Hole circle		
	[in]	[lb./sq in]	D	b	g	f		g <sub>2</sub>	k	[kg (lbs)]	
AISI 316/316L	1 ½	150	5	0.69	2.88	0.06	4	0.62	3.88	2.55 (5.62)	AEJ (not FMB51/52)
AISI 316/316L	2	150	6	0.75	3.62	0.06	4	0.75	4.75	3.45 (7.61)	AFJ
AISI 316/316L	3	150	7.5	0.94	5	0.06	4	0.75	6	6.15 (13.56)	AGJ
AISI 316/316L	4	150	9	0.94	6.19	0.06	8	0.75	7.5	8.25 (18.19)	AHJ

- 1) The roughness of the surface in contact with the medium, including the sealing surface of the flanges, is <math>R\_a 0.8 \mu m (31.5 \mu in)</math>. Lower surface roughness available on request.
- 2) Product Configurator, "Process connection" section
- 3) Combination of AISI 316 for required pressure resistance and AISI 316L for required chemical resistance (dual rated)

Process connections FMB50,  
FMB51, FMB52 - continued

JIS flanges, connection dimensions as per JIS B 2220 BL, raised face RF

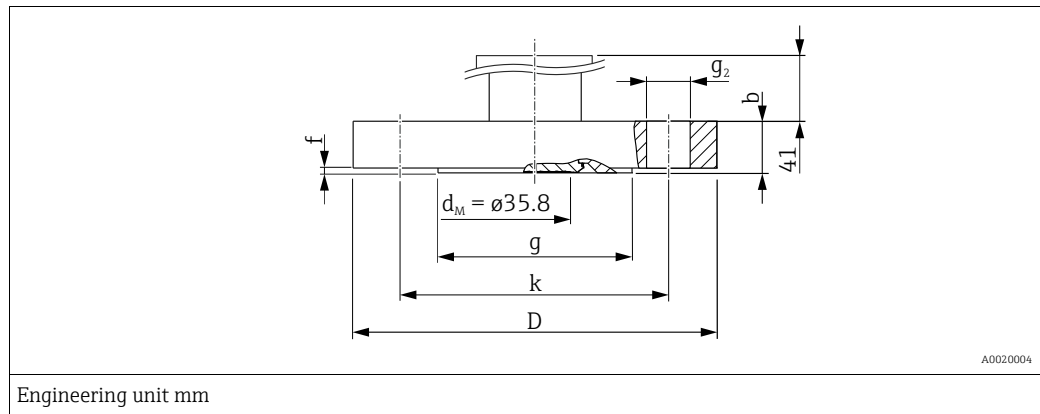

Flange <sup>1)</sup>							Boltholes			Weight	Option <sup>2)</sup>
Material	Nominal diameter	Nominal pressure	Diameter D	Thick- ness b	Diameter of raised face g	Height of raised face f	Quantity	Diameter g <sub>2</sub>	Hole circle k		
			[mm]	[mm]	[mm]	[mm]		[mm]	[mm]	[kg (lbs)]	
AISI 316L (1.4435)	40 A	10 K	140	16	81	2	4	19	105	2.55 (5.62)	KEJ
	50 A	10 K	155	16	96	2	4	19	120	2.95 (6.50)	KFJ
	80 A	10 K	185	18	126	2	8	19	150	4.25 (9.37)	KGJ
	100 A	10 K	210	18	151	2	8	19	175	5.35 (11.79)	KHJ

1) The roughness of the surface in contact with the medium, including the sealing surface of the flanges (all standards), is <math>R\_a 0.8 \mu\text{m}</math> (31.5  $\mu\text{in}</math>). Lower surface roughness available on request.$

2) Product Configurator, "Process connection" section

**Process connections FMB50 - Universal adapter**  
continued

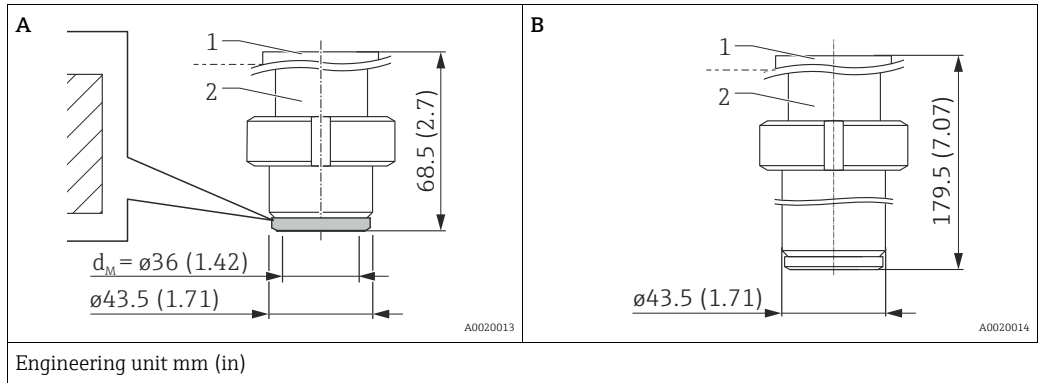

Item <sup>1)</sup>	Designation	Material	Approval	Weight kg (lbs)	Option <sup>2)</sup>
A	Universal process adapter incl. silicone molded seal (spare part no.: 52023572) FDA 21CFR177.2600/USP Class VI-70C	<ul style="list-style-type: none"> <li>1: top section AISI 316L (1.4404)</li> <li>2: bottom section AISI 316L (1.4435)</li> </ul>	EHEDG, 3A	0.8 (1.76)	UPJ <sup>3)</sup>
	Universal process adapter incl. EPDM molded seal (order no.: 71100719) EPDM-70, FDA, USP Class VI; (5 pieces)				UNJ <sup>3)</sup>
B	Universal process adapter, 6 inch extension incl. silicone molded seal (spare part no.: 52023572) FDA 21CFR177.2600/USP Class VI-70C		EHEDG, 3A	1.7 (3.75)	UQJ <sup>3)</sup>
	Universal process adapter, 6 inch extension incl. EPDM molded seal (order no.: 71100719) EPDM-70, FDA, USP Class VI; (5 pieces)				UOJ <sup>3)</sup>

- 1) Surface roughness of the surfaces in contact with the medium  $R_a \leq 0.76 \mu\text{m}$  (30  $\mu\text{in}$ ) as standard. Surface roughness  $R_a < 0.38 \mu\text{m}$  electropolished (wetted) Ordering information: Product Configurator, "Service" ordering feature, option "HK".
- 2) Product Configurator, "Process connection" section
- 3) Endress+Hauser supplies these slotted nuts in stainless steel AISI 304 (1.4301) or in AISI 304L (1.4307).

**Anderson process adapter**

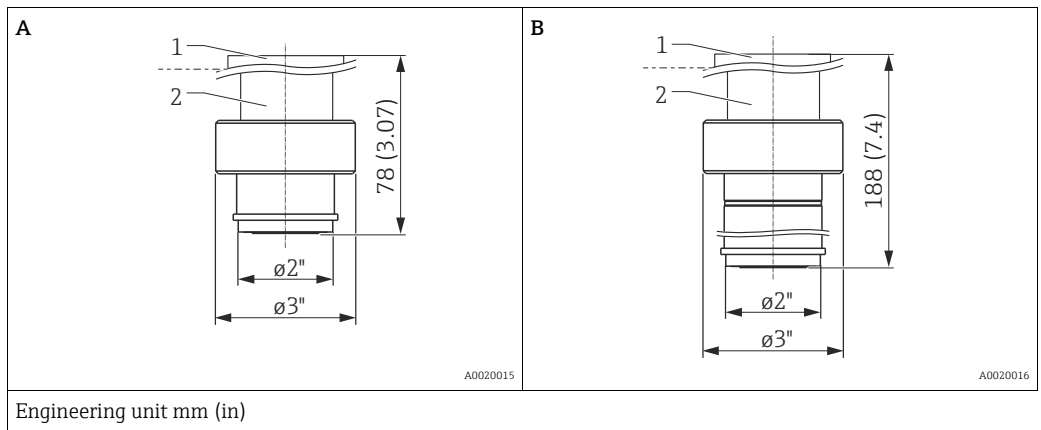

Item <sup>1)</sup>	Designation	Material	Approval	Weight kg (lbs)	Option <sup>2)</sup>
A	Short Anderson process adapter, 2-3/16", 316L, incl. silicone molded seal FDA 21CFR177.2600	<ul style="list-style-type: none"> <li>1: top section AISI 316L (1.4404)</li> <li>2: bottom section AISI 316L (1.4435)</li> </ul>	3A	1.5 (3.31)	USJ
B	Long Anderson process adapter, 6-1/2", 316L, incl. silicone molded seal FDA 21CFR177.2600		<ul style="list-style-type: none"> <li>Slotted nut AISI 316L (1.4404)</li> </ul>	3A	2.9 (6.39)

- 1) Surface roughness of the surfaces in contact with the medium  $R_a \leq 0.76 \mu\text{m}$  (30  $\mu\text{in}$ ) as standard. Lower surface roughness available on request.
- 2) Product Configurator, "Process connection" section

Process connections FMB50 - Hygienic connections  
continued

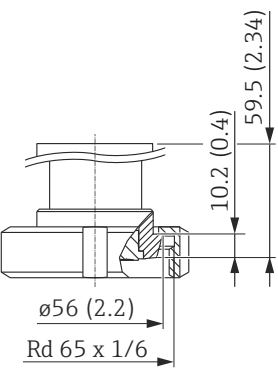
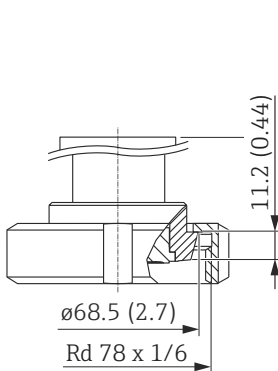
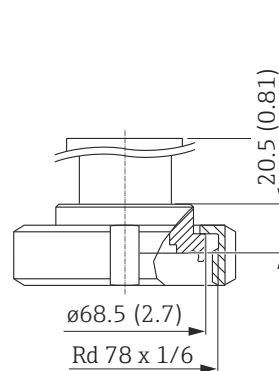
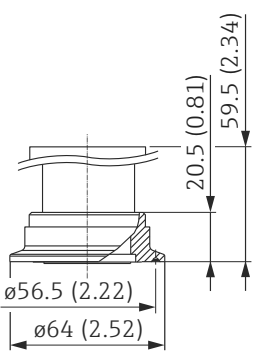
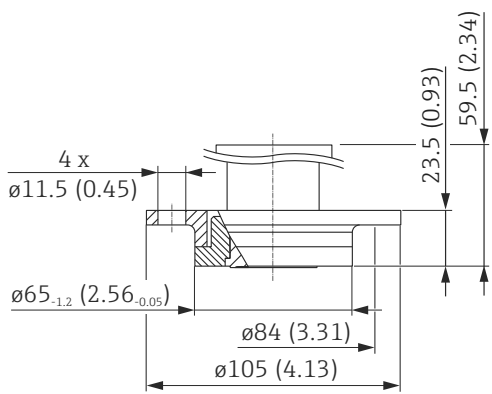
<p><b>A</b></p>  <p>10.2 (0.4) 59.5 (2.34) ø56 (2.2) Rd 65 x 1/6</p> <p>A0020005</p>	<p><b>B</b></p>  <p>11.2 (0.44) 59.5 (2.34) ø68.5 (2.7) Rd 78 x 1/6</p> <p>A0020006</p>	<p><b>C</b></p>  <p>20.5 (0.81) 59.5 (2.34) ø68.5 (2.7) Rd 78 x 1/6</p> <p>A0020007</p>
<p><b>D</b></p>  <p>20.5 (0.81) 59.5 (2.34) ø56.5 (2.22) ø64 (2.52)</p> <p>A0020008</p>	<p><b>E</b></p>  <p>4 x ø11.5 (0.45) 23.5 (0.93) 59.5 (2.34) ø65<sub>-1.2</sub> (2.56<sub>-0.05</sub>) ø84 (3.31) ø105 (4.13)</p> <p>A0020009</p>	
<p>Engineering unit mm (in)</p>		

Item <sup>1)</sup>	Designation	Material	Approval	Weight kg (lbs)	Option <sup>2)</sup>
A	DIN 11851 DN 40 PN 25	AISI 316L (1.4435)	EHEDG, 3A	0.7 (1.54)	MZJ <sup>3)</sup>
B	DIN 11851 DN 50 PN 25		EHEDG, 3A	0.9 (1.98)	MRJ <sup>3)</sup>
C	DIN11864-1 A DN50 PN16 pipe DIN11866-A, slotted nut, 316L		EHEDG, 3A	1 (2.21)	NDJ <sup>3)</sup>
D	Tri-Clamp ISO 2852 DN 40 – DN 51 (2"), DIN 32676 DN 50		EHEDG, 3A	0.7 (1.54)	TDJ <sup>3)</sup>
E	DRD DN 50 (65 mm) PN 25, slotted nut AISI 304 (1.4301)		-	1.1 (1.98)	TIJ

1) Surface roughness of the surfaces in contact with the medium  $R_a \leq 0.76 \mu\text{m}$  (30  $\mu\text{in}$ ) as standard. Lower surface roughness available on request.

2) Product Configurator, "Process connection" section

3) Endress+Hauser supplies these slotted nuts in stainless steel AISI 304 (DIN/EN material number 1.4301) or in AISI 304L (DIN/EN material number 1.4307).



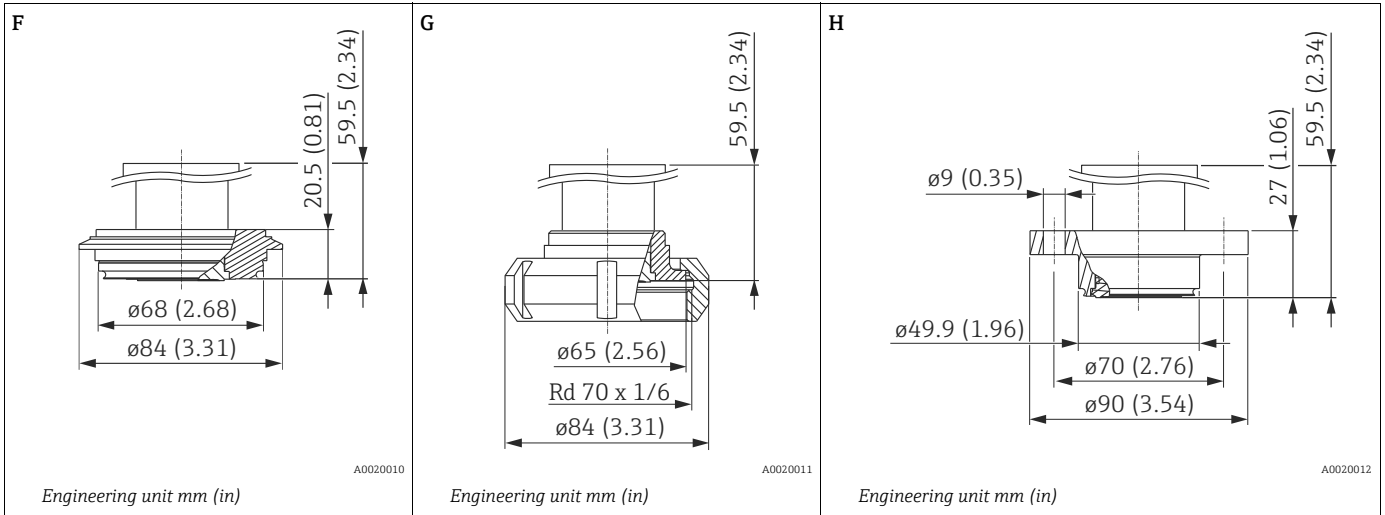

Item <sup>1)</sup>	Designation	Material	Approval	Weight kg (lbs)	Option <sup>2)</sup>
F	Varivent Type N for pipes 40 – 162, PN 40	AISI 316L (1.4435)	EHEDG, 3A	1 (2.21)	TRJ
G	SMS 2", PN 25		EHEDG	0.7 (1.54)	TXJ <sup>3)</sup>
H	NEUMO, D50, PN 16, 316L		3A	0.8 (1.76)	S4J

- 1) Surface roughness of the surfaces in contact with the medium  $R_a \leq 0.76 \mu\text{m}$  (30  $\mu\text{in}$ ) as standard. Lower surface roughness available on request.
- 2) Product Configurator, "Process connection" section
- 3) Endress+Hauser supplies these slotted nuts in stainless steel AISI 304 (DIN/EN material number 1.4301) or in AISI 304L (DIN/EN material number 1.4307).

Process connections FMB51  
(rod version)

Threaded connection ISO 228 and NPT

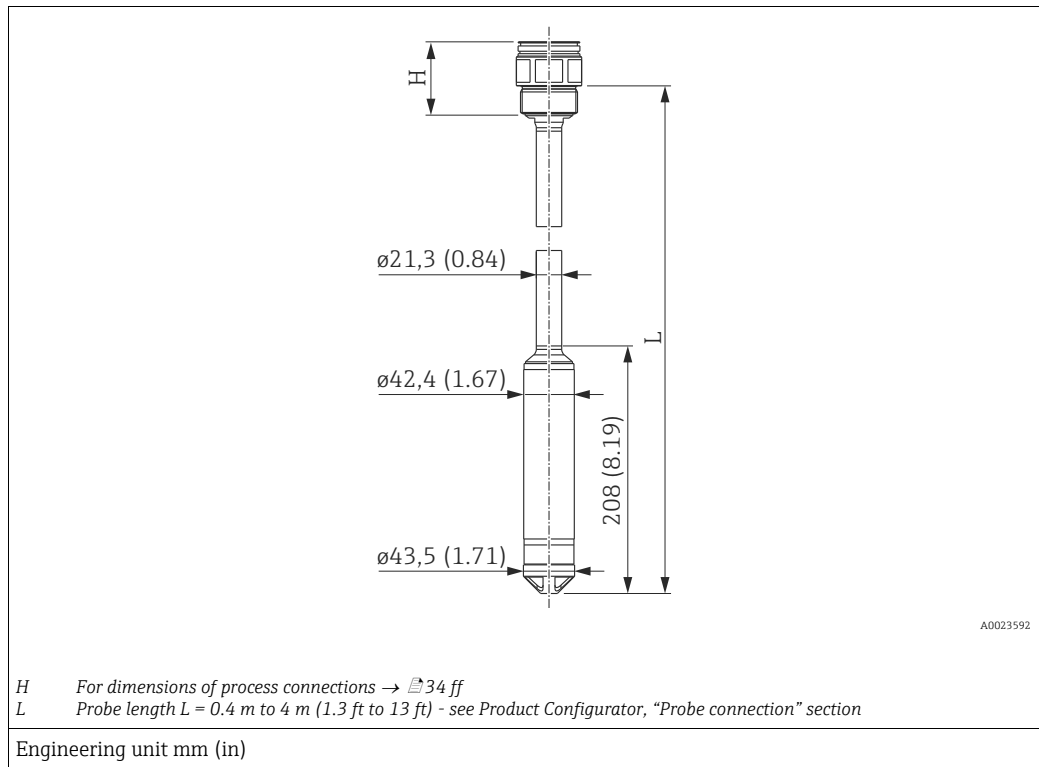

Process connection incl. sensor	Weight
Housing weight	→ 34 ff
Process connection weight	→ 35 ff
Pipe incl. cable	0.77 kg/m (1.70 lbs/3.3 ft)
Threaded connection incl. measuring cell tube and sensor	1.65 kg (3.64 lbs)
Flange connection incl. measuring cell tube and sensor, without a flange	-
Total weight of device	

EN/DIN, ANSI and JIS flanges

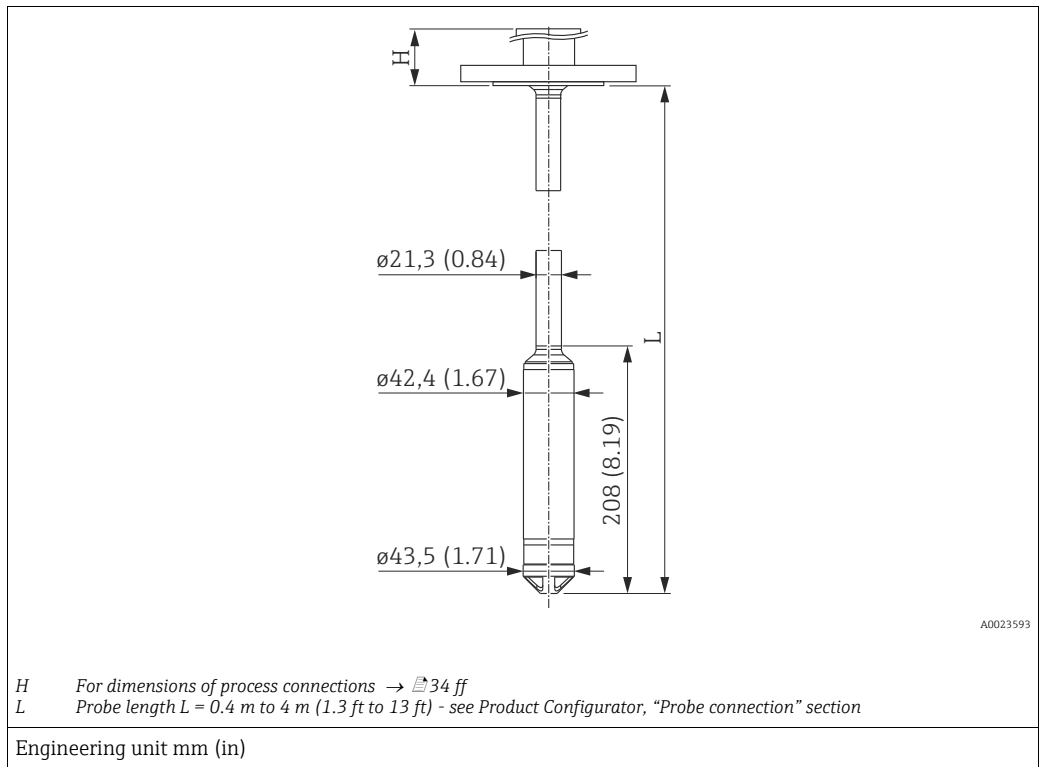

Process connection incl. sensor	Weight
Housing weight	→ 34 ff
Process connection weight	→ 35 ff
Pipe incl. cable	0.77 kg/m (1.70 lbs/3.3 ft)
Threaded connection incl. measuring cell tube and sensor	-
Flange connection incl. measuring cell tube and sensor, without a flange	1.3 kg (2.87 lbs)
Total weight of device	

Process connections FMB52  
(cable version)

Threaded connection ISO 228 and NPT

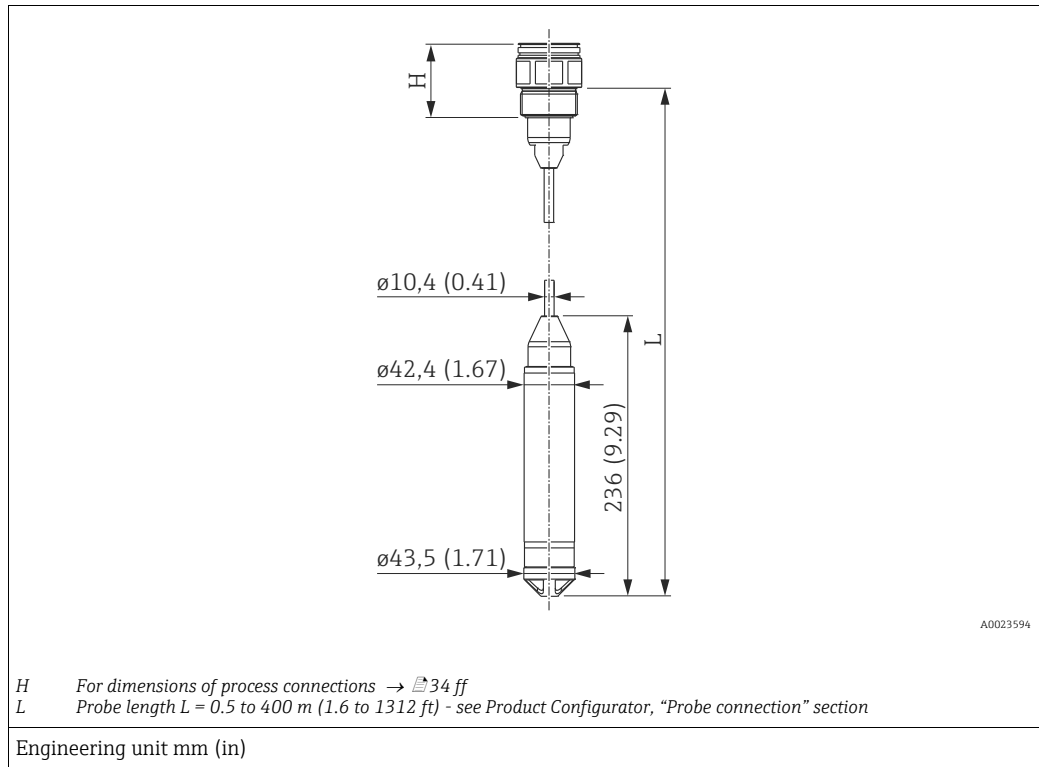

Process connection incl. sensor	Weight
Housing weight	→ 34 ff
Process connection weight	→ 35 ff
PE cable	0.13 kg/m (0.28 lbs/3.3 ft)
FEP cable	0.18 kg/m (0.40 lbs/3.3 ft)
Threaded connection incl. measuring cell tube and sensor	1.65 kg (3.64 lbs)
Flange connection incl. measuring cell tube and sensor, without a flange	-
Total weight of device	

EN/DIN, ANSI and JIS flanges

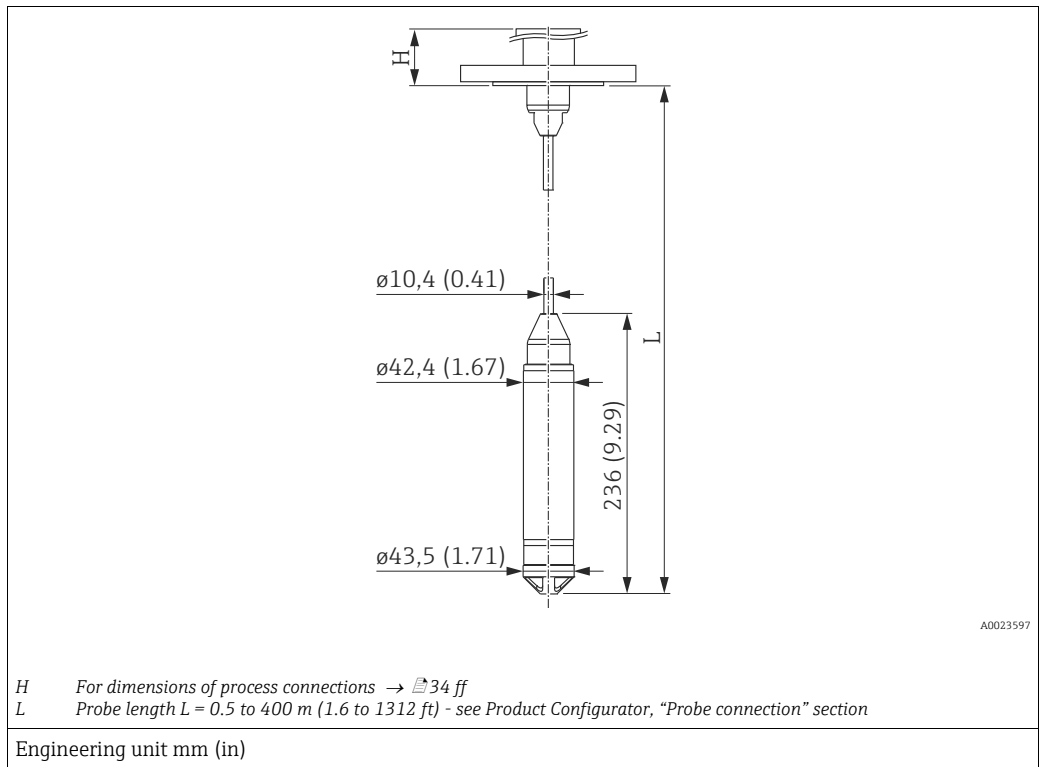

Process connection incl. sensor	Weight
Housing weight	→ 34 ff
Process connection weight	→ 35 ff
PE cable	0.13 kg/m (0.28 lbs/3.3 ft)
FEP cable	0.18 kg/m (0.40 lbs/3.3 ft)
Flange connection incl. measuring cell tube and sensor, without a flange	1.3 kg (2.87 lbs)
Total weight of device	

**Dimensions of FMB53 with F31 housing, suspension clamp and mounting bracket**

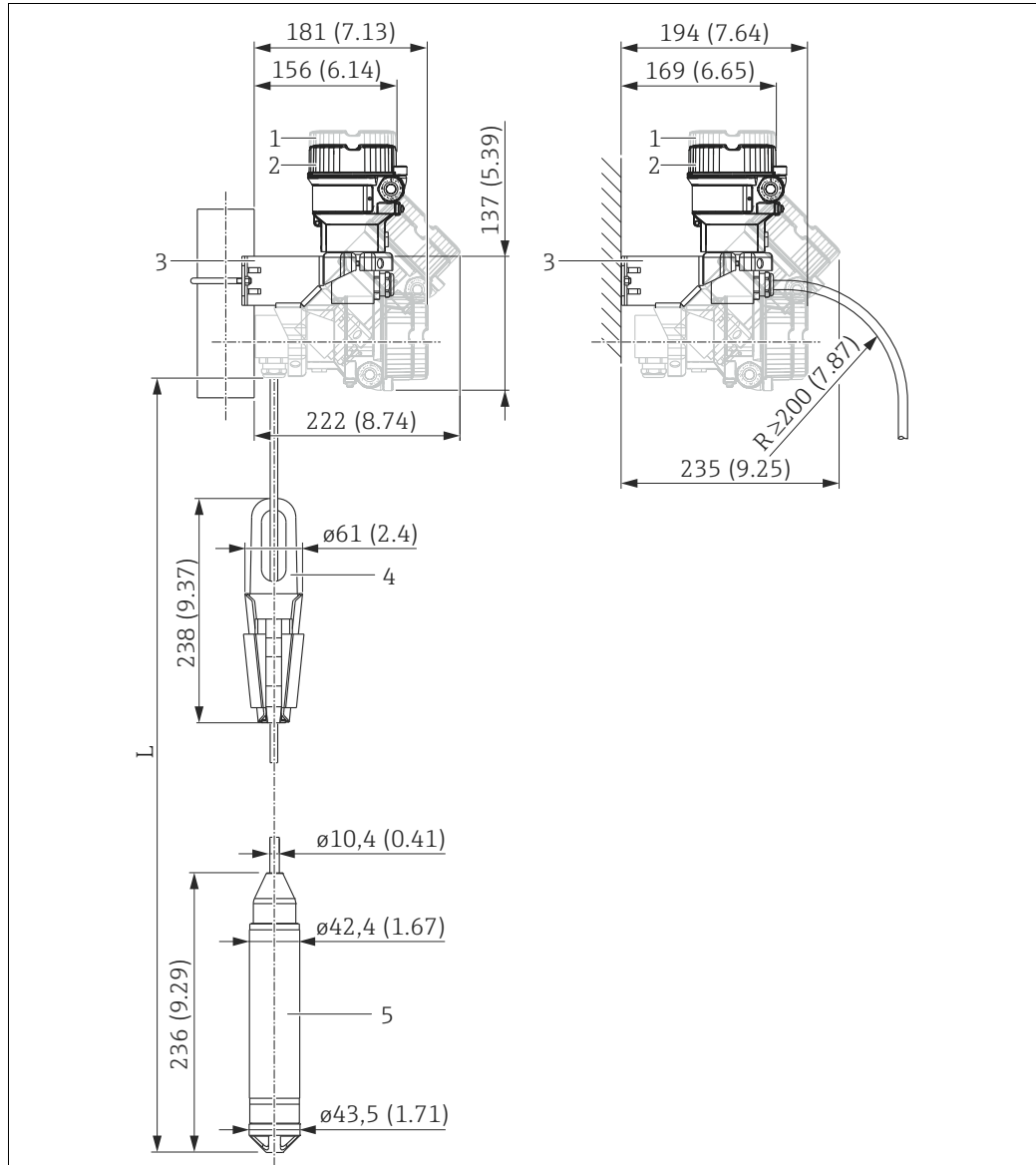

A0023598

FMB53 with suspension clamp and mounting bracket (mounting bracket without marine approval)

- 1 Dimensions for housing covers with a viewing window.
- 2 Housing covers without a viewing window are approx. 15 mm (0.59 in) lower.
- 3 Mounting bracket for pipe and wall mounting (for pipes from 1 ¼" up to 2" diameter)
- 4 Suspension clamp
- 5 Measuring cell tube
- L Probe length = 0.5 to 400 m (1.6 to 1312 ft) - see Product Configurator, "Probe connection" section

Engineering unit mm (in)

Process connection incl. sensor	Weight
Housing weight	→ 34 ff
PE cable (cable length > 120 m (394 ft) = Delivery on cable reel)	0.13 kg/m (0.28 lbs/3.3 ft)
FEP cable (cable length > 120 m (394 ft) = Delivery on cable reel)	0.18 kg/m (0.40 lbs/3.3 ft)
Mounting bracket	0.2 kg (0.44 lbs)
Pipe bend incl. cable entry	0.65 kg (1.43 lbs)
Suspension clamp	0.4 kg (0.88 lbs)
Measuring cell tube incl. sensor	1.0 kg (2.21 lbs)
Total weight of device	

**Dimensions of FMB53 with F15 housing, suspension clamp and mounting bracket**

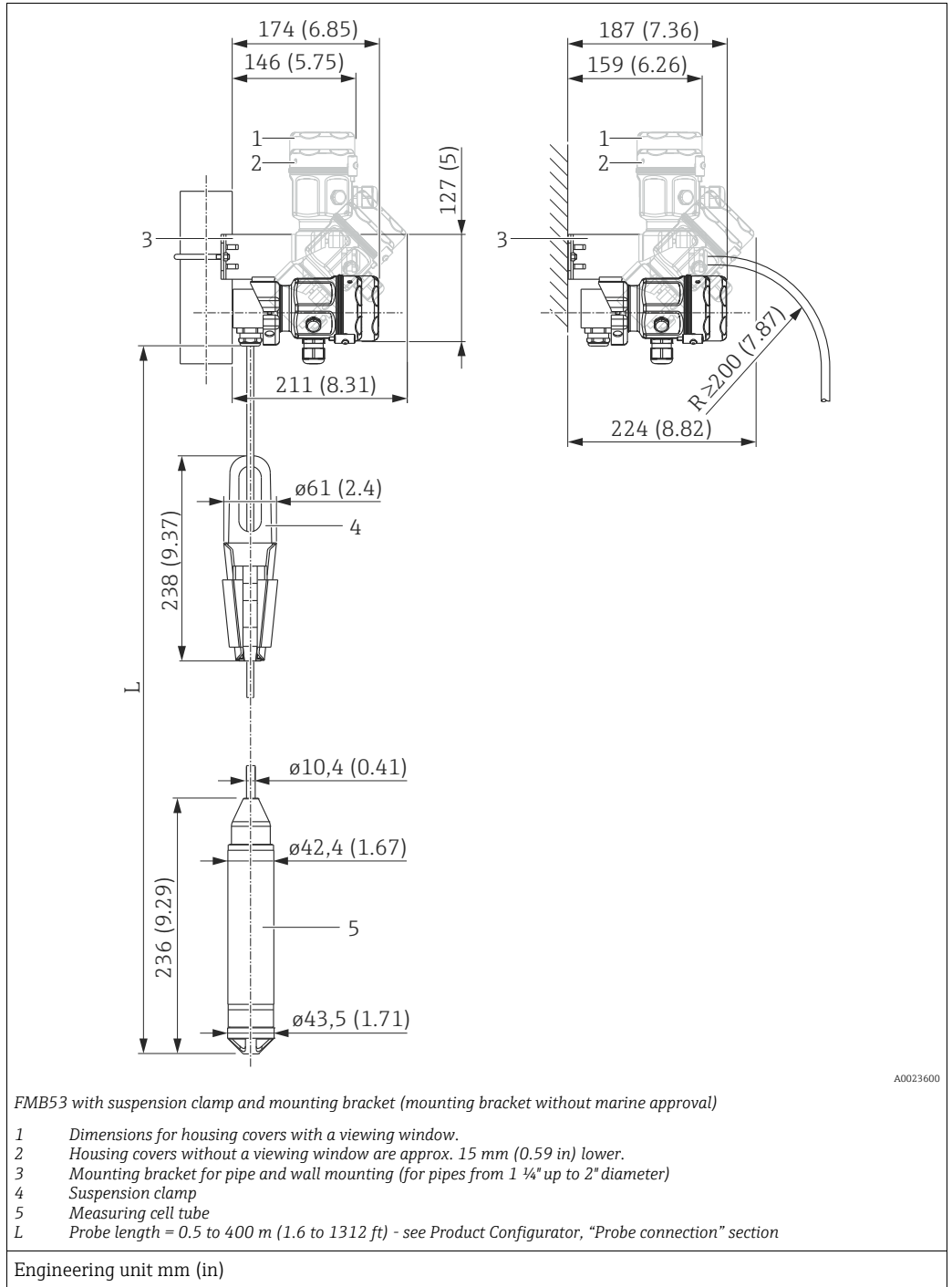

Process connection incl. sensor	Weight
Housing weight	→ 34 ff
PE cable (cable length > 120 m (394 ft) = Delivery on cable reel)	0.13 kg/m (0.28 lbs/3.3 ft)
FEP cable (cable length > 120 m (394 ft) = Delivery on cable reel)	0.18 kg/m (0.40 lbs/3.3 ft)
Mounting bracket	0.2 kg (0.44 lbs)
Pipe bend incl. cable entry	0.65 kg (1.43 lbs)
Suspension clamp	0.4 kg (0.88 lbs)
Measuring cell tube incl. sensor	1.0 kg (2.21 lbs)
<b>Total weight of device</b>	

Wall and pipe mounting with  
"Separate housing" version

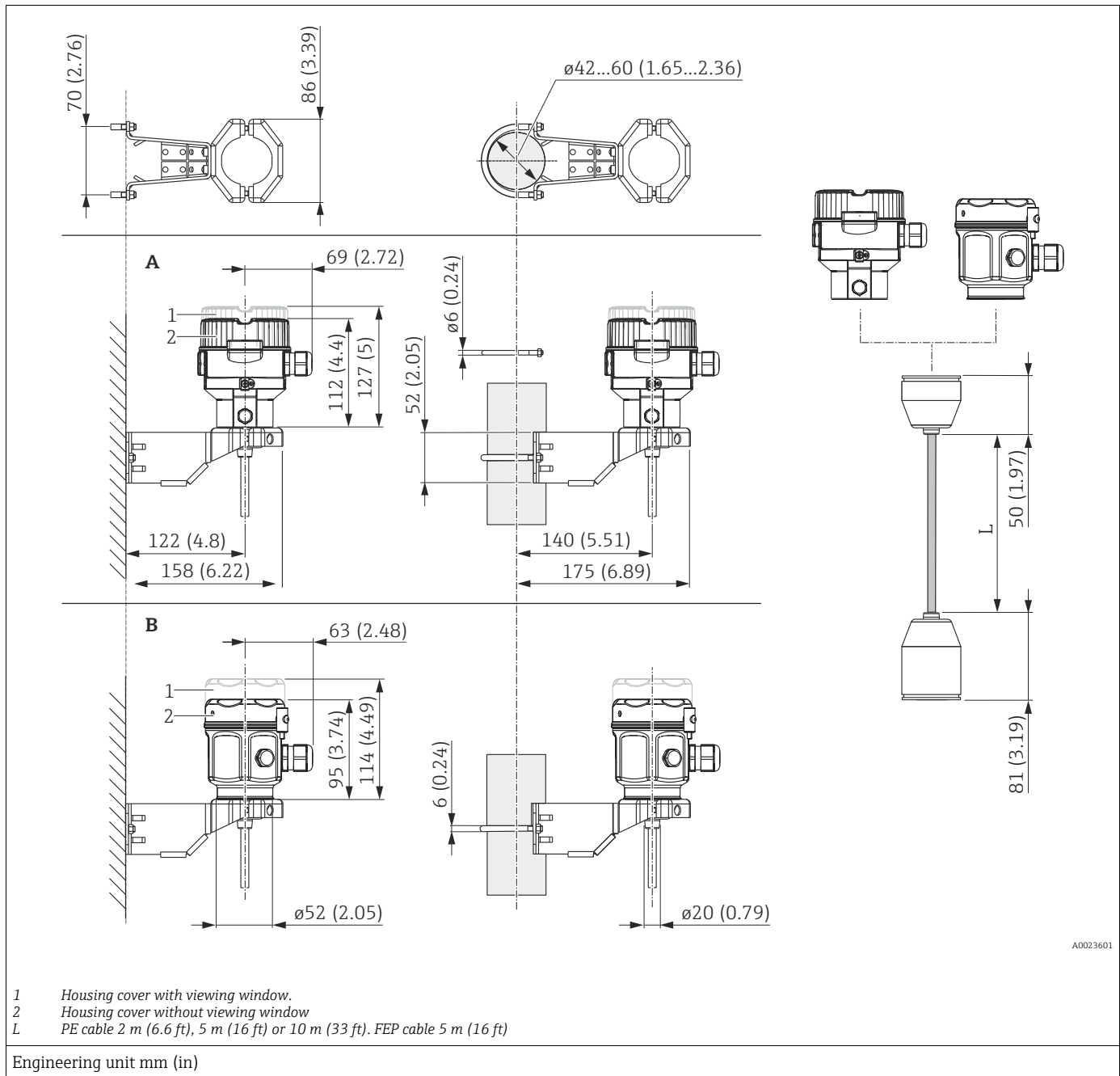

Item	Designation	Weight		Option <sup>1)</sup>
		Housing (F31 or F15)	Mounting bracket	
A	Dimensions with F31 housing	→ 34 ff	0.5 kg (1.10)	U
B	Dimensions with F15 housing			

1) Product Configurator, "Separate housing" ordering feature

Also available for order as a separate accessory: part number 71102216



### Reduction in installation height

If the separate housing is used, the mounting height of the process connection is reduced compared to the dimensions of the standard version.

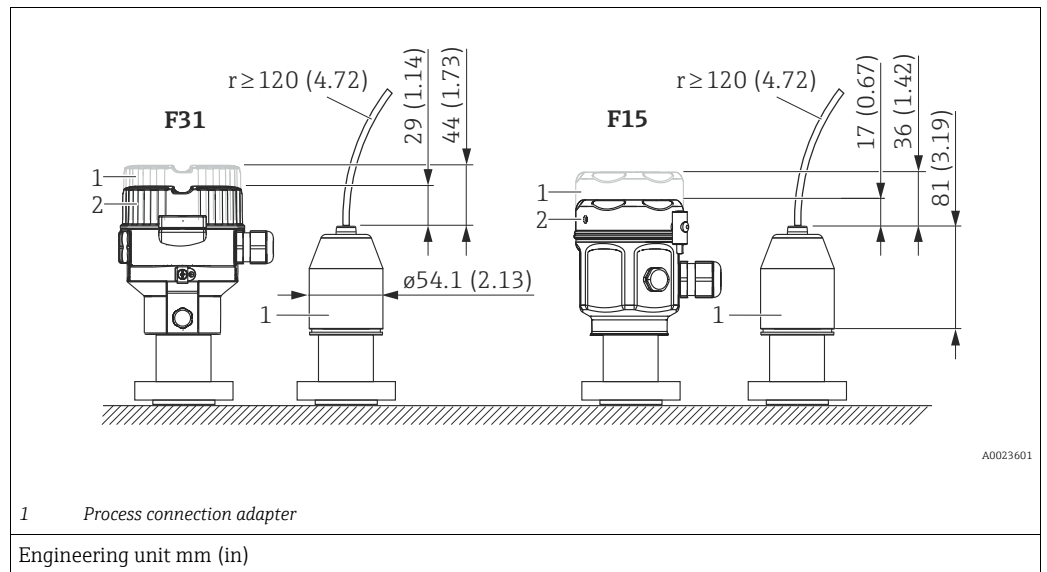

Example for a "Separate housing" version

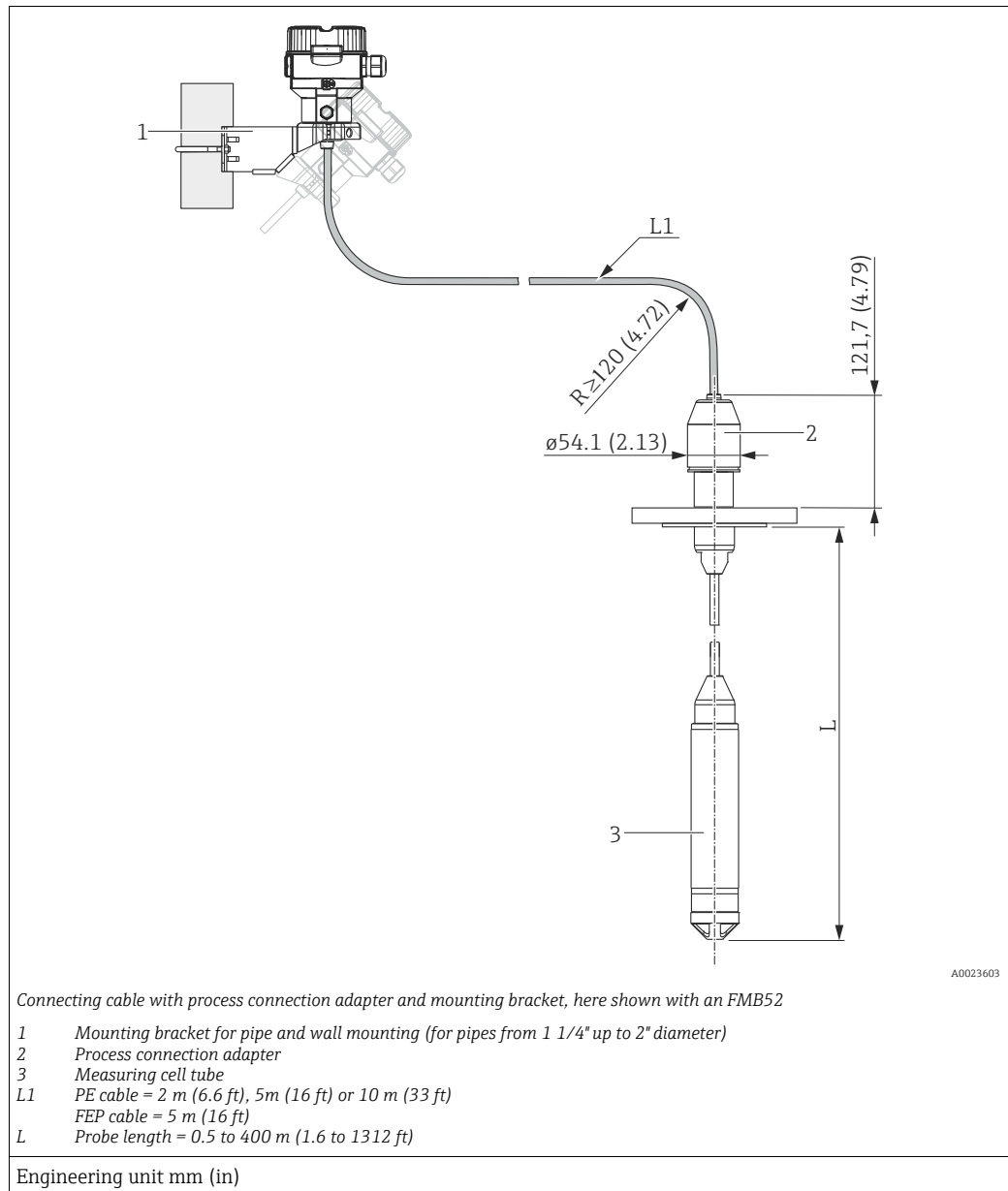

Process connection incl. sensor	Weight
Separate housing for FMB50	Weight of housing (→ 34 ff) + 0.5 kg (1.10 lbs)
Separate housing for FMB51 and FMB52	Weight of housing (→ 34 ff) + 0.65 kg (1.43 lbs)
Process connection adapter	0.4 kg (0.88 lbs)
Mounting bracket	0.2 kg (0.44 lbs)
Pipe bend incl. cable entry	0.65 kg (1.43 lbs)
PE cable 2 m (6.6 ft)	0.16 kg (0.35 lbs)
PE cable 5 m (16 ft)	0.32 kg (0.71 lbs)
Total weight of device	



Ordering information for FMB50, FMB51, FMB52: Product Configurator, "Separate housing" ordering feature

**Materials not in contact with process**     **F31 housing**

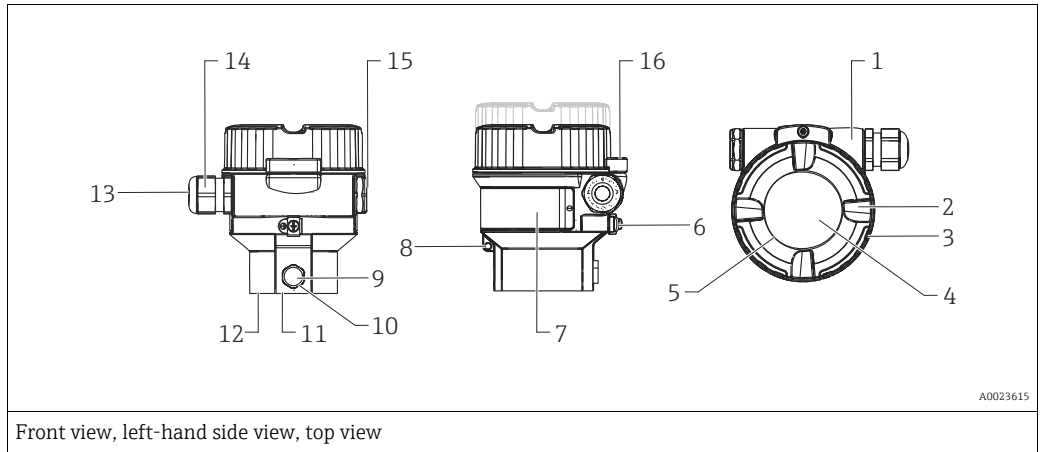

Front view, left-hand side view, top view

Item number	Component part	Material
1	F31 housing, RAL 5012 (blue)	Die-cast aluminum with protective powder-coating on polyester base
2	Cover, RAL 7035 (gray)	Die-cast aluminum with protective powder-coating on polyester base
3	Cover seal	EPDM
4	Sight glass	Mineral glass
5	Sight glass seal	Silicone (VMQ)
6	External ground terminal	AISI 304 (1.4301)
7	Nameplates	Plastic film
8	Attachment for tie-on label	AISI 304 (1.4301)/ AISI 316 (1.4401)
9	Pressure compensation filter	AISI 316L (1.4404) and PBT-FR
10	Pressure compensation filter, O-ring	VMQ or EPDM
11	Sealing ring	EPDM
12	Snap ring	PC Plastic
13	Seal of cable gland and blind plug	EPDM/NBR
14	Cable gland	Polyamide (PA), for dust ignition-proof: CuZn nickel-plated
15	Blind plug	PBT-GF30 FR for dust ignition-proof, Ex d, FM XP and CSA XP: AISI 316L (1.4435)
16	Cover clamp	Clamp AISI 316L (1.4435), screw A4

## F15 housing

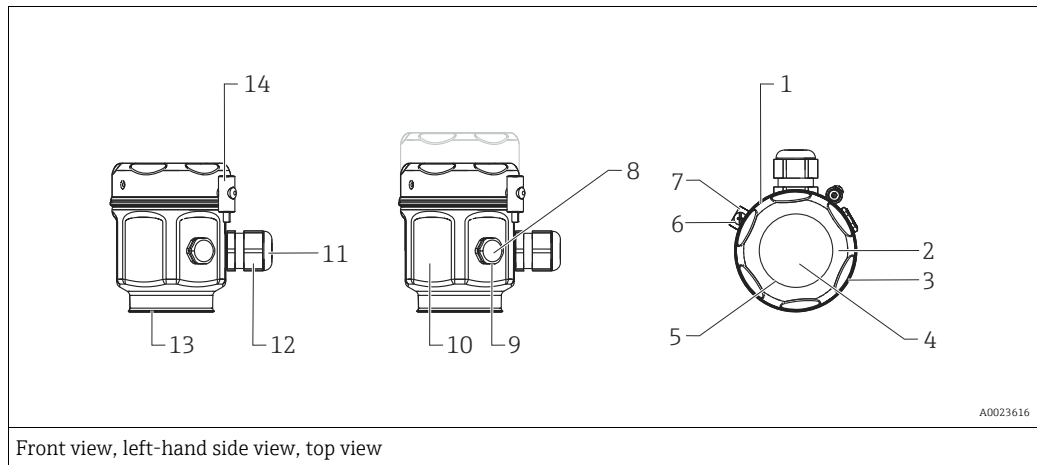

Front view, left-hand side view, top view

Item number	Component part	Material
1	F15 housing	AISI 316L (1.4404)
2	Cover	
3	Cover seal	Silicone with PTFE coating
4	Sight glass for non-hazardous area, ATEX Ex ia, NEPSI Zone 0/1 Ex ia, IECEx Zone 0/1 Ex ia, FM NI, FM IS, CSA IS	Polycarbonate (PC)
4	Sight glass for ATEX 1/2 D, ATEX 1/3 D, ATEX 1 GD, ATEX 1/2 GD, ATEX 3 G, FM DIP, CSA dust ignition-proof	Mineral glass
5	Sight glass seal	Silicone (VMQ)
6	External ground terminal	AISI 304 (1.4301)
7	Attachment for tie-on label	AISI 304 (1.4301)/ AISI 316 (1.4401)
8	Pressure compensation filter	AISI 316L (1.4404) and PBT-FR
9	Pressure compensation filter, O-ring	VMQ or EPDM
10	Nameplates	lasered
11	Cable gland	Polyamide (PA), for dust ignition-proof: CuZn nickel-plated
12	Seal of cable gland and blind plug	NBR/Silicone/EPDM
13	Sealing ring	EPDM
14	Screw	A4-50

**Connecting parts**

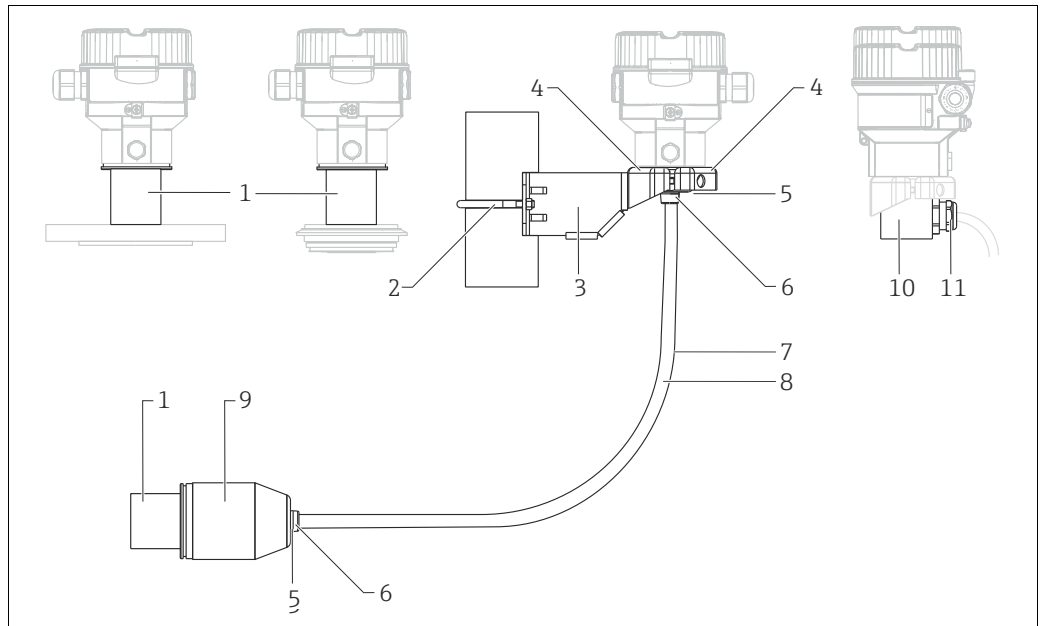

A0023617

Item number	Component part	Material
1	Connection between the housing and process connection	AISI 316L (1.4404)
2	Mounting bracket	Bracket AISI 316L (1.4404)
3		Screw and nuts A4-70
4		Half-shells: AISI 316L (1.4404)
5	Seal for cable from Separate housing	FKM, EPDM
6	Gland for cable from separate housing: Screws:	AISI 316L (1.4404) A2
7	PE cable for separate housing	Abrasion-proof cable with strain-relief Dynema members; shielded using aluminum-coated film; insulated with polyethylene (PE-LD), black; copper wires, twisted, UV-resistant
8	FEP cable for separate housing	Abrasion-proof cable; shielded using galvanized steel wire netting; insulated with fluorinated ethylene propylene (FEP), black; copper wires, twisted, UV-resistant
9	Process connection adapter for separate housing	AISI 316L (1.4404)
10	Housing adapter	FMB50, FMB51, FMB52: AISI 316L (1.4404) FMB53: AISI 304 (1.4301)
11	Cable gland: Sealing insert: O-ring:	CuZn nickel-plated TPE-V NBR

**Fill fluid**

Designation	Option <sup>1)</sup>
Inert oil	2
Synthetic oil polyalphaolefin FDA 21 CFR 178.3570, NSF H1	3

1) Product Configurator, "Fill fluid" section

**Materials in contact with the process**



The wetted device components are listed in the "Mechanical construction" (→ 34 ff) and "Ordering information" (→ 64 ff) sections.

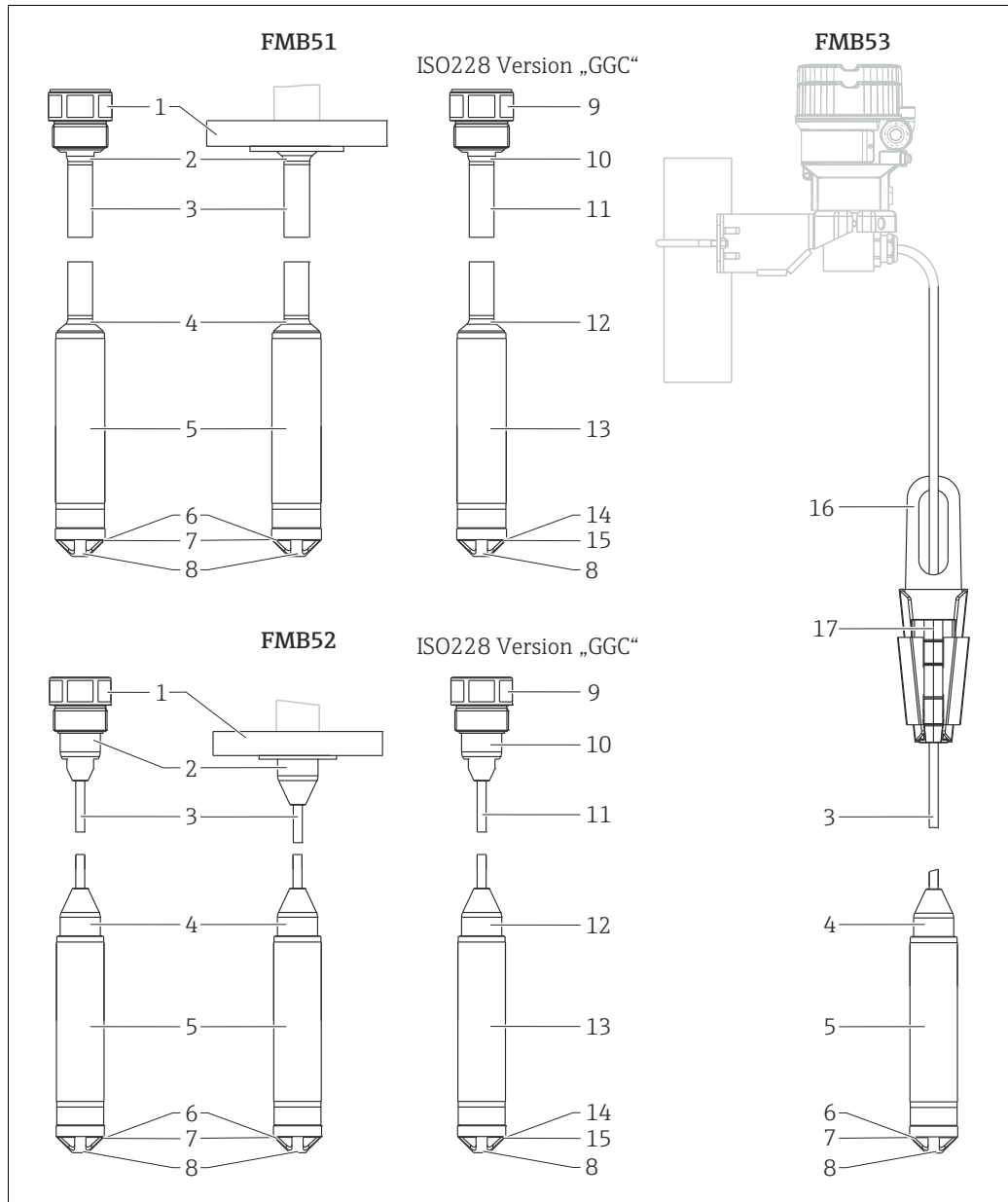

A0029619

Item number	Component part	Material
1	Process connection	→ 34 ff
2	Socket	AISI 316L (1.4404)

Item number	Component part	Material
3	Rod	AISI 316L (1.4435)
	PE cable	Abrasion-proof cable; shielded using galvanized steel wire netting and aluminum-coated film; insulated with polyethylene (PE-LD), black/blue; copper wires, twisted, UV-resistant
	PE cable (Usage in drinking water)	Abrasion-proof cable; shielded using galvanized steel wire netting and aluminum-coated film; insulated with polyethylene (PE-LD), black; copper wires, twisted, UV-resistant
	FEP cable	Abrasion-proof cable; shielded using galvanized steel wire netting and aluminum-coated film; insulated with fluorinated ethylene propylene (FEP), black; copper wires, twisted, UV-resistant
4	Socket	AISI 316L (1.4404)
5	Probe tube	AISI 316L (1.4404)

Item number	Component part	Material
6	Process isolating diaphragm and meter body	→ 64 ff
7	Seals	→ 64 ff
8	Protection cap	PPO
9	Process connection	Alloy C276 (2.4819)
10	Socket	Alloy C4 (2.4610)
11	Rod	Alloy C4 (2.4610)
12	Socket	Alloy C4 (2.4610)
13	Probe tube	Alloy C22 (2.4602)
14	Process isolating diaphragm and meter body	→ 64 ff
15	Seals	→ 64 ff
16	Suspension clamp	AISI 316L (1.4404)
17	Clamping jaw	PA-GF

### DIN/EN flanges

Endress+Hauser supplies DIN/EN flanges made of stainless steel AISI 316L as per material numbers 1.4435 or 1.4404. With regard to their stability-temperature property, the materials 1.4435 and 1.4404 are grouped together under 13EO in EN 1092-1 Tab. 18. The chemical composition of the two materials can be identical.

### Process isolating diaphragm

Material	Option <sup>1)</sup>
Alloy C	B
Rhodium>Gold>AlloyC	L
Platinum>Gold>AlloyC (not FMB50)	N

- 1) Product Configurator, "Material of process isolating diaphragm" ordering feature

**Seals**

<b>Designation</b>	<b>Option <sup>1)</sup></b>
FKM Viton	A <sup>2)</sup>
EPDM	J <sup>2)</sup>
Kalrez 6375	L <sup>2)</sup>
None, welded cell	U

- 1) Product Configurator, "Seal" ordering feature  
 2) Not FMB50

**TSE Certificate of Suitability (Transmissible Spongiform Encephalopathy)**

The following applies to all process wetted device components:

- They do not contain any materials derived from animals.
- No auxiliaries or operating materials derived from animals are used in production or processing.



## Operability

### Operating concept

#### Operator-oriented menu structure for user-specific tasks

- Commissioning
- Operation
- Diagnostics
- Expert level

#### Quick and safe commissioning

Guided menus for applications

#### Reliable operation

- Onsite operation possible in several languages
- Standardized operation at the device and in the operating tools
- Parameters relating to measured values can be locked/unlocked using the device's write protection switch, using the device software or via remote control.

#### Efficient diagnostics increase measurement availability

- Remedial measures are integrated in plain text
- Diverse simulation options

### Onsite operation

#### Local display (optional)

A 4-line liquid crystal display (LCD) is used for display and operation. The local display shows measured values, dialog texts as well as fault and notice messages in plain text, thereby supporting the user at every stage of operation. The liquid crystal display of the device can be turned in 90° stages. Depending on the orientation of the device, this makes it easy to operate the device and read the measured values.

Functions:

- 8-digit measured value display including sign and decimal point, bar graph for 4 to 20 mA HART as current display; or for PROFIBUS PA as graphic display of the standardized value of the AI Block; for FOUNDATION Fieldbus as graphic display of the transducer output in relation to the set pressure range.
- Simple and complete menu guidance as parameters are split into several levels and groups
- Each parameter is given a 3-digit ID number for easy navigation
- Possibility of configuring the display to suit individual requirements and preferences, such as language, alternating display, contrast setting, display of other measured values such as sensor temperature etc.
- Comprehensive diagnostic functions (fault and warning message etc.)

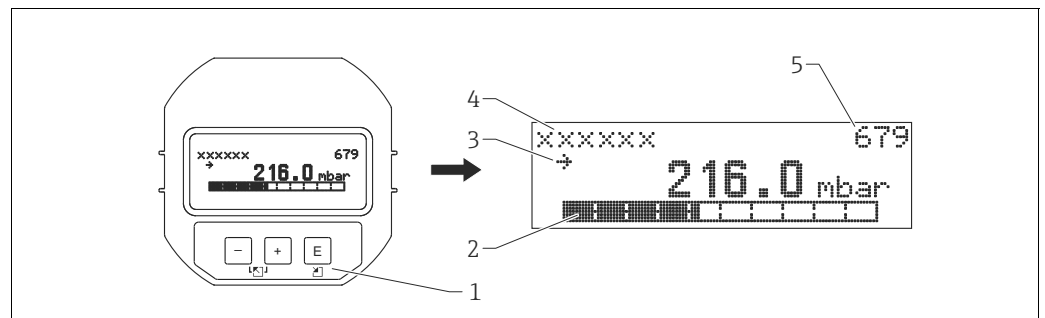

- 1 Operating keys
- 2 Bar graph
- 3 Symbol
- 4 Header
- 5 Parameter ID number

Ordering information:

Product Configurator, "Output; operation" ordering feature

Function	Operation via display		
	HART	PROFIBUS PA	FOUNDATION Fieldbus
Position adjustment (zero point correction)	✓	✓	✓
Setting lower range value and upper range value - reference pressure present at the device	✓	✓	✓
Device reset	✓	✓	✓
Locking and unlocking parameters relevant to the measured value	✓	✓	✓
Value acceptance indicated by the green LED	—	—	—
Switching damping on and off	✓	✓	✓

Operating keys and elements located on the electronic insert

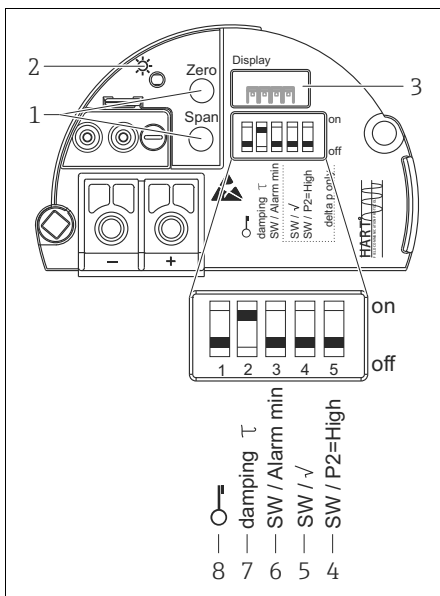

A0023125

HART electronic insert

- 1 Operating keys for lower range value (zero) and upper range value (span)
- 2 Green LED to indicate successful operation
- 3 Slot for optional local display
- 4 DIP switch only for Deltabar M
- 5 DIP switch only for Deltabar M
- 6 DIP switch for alarm current SW / Alarm Min (3.6 mA)
- 7 DIP switch for switching damping on/off
- 8 DIP switch for locking/unlocking parameters relevant to the measured value

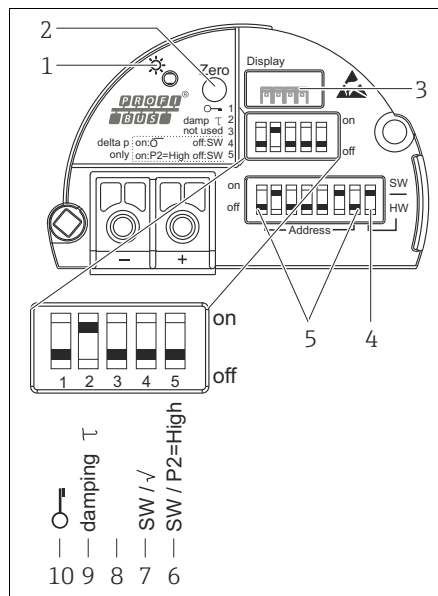

A0023126

PROFIBUS PA electronic insert

- 1 Green LED to indicate successful operation
- 2 Operating key for position zero adjustment or reset (Zero)
- 3 Slot for optional local display
- 4 DIP switch for bus address SW / HW
- 5 DIP switch for hardware address
- 6 DIP switch only for Deltabar M
- 7 DIP switch only for Deltabar M
- 8 Not used
- 9 DIP switch for switching damping on/off
- 10 DIP switch for locking/unlocking parameters relevant to the measured value

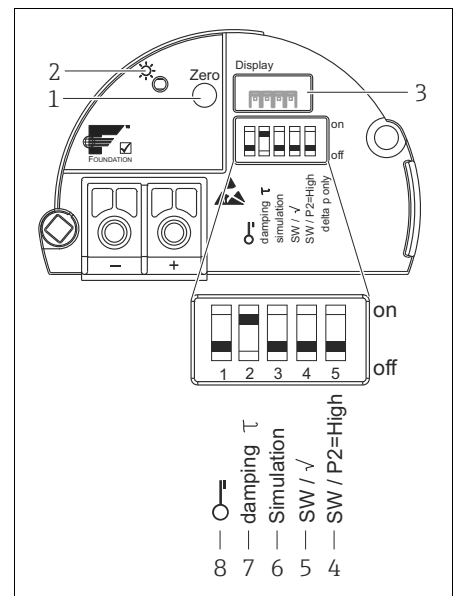

A0023127

FOUNDATION Fieldbus electronic insert

- 1 Operating key for position zero adjustment or reset (Zero)
- 2 Green LED to indicate successful operation
- 3 Slot for optional local display
- 4 DIP switch only for Deltabar M
- 5 DIP switch only for Deltabar M
- 6 DIP switch for simulation mode
- 7 DIP switch for switching damping on/off
- 8 DIP switch for locking/unlocking parameters relevant to the measured value

Function	Operation with operating keys and elements on the electronic insert		
	HART	PROFIBUS PA	FOUNDATION Fieldbus
Position adjustment (zero point correction)	✓	✓	✓
Setting lower range value and upper range value - reference pressure present at the device	✓	—	—
Device reset	✓	✓	✓
Locking and unlocking parameters relevant to the measured value	✓	✓	✓
Value acceptance indicated by the green LED	✓	✓	✓
Switching damping on and off	✓	✓	✓

Ordering information:  
Product Configurator, "Display, operation" ordering feature

## Operating languages

You can also choose another language in addition to the standard language "English":

Designation	Option <sup>1)</sup>
English	AA
German	AB
French	AC
Spanish	AD
Italian	AE
Dutch	AF
Chinese	AK
Japanese	AL

1) Product Configurator, "Additional operating language" ordering feature

## Remote operation

All software parameters are accessible depending on the position of the write protection switch on the device.

Hardware and software for remote operation	HART	PROFIBUS PA	FOUNDATION Fieldbus
FieldCare → 59 ff	✓ <sup>1)</sup>	✓ <sup>2)</sup>	✓
FieldXpert SFX100 → 59 ff	✓	—	✓
NI-FBUS Configurator → 60 ff	—	—	✓

1) Commubox FXA195 required → 60 ff

2) Profiboard or Proficard required → 60 ff

### FieldCare

FieldCare is an Endress+Hauser asset management tool based on FDT technology. With FieldCare, you can configure all Endress+Hauser devices as well as devices from other manufacturers that support the FDT standard.

FieldCare supports the following functions:

- Configuration of transmitters in offline and online mode
- Loading and saving device data (upload/download)
- HistoROM<sup>®</sup>/M-DAT analysis
- Documentation of the measuring point

Connection options:

- HART via Commubox FXA195 and the USB port on a computer
- PROFIBUS PA via segment coupler and PROFIBUS interface card
- Service interface with Commubox FXA291 and ToF adapter FXA291 (USB).

For further information please contact your local Endress+Hauser Sales Center.

### Field Xpert SFX100

Field Xpert is an industrial PDA with integrated 3.5" touchscreen from Endress+Hauser based on Windows Mobile. It offers wireless communication via the optional VIATOR Bluetooth modem or via WiFi and Endress+Hauser's Fieldgate FXA520. Field Xpert also works as a stand-alone device for asset management applications. For details refer to BA00060S/04/EN.

**Commubox FXA195**

For intrinsically safe HART communication with FieldCare via the USB interface. For details refer to TI00404F/00/EN.

**Commubox FXA291**

The Commubox FXA291 connects Endress+Hauser field devices with a CDI interface (= Endress+Hauser Common Data Interface) and the USB port of a computer or laptop. For details, see TI00405C/07/EN.



For the following Endress+Hauser devices, you also need the "ToF adapter FXA291" accessory:

- Cerabar S PMC71, PMP7x
- Deltabar S PMD7x, FMD7x
- Deltapilot S FMB70

**ToF adapter FXA291**

The ToF adapter FXA291 connects the Commubox FXA291 to devices in the ToF platform, pressure devices and Gammapilot via the USB port of a computer or laptop. For details, see KA00271F.

**Profiboard**

For connecting a PC to PROFIBUS.

**Proficard**

For connecting a laptop to PROFIBUS.

**FF configuration program**

FF configuration program, such as NI-FBUS Configurator, to

- connect devices with "FOUNDATION Fieldbus signal" into an FF-network
- set FF-specific parameters

Remote operation via:

- Operation with NI-FBUS Configurator:
  - The NI-FBUS Configurator is an easy-to-use graphical environment for creating linkages, loops, and a schedule based on the fieldbus concepts.
  - You can use the NI-FBUS Configurator to configure a fieldbus network as follows:
    - Set block and device tags
    - Set device addresses
    - Create and edit function block control strategies (function block applications)
    - Configure vendor-defined function and transducer blocks
    - Create and edit schedules
    - Read and write to function block control strategies (function block applications)
    - Invoke Device Description (DD) methods
    - Display DD menus
    - Download a configuration
    - Verify a configuration and compare it to a saved configuration
    - Monitor a downloaded configuration
    - Replace a virtual device by a real device
    - Save and print a configuration





**System integration**

The device can be given a tag name (max. 8 alphanumeric characters).

Designation	Option <sup>1)</sup>
Measuring point (TAG), see additional specifications	Z1
Bus address, see additional specifications	Z2

1) Product Configurator, "Identification" ordering feature

## Certificates and approvals

<b>CE mark</b>	The device meets the legal requirements of the relevant EC directives. Endress+Hauser confirms that the device has been successfully tested by applying the CE mark.
<b>C-tick symbol</b>	The measuring system complies with the EMC requirements of the "Australian Communications and Media Authority (ACMA)".
<b>Ex approvals</b>	<ul style="list-style-type: none"> <li>▪ ATEX</li> <li>▪ FM</li> <li>▪ CSA</li> <li>▪ Also combinations of different approvals</li> </ul> <p>All explosion protection data are given in separate documentation which is available upon request. The Ex documentation is supplied as standard with all devices approved for use in explosion hazardous areas. →  68 ff, "Safety Instructions" and "Installation/Control Drawings" ordering features.</p>
<b>Suitability for hygienic processes</b>	<p>All materials in contact with foodstuffs comply with framework Regulation (EC) 1935/2004. The Deltapilot is available with hygienic process connections (overview: see order code).</p> <p><b>▲ CAUTION</b> <b>Contamination in the process!</b> Risk of contamination if incorrect seals and parts are used!</p> <ul style="list-style-type: none"> <li>▶ To avoid the risk of contamination, when installing the device comply with the design principles of EHEDG, Guideline 37 "Hygienic Design and Application of Sensors" and Guideline 16 "Hygienic Pipe Couplings".</li> <li>▶ Suitable assemblies and seals must be used to ensure hygienic design in accordance with 3-A SSI and EHEDG specifications.</li> <li>▶ The leak-proof connections can be cleaned with the cleaning methods typical of this industry (CIP and SIP). Attention must be paid to the pressure and temperature specifications of the sensor and process connections for CIP and SIP processes (clean in place/sterilize in place).</li> </ul>
<div style="display: flex; justify-content: space-around; align-items: center;"> <div style="text-align: center;">  <p>A0024005</p> </div> <div style="text-align: center;">  <p>A0020029</p> </div> </div>	
<div style="text-align: center;">  <p>Gap-free connections can be cleaned without residue using the usual cleaning methods.</p> </div>	
<b>Pharma (CoC) (FMB50 only)</b>	<p><b>Certificate of Compliance (CoC) (according to ASME BPE-2007)</b></p> <p>Ordering information: Product Configurator, "Additional options 1" ordering feature, option "LW"</p>
<b>Functional safety SIL</b>	<p>The Deltapilot M with 4 to 20 mA output signal has been developed to assessed and certified by TÜV NORD CERT as per IEC 61508 Edition 2.0 and IEC 61511. These devices can be used to monitor the process level and pressure up to SIL 2. For a detailed description of the safety functions with Deltapilot M, settings and functional safety data, see the "Functional safety manual - Deltapilot M" SD00347P.</p> <p>Ordering information: Product Configurator, "Additional approval:" ordering feature, option "LA".</p>

**Overfill protection** WHG (FMB50, FMB51, FMB52): see document ZE00275P

Ordering information:  
Product Configurator, "Additional approval" ordering feature, option "LC".

**AD2000** The pressure retaining material 316L (1.4435/1.4404) corresponds to AD2000 - W2/W10.

**Pressure Equipment Directive (PED)** The Deltapilot M device corresponds to Article 3 (3) of the EC directive 97/23/EC (Pressure Equipment Directive) and has been designed and manufactured according to good engineering practice.

**Marine approval**

Designation	FMB50	FMB51	FMB52	FMB53	Option <sup>1)</sup>
GL	✓	✓	–	✓	LE
ABS	✓	✓	–	✓	LF
LR	✓	✓	–	✓	LG
BV	✓	✓	–	✓	LH
DNV	✓	✓	–	✓	LI

1) Product Configurator, "Additional options 1" and "Additional options 2" ordering feature

**Other standards and guidelines**

DIN EN 60770 (IEC 60770):  
Transmitters for use in industrial process control systems  
Part 1: Methods for inspection and routine testing

DIN 16086:  
Electrical pressure measuring instruments, pressure sensors, pressure transmitters, pressure measuring instruments, concepts, specifications on data sheets

EN 61326 series:  
EMC product family standard for electrical equipment for measurement, control and laboratory use.

**Drinking water approval**

Designation	Option <sup>1)</sup>
KTW	LQ
NSF61	LR
ACS (under development)	LS

1) Product Configurator, "Additional options 1" and "Additional options 2" ordering feature

**Classification of process sealing between electrical systems and (flammable or combustible) process fluids in accordance with ANSI/ISA 12.27.01**

Endress+Hauser instruments are designed according to ANSI/ISA 12.27.01 either as single seal or dual seal devices with annunciation, allowing the user to waive the use and save the cost of installing external secondary process seals in the conduit as required by the process sealing sections of ANSI/NFPA 70 (NEC) and CSA 22.1 (CEC). These instruments comply with the North-American installation practice and provide a very safe and cost-saving installation for pressurized applications with hazardous fluids.

Further information can be found in the control drawings of the relevant devices.

**Inspection certificate**

Designation	FMB50	FMB51	FMB52	FMB53	Option <sup>1)</sup>
3.1 Material certificate, wetted metallic parts, EN10204-3.1 inspection certificate	✓	✓	✓	✓	JA
Conformity to NACE MR0175, wetted metallic parts	✓	✓	✓	✓	JB
Conformity to NACE MR0103, wetted metallic parts	✓	✓	✓	✓	JE
Conformity to AD2000, wetted metallic parts, excepting process membrane	✓	–	–	–	JF
Surface finish measurement ISO4287/Ra, wetted metallic parts, Inspection certificate	✓	–	–	–	KB

Designation	FMB50	FMB51	FMB52	FMB53	Option <sup>1)</sup>
Helium leak test, internal procedure, inspection certificate	✓	✓	✓	✓	KD
Pressure test, internal procedure, inspection certificate	✓	✓	✓	–	KE
3.1 Material certificate+Delta-Ferrit measurement, internal procedure, wetted metallic parts, EN10204-3.1 inspection certificate	✓	–	–	–	KF
3.1 Material certificate+PMI test (XRF), internal procedure, wetted metallic parts, EN10204-3.1 inspection certificate	✓	✓	✓	✓	KG

1) Product Configurator, "Test, certificate" ordering feature

### Calibration; unit

Designation	Option <sup>1)</sup>
Sensor range; %	A
Sensor range; mbar/bar	B
Sensor range; kPa/MPa	C
Sensor range; mm/mH <sub>2</sub> O	D
Sensor range; inH <sub>2</sub> O/ftH <sub>2</sub> O	E
Sensor range; psi	F
Customized pressure; see additional specification	J
Customized level; see additional specification	K

1) Product Configurator, "Calibration; unit" ordering feature

### Calibration

Designation	Option <sup>1)</sup>
Factory calibration, 5-point	F1
DKD/DAkkS calibration certificate 10-point <sup>2)</sup>	F2

1) Product Configurator, "Calibration" ordering feature

2) Only for FMB50

### Service

Designation	Option <sup>1)</sup>
Oil and grease removed <sup>2)</sup>	HA
Cleaned for oxygen service <sup>2)</sup>	HB
Cleaned from PWIS (PWIS = paint wetting impairment substances) <sup>2)</sup>	HC
Configured min alarm current	IA
Configured HART Burst Mode PV	IB

1) Product Configurator, "Service" ordering feature

2) Only device, not accessory or enclosed accessory

## Ordering information

Detailed ordering information is available from the following sources:

- In the Product Configurator on the Endress+Hauser website: [www.endress.com](http://www.endress.com) → Select country → Products → Select product → Product page function: Configure this product
- From your Endress+Hauser Sales Center: [www.endress.com/worldwide](http://www.endress.com/worldwide)



### Product Configurator - the tool for individual product configuration

- Up-to-the-minute configuration data
- Depending on the device: direct input of information specific to measuring point, such as measuring range or operating language
- Automatic verification of exclusion criteria
- Automatic creation of the order code and its breakdown in PDF or Excel output format
- Ability to order directly in the Endress+Hauser Online Shop

## Configuration data sheet

### Pressure

The following configuration data sheet has to be filled in and included with the order if the option J - Customized pressure has been selected in feature 90 "Calibration; unit" in the ordering information.

Pressure Engineering Unit	
<input type="checkbox"/> mbar	<input type="checkbox"/> mmH <sub>2</sub> O
<input type="checkbox"/> bar	<input type="checkbox"/> mH <sub>2</sub> O
<input type="checkbox"/> psi	<input type="checkbox"/> inH <sub>2</sub> O
<input type="checkbox"/> mmHg	<input type="checkbox"/> Pa
<input type="checkbox"/> ftH <sub>2</sub> O	<input type="checkbox"/> kgf/cm <sup>2</sup>
<input type="checkbox"/> kPa	<input type="checkbox"/> MPa
Calibration Range / Output	
Low range value (LRV): _____	[pressure engineering unit]
Upper range value (URV): _____	[pressure engineering unit]
Display Information	
1st Value Display <sup>1)</sup>	2nd Value Display <sup>1)</sup>
<input type="checkbox"/> Main Value	<input type="checkbox"/> none (Default)
	<input type="checkbox"/> Main Value [%]
	<input type="checkbox"/> Pressure
	<input type="checkbox"/> Current [mA] (HART only)
	<input type="checkbox"/> Temperature
<sup>1)</sup> Depending on sensor and communication variant	
Damping	
Damping: _____ sec	(Default 2 sec)



**Level**

The following configuration data sheet has to be filled in and included with the order if the option K - Customized level has been selected in feature 90 "Calibration; unit" in the ordering information.

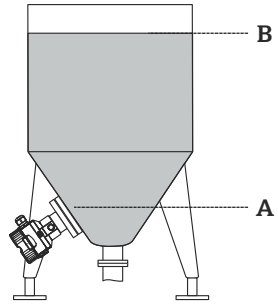
Pressure Engineering Unit	Output Unit (Scaled unit)																																			
<input type="checkbox"/> mbar <input type="checkbox"/> mmH <sub>2</sub> O <input type="checkbox"/> mmHg <input type="checkbox"/> Pas <input type="checkbox"/> bar <input type="checkbox"/> mH <sub>2</sub> O <input type="checkbox"/> kgf/cm <sup>2</sup> <input type="checkbox"/> kPa <input type="checkbox"/> psi <input type="checkbox"/> inH <sub>2</sub> O <input type="checkbox"/> MPa	<table style="width: 100%; border-collapse: collapse;"> <thead> <tr style="border-bottom: 1px solid black;"> <th style="width: 20%;">Mass</th> <th style="width: 20%;">Length</th> <th style="width: 20%;">Volume</th> <th style="width: 20%;">Volume</th> <th style="width: 20%;">Percent</th> </tr> </thead> <tbody> <tr> <td><input type="checkbox"/> kg</td> <td><input type="checkbox"/> m</td> <td><input type="checkbox"/> l</td> <td><input type="checkbox"/> gal</td> <td><input type="checkbox"/> %</td> </tr> <tr> <td><input type="checkbox"/> t</td> <td><input type="checkbox"/> dm</td> <td><input type="checkbox"/> hl</td> <td><input type="checkbox"/> lgal</td> <td></td> </tr> <tr> <td><input type="checkbox"/> lb</td> <td><input type="checkbox"/> cm</td> <td><input type="checkbox"/> m<sup>3</sup></td> <td></td> <td></td> </tr> <tr> <td></td> <td><input type="checkbox"/> mm</td> <td><input type="checkbox"/> ft<sup>3</sup></td> <td></td> <td></td> </tr> <tr> <td></td> <td><input type="checkbox"/> ft</td> <td><input type="checkbox"/> in<sup>3</sup></td> <td></td> <td></td> </tr> <tr> <td></td> <td><input type="checkbox"/> inch</td> <td></td> <td></td> <td></td> </tr> </tbody> </table>	Mass	Length	Volume	Volume	Percent	<input type="checkbox"/> kg	<input type="checkbox"/> m	<input type="checkbox"/> l	<input type="checkbox"/> gal	<input type="checkbox"/> %	<input type="checkbox"/> t	<input type="checkbox"/> dm	<input type="checkbox"/> hl	<input type="checkbox"/> lgal		<input type="checkbox"/> lb	<input type="checkbox"/> cm	<input type="checkbox"/> m <sup>3</sup>				<input type="checkbox"/> mm	<input type="checkbox"/> ft <sup>3</sup>				<input type="checkbox"/> ft	<input type="checkbox"/> in <sup>3</sup>				<input type="checkbox"/> inch			
Mass	Length	Volume	Volume	Percent																																
<input type="checkbox"/> kg	<input type="checkbox"/> m	<input type="checkbox"/> l	<input type="checkbox"/> gal	<input type="checkbox"/> %																																
<input type="checkbox"/> t	<input type="checkbox"/> dm	<input type="checkbox"/> hl	<input type="checkbox"/> lgal																																	
<input type="checkbox"/> lb	<input type="checkbox"/> cm	<input type="checkbox"/> m <sup>3</sup>																																		
	<input type="checkbox"/> mm	<input type="checkbox"/> ft <sup>3</sup>																																		
	<input type="checkbox"/> ft	<input type="checkbox"/> in <sup>3</sup>																																		
	<input type="checkbox"/> inch																																			
<p>Empty pressure [a]: Low pressure value (empty) _____ [pressure engineering unit]</p> <p>Full pressure [b]: High pressure value (full) _____ [pressure engineering unit]</p>	<p>Empty calibration [a]: Low level value (empty) _____ [Scaled Unit]</p> <p>Full calibration [b]: High level value (full) _____ [Scaled Unit]</p>																																			
<p><b>Example</b></p>  <p style="text-align: right; margin-right: 50px;">A0023621</p> <table style="margin-left: auto; margin-right: 0;"> <tr> <td style="padding-right: 20px;">A</td> <td>0 mbar / 0m</td> </tr> <tr> <td>B</td> <td>300 mbar (4.5psi) / 3 m (9.8 ft).</td> </tr> </table>		A	0 mbar / 0m	B	300 mbar (4.5psi) / 3 m (9.8 ft).																															
A	0 mbar / 0m																																			
B	300 mbar (4.5psi) / 3 m (9.8 ft).																																			
Display Information																																				
<p>1st Value Display <sup>1)</sup></p> <input type="checkbox"/> Main Value	<p>2nd Value Display <sup>1)</sup></p> <input type="checkbox"/> none (Default) <input type="checkbox"/> Main Value [%] <input type="checkbox"/> Pressure <input type="checkbox"/> Current [mA] (HART only) <input type="checkbox"/> Temperature																																			
<p><sup>1)</sup> Depending on sensor and communication variant</p>																																				
Damping																																				
<p>Damping: _____ sec (Default 2 sec)</p>																																				



Smallest calibratable span (preset at the factory) → 13.

---

## Accessories

---

**Suspension clamp  
(FMB53 only)**

→ 29 ff

**Extension cable shortening  
kit (FMB53 only)**

See Product Configurator, "Accessory enclosed" ordering feature, option "PW" or can be ordered as a separate accessory (part no. 71125862). For details refer to SD00553P/00/A2.

**M12 connector**

→ 23 ff

Ordering information:

Product Configurator, "Enclosed accessories" ordering feature, option "RL, RM, RN".

**Welding necks and Weld-in  
tool flanges**

See technical Information TI00426F/00.

**Adapter Uni for FMB50**

The following adapters can be used to create a connection between the customer's process connection and the Deltapilot S FMB50 with a universal adapter:

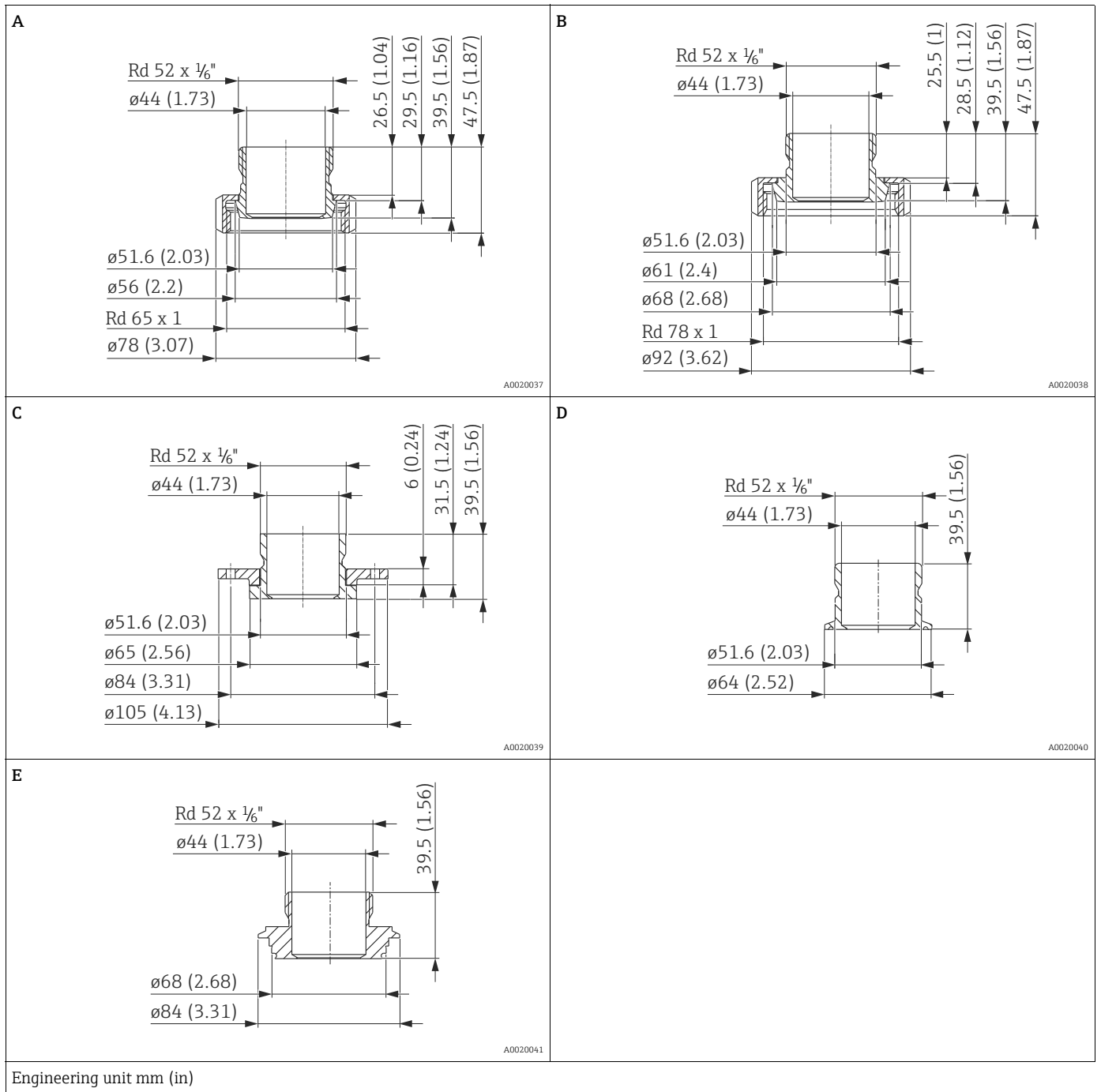

Engineering unit mm (in)

Item	Designation	Material	Weight kg (lbs)	Order number	Order number with 3.1 inspection certificate	Option <sup>1)</sup>
A	DIN11851 DN40	AISI 316L (1.4435)	0.2 (0.44)	71114172	71114178	RA / R1
B	DIN11851 DN50		0.3 (0.66)	71114173	71114205	RB / R2
C	DRD DN50		0.6 (1.32)	71114174	71114206	RC / R3
D	Clamp 2"		0.2 (0.44)	71114176	71114207	RD / R4
E	Varivent		0.5 (1.1)	71114177	71114208	RF / R6

1) Product Configurator, "Enclosed accessories" section

## Documentation

<b>Technical Information</b>	<ul style="list-style-type: none"> <li>■ EMC test procedures: TI00241F/00/EN</li> <li>■ Deltabar M: TI00434P/00/EN</li> <li>■ Cerabar M: TI00436P/00/EN</li> </ul>
<b>Operating Instructions</b>	<ul style="list-style-type: none"> <li>■ 4...20 mA HART: BA00382P/00/EN</li> <li>■ PROFIBUS PA: BA00383P/00/EN</li> <li>■ FOUNDATION Fieldbus: BA00384P/00/EN</li> </ul>
<b>Brief Operating Instructions</b>	<ul style="list-style-type: none"> <li>■ 4...20 mA HART: KA01033P/00/EN</li> <li>■ PROFIBUS PA: KA01034P/00/EN</li> <li>■ FOUNDATION Fieldbus: KA01035P/00/EN</li> </ul>
<b>Functional safety manual (SIL)</b>	Deltapilot M (4 to 20 mA): SD00347P/00/EN

### Safety Instructions

Directive	Approval	Category	Type	Electronics	Documentation	Option <sup>1)</sup>
ATEX	Ex ia IIC	II 1/2 G	FMB50, FMB51, FMB52	- 4 to 20 mA HART	- XA00474P/00	BA
	Ex t IIC	II 1/2 D	FMB50, FMB51	- 4 to 20 mA HART	- XA00475P/00	BB
	Ex nA	II 3 G	FMB50, FMB51, FMB52, FMB53	- 4 to 20 mA HART - PROFIBUS PA - FOUNDATION Fieldbus	- XA00477P/00	BD
	Ex ia IIC	II 2 G	FMB50, FMB51, FMB52, FMB53	- 4 to 20 mA HART	- XA00474P/00	BE
	Ex ic IIC	II 3 G	FMB50, FMB51, FMB52, FMB53	- 4 to 20 mA HART	- XA00494P/00	BG
	Ex ia IIC Ex ia IIC	II 1/2 G II 1/2 D	FMB50, FMB51	- 4 to 20 mA HART	- XA00476P/00	B1

1) Product Configurator, "Approval" ordering feature

Directive	Approval	EPL	Type	Electronics	Documentation	Option <sup>1)</sup>
IECEx	Ex ia IIC	Ga/Gb	FMB50, FMB51, FMB52	- 4 to 20 mA HART	- XA00478P/00	IA
	Ex ia IIC	Gb	FMB52, FMB53	- 4 to 20 mA HART	- XA00478P/00	IC
	Ex t IIC	Da/Db	FMB50, FMB51	- 4 to 20 mA HART	- XA00479P/00	ID
	Ex ic IIC	Gc	FMB50, FMB51, FMB52, FMB53	- 4 to 20 mA HART	- XA00493P/00	IE
	Ex ia IIC Ex ia IIC	Ga/Gb Da/Db	FMB50, FMB51	- 4 to 20 mA HART	- XA00480P/00	I1

1) Product Configurator, "Approval" ordering feature

Directive	Approval	Type	Electronics	Documentation	Option <sup>1)</sup>
NEPSI	Ex ia IIC	FMB50, FMB51, FMB52, FMB53	- 4 to 20 mA HART - PROFIBUS PA - FOUNDATION Fieldbus	- XA00535P/00	NA

1) Product Configurator, "Approval" ordering feature

Directive	Approval	Electronics	Documentation	Option <sup>1)</sup>
TIIS	Ex ia IIC T4	- 4 to 20 mA HART	-	TA

1) Product Configurator, "Approval" ordering feature

Directive	Approval	Type	Electronics	Documentation	Option <sup>1)</sup>
INMETRO	Ex ia IIC T6...T4 Ga/Gb Ex ia IIC T6...T4 Gb	FMB50, FMB51, FMB52	- 4 to 20 mA HART - PROFIBUS PA - FOUNDATION Fieldbus	- XA01304P/00	MA

1) Product Configurator, "Approval" ordering feature

### Installation/Control Drawings

Directive	Approval	Type	Electronics	Documentation	Option <sup>1)</sup>
FM	FM IS Cl.I,II,III Div.1 Gr.A-G, AEx ia, FM NI Cl.I Div.2 Gr.A-D, FM IS: Zone 0, 1, 2, 20, 21, 22/ FM NI: Zone 2	FMB50	- 4 to 20 mA HART - PROFIBUS PA, FOUNDATION Fieldbus	- ZD00236P/00 - XA00566P/00	FA
	FM IS Cl.I,II,III Div.1 Gr.A-G, AEx ia, Zone 0,1, 2, 20, 21, 22	FMB51	- 4 to 20 mA HART - PROFIBUS PA, FOUNDATION Fieldbus	- - XA00566P/00	
	FM DIP Cl.II,III Div.1 Gr.E-G, Zone 21, 22	FMB50, FMB51	- 4 to 20 mA HART - PROFIBUS PA - FOUNDATION Fieldbus	-	FC
	FM NI Cl.I Div.2 Gr.A-D, Zone 2	FMB50, FMB51	- 4 to 20 mA HART - PROFIBUS PA - FOUNDATION Fieldbus	-	FD
	FM IS Cl.I Div.1 Gr.A-D, AEx ia, Zone 0, 1, 2	FMB52, FMB53	- 4 to 20 mA HART - PROFIBUS PA, FOUNDATION Fieldbus	- ZD00236P/00 - XA00566P/00	FE
CSA	C/US IS Cl.I,II,III Div.1 Gr.A-G, C/US IS Cl.I Div.2 Gr.A-D, Ex ia, Zone 0,1, 2	FMB50, FMB53	- 4 to 20 mA HART - PROFIBUS PA, FOUNDATION Fieldbus	- ZD00239P/00 - XA00560P/00	CA
	C/US IS Cl.I,II,III Div.1 Gr.A-G, C/US IS Cl.I Div.2 Gr.A-D, Ex ia C: Zone 0, 1, 2/ US: Zone 0, 1, 2, 20, 21, 22	FMB51, FMB52	- 4 to 20 mA HART - PROFIBUS PA, FOUNDATION Fieldbus	- - XA00560P/00	
	CSA C/US Cl.II, III Div.1 Gr.E-G	FMB50	- 4 to 20 mA HART	-	CC
	CSA C/US Cl.II, III Div.1 Gr.E-G US: Zone 21, 22	FMB51	- 4 to 20 mA HART	-	

1) Product Configurator, "Approval" ordering feature

### Combination certificate

Directive	Approval	Electronics	Documentation	Option <sup>1)</sup>
KEMA/ FM / CSA	ATEX II Ex ia + FM/CSA IS ATEX II 1/2G Ex ia IIC T6 + FM/CSA IS Cl.I Div.1 Gr.A-D, FM/CSA: Zone 0,1,2	- 4 to 20 mA HART	- ZD00236P/00 - ZD00239P/00	8C
		PROFIBUS PA, FOUNDATION Fieldbus	- XA00474P/00	

1) Product Configurator, "Approval" ordering feature

### Overfill protection

WHG (FMB50, FMB51, FMB52): ZE00275P/00/DE

## Registered trademarks

---

<b>HART®</b>	Registered trademark of the HART Communication Foundation, Austin, USA
<b>PROFIBUS®</b>	Registered trademark of the PROFIBUS User Organization, Karlsruhe, Germany
<b>FOUNDATION™ Fieldbus</b>	Registered trademark of the Fieldbus Foundation, Austin, Texas, USA





[www.addresses.endress.com](http://www.addresses.endress.com)

---