

Technical Information

Liquistation CSF48

Automatic stationary sampler for liquid media
Integrated controller with up to four measuring channels
and optional digital Memosens technology



Application

Liquistation CSF48 is a stationary sampler designed for the fully automated removal, defined distribution, and temperature-controlled storage of liquid media. The standard product version has two 0/4 to 20 mA analog inputs, two binary inputs and two binary outputs. Thanks to the modular platform concept, the CSF48 can be quickly and easily modified to create a measuring station.

- Municipal and industrial sewage treatment plants
- Laboratories and Water Conservancy Boards
- Monitoring of liquid media in industrial processes

Your benefits

- Four different kinds of housing material
- Two-door housing for reliable sample temperature regulation
- Air circulation in both the upper and lower enclosure
- Swift menu guidance, navigator and large display
- Dual bottle trays for easy sample transportation
- Practice-oriented programs ranging from simple time programs to event programs
- Functionality can be extended by installing modular electronic components
- Integrated data logger for recording measured values
- Service interface for data transmission
- Optional battery backup system ensures uninterrupted operation in the event of power failure

Contents

Function and system design	4	Protocol-specific data	24
Liquistation CSF48 sampler	4	HART	24
Liquistation CSF48 sampler with Samplefit CSA420 sampling assembly	5	PROFIBUS-DP	24
Sampler with online measurement	6	Modbus RS485	25
Mode of operation with a vacuum pump	7	Modbus TCP	25
Mode of operation with a peristaltic pump	9	Web server	25
Mode of operation with a sampling assembly	10	Power supply	25
Sampling with a flow assembly	11	Electrical connection	25
Sample distribution	12	Supply voltage	25
Sample preservation	12	Cable entry	26
Sampling control	15	Mains fuse	26
Intake speed with different suction lines	15	Power consumption	26
Sample temperature regulation (optional)	16	Power failure	26
Sampler housing	16	Performance characteristics	26
Equipment architecture	17	Sampling methods	26
Slot and port assignment	17	Dosing volume	26
Communication and data processing	18	Dosing accuracy	26
Dependability	18	Repeatability	26
Reliability	18	Intake speed (vacuum pump / peristaltic pump)	27
Maintainability	19	Suction height	27
Safety	21	Hose length	27
Input	21	Temperature control (optional)	27
Input types	21	Installation	27
Measured variables	21	Installation instructions	27
Temperature inputs	21	Mounting conditions for Liquistation CSF48	28
Measuring range	21	Installation conditions for Samplefit CSA420 sampling assembly	29
Input type	21	Environment	30
Accuracy	21	Ambient temperature range	30
Binary input, passive	21	Storage temperature	30
Span	21	Degree of protection	30
Signal characteristics	21	Electromagnetic compatibility	30
Analog input, passive/active	21	Electrical safety	30
Span	21	Relative humidity	30
Accuracy	21	Process	30
Output	22	Medium temperature range	30
Output signal	22	Medium properties	30
Signal on alarm	23	Process pressure	30
Load	23	Process connection	30
Linearization/transmission behavior	23	Process connection Samplefit CSA420 sampling assembly ..	31
Current outputs, active (optional)	23	Mechanical construction	32
Relay outputs (optional)	23	Dimensions	32
Electrical specification of relay types	23	Weight	33
		Material	34

Operability	35
Operating concept	35
Display	35
Local operation	35
Remote operation	36
Communication	37
Software	37
Ordering information	38
Product structure	38
Scope of delivery	38
Certificates and approvals	38
CE mark	38
MCERTS	38
cCSAus	38
Accessories	39
Accessories for Liquistation CSF48	39
Sensors	40
Measuring cable	43

Function and system design

Liquistation CSF48 sampler

A complete sampling unit comprises:

Liquistation CSF48 for open channels include the following, depending on version:

- Controller with display, soft keys and navigator
- Vacuum or peristaltic pump for sampling
- PE or glass sample bottles for sample preservation
- Sampling chamber temperature regulator (optional) for safe sample storage
- Suction line with suction head

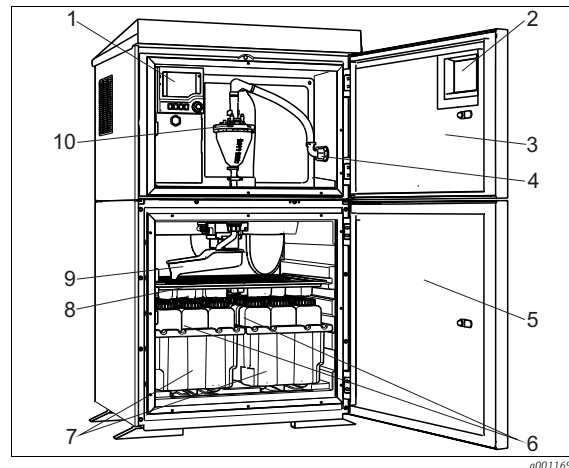

Example of a Liquistation CSF48, version with vacuum pump

- 1 Controller
- 2 Window (optional)
- 3 Dosing chamber door
- 4 Suction line connection
- 5 Sampling chamber door
- 6 Sample bottles, e.g. 2 x 12 PE 1 liter bottles
- 7 Bottle trays (depending on sample bottles selected)
- 8 Distribution plate (depending on sample bottles selected)
- 9 Distribution arm
- 10 Vacuum system, e.g. dosing system with conductive sample sensor

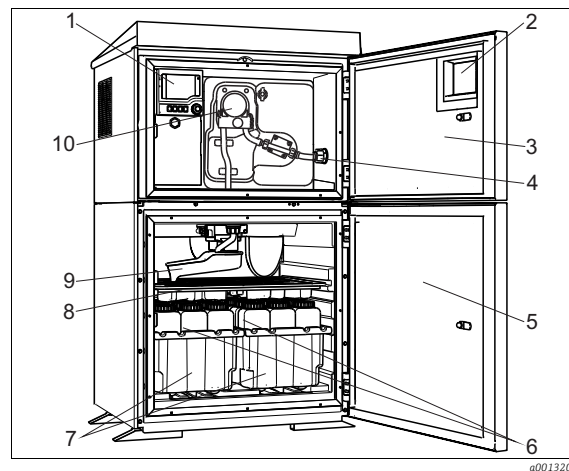

Example of a Liquistation CSF48, version with peristaltic pump

- 1 Controller
- 2 Window (optional)
- 3 Dosing chamber door
- 4 Suction line connection
- 5 Sampling chamber door
- 6 Sample bottles, e.g. 2 x 12 PE 1 liter bottles
- 7 Bottle trays (depending on sample bottles selected)
- 8 Distribution plate (depending on sample bottles selected)
- 9 Distribution arm
- 10 Peristaltic pump

Liquistation CSF48 sampler with Samplefit CSA420 sampling assembly

A complete sampling unit for pressurized pipes comprises:

Liquistation CSF48 and Samplefit CSA420 sampling assembly with:

- Controller with display, soft keys and navigator
- Samplefit CSA420 sampling assembly for 10 ml, 30 ml or 50 ml sample volume, depending on version
- PE or glass sample bottles for sample preservation
- Sampling chamber temperature regulator (optional) for safe sample storage

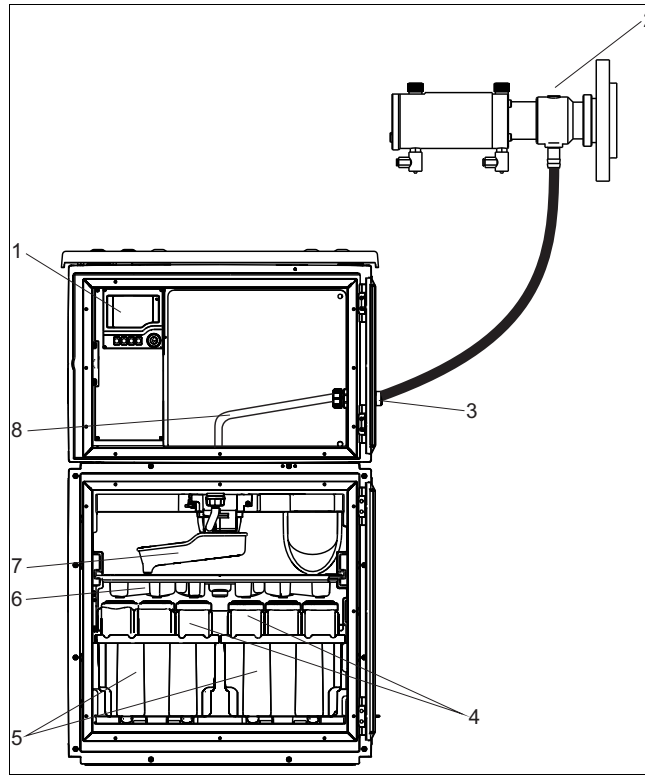

- 1 Controller
- 2 Samplefit CSA420 sampling assembly
- 3 Gland for suction line
- 4 Sample bottles, e.g. 2 x 12 PE 1 liter bottles
- 5 Bottle trays (depending on sample bottles selected)
- 6 Distribution plate (depending on sample bottles selected)
- 7 Distribution arm
- 8 Gland for suction line

Example of a Liquistation CSF48 with CSA420 sampling assembly

Example of Samplefit CSA420 sampling assembly with flange connection

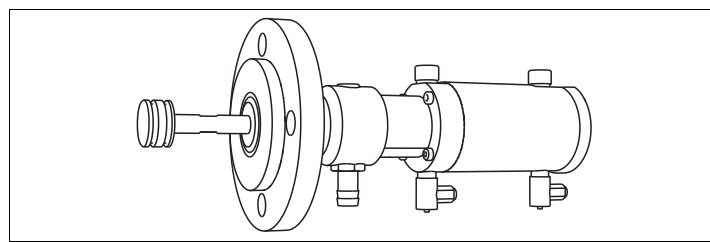

Samplefit CSA420 sampling assembly with flange connection DN50, PP

Example of Samplefit CSA420 sampling assembly with triclamp connection

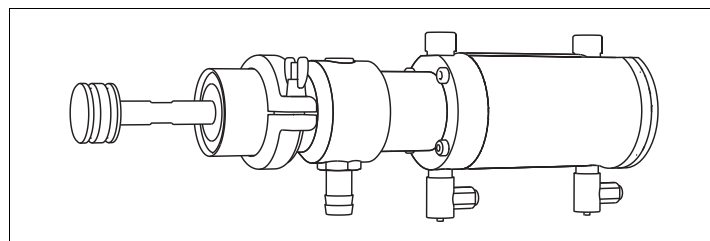

Samplefit CSA420 sampling assembly with triclamp connection DN50, DIN 32676

Sampler with online measurement

i The following overview shows examples of the design and layout of a measuring system. Other sensors and assemblies can be ordered for conditions specific to your application. See Accessories section and also --> www.endress.com/products

Measuring point

A complete measuring system with online measurement consists of:

- Liquistation CSF48 sampler
- Sensors with Memosens technology
- Immersion or flow assemblies to suit the sensors used

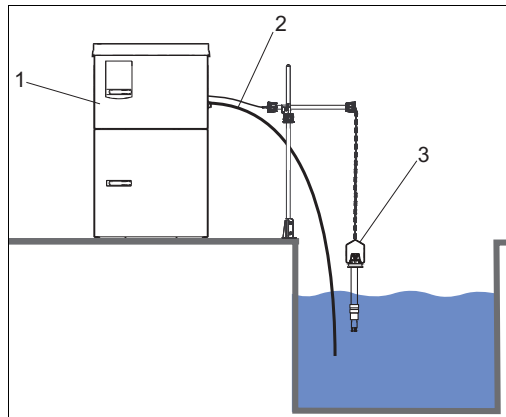

a0013214

Measuring system

- 1 Liquistation CSF48
- 2 Suction line
- 3 Sensors with immersion assembly

Nitrate

- Viomax CAS51D sensor with fixed cable
- Flexdip CYA112 assembly
- Flexdip CYH112 holder

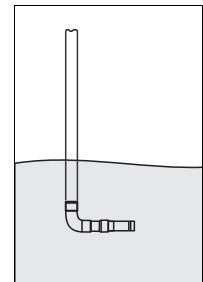

a0013297

Conductivity

Inductive conductivity measurement

- Flexdip CYA112 immersion assembly
- Indumax CLS50D sensor with fixed cable

Conductive conductivity measurement

- Flexdip CYA112 immersion assembly
- Condumax CLS15D sensor

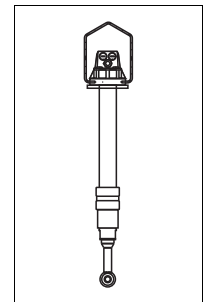

a0013346

Oxygen

- Flexdip CYA112 immersion assembly
- Flexdip CYH112 holder
- Sensor
 - Oxymax COS61D (optical) with fixed cable,
 - Oxymax COS51D (amperometric) cable CYK10

Figure: CYA112 with COS61D

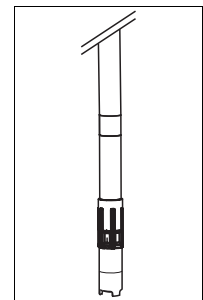

a0012415

pH value or ORP

- Retractable assembly Cleanfit CPA471
- Orbisint CPS11D, CPS12D sensor
- Measuring cable CYK10

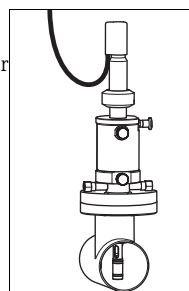

a0012413

Turbidity

- Flexdip CYA112 immersion assembly
- Spray head CUR4 (optional)
- Turbimax CUS51D sensor with fixed cable

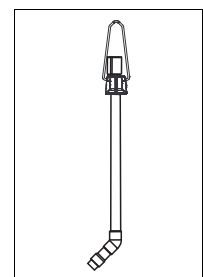

a0013294

- Flexdip CYA112 immersion assembly
- Orbisint CPS12D, CPS11D sensor
- Measuring cable CYK10

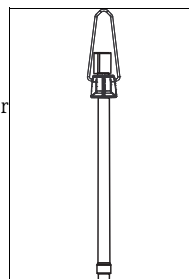

a0012787

- Flowfit CUA250 flow assembly
- Turbimax CUS51D sensor with fixed cable

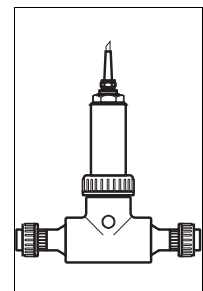

a0012788

Mode of operation with a vacuum pump

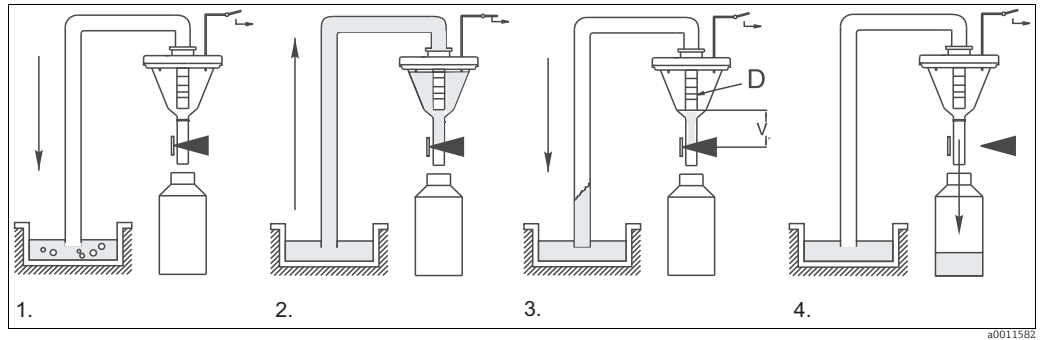

Sampling with a vacuum pump

Sampling takes place in four steps:

1. **Blow clear**
The hose valve is closed. The vacuum pump blows the suction line clear via the dosing system.
2. **Intake**
The "air manager" - a pneumatic control unit - switches the air path of the vacuum pump to "intake". The sample is drawn into the dosing beaker under vacuum. The level of liquid reaches the detectors of the dosing system.
3. **Dose**
The intake process is completed and pressure compensation takes place. Depending on the position of the dosing tube (D), the excess sample liquid flows back to the sampling point.
4. **Drain**
The hose clamp is opened and the sample is drained into the sample bottle.

Dosing system with conductive sample sensor

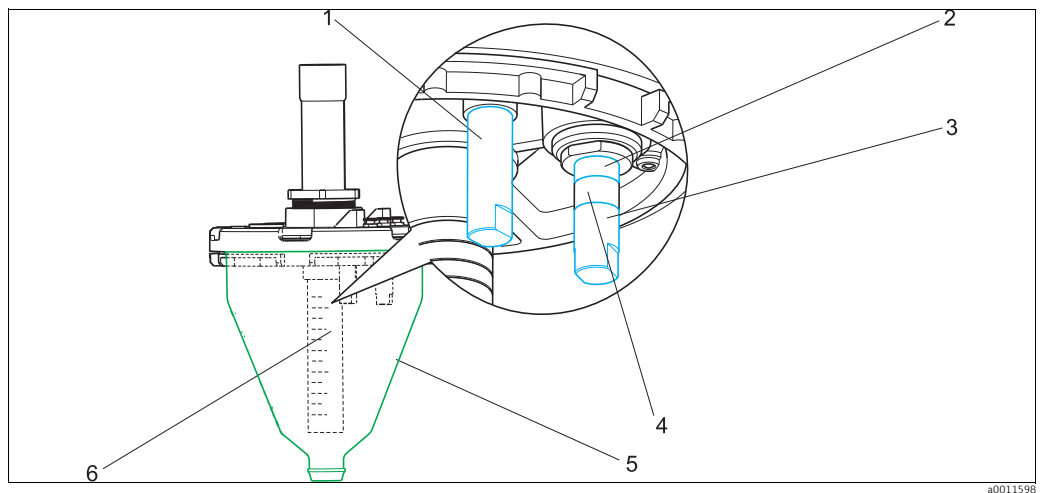

Conductive dosing system

- 1 Conductivity sensor 1 (common electrode)
- 2 Conductivity sensor 2 (safety electrode)
- 3 Conductivity sensor 3 (standard electrode)
- 4 Insulation
- 5 Dosing beaker (plastic version with graduated scale or glass)
- 6 Graduated dosing tube, white and blue scale

Not shown since hidden: hose connection for vacuum pump --> graphic for "Capacitance dosing system"

Level detection principle

When the sample is drawn in, the sample level reaches conductivity sensors 1 and 3. The system thus detects that the dosing beaker is filled and terminates the suction process.

If sensor 3 is heavily fouled or fails, conductivity sensor 2 switches to safety mode and turns off the system. This patented sample detection method along with predictive maintenance information prevent vacuum pump failure as a result of flooding.

Dosing system with capacitance sample sensor

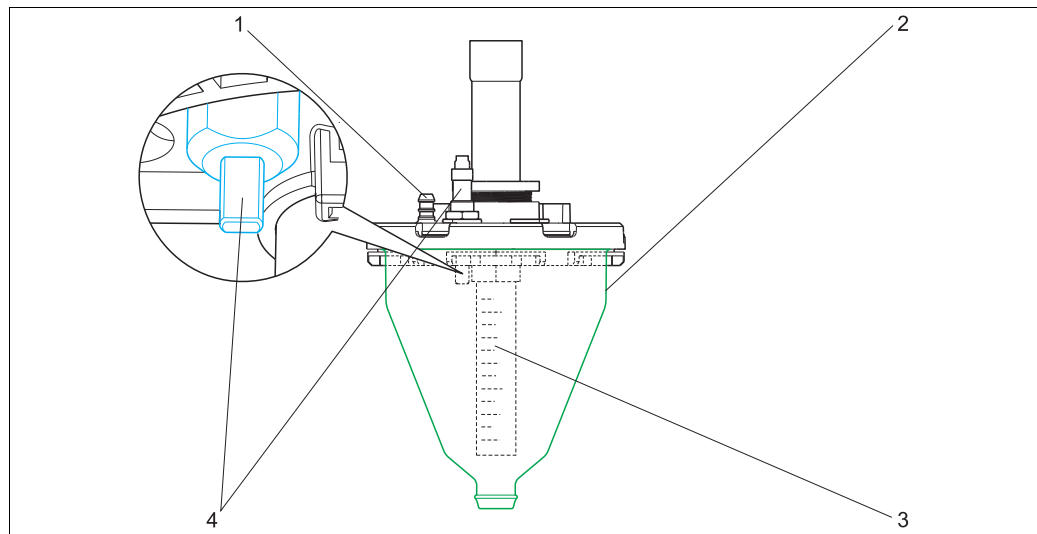

Capacitance dosing system

- 1 Hose connection for the vacuum pump
- 2 Graduated dosing beaker
- 3 Graduated dosing tube, white and blue scale
- 4 Capacitance level sensor

Level detection principle

When the level of medium in the dosing beaker changes, the capacitance of a capacitor partly formed by the liquid also changes.

The capacitance sensor ensures rapid sample detection in foaming media and media with a high fat content as well as in media with a conductivity $< 30 \mu\text{S}/\text{cm}$. In the case of the latter, only capacitance level detection is possible.

i Sample dosing with/without pressure

Sample dosing without pressure is the factory setting for all standard applications in which the sample medium is taken from an open channel or a gravity line. The excess sample can flow back under atmospheric pressure.

Sample dosing with pressure is selected for applications in which the sample is taken from a pipe, or for applications involving a low suction height and a low sample volume. In such instances, the sample medium cannot flow back on its own. The maximum pressure in the pipe must be $< 0.8 \text{ bar}$. Pressure is applied and the excess sample is forced out of the dosing beaker and back to the sampling point.

The sampling volume is set by adjusting the dosing tube. The white "A" scale applies if dosing without pressure, and the blue "B" scale applies if dosing with pressure.

Mode of operation with a peristaltic pump

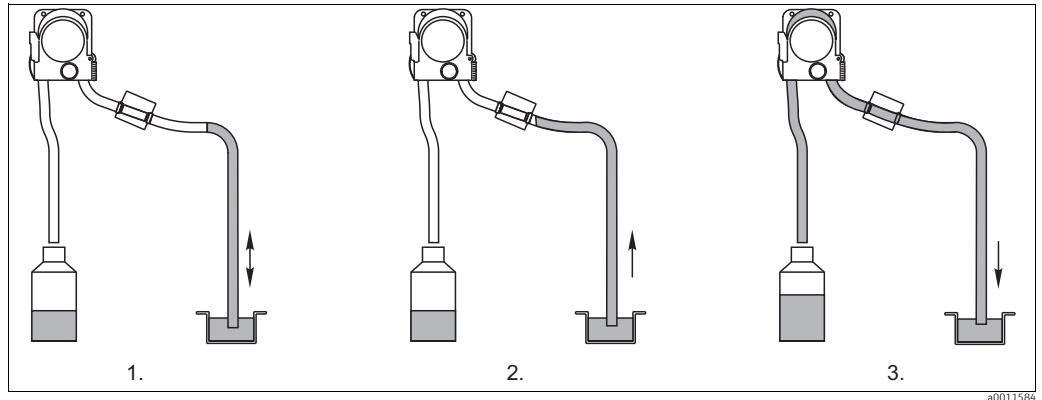

Sampling steps with a peristaltic pump

Sampling takes place in three steps:

1. **Rinse**
The peristaltic pump runs in reverse and forces medium back to the sampling point.
2. **Intake**
The peristaltic pump runs forward and draws in medium. If the medium detection system detects the sample, the pump is controlled by the flow and the specified sample volume is calculated automatically.
3. **Drain**
The pump runs in reverse again and forces the medium back to the sampling point.

One advantage this system offers for obtaining a representative sample is the possibility of rinsing the suction line several times:

Medium is initially drawn in until the medium detection system reacts, then the pump switches and forces the medium back to the sampling point. This process can be repeated a maximum of three times. The sample is then taken as described.

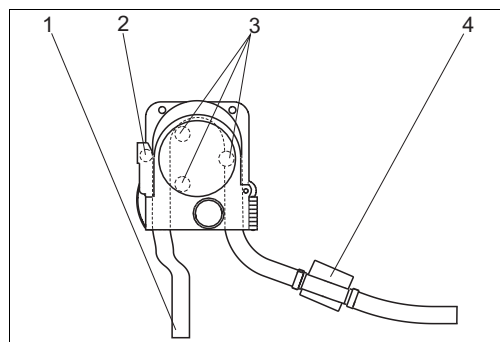

- 1 Pump tubing
- 2 Safety switch (optional)
- 3 Pump rollers
- 4 Medium detection system (patented)

Peristaltic pump

The pump rollers deform the hose, thereby causing a negative pressure and the suction effect. The medium detection system is based on a pressure sensor which detects the difference between a pipe that is filled and not filled.

Thanks to a patented process for automatically detecting the suction height, the user does not have to enter the suction height or suction line length. The self-learning software guarantees that the sample volume remains constant.

An optional safety switch integrated in the pump housing immediately switches off the pump when the pump is opened (recommended if third-party staff are performing maintenance work).

Mode of operation with a sampling assembly

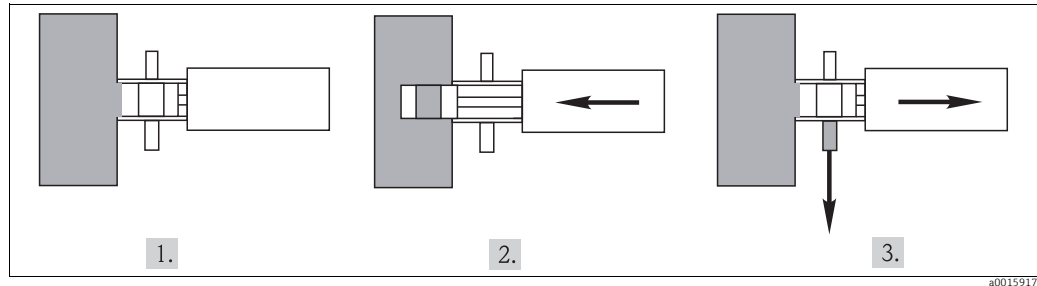

Sampling steps with a sampling assembly

Sampling takes place in three steps:

1. **Standby position**
The plunger is in standby position in the assembly. The sample chamber is ventilated from the outside.
2. **Intake**
The plunger is driven by compressed air into the sample flow. An adjustable hold time allows for a representative blending of the sample in the sample chamber.
3. **Drain**
The plunger is in standby position in the assembly. The sample chamber is ventilated from the outside. The sample is drained into the sample bottle(s).

Sampling assembly with optional rinsing valve

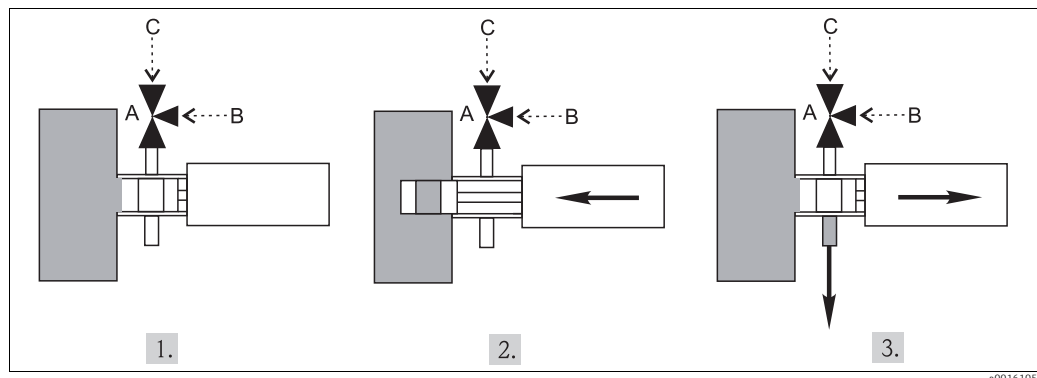

Sampling steps with a sampling assembly

- A Rinsing valve
B Compressed air
C Atmosphere

The rinsing valve provides you with these additional functions:

- Draining under pressure - valve is connected to compressed air
 - In the sampling setup menu, the function "Dosing under pressure" can be selected. This allows the sample to flow under pressure into the sample bottle(s).
- Cleaning with compressed air or water
 - In the sampling setup menu, the function "Cleaning" with air or water can be selected. Once you select "before", "after" or "before and after every sampling", you can choose a cleaning position.
- In addition, you can select sample rinsing cycles in the "Cleaning before and after sampling" menu. The system can be pre-rinsed up to 10 times with the current sample.

i Automatic sampling using the sampling assembly is designed for aqueous samples. For highly viscous samples, e.g. sludge >1 %, sampling can only be done directly into a container.

The air or water pressure must be set for the application in question using pressure reducing valves.

Sampling with a flow assembly

A flow assembly is integrated in the stand for sampling purposes.

The flow assembly is used when sampling in pressurized systems, e.g.:

- Containers located at a higher level
- Pressurized pipes
- Pumping with external pumps

The flow rate should be 1000 to 1500 l/h.

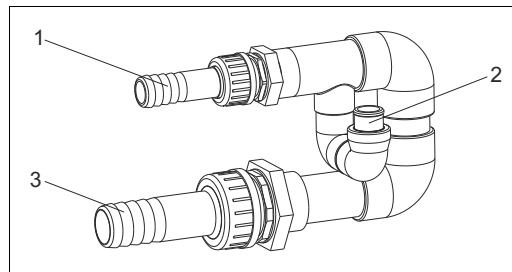

- 1 Flow assembly inlet: 3/4"
- 2 Sample connection
- 3 Flow assembly outlet: 1 1/4"

a0013127

Flow assembly

(can also be ordered separately as kit no.: 71119408)

- i** The outlet of the flow assembly must be unpressurized (e.g. drain, open channel)!

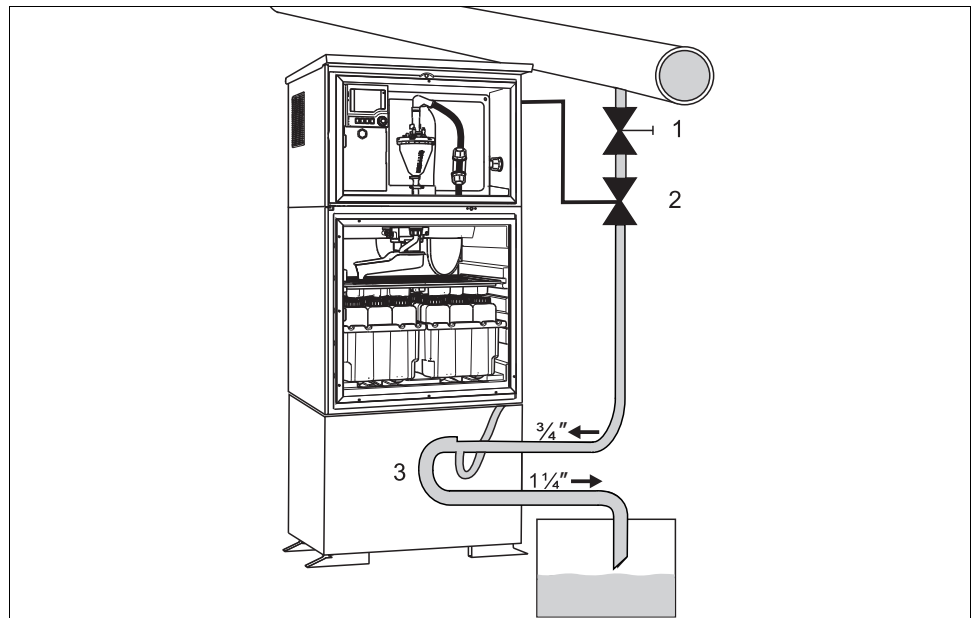

a0013458

Example: Sampling from pressure piping

- 1 Ball valve 1
- 2 Valve 2
- 3 Flow assembly integrated into the stand

Use the ball valve 1 to set the flow rate to 1000 l/h to 1500 l/h. When the sampling cycle begins, you can use one of the relay outputs to control and open valve 2. The medium flows through the pipe and the flow assembly into the outflow. When an adjustable delay time has elapsed, the sample is taken directly from the flow assembly. Valve 2 is closed again once the sample has been taken.

- i** Valve 1 and 2 are not included in the scope of delivery (order code: 71180379).

Sample distribution

CSF48 offers a wide range of bottle combinations and distribution versions. The versions can be changed or replaced easily without the need for special tools. In addition, the software program makes it possible to configure individual bottles and bottle groups and assign them to switchover or event programs.

Sample preservation

The sample bottles are located in the sample compartment. This is fitted with a seamless plastic dish to ensure easy cleaning.

All parts that transport medium (distribution arm, dosing system, distribution plate...) can be removed and cleaned easily without the need for tools.

















a0015209

Distribution plate, bottle trays and rotary arm

- i** Distribution version "V":
The maximum sample volume per sample is limited to 80 ml of liquid containing small amounts of solids. A special distribution arm and distribution plate are used
- i** Distribution version "W":
This version contains one locating insert for 4 x 5000 ml Schott Duran GLS 80 glass bottles. These glass bottles must be ordered from your local Schott dealer.

Bottle groups and distribution version depending on the order version:

	CSF48-*****																					
	B	C	D	E	G	H	J	K	L	M	N	O	P	Q	R	S	T	U	V	W		
30 liter, PE, direct distribution 	1																					
60 liter, PE, direct distribution 		1																				
25 liter, PE, direct distribution 			2											1	1							
17 liter, PE, direct distribution 																	4					
13 liter, PE, direct distribution 				4																		
5 liter, glass, preparation 																					4	
3.8 liter, glass, direct distribution 																		4				
3 liter, PE, plate distribution 					12			6	6					6								
2 liter, PE, plate distribution 																					24	

	CSF48-*****																				
	B	C	D	E	G	H	J	K	L	M	N	O	P	Q	R	S	T	U	V	W	
1 liter, PE, plate distribution 						24			12	12					12						
1 liter, glass, plate distribution 							24														
13 liter, PE, plate distribution 								2	2												
2 liter, PE, direct distribution 												12		6							
1 liter, PE, direct distribution 													24	12							
1.8 liter, glass, plate distribution 																	12				

Sampling control

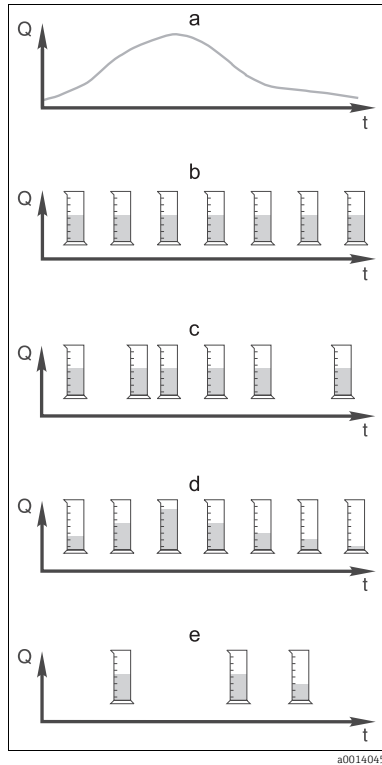

- a. Flow curve
- b. **Time-proportional sampling**
A constant sample volume (e.g. 50 ml) is taken at regular intervals (e.g. every 5 min).
- c. **Volume-proportional sampling**
A constant sample volume is taken at variable intervals (depending on the inflow volume).
- d. **Flow-proportional sampling**
A variable sample volume (the sample volume depends on the inflow) is taken at regular intervals (e.g. every 10 min).
 Only in version with peristaltic pump.
- e. **Event-controlled sampling**
Sampling is triggered by an event (e.g. pH limit value).
Sampling can be time-paced, volume-paced or flow-paced, or single samples can be taken.

Single and multiple samples can also be grouped in a program in addition to the sampling methods listed. Furthermore, the software allows interval sampling, switchover and event functions. The latter permit up to 24 subprograms to be active simultaneously for a variety of applications. A sampling table makes it possible for users to program the bottle assignment, time interval and sample volume. Signals for external control can be connected via 2 analog inputs and 2 binary inputs in the standard version of the product. Customized text is entered to ensure the correct assignment of the inputs in the memory.

Intake speed with different suction lines

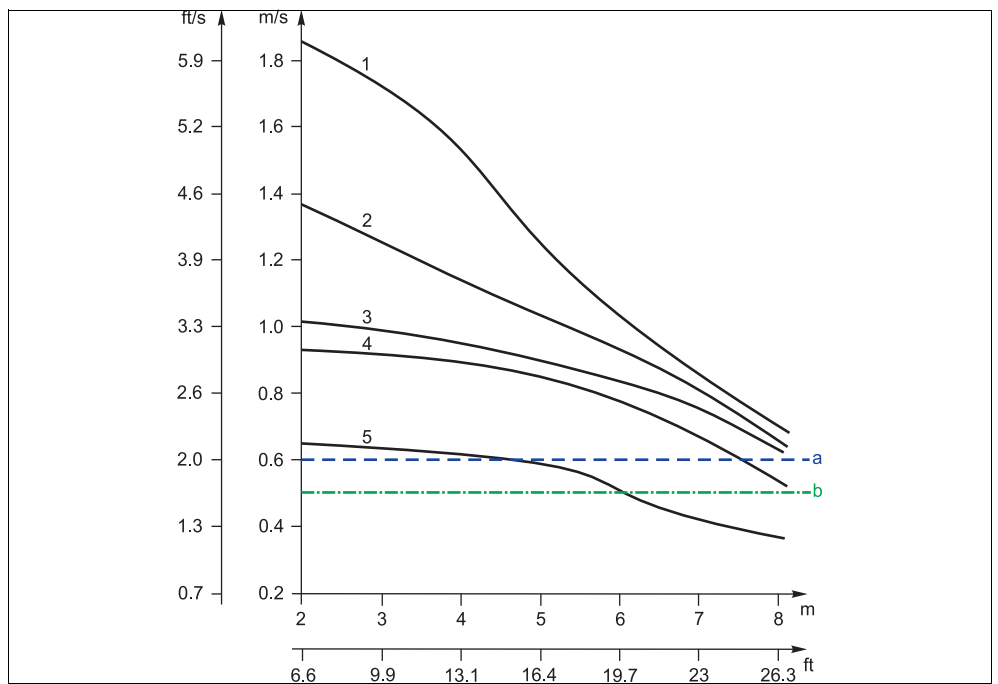

Intake speed in m/s with suction height in m

- a Intake speed as per Ö 5893 (Austrian standard); US EPA
- b Intake speed as per EN 25667, ISO 5667
- 1 ID 10 mm (3/8") vacuum pump
- 2 ID 13 mm (1/2") vacuum pump
- 3 ID 10 mm (3/8") peristaltic pump
- 4 ID 16 mm (5/8") vacuum pump
- 5 ID 19 mm (3/4") vacuum pump

Sample temperature regulation (optional)

The temperature of the sample compartment can be adjusted using the controller. The factory setting is 4 °C (39 °F). The current temperature is shown on the display and recorded in the internal data logger. A temperature sensor for measuring individual sample temperatures can also be ordered as an option.

The vaporizer and defrost heater are integrated in a special housing such that they are protected against corrosion and damage. The compressor and condenser are located in the upper section of the sampler. They can be easily accessed by removing the upper rear panel (for maintenance purposes).



Cooling system

Sampler housing

Please note the mounting conditions in the "Installation" section and the information on materials for the different housing types in the "Mechanical construction" section.

- i** Plastic polystyrene VO can change color when exposed to direct sunlight. In the case of a stainless steel housing, the frame around the window can change color when exposed to direct sunlight. For outdoor use without a weather protection cover, the use of Plastic ASA+PC VO is recommended. The functionality is not affected by the discoloration.

Equipment architecture

Slot and port assignment

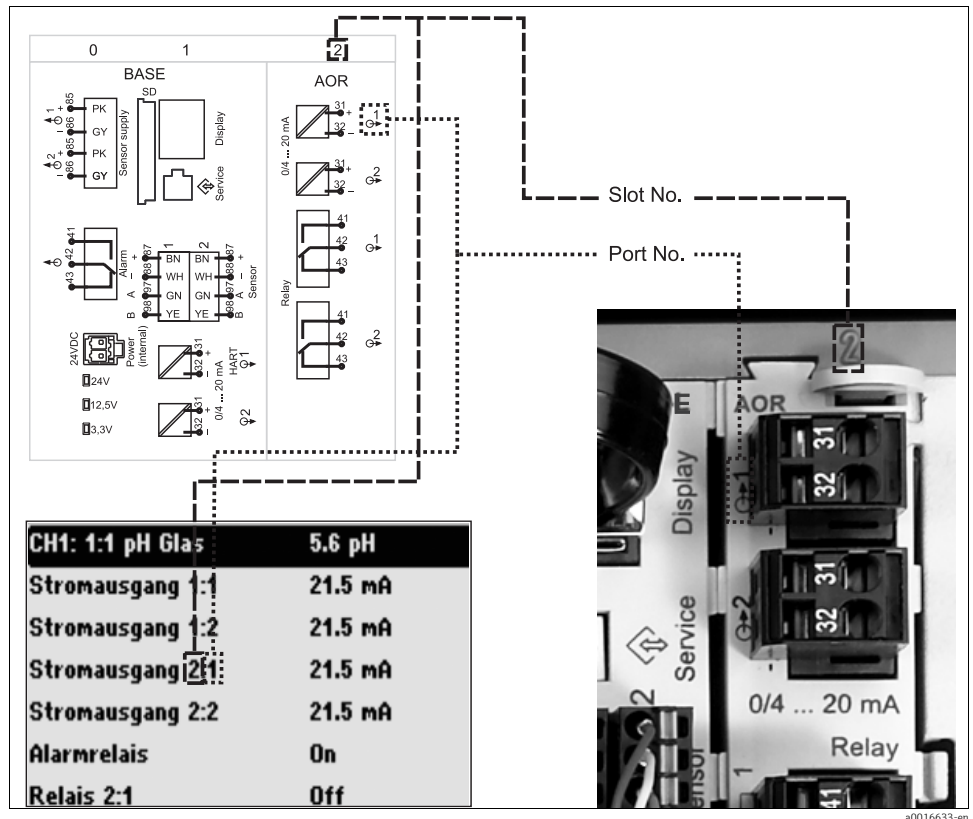

Slot and port assignment of hardware and how this information appears on the display

The electronic components are modular in design:

- There are several points available to connect electronic modules. These are known as "slots".
- The slots are numbered consecutively in the housing. Slots 0 and 1 are always reserved for the basic module.
- Each electronic module has one or more inputs and outputs or relays, collectively termed "ports" here.
- The ports are numbered consecutively for each electronic module and are automatically detected by the software.
- Outputs and relays are named according to their function, e.g. "current output", and are displayed with the slot and port numbers in ascending order.

Example:

– "Current output 2:1" means:

Slot 2 (e.g. AOR module) : Port 1 (current output 1 of AOR module)

- Inputs are assigned to measuring channels in ascending order, "Slot:Port number"

Example:

– "CH1: 1:1" means:

Slot 1 (basic module) : Port 1 (input 1) is channel 1 (CH1) and a conductivity sensor is connected to it



The unique terminal name is composed as follows:

Slot no. : Port no. : Terminal

Communication and data processing

Communication types:

- Fieldbuses
 - HART
 - PROFIBUS DP (Profile 3.02)
 - Modbus TCP or RS485
- Configuration via Ethernet
- EtherNet/IP

i Only one type of fieldbus communication can ever be active. The last activation code entered determines which bus is used.

Bus termination on the device

- Via slide switch at bus module 485
- Displayed via LED "T" on bus module 485

Dependability

Reliability

Memosens technology



Memosens makes your measuring point safer and more reliable:

- Non-contact, digital signal transmission enables optimum galvanic isolation
- No contact corrosion
- Completely watertight
- Laboratory sensor calibration possible, thus increasing measured value availability
- Predictive maintenance thanks to recording of sensor data, e.g.:
 - Total hours of operation
 - Hours of operation with very high or very low measured values
 - Hours of operation with high temperatures
 - Number of steam sterilizations
 - Sensor condition



a0013430

Sensor Check System (SCS)

The Sensor Check System (SCS) monitors the high impedance of the pH glass.

An alarm is triggered if a minimum impedance is not reached or if a maximum impedance is exceeded.

- The main cause of decreasing high-impedance is glass breakage.
- Causes of increasing impedance are:
 - dry sensor
 - worn out pH glass membrane.

Process Check System (PCS)

The PCS (Process Check System) tests the measuring signal for stagnation. If the measuring signal does not change over a certain period of time (several measured values), an alarm is triggered.

Main causes of stagnating measured values:

- Sensor is dirty or outside of medium
- Sensor is defective
- Process error (e.g. through control system)

Sensor Condition Check (SCC)

This function monitors the electrode status or the degree of wear and tear on the electrode. The status is conveyed via the messages "SCC electrode status bad" or "SCC electrode status satisfactory". The electrode status is updated following each calibration.

Maintainability

Modular design

The modular sampler design means it can be easily adapted to suit your needs:

- Retrofit add-on modules for new or extended range of functions, e.g. current outputs and relays
- Upgrade from one channel to multichannel measurement with digital sensors
- Upgrade to fieldbus communication (PROFIBUS DP, Modbus TCP, Modbus RS485, Ethernet for configuration and Ethernet/IP)



a0016793

E basic module for 2 sensors



a0016794

Communication module

Memory

- Independent, integrated ring memories (FIFO) or stack memories for recording
 - an analog value (e.g. flow, pH value, conductivity)
 - events (e.g. power failure)
 - sample statistics (e.g. sample volume, filling times, bottle assignment)
- Program memory: max. 100 programs
- Data logbooks
 - Adjustable scan time: 1 to 3600 s (6 h)
 - max. 8 data logbooks
 - 150,000 entries per logbook
 - Graphic display (load curves) or numeric listing
- Calibration logbook: max. 75 entries
- Hardware logbook:
 - Hardware configuration and modifications
 - max. 125 entries
- Version logbook:
 - e.g. software updates
 - max. 50 entries
- Operation logbook: max. 250 entries
- Diagnostic logbook: max. 250 entries

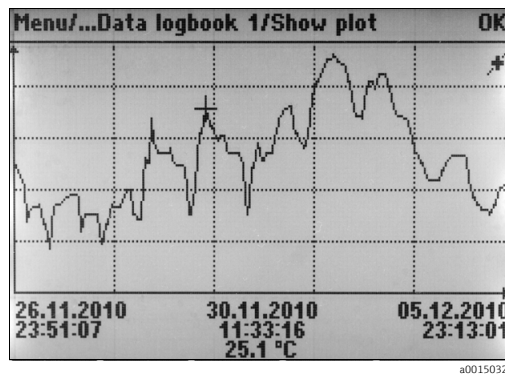

Data logbook: Graphic display

Mathematical functions (virtual process values)

In addition to "true" process values provided by connected physical sensors or analog inputs, you can have maximum 6 "virtual" process values calculated using mathematical functions.

The "virtual" process values can be:

- issued via a current output or fieldbus
- used as a control variable
- assigned as a measured variable to a limit contactor
- used as a measured variable to trigger cleaning
- displayed in user-defined measuring menus.

These mathematical functions are possible:

- pH calculation based on two conductivity values as per VGB 405 RL, e.g. in boiler feedwater
- Difference between two measured values from different sources, e.g. for membrane monitoring
- Differential conductivity, e.g. for monitoring the efficiency of ion exchangers
- Degassed conductivity, e.g. for process control systems in power plants
- Redundancy for monitoring two or three redundant measuring sensors
- rH calculation based on measured values of a pH sensor and an ORP sensor

FieldCare and Field Data Manager

Fieldcare

Software based on FDT/DTM technology for configuration and asset management

- Complete device configuration when connected via FXA291 and service interface
- Access to a number of configuration parameters and identification, measuring and diagnostic data when connected via HART modem
- Logbooks can be downloaded in CSV format or binary format for "Field Data Manager" software

Field Data Manager

Visualization software and database for measuring, calibration and configuration data

- SQL database which is protected against manipulation
- Functions to import, save and print out logbooks
- Load curves to display measured values

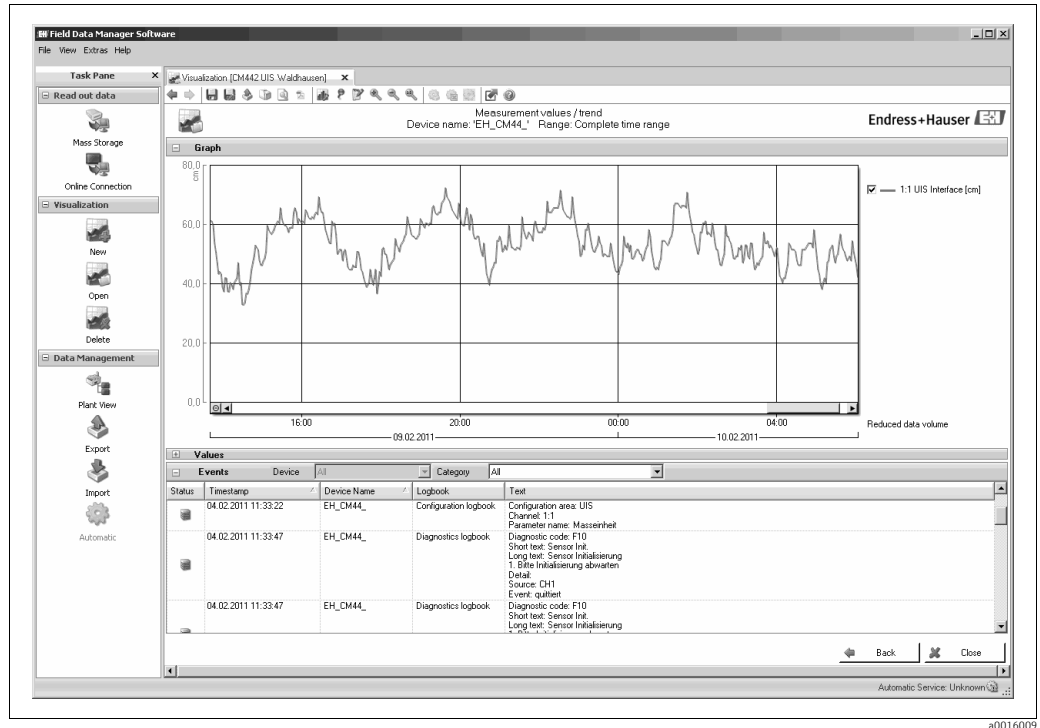

Field Data Manager: Load curves

SD card

The exchangeable storage medium enables:

- Quick and easy software updates and upgrades
- Data storage of internal device memory (e.g. logs)
- Transfer of complete configurations to a device with an identical setup (backup function)
- Transfer of configurations without the TAG and bus address to devices with an identical setup (copy function)

Endress+Hauser offers industry-approved SD cards as accessories. These memory cards provide maximum data security and integrity.

Other SD cards can also be used. However, Endress+Hauser does not accept any responsibility for the data security of such cards.

Safety

Real-time clock

The device contains a real-time clock. In the event of a power failure, a button cell battery is used. This ensures that if the device is restarted, the date and time settings are retained and the time stamp for the logbooks is correct.

Data security

All settings, logbooks etc. are stored in a non-volatile memory to ensure that the data are retained even if there is a disruption to the power supply.

Input

Input types

- 2 analog inputs
- 2 binary inputs + 2 binary inputs (optional)
- 1 to 4 digital inputs for sensors with Memosens protocol (optional)

Measured variables

--> Documentation of the connected sensor

Temperature inputs

Measuring range -30 to 70 °C (-20 to 160 °F)

Input type Pt1000

Accuracy ±0.5 K

Binary input, passive

Span 12 to 30 V, galvanically isolated

Signal characteristics Minimum pulse width: 100 ms

Analog input, passive/active

Span 0/4 to 20 mA,
galvanically isolated

Accuracy ±0.5 % of measuring range

Output

Output signal 2 binary outputs (standard) + 2 binary outputs (optional):
Open collector, max. 30 V, 200 mA

Depending on version (optional):

- 1 x 0/4 to 20 mA, active, HART communication, galvanically isolated from the sensor circuits and from one another
- 1 x 0/4 to 20 mA, active, galvanically isolated from the sensor circuits and from one another
- 2 x 0/4 to 20 mA, active, galvanically isolated from one another and from the sensor circuits
- 4 x 0/4 to 20 mA, active, galvanically isolated from the sensor circuits and from one another
- 6 x 0/4 to 20 mA, active, galvanically isolated from the sensor circuits and from one another

HART

Signal coding	FSK ± 0.5 mA above current signal
Data transmission rate	1200 baud
Galvanic isolation	Yes
Load (communication resistance)	250 Ω

PROFIBUS DP

Signal coding	EIA/TIA-485, PROFIBUS-DP-compliant acc. to IEC 61158
Data transmission rate	9.6 kBd, 19.2 kBd, 93.75 kBd, 187.5 kBd, 500 kBd, 1.5 MBd, 6 MBd, 12 MBd
Galvanic isolation	Yes
Connectors	Spring-cage terminal (max. 1.5 mm), bridged internally in the connector (T function), M12 optional
Bus termination	Internal slide switch with LED display

Modbus RS485

Signal coding	EIA/TIA-485
Data transmission rate	2400, 4800, 9600, 19200, 38400, 57600 and 115200 baud
Galvanic isolation	Yes
Connectors	Spring-cage terminal (max. 1.5 mm), bridged internally in the connector (T function), M12 optional
Bus termination	Internal slide switch with LED display

Ethernet and Modbus TCP

Signal coding	IEEE 802.3 (Ethernet)
Data transmission rate	10 / 100 MBd
Galvanic isolation	Yes
Connection	RJ45, M12 optional
IP address	DHCP or configuration using menu

EtherNET/IP

Signal coding	IEEE 802.3 (Ethernet)
Data transmission rate	10 / 100 MBd
Galvanic isolation	Yes
Connection	RJ45, optional M12 (D-encoded)
IP address	DHCP (default) or configuration via menu

Signal on alarm

Adjustable, as per NAMUR Recommendation NE 43

- In measuring range 0 to 20 mA (HART is not available with this measuring range):
Error current from 0 to 23 mA
- In measuring range 4 to 20 mA:
Error current from 2.4 to 23 mA
- Factory setting for error current for both measuring ranges:
21.5 mA

LoadMax. 500 Ω **Linearization/transmission behavior**

Linear

Current outputs, active (optional)

Span
0 to 23 mA

2.4 to 23 mA for HART communication

Signal characteristic

Linear

Electrical specification

Output voltage:

Max. 24 V

Cable specification

Recommended: shielded cable

Max. 2.5 mm² (14 AWG)

Relay outputs (optional)

Electrical specification of relay types

Relay types

- 2 x changeover contact, coupled with binary output (optional)
- 1 single-pin changeover contact (alarm relay)
- 2 or 4 relay cards (optional)

Relay switching capacity

Power unit (alarm relay)

Switching voltage	Load (max.)	Switching cycles (min.)
230 V AC, $\cos\phi = 0.8$ to 1	0.1 A	700,000
	0.5 A	450,000
24 V DC, L/R = 0 to 1 ms	0.1 A	500,000
	0.5 A	350,000

Relay coupled with binary output

Switching voltage	Load (max.)	Switching cycles (min.)
230 V AC, $\cos\phi = 0.8$ to 1	5 A	100,000
24 V DC, L/R = 0 to 1 ms	5 A	100,000

Extension module

Switching voltage	Load (max.)	Switching cycles (min.)
230 V AC, $\cos\phi = 0.8$ to 1	0.1 A	700,000
	2 A	120,000
115 V AC, $\cos\phi = 0.8$ to 1	0.1 A	1,000,000
	2 A	170,000
24 V DC, L/R = 0 to 1 ms	0.1 A	500,000
	2 A	150,000

Minimum load (typical)

- Min. 100 mA with 5 V DC

- Min. 1 mA with 24 V DC
- Min. 5 mA with 24 V AC
- Min. 1 mA with 230 V AC

Protocol-specific data

HART

Manufacturer ID	11 _h
Device type	119C _h (CM44x), 119D _h (CSFxx)
Device revision	001 _h
HART version	7.2
Device description files (DD/DTM)	www.endress.com Device Integration Manager (DIM)
Device variables	Dynamic variables PV, SV, TV, QV, 16 of which can be configured by the user and 16 of which are pre-defined
Supported features	PDM DD, AMS DD, DTM, FieldXpert DD

PROFIBUS-DP

Manufacturer ID	11 _h
Device type	155D _h (CM44x), 155C _h (CSFxx)
Profile version	3.02
GSD files	www.products.endress.com/profibus Device Integration Manager DIM
Output variables	16 AI blocks, 8 DI blocks
Input variables	8 AO blocks, 4 DO blocks
Supported features	<ul style="list-style-type: none"> ■ 1 MSCY0 connection (cyclical communication, master class 1 to slave) ■ 1 MSAC1 connection (acyclical communication, master class 1 to slave) ■ 2 MSAC2 connections (acyclical communication, master class 2 to slave) ■ Device lock: The device can be locked using the hardware or software. ■ Addressing using DIL switches or software ■ GSD, PDM DD, DTM

Modbus RS485

Protocol	RTU / ASCII
Function codes	03, 04, 06, 08, 16, 23
Broadcast support for function codes	06, 16, 23
Output data	16 measured values (value, unit, status), 8 digital values (value, status)
Input data	4 set points (value, unit, status), 4 digital values (value, status), diagnostic information
Supported features	Address can be configured using switch or software

Modbus TCP

TCP port	502
TCP connections	3
Protocol	RTU
Function codes	03, 04, 06, 08, 16, 23

Broadcast support for function codes	06, 16, 23
Output data	16 measured values (value, unit, status), 8 digital values (value, status)
Input data	4 set points (value, unit, status), 6 digital values (value, status), diagnostic information
Supported features	Address can be configured using DHCP or software

EtherNet/IP

Protocol	EtherNet/IP	
ODVA certification	Yes	
Device profile	Generic device (product type: 0x2B)	
Manufacturer ID	0x049E _h	
Device type ID	0x109C _h	
Polarity	Auto-MIDI-X	
Connections (max.)	CIP	12
	I/O	6
	Explicit message	6
	Multicast	3 consumers
Minimum RPI	100 ms (default)	
Maximum RPI	10000 ms	
System integration	EtherNet/IP	EDS
	Rockwell	Add-on-Profile Level 3, Faceplate for FactoryTalk SE
IO data	Input (T --> O)	Device status and diagnostic message with highest priority Measured values: <ul style="list-style-type: none"> ▪ 16 AI (analog input) + Status + Unit ▪ 8 DI (discrete input) + Status
	Output (O --> T)	Actuating values: <ul style="list-style-type: none"> ▪ 4 AO (analog output) + status + unit ▪ 8 DO (discrete output) + Status

Web server

The web server allows complete access to the device configuration, measured values, diagnostic measurements, logbooks and service data via standard WiFi/WLAN/LAN/GSM or 3G router with a user-defined IP address.

TCP port	80
Supported features	<ul style="list-style-type: none"> ▪ Remote-controlled device configuration ▪ Save/restore device configuration ▪ Logbook export (file formats: CSV, FDM) ▪ Access to web server via DTM or Internet Explorer

Power supply

Electrical connection

--> For a detailed wiring diagram, see the Operating Instructions for Liquistation CSF48

Supply voltage

Depending on version:

- 100 to 120/200 to 240 V AC $\pm 10\%$, 50/60 Hz
- 24 V DC $+15/-9\%$

NOTICE**The device does not have a power switch**

- ▶ A fuse with a maximum rating of 10 A must be provided by the customer. Observe the local regulations for installation.
- ▶ For samplers with CSA approval, use a 10 A 250 V AC HBC fuse.

Cable entry

Depending on version:

- 1 x M25, 7 x M20 cable gland
- 1 x M25, 1 x M20 cable gland

Permitted cable diameter:

- M20x1.5 mm: 7 to 13 mm (0.28 to 0.51")
- M25x1.5 mm: 9 to 17 mm (0.20 to 0.67")

Mains fuse

Optional fuses on DIN rail

- T10A (for 24V power supply)
- T3.15A (for 230V power supply)
- T10A (fuse for battery backup)
- For version with cCSAus approval: T4A (for temperature regulator)

Power consumption

- Version with vacuum pump: 290 VA
- Version with peristaltic pump: 290 VA
- Version with sampling assembly: 290 VA
- Version with 24V power supply: 240 W

Power failure

- Power supply via battery (optional): 2 x 12 V, 7.2 Ah, with additional charge controller
 -  Replace batteries with battery type Panasonic LC-R127R2PG1.
- Real-time clock: lithium battery, type CR2032

Performance characteristics

Sampling methods**Vacuum pump / peristaltic pump / sampling assembly:**

- Event sampling
- Single and multiple samples
- Sampling table

Vacuum pump / sampling assembly:

- In proportion to time
- In proportion to volume

Peristaltic pump:

- In proportion to time
- In proportion to volume
- In proportion to flow

Dosing volume**Vacuum pump:**

20 to 350 ml (0.7 to 12 fl.oz.)

Peristaltic pump:

10 to 10,000 ml (0.3 to 340 fl.oz.)

 A sample volume < 20 ml can vary in dosing accuracy and repeatability, depending on the application.

Sampling assembly:

10, 30 or 50 ml (0.3; 1 or 1.7 fl.oz.)

Dosing accuracy**Vacuum pump:**

±5 ml (0.17 fl.oz.) or 5 % of the set volume

Peristaltic pump:

±5 ml (0.17 fl.oz.) or 5 % of the set volume

Sampling assembly:

±2 ml (0.07 fl.oz.) or 5 % of the set volume

Repeatability	<ul style="list-style-type: none"> ▪ Vacuum pump: 5 % ▪ Peristaltic pump: 5 % ▪ Sampling assembly: 5 %
Intake speed (vacuum pump / peristaltic pump)	<p>> 0.5 m/s (> 1.6 ft/s) for ≤ 13 mm (1/2") ID, in accordance with EN 25667, ISO 5667</p> <p>> 0.6 m/s (> 1.9 ft/s) for 10 mm (3/8") ID, in accordance with Ö 5893 (Austrian standard); US EPA</p>
Suction height	<ul style="list-style-type: none"> ▪ Vacuum pump: max. 6 m (20 ft) or max. 8 m (26 ft), depending on the version ▪ Peristaltic pump: Max. 8 m (26 ft)
Hose length	Max. 30 m (98 ft)
Temperature control (optional)	<p>Temperature sensors:</p> <ul style="list-style-type: none"> ▪ Sampling chamber temperature ▪ Sample temperature (optional) ▪ Outside temperature (optional) <p>Temperature regulator:</p> <ul style="list-style-type: none"> ▪ Sample temperature range: 2 to 20 °C (36 to 68 °F) - Factory setting: 4 °C (39 °F) ▪ Automatic defrost system ▪ Cooling speed in accordance with Ö 5893 (Austrian standard): 4 liters of water at 20 °C are cooled to 4 °C in less than 210 minutes ▪ Temperature stability of the sample at 4 °C for the ambient temperature range of -15 to 40 °C (5 to 105 °F)

Installation

Installation instructions

Foundation plan

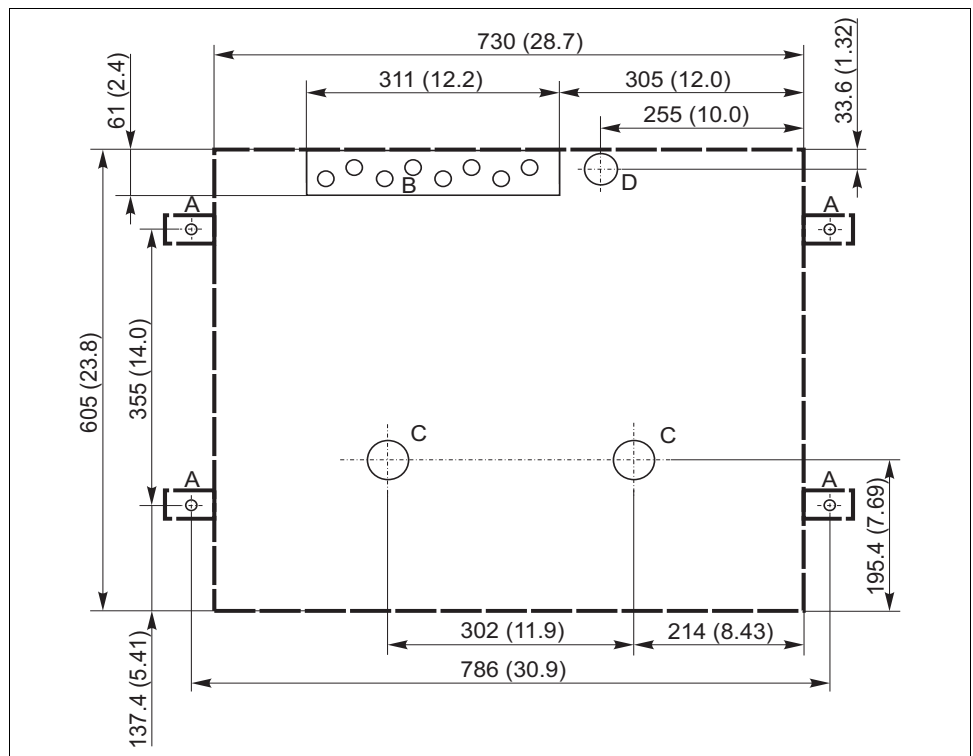

a0012761

Foundation plan

- A Fasteners (4 x M10)
- B Cable inlet
- C Outlet for condensate and overflow > DN 50
- D Sample supply from below > DN 80
- - - Liquistation dimensions

Mounting conditions for Liquistation CSF48

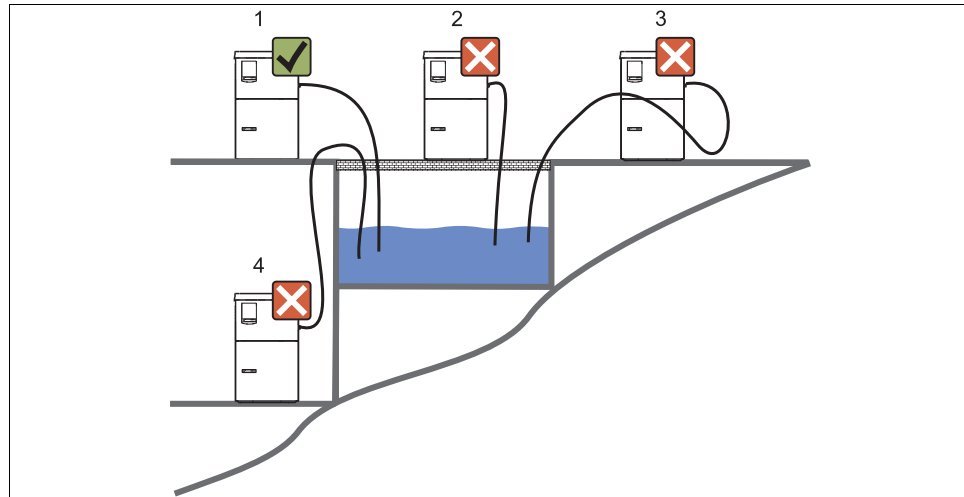

a0011693

Mounting conditions for Liquistation CSF48 for open channels

1. **Correct**
The suction line must be routed with a downward gradient to the sampling point.
2. **Incorrect**
The sampler should never be mounted in a place where it is exposed to aggressive gases.
3. **Incorrect**
Avoid siphoning effects in the suction line.
4. **Incorrect**
The suction pipe should never be routed with an upward gradient to the sampling point.

Note the following when erecting the device:

- Erect the device on a level surface.
- Protect the device against additional heating (e.g. from heaters).
- Protect the device against mechanical vibrations.
- Protect the device against strong magnetic fields.
- Make sure air can circulate freely at the side panels of the cabinet. Do not mount the device directly against a wall. Allow at least 150 mm (5.9") from the wall to the left and right.
- Do not mount the device directly above the inlet channel of a wastewater treatment plant.

Installation conditions for Samplefit CSA420 sampling assembly

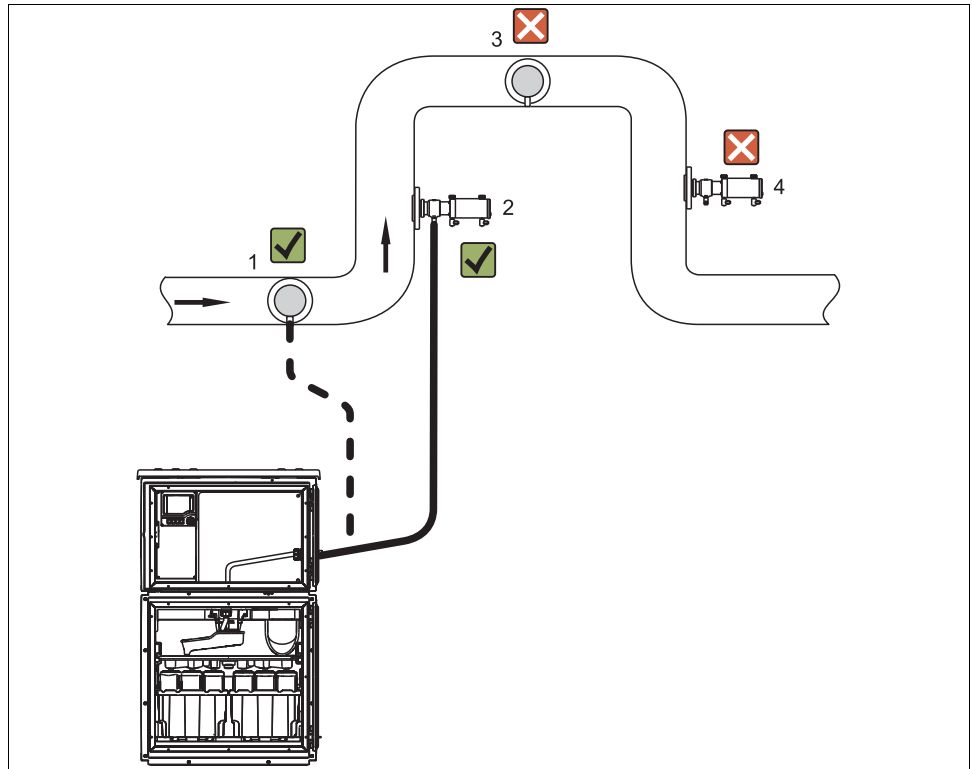

Installation conditions for Liquistation CSF48 with Samplefit CSA420 sampling assembly

Note the following when installing the sampling assembly in a pipe:

- The best installation location is in the ascending pipe (pos. 2). Installation is also possible in the horizontal pipe (pos. 1).
- Avoid installation in the down pipe (pos. 4).
- Avoid siphoning effects in the suction line.
- The minimum vertical distance between the assembly and the inlet of the sampler must be at least 0.5 m (1.65 ft).

Note the following when erecting the sampler:

- Erect the device on a level surface.
- Protect the device against additional heating (e.g. from heaters).
- Protect the device against mechanical vibrations.
- Protect the device against strong magnetic fields.
- Make sure air can circulate freely at the side panels of the cabinet. Do not mount the device directly against a wall. Allow at least 150 mm (5.9") from the wall to the left and right.
- Do not erect the device directly above the inlet channel of a wastewater treatment plant.

Environment

Ambient temperature range	<ul style="list-style-type: none"> ■ With temperature regulator -20 to 40 °C (0 to 100 °F) ■ Without temperature regulator 0 to 40 °C (32 to 100 °F) ■ For ASA+PC or stainless steel housing: -20 to 40 °C (0 to 100 °F) ■ For plastic polystyrene housing: 0 to 40 °C (32 to 100 °F)
Storage temperature	-20 to 60 °C (0 to 140 °F)
Degree of protection	<ul style="list-style-type: none"> ■ Dosing compartment (front): IP 54 ■ Dosing compartment (back): IP 34 ■ Control (front panel): IP 65 ■ Sample compartment: IP 54
Electromagnetic compatibility	Interference emission and interference immunity as per EN 61326-1: 2006, class A for industry
Electrical safety	In accordance with EN 61010-1, protection class I, environment ≤ 2000 m (6500 ft) above MSL. The device is designed for contamination level 2.
Relative humidity	10 to 95%, not condensing

Process

Medium temperature range	2 to 50 °C (36 to 122 °F)
Medium properties	<p>Liquistation with vacuum pump Capacitance level measurement used for:</p> <ul style="list-style-type: none"> ■ Media that tend to create a lot of foam or contain fats and grease ■ Media with a conductivity < 30 µS/cm <p>Liquistation with peristaltic pump</p> <ul style="list-style-type: none"> ■ Sample media have to be free of abrasive substances. <p>Liquistation with sampling assembly</p> <ul style="list-style-type: none"> ■ Sample media have to be free of abrasive substances. ■ For sample media with a solids content of >1 %, no plate distribution can be used. The sample must be filled directly into a bottle or container. <p>Caution! Pay attention to the material resistance of the wetted parts.</p>
Process pressure	<p>Vacuum pump / peristaltic pump:</p> <ul style="list-style-type: none"> ■ unpressurized, open channel ■ max. 0.8 bar piping (only with shutoff / inlet valve) <p>Sampling assembly:</p> <ul style="list-style-type: none"> ■ max. 6 bar
Process connection	<ul style="list-style-type: none"> ■ Vacuum pump: Intake hose ID 10 mm (3/8"), 13 mm (1/2"), 16 mm (5/8") or 19 mm (3/4") ■ Peristaltic pump: Intake hose ID 10 mm (3/8") ■ Sampling assembly: <ul style="list-style-type: none"> - Flange DN50, PP - Triclamp DN50, DIN 32676

Process connection
Samplefit CSA420 sampling
assembly

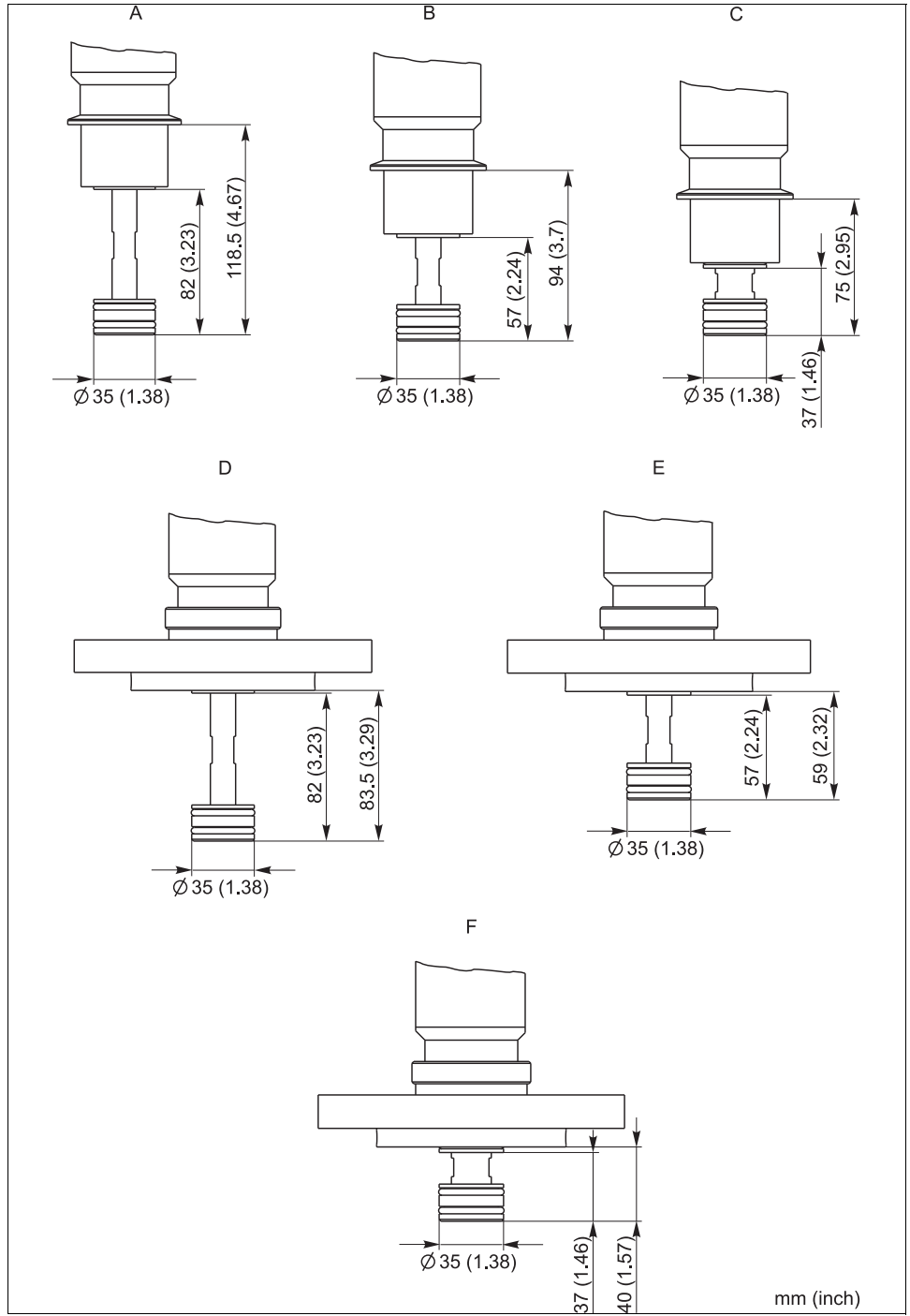

a0016245

Process connections, Samplefit CSA420 sampling assembly

- A Triclamp DN50, 50ml version
- B Triclamp DN50, 30ml version
- C Triclamp DN50, 10ml version
- D Flange DN50, 50ml version
- E Flange DN50, 30ml version
- F Flange DN50, 10ml version

Mechanical construction

Dimensions

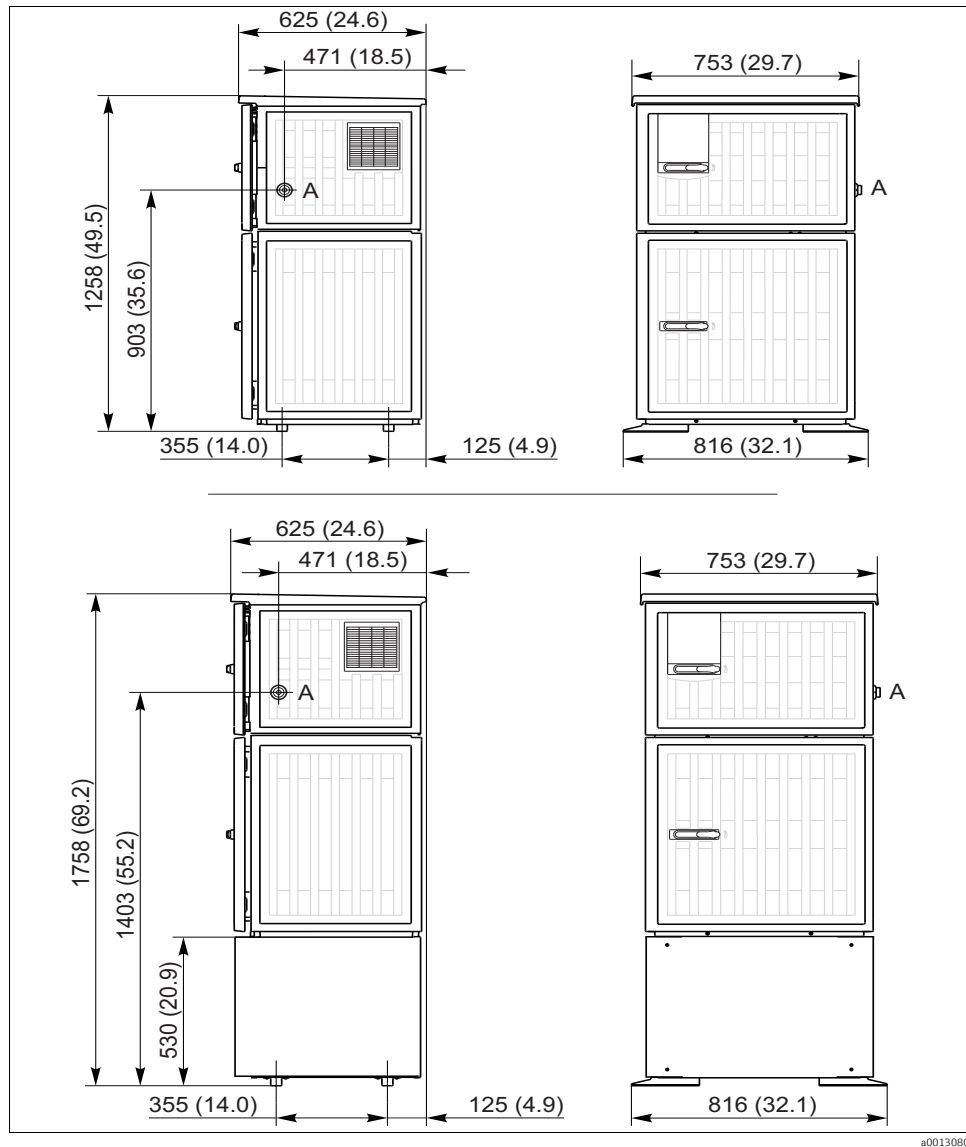

Dimensions of plastic version of Liquistation CSF48 without/with stand

A Suction line connection

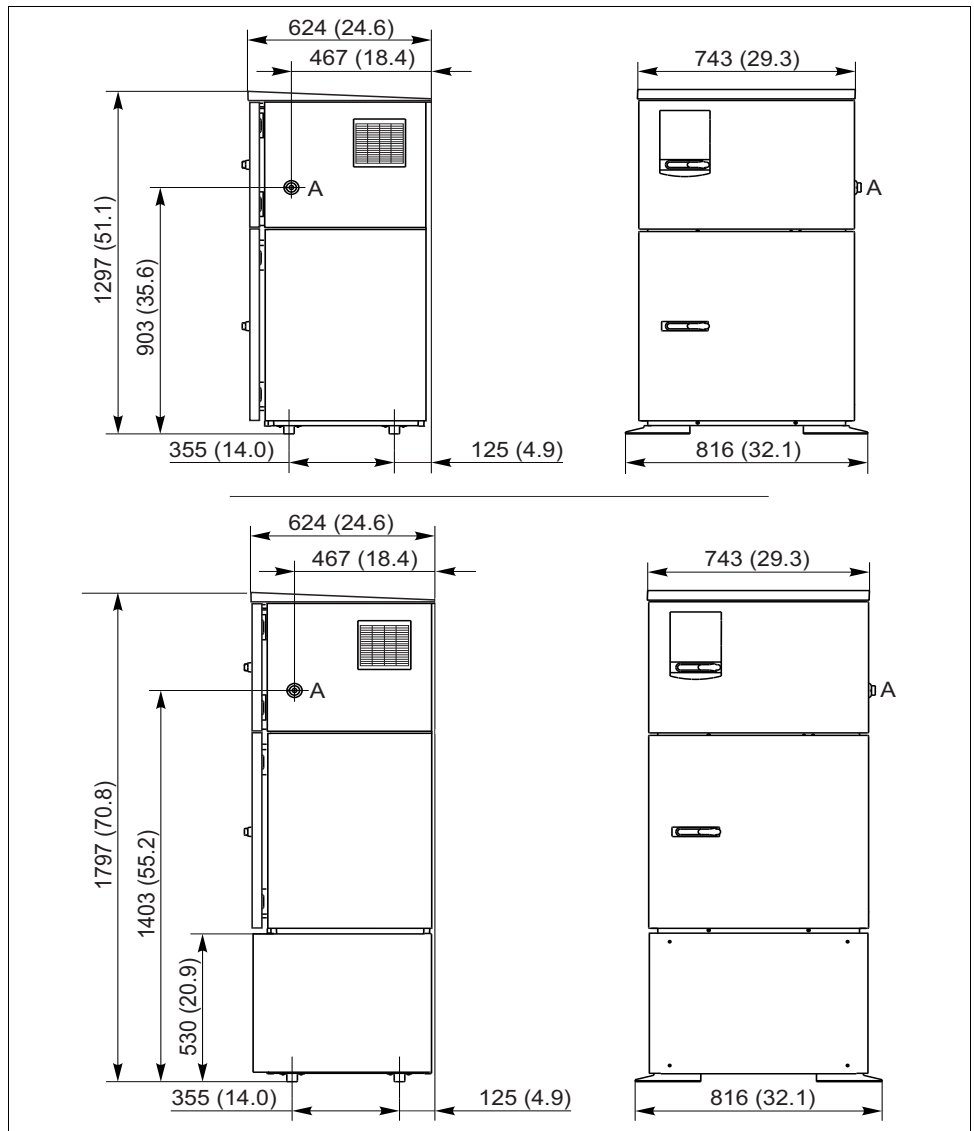

a0013082

Dimensions of stainless steel version of Liquistation CSF48 without/with stand

A Suction line connection

Weight

CSF48 sampler version	Weight
Plastic version without cooling module	91 kg (201 lbs)
Plastic version with cooling module	101 kg (223 lbs)
Plastic version without cooling module and with fixed castor frame	105 kg (232 lbs)
Stainless steel version with cooling module	118 kg (260 lbs)
Stainless steel version with stand and cooling module	146 kg (322 lbs)

Material

- i** Plastic polystyrene V0 can change color when exposed to direct sunlight. For outdoor use without a weather protection cover, the use of Plastic ASA+PC V0 is recommended.
The functionality is not affected by the discoloration.

Non-wetted parts	
Cabinet housing	<p>Plastic polystyrene V0 For standard applications in wastewater treatment plants and environmental monitoring</p> <p>Plastic ASA+PC V0 For industrial wastewater treatment plants with an aggressive atmosphere</p> <p>Stainless steel V2A (1.4301) For standard applications in wastewater treatment plants and environmental monitoring</p> <p>Stainless steel V4A (1.4571) For industrial wastewater treatment plants with an aggressive atmosphere</p>
Sample compartment inner dish	Plastic PP
Window	Safety glass, coated
Insulation	Plastic EPS "Neopor®"

Wetted parts	Vacuum pump	Peristaltic pump	Sampling assembly:
Dosing tube	Plastic PP	-	-
Dosing beaker cover	Plastic PP	-	-
Conductivity sensors	Stainless steel V4A (1.4404)	-	-
Capacitance sensor	PSU	-	-
Dosing beaker	PMMA, glass (depending on version)	-	-
Dosing system outflow hose	Silicone	-	EPDM
Pump tubing	-	Silicone	-
Process seal	-	-	Viton EPDM Kalrez
Distribution arm	Plastic PP		
Distribution arm cover	Plastic PE		
Distribution plate	Plastic PS		
Composite container/bottles	Plastic PE, glass (depending on version)		
Intake hose	Plastic PVC, EPDM (depending on version)		-
Hose connection	Plastic PP		-
Rinse connection	-	-	Plastic PP

- i** Choose process seal depending on the application.
Viton is recommended for standard applications involving watery samples.

Operability

Operating concept

The simple and structured operating concept sets new standards:

- Intuitive operation with the navigator and soft keys
- Fast configuration of application-specific measurement options
- Easy configuration and diagnosis thanks to plain-text display
- All languages that can be ordered are available in every device

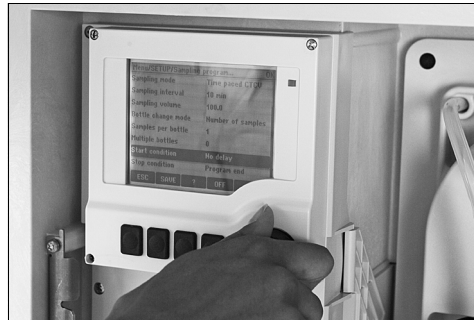

Easy operation

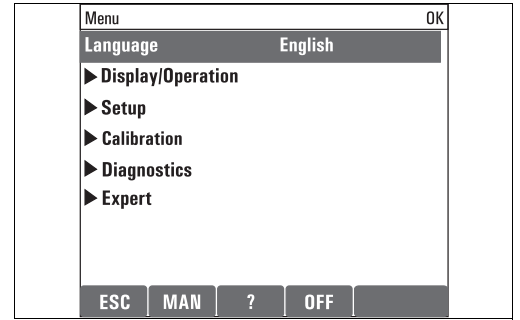

Plain-text menu

Display

Graphic display:

- Backlight with switch-off function
- Red display background for alarms alerts users to errors
- Transflective display technology for maximum contrast even in bright environments
- User-definable measuring menus mean you can always keep track of the values that are important for your application.

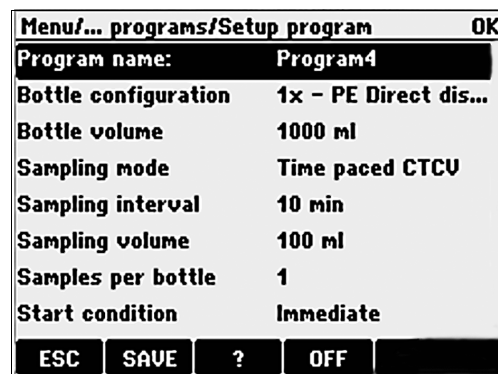

Example of program setup

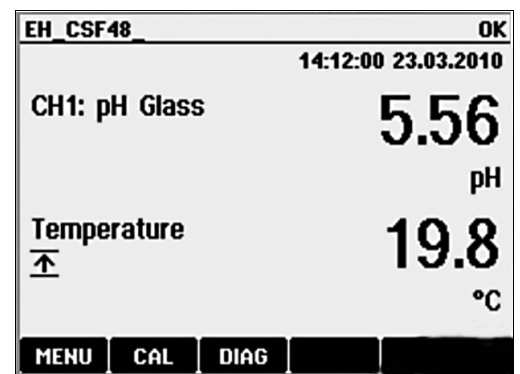

Example of measuring menus

Local operation

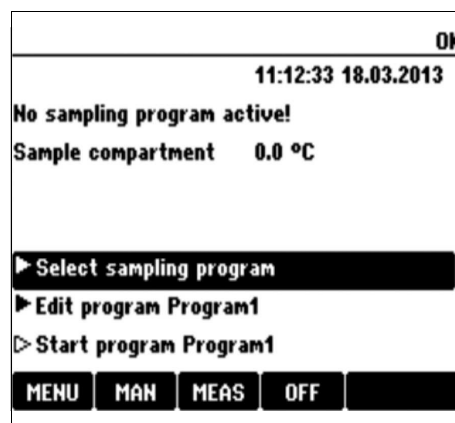

a0013322

- Liquid crystal display, backlighting
- 160 x 240 pixels
- 4 operating keys (soft key function) and navigator
- Menu-guided operation

Remote operation

Via HART (e.g. via HART modem and FieldCare)

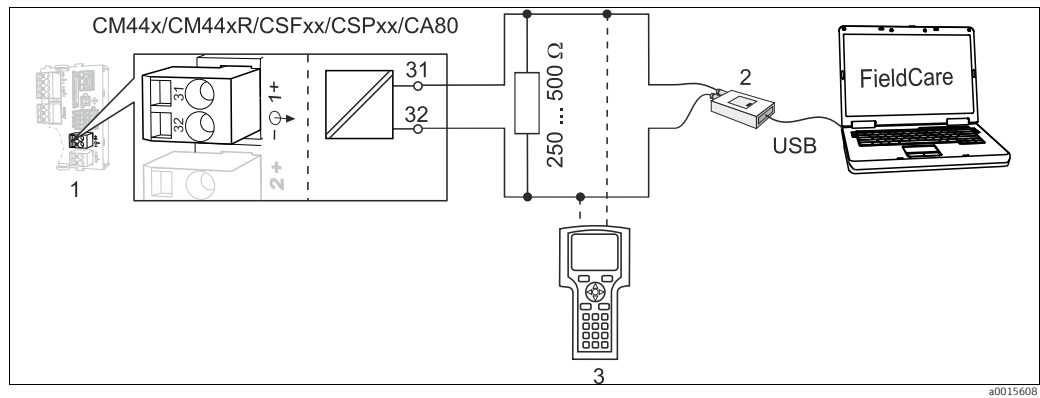

a0015608

HART via modem

- 1 Base L or E device module: Current output 1 with HART
- 2 HART modem for connection to PC, e.g. Commubox FXA191 (RS232) or FXA195¹⁾ (USB)
- 3 HART handheld terminal

Via PROFIBUS DP

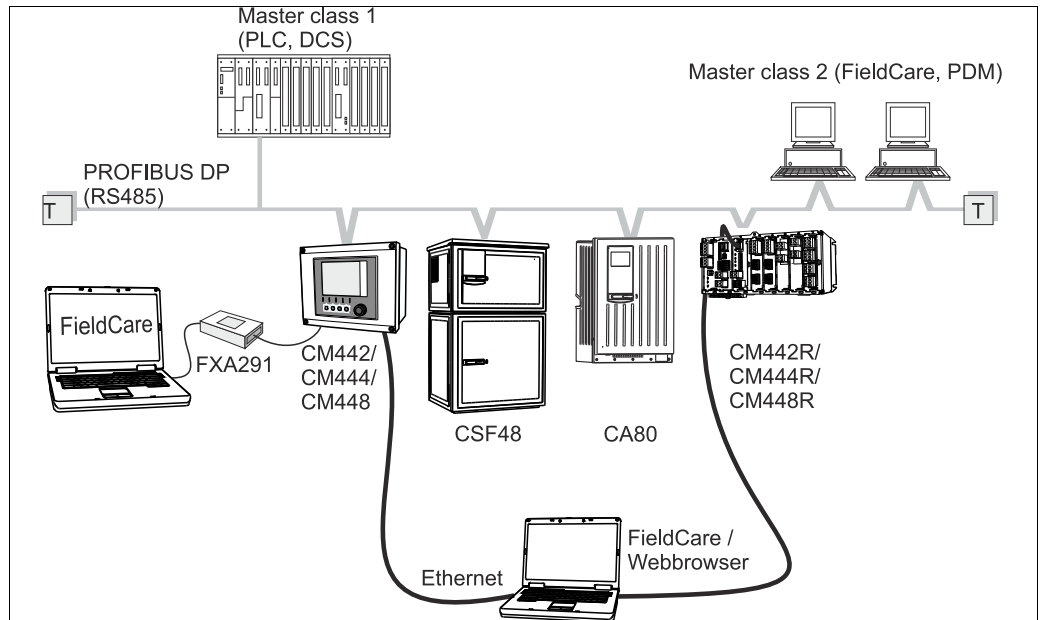

a0015874

PROFIBUS DP

- T Terminating resistor

1) Switch position "on" (replaces resistance)

Via Modbus RS485

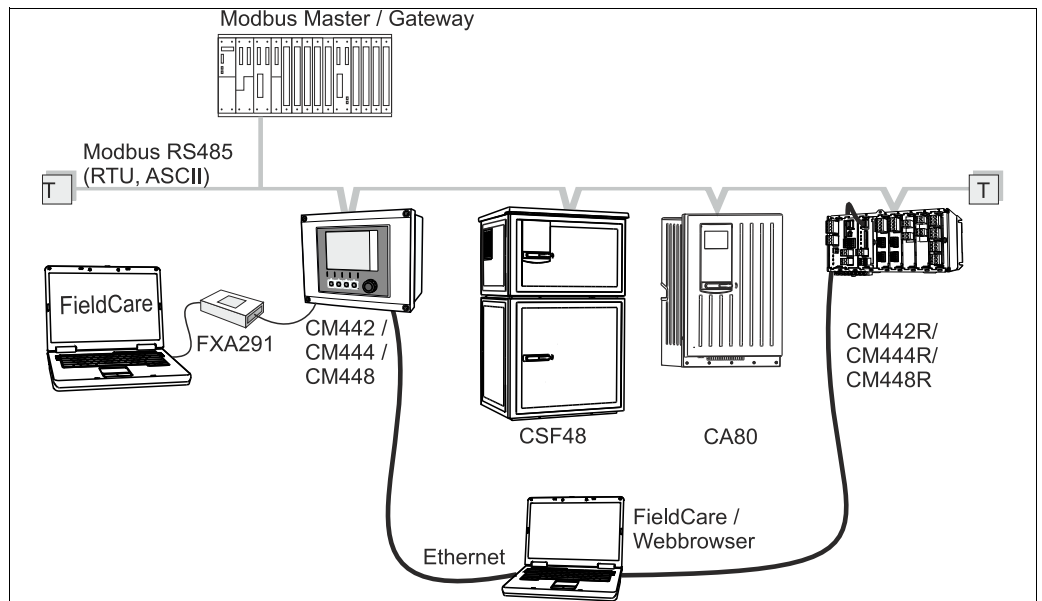

a0015875

Modbus RS485

T Terminating resistor

Via Ethernet/web server/Modbus TCP/EtherNet/IP

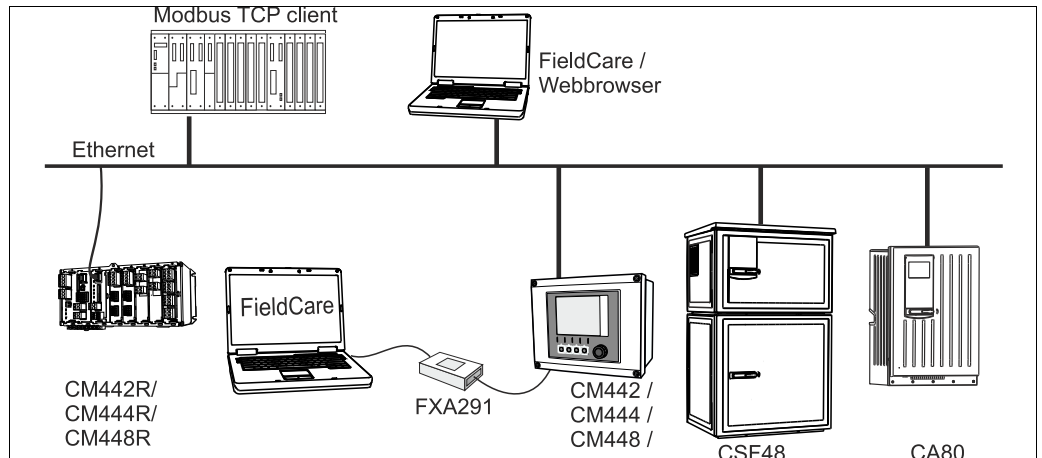

a0015876

Modbus TCP and / or Ethernet

Communication

- 1 service interface
- Optionally on front panel
- Commubox FXA291 (accessory) required for communication with the PC

Software

Field Data Manager

- Standardized user interface under Windows®
- Reading out the internal memory containing the measured flow rate, sample volume taken etc.

FieldCare

- Device settings saved in a database
- Configuration

Ordering information

Product structure

You can create a valid and complete order code online using the Configurator.

Enter the following URLs in your browser to access the relevant product page:

www.products.endress.com/csf48

www.products.endress.com/csa420

1. You can choose from the following options on the right of the product page:

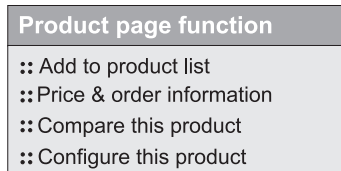

2. Click "Configure this product".
3. The Configurator opens in a separate window. You can now configure your device and you will receive the complete order code valid for that device.
4. Now export the order code as a PDF file or Excel file. To do so, click the appropriate button at the top of the page.

Scope of delivery

The scope of delivery comprises:

- 1 Liquistation CSF48 with:
 - The ordered bottle configuration
 - Optional hardware
- Accessories kit
 - For peristaltic or vacuum pump:
 - Connection nipple for suction line with various angles (straight, °90°), Allen key (for version with vacuum pump only)
 - For sampling assembly:
 - 2 or 3 compressed air pipes, 5 m each, 1 suction pipe EPDM 13 mm ID, 5 m
- 1 "Commissioning" Operating Instructions
(In the preferred language if the "Default operating language" order option is selected. Otherwise, the Brief Operating Instructions supplied are in English)
- 1 CD-ROM with Operating Instructions in all available languages, an application handbook and simulation software
- Optional accessories

Certificates and approvals

CE mark

Declaration of Conformity

The product meets the requirements of the harmonized European standards.

As such, it complies with the legal specifications of the EC directives.

The manufacturer confirms successful testing of the product by affixing to it the **CE** mark.

MCERTS

The device has been assessed by Sira Certification Service and complies with "MCERTS Performance Standards for Water Monitoring Equipment Part 1, Version 2.1 dated November 2009"; certificate no.: Sira MC100176/00.

cCSAus

cCSAus General purpose

The product meets the requirements in accordance with "Class 8721 05, laboratory equipment, electrical; Class 8721 85, laboratory equipment, electrical, certified to US standards" for indoor use. Certificate no.: 2318018

Accessories

i The most important accessories that could be delivered at the time this document went to print are listed below.

For accessories not listed here, please contact your service department or sales center.

Accessories for Liquistation CSF48

Order no.	Bottle tray + bottles + cover
71162811	Bottle tray + 2 x 3.8 liter (1.00 US gal.) glass + cover
71134282	Bottle tray + 6 x 1.8 liter (0.48 US gal.) glass + cover
71111152	Bottle tray + 6 x 3 liter (0.79 US gal.) PE+ cover
71111153	Bottle tray + 12 x 1 liter (0.26 US gal.) glass + cover
71111154	Bottle tray + 12 x 1 liter (0.26 US gal.) PE + cover
71111155	Bottle tray + 12 x 2 liter (0.53 US gal.) PE angular bottle + cover
71111156	Bottle tray + 24 x 1 liter (0.26 US gal.) PE angular bottle + cover
71111157	Bottle tray + 12 x 1 liter (0.26 US gal.) + 6 x 2 liter (0.53 US gal.) PE angular bottle + cover
71185981	Bottle tray + 12 x 2 Liter (0.53 US gal.) square-shaped PE + cover
Distribution plate; locating insert	
71111158	Distribution plate for 2 x 6 bottles
71111159	Distribution plate for 2 x 12 bottles
71111160	Distribution plate for 1-2 + 6 bottles
71111161	Distribution plate for 1-2 + 12 bottles
71111162	Distribution plate for 6 + 12 bottles
71185983	Distribution plate for 2 x 12 bottles, 2 liter, PE
71185984	Distribution plate for 1-2 + 12 bottles, 2 liter, PE
71111163	Locating insert for bottle tray with angular bottles
71186013	Locating insert for 4 x 5 liter Schott bottles DURAN GLS 80
Bottles + covers	
71111164	1 liter (0.26 US gal.) PE + cover, 24 pcs.
71111165	1 liter (0.26 US gal.) glass + cover, 24 pcs.
71134277	1.8 liter (0.48 US gal.) glass + cover, 6 pc.
71185985	2 liter (0.53 US gal.) PE, square-shaped + cover, 24 pcs
71111167	3 liter (0.79 US gal.) PE + cover, 12 pcs.
71162812	3.8 liter (1.00 US gal.) glass + cover, 1 pc.
71111169	13 liter (3.43 US gal.) PE + cover, 1 pc.
71146645	17 liter (4.49 US gal.) PE, 1 pc.
71111170	25 liter (5.28 US gal.) PE + cover, 1 pc.
71111172	30 liter (7.92 US gal.) PE + cover, 1 pc.
71111173	60 liter (15.8 US gal.) PE + cover, 1 pc.
71111176	1 liter (0.26 US gal.) PE angular bottle + cover, 24 pcs.
71111178	2 liter (0.53 US gal.) PE angular bottle + cover, 12 pcs.
Complete suction line	
71111233	Suction line ID 10 mm (3/8"), PVC clear, reinforced fabric, length 10 m (33 ft), suction head V4A
71111234	Suction line ID 10 mm (3/8"), EPDM black, length 10 m (33 ft), suction head V4A
71111235	Suction line ID 13 mm (1/2"), PVC green, reinforced spiral wire, length 10 m (33 ft), suction head V4A
71111236	Suction line ID 13 mm (1/2"), EPDM black, length 10 m (33 ft), suction head V4A
71111237	Suction line ID 16 mm (5/8"), PVC green, reinforced spiral wire, length 10 m (33 ft), suction head V4A
71111238	Suction line ID 16 mm (5/8"), EPDM black, length 10 m (33 ft), suction head V4A
71111239	Suction line ID 19 mm (3/4"), PVC green, reinforced spiral wire, length 10 m (33 ft), suction head V4A
71111240	Suction line ID 19 mm (3/4"), EPDM black, length 10 m (33 ft), suction head V4A
Suction line coil	
71111482	... m, suction line ID 10 mm (3/8"), PVC clear
71111484	... m, suction line ID 10 mm (3/8"), EPDM black
71111485	... m, suction line ID 13 mm (1/2"), PVC green
71111486	... m, suction line ID 13 mm (1/2"), EPDM black
71111487	... m, suction line ID 16 mm (5/8"), PVC green
71111481	... m, suction line ID 16 mm (5/8"), EPDM black
71111488	... m, suction line ID 19 mm (3/4"), PVC green
71111489	... m, suction line ID 19 mm (3/4"), EPDM black
71111490	... m, suction line ID 32 mm (1 1/4"), PVC green
Suction head	
71111184	Suction head V4A for ID 10 mm (3/8"), 1 pc.
71111185	Suction head V4A for ID 13 mm (1/2"), 1 pc.
71111186	Suction head V4A for ID 16 mm (5/8"), 1 pc.
71111187	Suction head V4A for ID 19 mm (3/4"), 1 pc.

Terminated hose; vacuum pump	
71111188	Dosing hose to distributor, 2 pcs, material: silicon
71111189	Dosing hose to distributor, 25 pcs, material: silicon
Terminated hose; peristaltic pump	
71111191	Pump tubing, 2 pcs; material: silicon
71111192	Pump tubing, 25 pcs; material: silicon
Communication; software	
71110815	SD card, 1 GB, Industrial Flash Drive
51516983	Commubox FXA291 + FieldCare Device Setup
71129799	Field Data Manager software; 1 license, analysis report
71127100	SD card with Liquiline firmware, 1 GB, industrial flash drive
71128428	Activation code for digital HART communication
71135635	Activation code for PROFIBUS DP
71135636	Activation code for Modbus RS485
71135637	Activation code for Modbus TCP
Retrofit kits	
71111195	Kit CSF48: Retrofit kit distribution assembly (distribution arm, distribution drive)
71111196	Kit CSF48: Retrofit kit casters
71111197	Kit CSF48: Retrofit kit stand, V2A; 304(x)
71111198	Kit CSF48: Retrofit kit stand, V4A; 316(x)
71111199	Kit CSF48: Retrofit kit for flow assembly, without stand, with stand cover V2A; 304(x)
71111200	Kit CSF48: Retrofit kit for flow assembly, without stand, with stand cover V4A; 316(x)
71111205	Kit CSF48: Retrofit kit for temperature sensor PT1000
71111206	Kit CSF48: Retrofit kit 1x digital sensor, Memosens protocol + 2x output 0/4-20mA (hardware + software)
71111208	Kit CSF48: Retrofit kit 2x digital sensor, Memosens protocol + 2x output 0/4-20mA (hardware + software)
71111210	Kit CSF48: Retrofit kit 1x to 2x digital sensor, Memosens protocol + 2x output 0/4-20mA (software)
71146969	Kit CSF48: Retrofit kit 2x digital sensor + 2x output 0/4-20mA and extension backplane
71136999	Kit CSF48: Retrofit kit service interface (CDI flange connector, counter nut)
71136885	Kit CSF48: Retrofit kit relay (2x + cable set)
71136101	Kit CSF48: Retrofit kit door stop (2x)
71184459	Kit CSF48: Retrofit kit BASE-E module + backplane extension
71207321	Kit CSF48: Sample distribution 24 x 2 liter
71111053	Kit CM442/CM444/CM448/CSF48: Extension module AOR; 2 x relay, 2 x analog output 0/4 to 20 mA
71125375	Kit CM442/CM444/CM448/CSF48: Extension module 2R; 2 x relay
71125376	Kit CM442/CM444/CM448/CSF48: Extension module 4R; 4 x relay
71135632	Kit CM442/CM444/CM448/CSF48: Extension module 2AO; 2 x analog output 0/4 to 20 mA
71135633	Kit CM442/CM444/CM448/CSF48: Extension module 4AO; 4 x analog output 0/4 to 20 mA
71135631	Kit CM444/CM448/CSF48: Extension module 2DS; 2 x digital sensor, Memosens
71135634	Kit CM442/CM444/CM448/CSF48: Extension module 485; Ethernet configuration; with activation code extensible to PROFIBUS DP or Modbus RS485 or Modbus TCP or EtherNet/IP
71135638	Kit CM444/CM448/CSF48: Extension module DIO; 2 x digital input, 2 x digital output, auxiliary power supply for digital output
71140888	Upgrade kit CM442/CM444/CM448/CSF48; Extension module 485; PROFIBUS DP (+ Ethernet configuration)
71140889	Upgrade kit CM442/CM444/CM448/CSF48; Extension module 485; Modbus RS485 (+ Ethernet configuration)
71140890	Upgrade kit CM442/CM444/CM448/CSF48; Extension module 485; Modbus TCP (+ Ethernet configuration)
71140891	Kit CM444/CM448: Upgrade code for 2 x 0/4 to 20 mA for BASE-E
71128428	Activation code for digital HART communication

Accessories for parameter measurements

Sensors

Glass electrodes

Orbisint CPS11D

- pH sensor with Memosens technology
- Dirt-repellent PTFE diaphragm
- Order as per product structure (--> Online Configurator, www.products.endress.com/cps11d)
- Technical Information TI028C/07/EN

Ceraliquid CPS41D

- pH sensor with Memosens technology
- Ceramic diaphragm and KCl liquid electrolyte
- Order as per product structure (--> Online Configurator, www.products.endress.com/cps41d)
- Technical Information TI079C/07/EN

Ceragel CPS71D

- pH sensor with Memosens technology
- Double-chamber reference system and integrated bridge electrolyte
- Order as per product structure (--> Online Configurator, www.products.endress.com/cps71d)
- Technical Information TI245C/07/EN

Orbipore CPS91D

- pH sensor with Memosens technology
- Open aperture diaphragm for media with high dirt load
- Order as per product structure (--> Online Configurator, www.products.endress.com/cps91d)
- Technical Information TI375C/07/EN

Memosens CPS16D

- Combined pH/ORP sensor for process technology, with dirt-repellent PTFE diaphragm
- With Memosens technology
- Order as per product structure (--> Online Configurator, www.products.endress.com/cps16d)
- Technical Information TI00503C/07/EN

Memosens CPS76D

- Combined pH/ORP sensor for process technology, hygiene and sterile applications
- With Memosens technology
- Order as per product structure (--> Online Configurator, www.products.endress.com/cps76d)
- Technical Information TI00506C/07/EN

Memosens CPS96D

- Combined pH/ORP sensor for chemical processes
- With poison-resistant reference with ion trap
- With Memosens technology
- Order as per product structure (--> Online Configurator, www.products.endress.com/cps96d)
- Technical Information TI00507C/07/EN

Orbipac CPF81D

- Compact pH sensor for installation or immersion operation in process water and wastewater
- Order as per product structure (--> Online Configurator, www.products.endress.com/cpf81d)
- Technical Information TI191C/07/EN

Pfudler electrodes**Ceramax CPS341D**

- pH electrode with pH-sensitive enamel
- Meets toughest requirements for accuracy, pressure, temperature, sterility and durability
- Order as per product structure (--> Online Configurator, www.products.endress.com/cps341d)
- Technical Information TI468C/07/EN

ORP sensors**Orbisint CPS12D**

- ORP sensor with Memosens technology
- Dirt-repellent PTFE diaphragm;
- Order as per product structure (--> Online Configurator, www.products.endress.com/cps12d)
- Technical Information TI367C/07/EN

Ceraliquid CPS42D

- ORP sensor with Memosens technology
- Ceramic diaphragm and KCl liquid electrolyte
- Order as per product structure (--> Online Configurator, www.products.endress.com/cps42d)
- Technical Information TI373C/07/EN

Ceragel CPS72D

- ORP sensor with Memosens technology
- Double-chamber reference system and integrated bridge electrolyte;
- Order as per product structure (--> Online Configurator, www.products.endress.com/cps72d)
- Technical Information TI374C/07/EN

Orbipac CPF82D

- Compact pH sensor for flow or immersion operation in process water and wastewater
- Order as per product structure (--> Online Configurator, www.products.endress.com/cpf82d)
- Technical Information TI191C/07/EN

Orbipore CPS92D

- ORP sensor with Memosens technology
- Open aperture diaphragm for media with high dirt load
- Order as per product structure (--> Online Configurator, www.products.endress.com/cps92d)
- Technical Information TI435C/07/EN

pH ISFET sensors**Tophit CPS471D**

- Sterilizable and autoclavable ISFET sensor with Memosens technology
- For the food and pharmaceutical industries, process engineering, water treatment and biotechnology
- Order as per product structure (--> Online Configurator, www.products.endress.com/cps471d)
- Technical Information TI283C/07/EN

Tophit CPS441D

- Sterilizable ISFET sensor with Memosens technology
- For media with low conductivity, with liquid KCl electrolyte
- Order as per product structure (--> Online Configurator, www.products.endress.com/cps441d)
- Technical Information TI352C/07/EN

Tophit CPS491D

- ISFET sensor with Memosens technology
- Open aperture diaphragm for media with high dirt load
- Order as per product structure (--> Online Configurator, www.products.endress.com/cps491d)
- Technical Information TI377C/07/EN

Inductively measuring conductivity sensors**Indumax CLS50D**

- High-stability inductive conductivity sensor for standard, Ex and high-temperature applications
- Memosens protocol
- Order as per product structure (--> Online Configurator, www.products.endress.com/cls50d)
- Technical Information TI182C/07/EN

Conductively measuring conductivity sensors**Condumax CLS15D**

- Conductive conductivity sensor for pure and ultra-pure water and Ex applications
- Order as per product structure (--> Online Configurator, www.products.endress.com/cls15d)
- Technical Information TI109C/07/EN

Condumax CLS16D

- Hygienic, conductive conductivity sensor for pure and ultra-pure water and Ex applications
- With EHEDG and 3A approval
- Order as per product structure (--> Online Configurator, www.products.endress.com/cls16d)
- Technical Information TI227C/07/EN

Condumax CLS21D

- Two-electrode sensor in plug-in head and fixed cable version
- Order as per product structure (--> Online Configurator, www.products.endress.com/cls21d)
- Technical Information TI085C/07/EN

Oxygen sensors**Oxymax COS51D**

- Amperometric sensor for dissolved oxygen, with Memosens technology
- Order as per product structure (--> Online Configurator, www.products.endress.com/cos51d)
- Technical Information TI413C/07/EN

Oxymax COS61D

- Optical oxygen sensor for drinking water and industrial water measurement
- Measuring principle: quenching
- Memosens protocol
- Material: stainless steel 1.4571 (AISI 316Ti)
- Order as per product structure (--> Online Configurator, www.products.endress.com/cos61d)
- Technical Information TI387C/07/EN

Oxymax COS22D

- Sterilizable sensor for dissolved oxygen
- Order as per product structure (--> Online Configurator, www.products.endress.com/cos22d)
- Technical Information TI446C/07/EN

Chlorine sensors**CCS142D**

- Membrane-covered amperometric sensor for free chlorine
- Memosens technology
- Measuring range 0.01 to 20 mg/l
- Order as per product structure (--> Online Configurator, www.products.endress.com/ccs142d)
- Technical Information TI419C/07/EN

Ion-selective sensors**ISEmax CAS40D**

- Ion-selective sensors
- Order as per product structure (--> Online Configurator, www.products.endress.com/cas40d)
- Technical Information TI491C/07/EN

Turbidity sensors**Turbimax CUS51D**

- For nephelometric measurement of turbidity and solids in wastewater
- 4-beam scattered light method
- With Memosens protocol
- Order as per product structure (--> Online Configurator, www.products.endress.com/cus51d)
- Technical Information TI461C/07/EN

SAC and nitrate sensors**Viomax CAS51D**

- SAC and nitrate measurement in drinking water and wastewater
- With Memosens protocol
- Order as per product structure (--> Online Configurator, www.products.endress.com/cas51d)
- Technical Information TI459C/07/EN

Interface measurement**Turbimax CUS71D**

- Immersion sensor for interface measurement
- Ultrasonic interface sensor
- Order as per product structure (--> Online Configurator, www.products.endress.com/cus71d)
- Technical Information TI490C/07/EN

Measuring cable**Memosens data cable****CYK10**

- For digital sensors with Memosens technology
pH, ORP, oxygen (amperometric), chlorine, conductivity (conductive)
- Order as per product structure (--> Online Configurator, www.products.endress.com/cyk10)

Measuring cable CYK81

- Unterminated cable for extending the sensor cables (e.g. Memosens)
- 2 x 2 wires, twisted with shield and PVC sheath (2 x 2 x 0.5 mm² + shield)
- Goods sold by meter, Order no.: 51502543

www.addresses.endress.com
