

## Technical Information

# Oil Leak Detector NAR300 System High Temperature



### Application

This system is set up in a pit, dike or plant, or sump pit near the pump yard, where it provides the ultimate leak detection function for petrochemicals or vegetable oils. The Oil Leak Detector NAR300 System for high temperature utilizes conductivity detection principle to monitor the condition.

This NAR300 system for high temperature is suitable for a pit using steam draining conduit for antifreezing and high temperatures ( $\leq 100^{\circ}\text{C}$ ).

The accurate and minimal equipment configuration ensures safe operation of the tank yard.

### Flame proof System:

Alarm output transmitted to Host controller via connected Transmitter NRR261 (outdoor installation) and e.g. level transmitter with switching input

### Intrinsically safe System:

Direct alarm output to host controller when connected in combination with Transmitter NRR262 (indoor installation).

### Features and benefits

- Conductive sensor detects presence of conductive liquid
- No moving parts, low maintenance, long life
- Safe operation assured via advanced diagnostics that power fail, frozen pit-liquid, etc.
- Independent of dielectric constant when detecting water-insoluble oils
- Improved performance even in harsh pit conditions
- Intrinsically float sensor
- EMC-compliant

## Table of Contents

<b>Function and system design</b> .....	<b>3</b>	<b>Specifications</b> .....	<b>18</b>
IS system:Ex ia IIB T4 .....	3	Float sensor NAR300 .....	18
Ex d[ia]system: Ex d[ia]IIB T4 .....	3	Sensor I/F Ex box .....	18
<b>Operating Principle</b> .....	<b>4</b>	Transmitter NRR261 .....	18
Detection Principle .....	4	Transmitter NRR262 .....	19
Alarm principle .....	5	<b>Process Conditions</b> .....	<b>20</b>
<b>Operating conditions</b> .....	<b>7</b>	Float sensor NAR300 .....	20
Detection Sensitivity .....	7	Sensor I/F Ex box .....	20
Water-filled pits .....	7	Transmitter NRR261 .....	20
Gasolin application .....	7	Transmitter NRR262 .....	21
<b>Installation</b> .....	<b>8</b>	<b>Accessory</b> .....	<b>22</b>
<b>Dimensions</b> .....	<b>9</b>	Float guide .....	22
Float sensor NAR300 .....	9	U bolt and cable gland .....	22
Ex d [ia] Transmitter NRR261 .....	10	<b>Certificates and approvals</b> .....	<b>23</b>
Ex ia Transmitter NRR262 .....	10	Ex approval .....	23
Ex ia Sensor I/F Ex box .....	11	<b>Documentation</b> .....	<b>23</b>
<b>Electrical connection</b> .....	<b>12</b>	Operating Instructions .....	23
Grounding cable .....	12	Safety Instructions .....	23
Ex ia transmitter NRR262-2x .....	13		
Ex d[ia] transmitter NRR261-3xx .....	14		
Connection diagram .....	15		
<b>Ordering Information</b> .....	<b>16</b>		
Float Sensor NAR300 .....	16		
Transmitter NRR261 .....	17		
Transmitter NRR262 .....	17		

## Function and system design

**IS system:  
Ex ia IIB T4**

The intrinsically safe system includes the intrinsically safe transmitter NRR262, which is installed indoors in a non-Ex area, and outputs a signal to an alarm panel or host system located indoors. The signal from NAR300 is output to the transmitter NRR262 via the sensor interface Ex box by a special cable supplied as part of the sensor by Endress+Hauser.

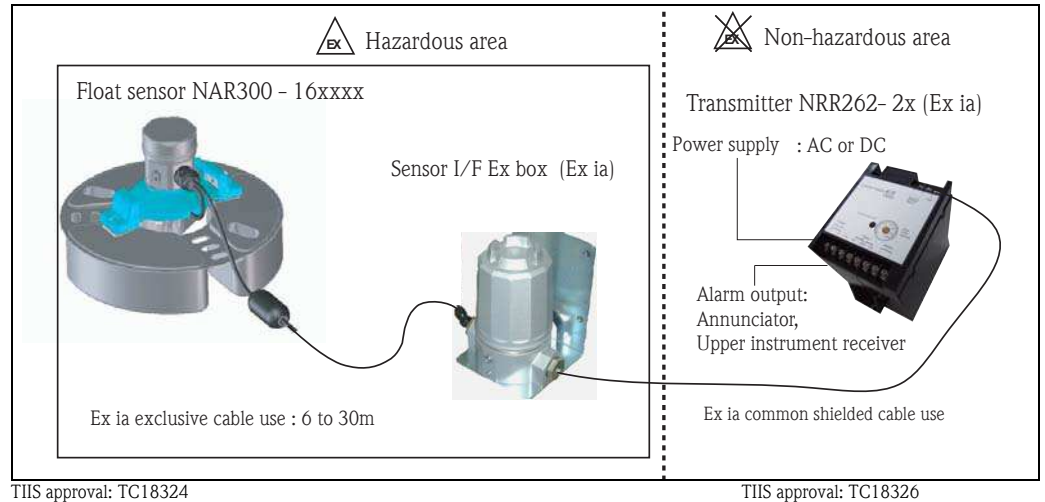

**Ex d[ia]system:  
Ex d[ia]IIB T4**

From oil leak detection to alarm output, the Ex d[ia] oil leak detection system can monitor the entire process outdoor Ex areas. The circuitry is intrinsically safe from the NAR300 float sensor to the input Exd [ia] side of NRR261 Exd [ia] transmitter. The NRR261 output (Ex d) side can be connected to a tank yard junction box or alternatively to level transmitter relay inputs. This configuration allows signal transmission from the float sensor to the transmitter over ranges up to maximum 2.6 Kilometers.

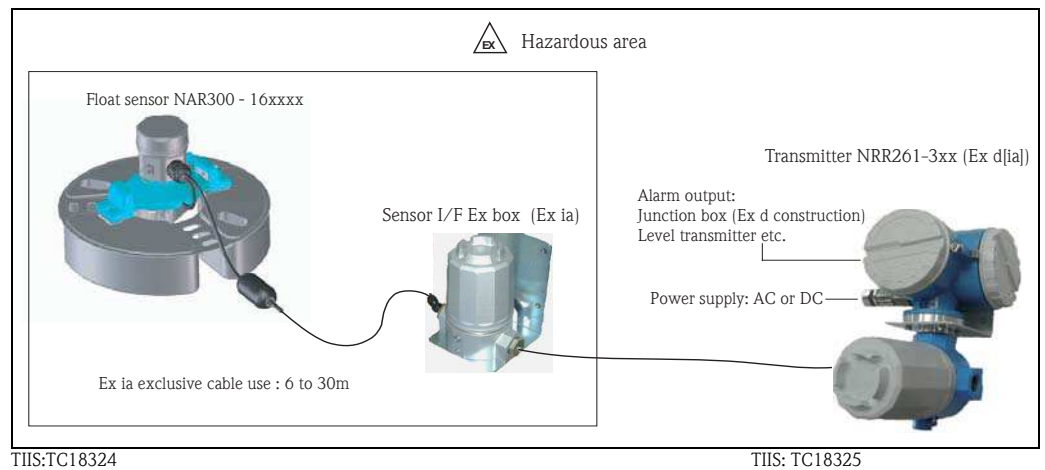

## Operating Principle

### Detection Principle

### Sensing element

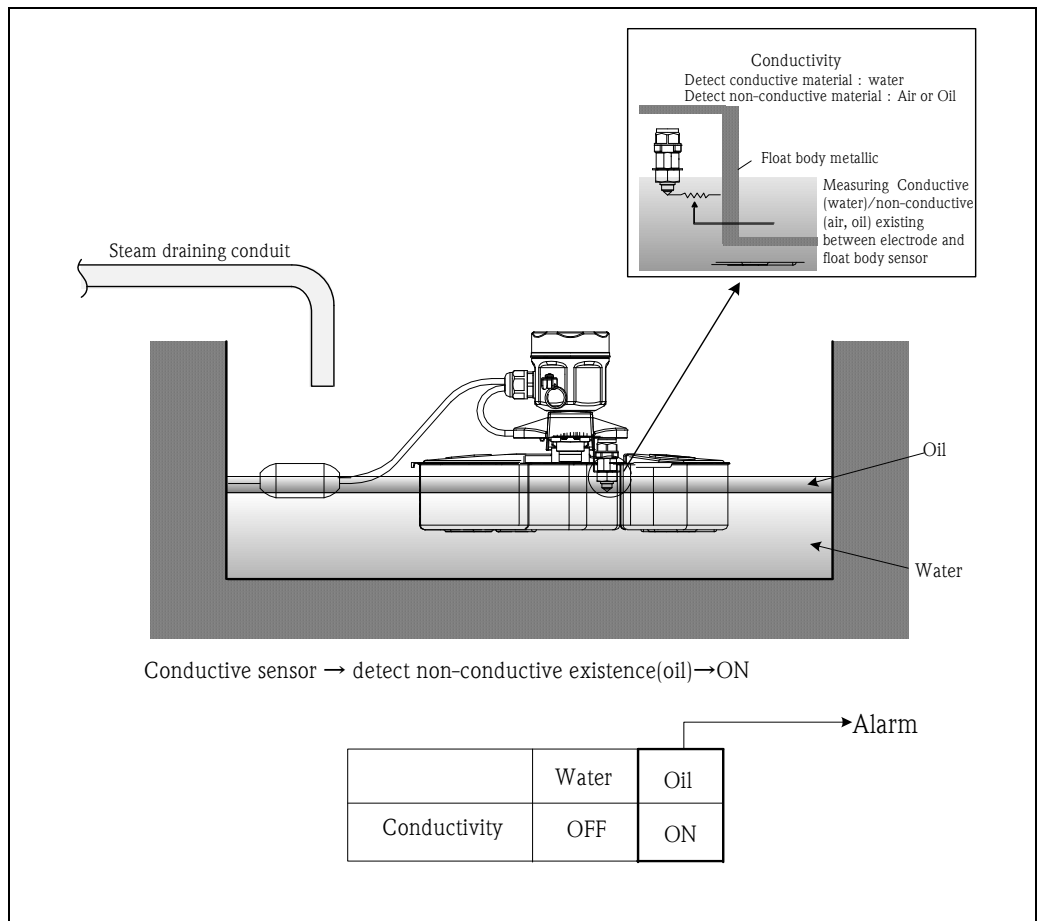
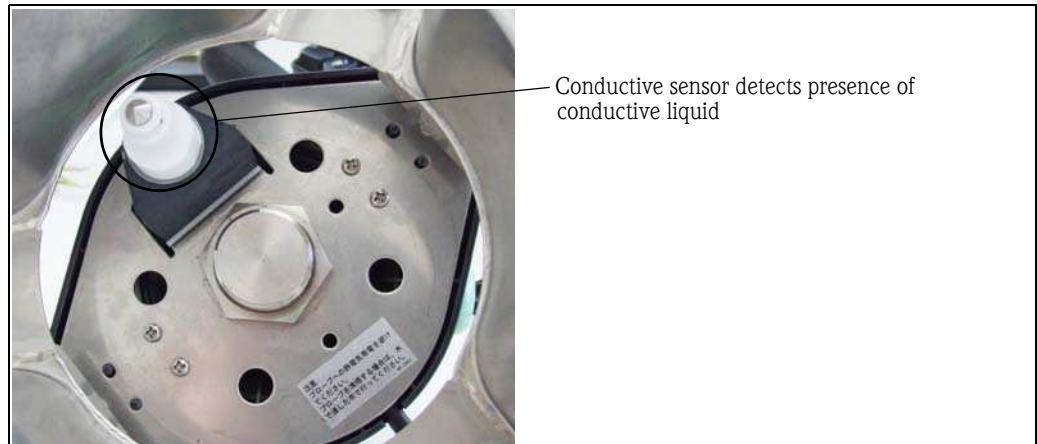

### Detection in water-filled pit

1. Conductive sensor continuously monitors conductivity between probe and float body.
2. When water is detected by the conductive sensor, it is considered the normal condition.
3. When an oil layer forms on the water the conductivity between probe and float body decreases, and conductive probe alarm status turns to ON.

**Alarm principle**

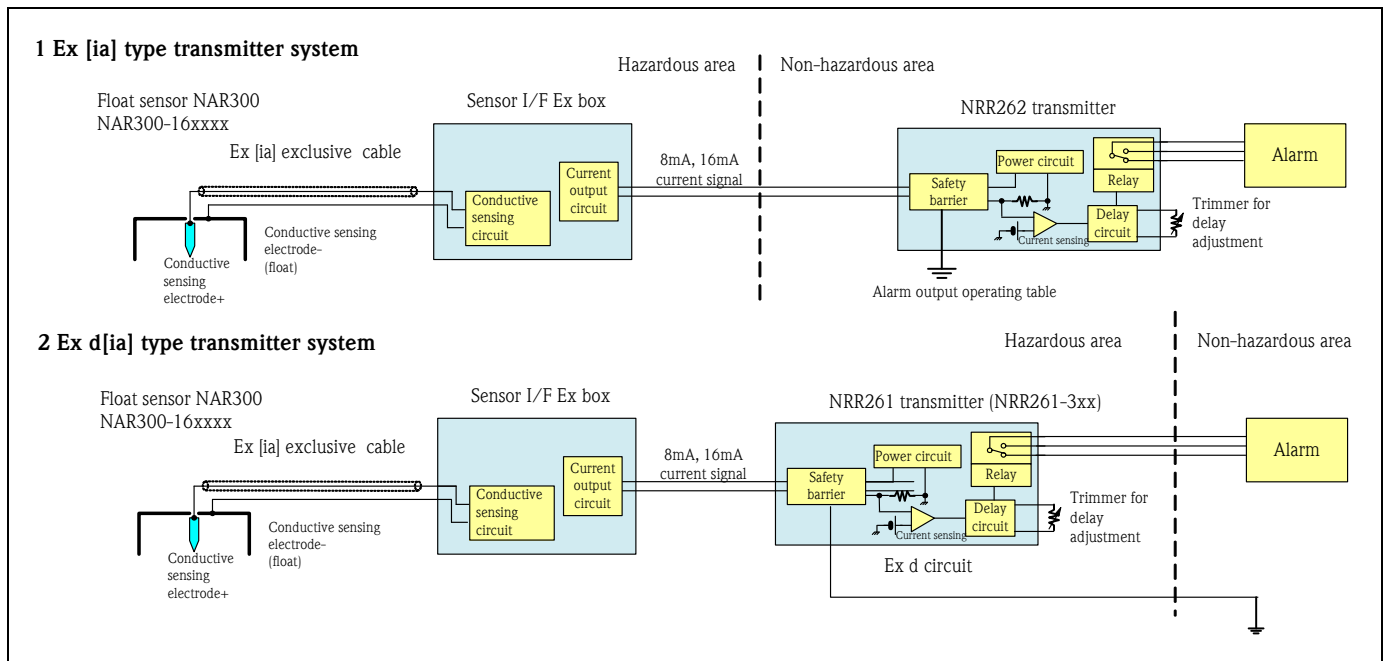

**Principle of Alarm operation**

The oil leak detection signal generated at the float sensor NAR300 is converted to 8mA (alarm OFF) or 16mA (alarm ON) by the current output circuit at the transmitter or Sensor I/F Ex box. It is further connected to the current detection circuit through an IS safety barrier. In the current detection circuit, the existence/absence of oil leak alarm signal is judged according to the current value, sent through a delay circuit and turns the alarm output relay ON or OFF.

The alarm delay circuit is configurable from 1-30 seconds (additional 6 seconds is added as the base delay value). Fail-safe performance of the relay output is also available (see below).

**Alarm output operating table (see page 13-14)**

Condition \ Terminals	NRR262 N.C. to COM	NRR262 N.O. to COM
	NRR261 N.C. to COM terminal :11,13	NRR261 N.O. to COM terminal:13,15
Oil leak alarm	Contact Close	Contact Open
Power OFF	Contact Close	Contact Open
Empty pit	Contact Close	Contact Open
Liquid freezing	Contact Close	Contact Open
Non-alarm	Contact Open	Contact Close

The ON delay time is adjustable via delay trimmer. After turning off power to transmitter NRR261, remove the electronics compartment cover to see the trimmer. On NRR262 the trimmer is located on the surface of the case. It is possible to set the delay from 1-30 seconds. When an alarm condition continues longer than the delay time setting it is judged as an alarm output. If the alarm condition stops within the delay time setting, an alarm is not output, thus preventing false alarms.



**Note!**

A delay time of approx. 6 sec. is automatically added.

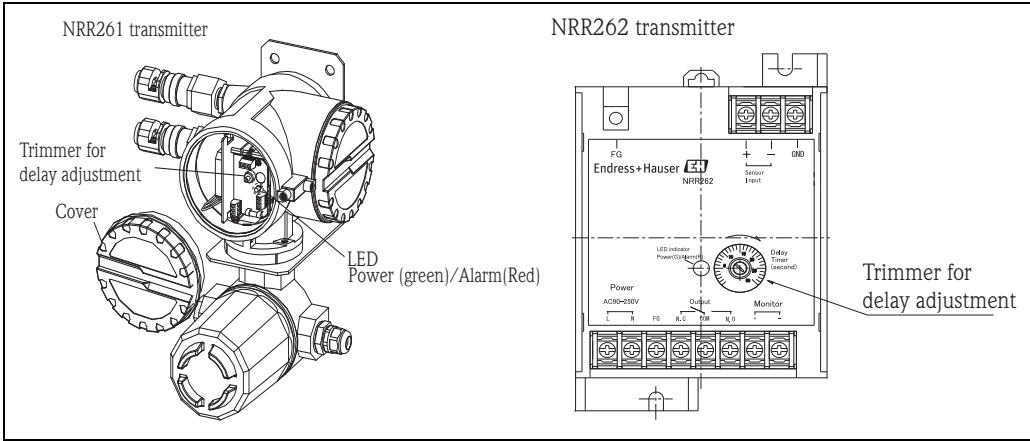

## Operating conditions

---

### Detection Sensitivity

Depending on actual condition, water may sometimes cling to the electrode, even though the sensor is floating on oil above the water. In such case, oil detection sensitivity may be affected by 1 to 2 mm. When absolute precision is required we recommend coating the electrode with a mild detergent in order to keep water from clinging to the electrode.

### Water-filled pits

#### Not for use in salt -water pits

The Float Sensor NAR300 is not designed for use in salt-water. If used in salt-water the following abnormal performance may occur:

- Output an alarm wrongly if overturned by waves
- Salt content may create a short between float sensor and probe, causing alarm delay
- Failure due to salt-water corrosion

#### Pits with liquids other than water

When using the float sensor on particular liquids such as a solvent blend, it may be corroded and damaged.

#### High electrical resistance water in pit

When using the float sensor on high electrical resistance water such as pure water, an alarm may ring. Electric conductivity should be  $\geq 10 \text{ S/cm}$  ( $\leq 100 \mu\text{S/cm}$ ).

As an example:

Pure water is 1 to 0.1S/cm (1 to 10M  $\times\mu\text{S/cm}$ )

#### The water freezing in a pit

When water in the pit freezes, the alarm may ring (fail safe function). Please implement antifreeze prevention measures.

### Gasolin application

For gasolin application, please choose NAR300 with technically special product by contacting your Endress+Hauser representative.

## Installation

### Float sensor NAR300 + Transmitter NRR26x

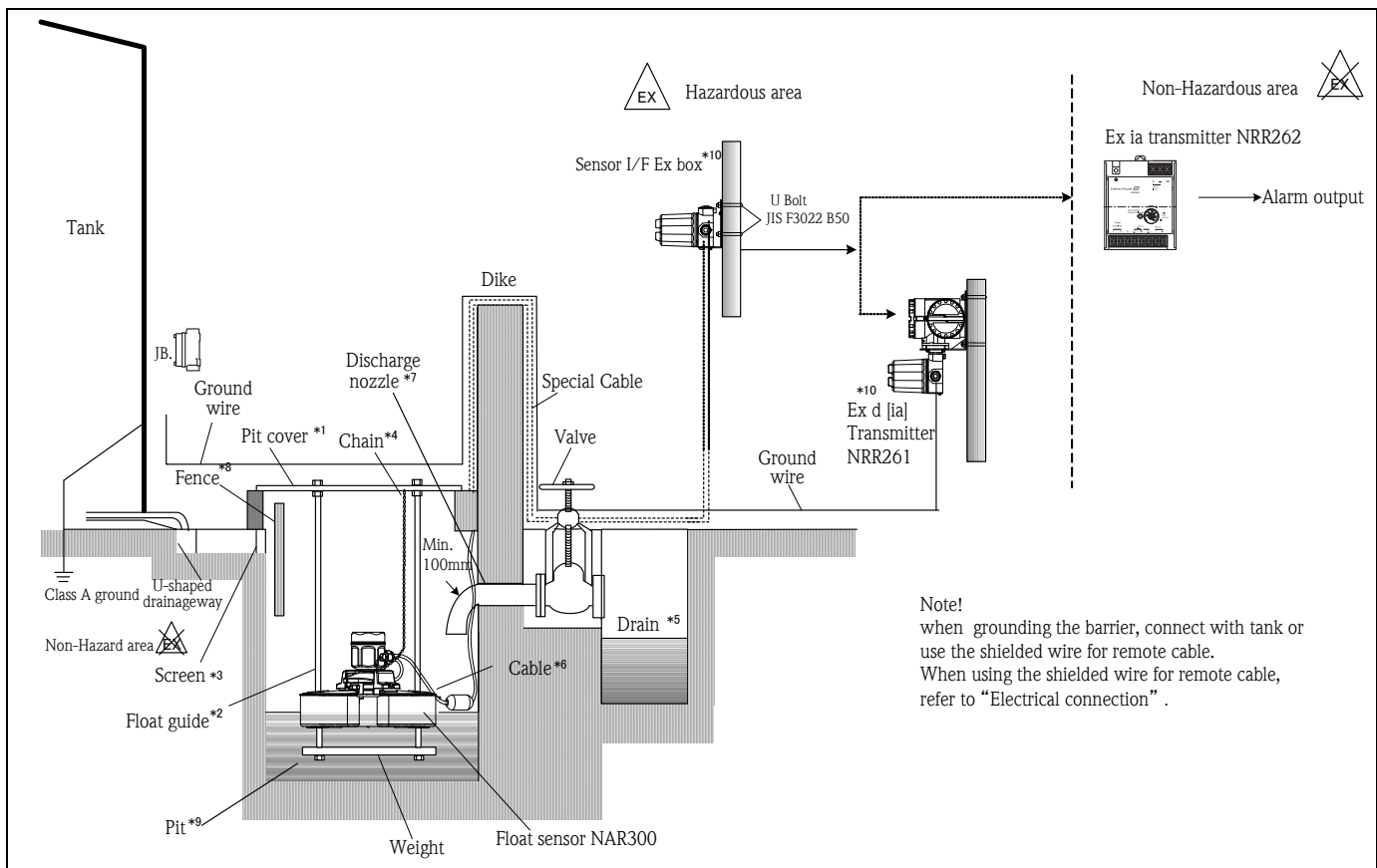

#### Notes regarding installation and mounting



1. Take precautions to prevent rubbish or snow from entering the pit, e.g. rubbish guard, roof, cover etc. If snow accumulates on the float sensor NAR300, it will sink at 1mm per 50g of snow into the water and reduce oil detection sensitivity. Mount covers higher than the top of the pit to avoid submerging the Float Sensor NAR300 during heavy rains. If the float sensor is submerged it may not perform as intended.
2. The Float Sensor NAR300 may not perform as intended if it becomes unbalanced by more than about 3 degrees horizontally. Use float guides as recommended to keep balance, and take care that chains and cables are not tangled in the float or guides.
3. We recommend mounting a screen at the water inlet to prevent rubbish from entering the pit. Conduct periodical inspections/cleaning to maintain optimal performance of the system.
4. It may be convenient to attach a lifting chain to the float sensor head for inspection. Please consider that the sensitivity decreases at 1mm per 50g. Do not use excessive force when pulling the chain.
5. When the pit becomes completely filled with water, even if an oil leak occurs, an oil layer cannot form on the surface of the water due to overflowing from the pit. Please drain water appropriately.
6. Do not pull the sensor by its signal cable. Pulling the signal cable may damage the sensor.
7. When the drain valve is kept continuously open, it should be formed such that it curves downward at least 100mm. Failure to do so may cause any oil to discharge from the pit before it can form a detectable layer on the water surface, resulting in a delayed alarm condition or failure to detect. In the case of a pit without discharge nozzle as illustrated above, install water-fence or other mechanism such that oil will form detectable layer on the water surface.
8. If necessary, set up a fence to prevent extreme waves, crosscurrents, or water splashing onto the float sensor.
9. If the pit is too wide, it may not allow a detectable oil layer to form on the water surface. In this case install a divider to reduce the surface area such that a detectable oil layer will form.
10. Mount the NAR300, NRR261 and I/F Ex box at least 50 cm apart.



## Dimensions

### Float sensor NAR300

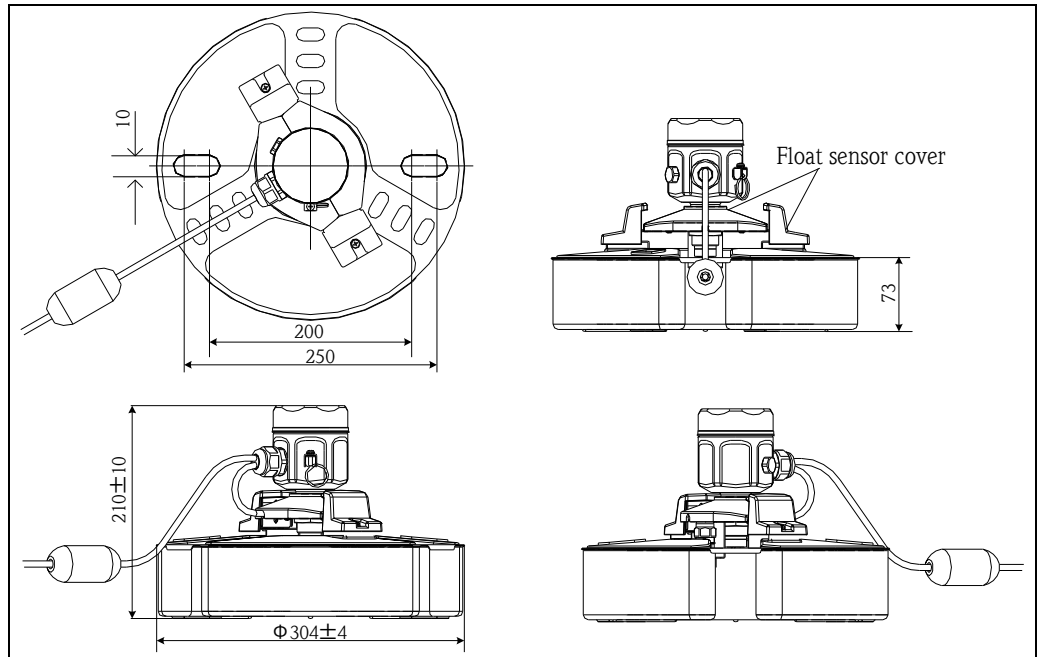

#### Note!

- If the float sensor cover is broken or missing, detection sensitivity may decrease. Replace the broken cover with authorized spare parts from Endress+Hauser.
- If the float sensor NAR300 is used in a pit that contains a liquid/substance that is corrosive to the float sensor material, it should only be used during an actual oil leak. In case of continued use after an oil leak, carry out inspections.
- Take precautions to prevent steam from directly flowing onto the Float Sensor NAR300.
- Do not try to disassemble or adjust the float sensor electrical components. Such actions may cause damage or failure to the sensor.

### Float guide

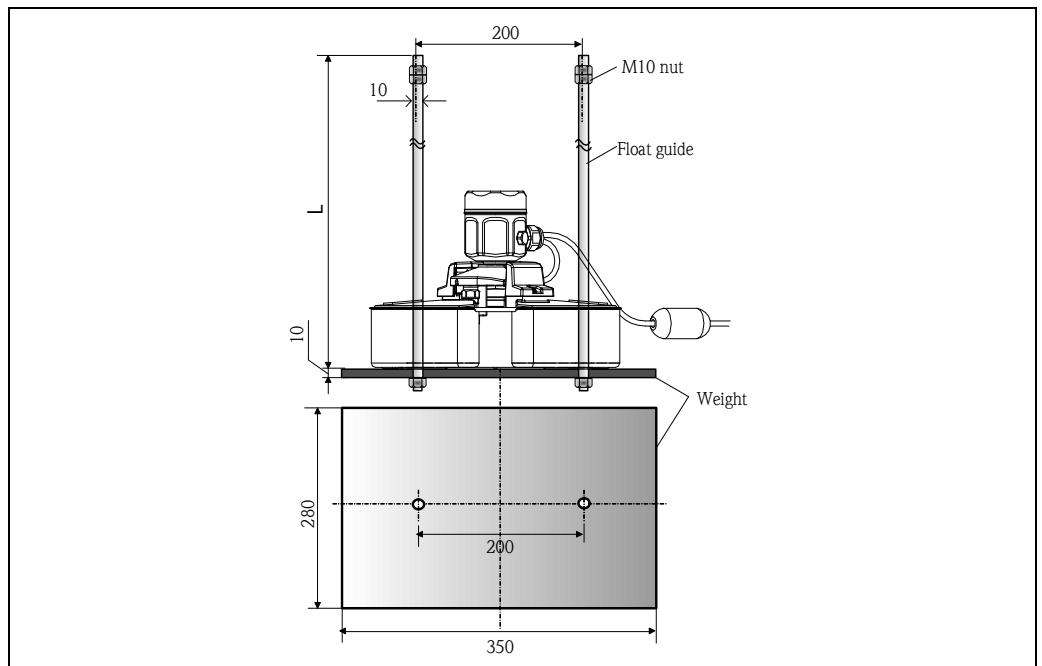

Ex d [ia] Transmitter NRR261

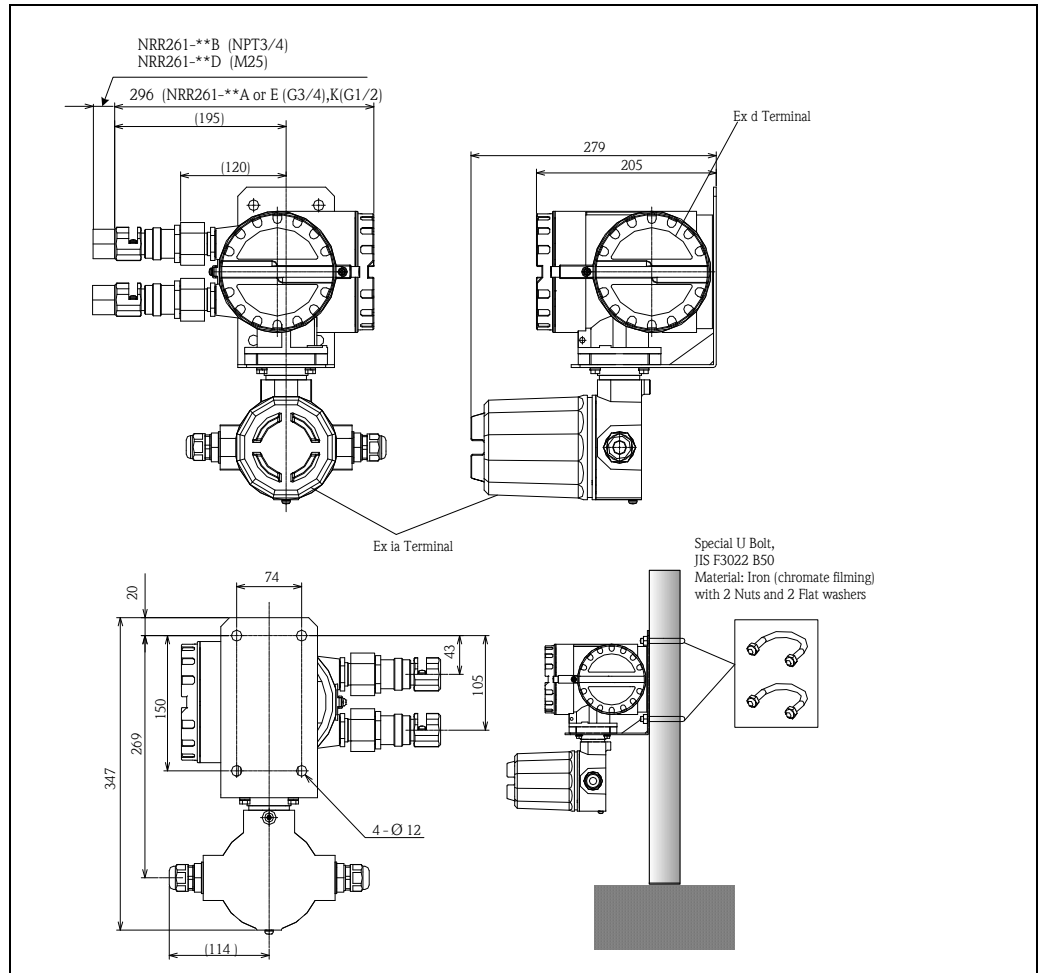

Ex ia Transmitter NRR262

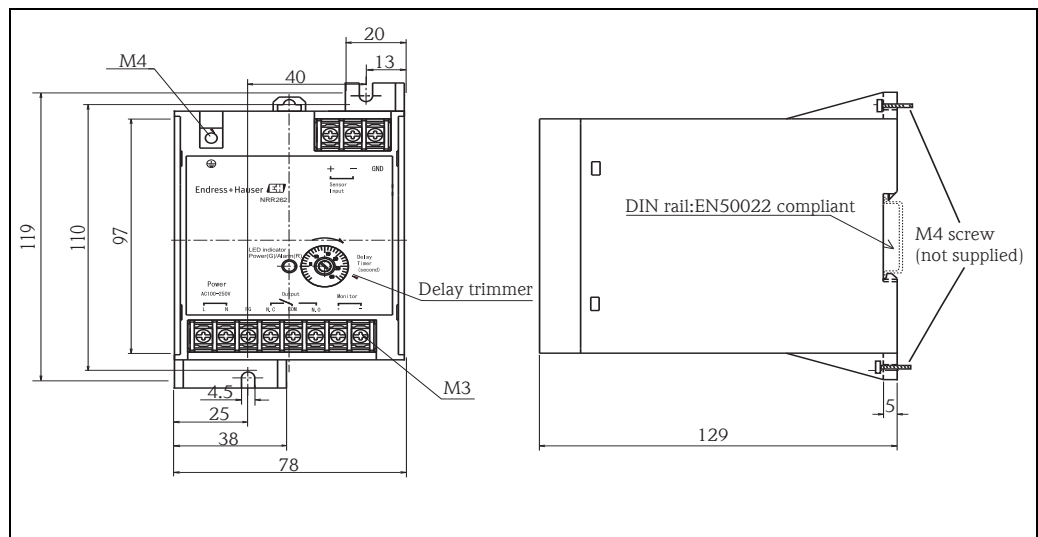

**Ex ia Sensor I/F Ex box**

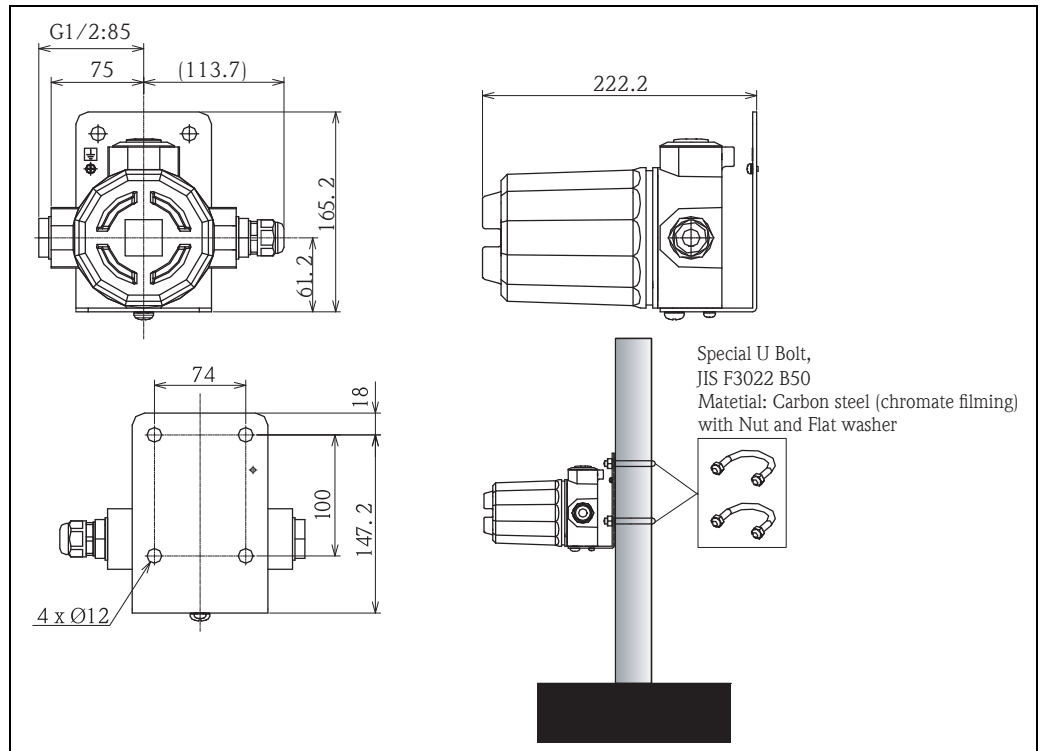

**Note!**

Sensor I/F Ex box is included in the order code of NAR300-16xxxx. This device is used in combination with NRR262-2x (Ex ia) or NRR261-3xx (Ex d [ia]).

## Electrical connection

When using float sensor NAR300 Ex ia together with transmitter NRR261 Ex d[ia], it is necessary to ground the NRR 261 to a safety per barrier the following procedure.



### Note!

The grounding cable for safety barrier should be connected independent of any other devices which do not have safety barriers (e.g. arresters), according to "Class A grounding" standards.

Use a conductive grounding wire with cross-sectional dimensions at least 2 mm<sup>2</sup>.

In an instrumentation room, a field device with Class A ground may be connected in common with the communication cable shield.

### "Class A ground" general description

Ground resistance value	10 Ω
Grounding cable	Tensile strength : more 1.04kN and Metallic wire or copper wire (more 2.6 mm in diameter)

### Grounding cable

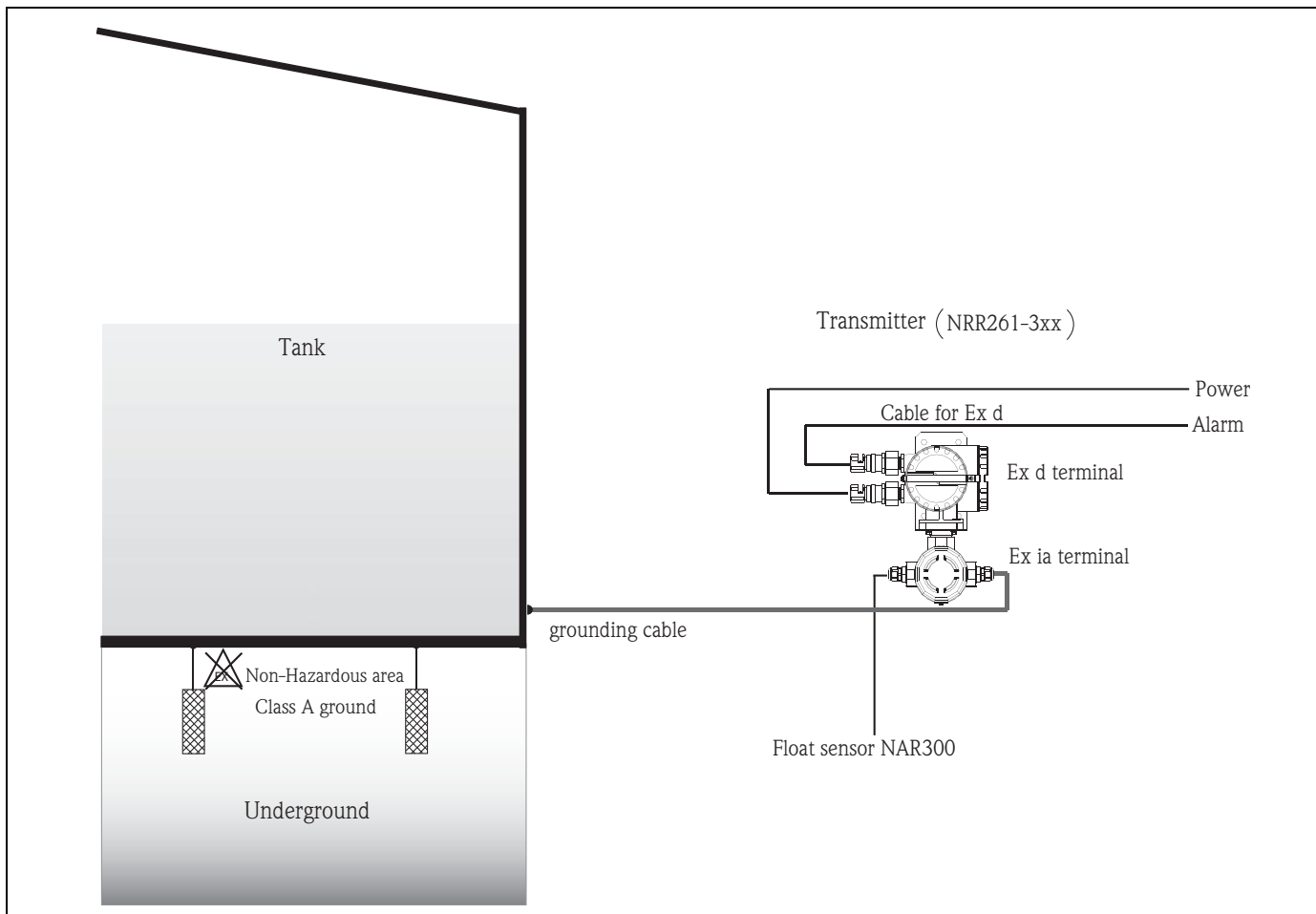

**Ex ia transmitter NRR262-2x**

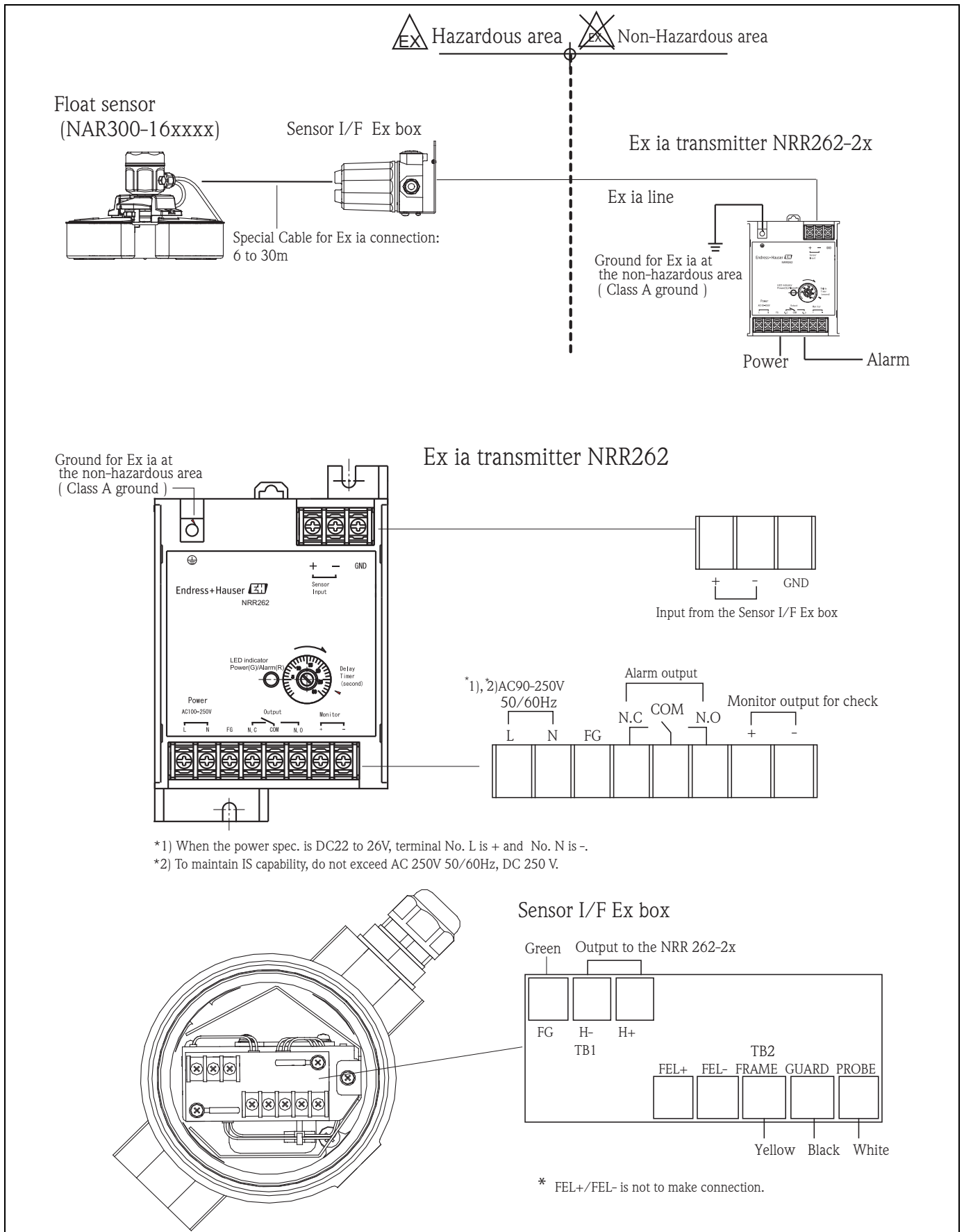

**Ex d[ia] transmitter  
NRR261-3xx**

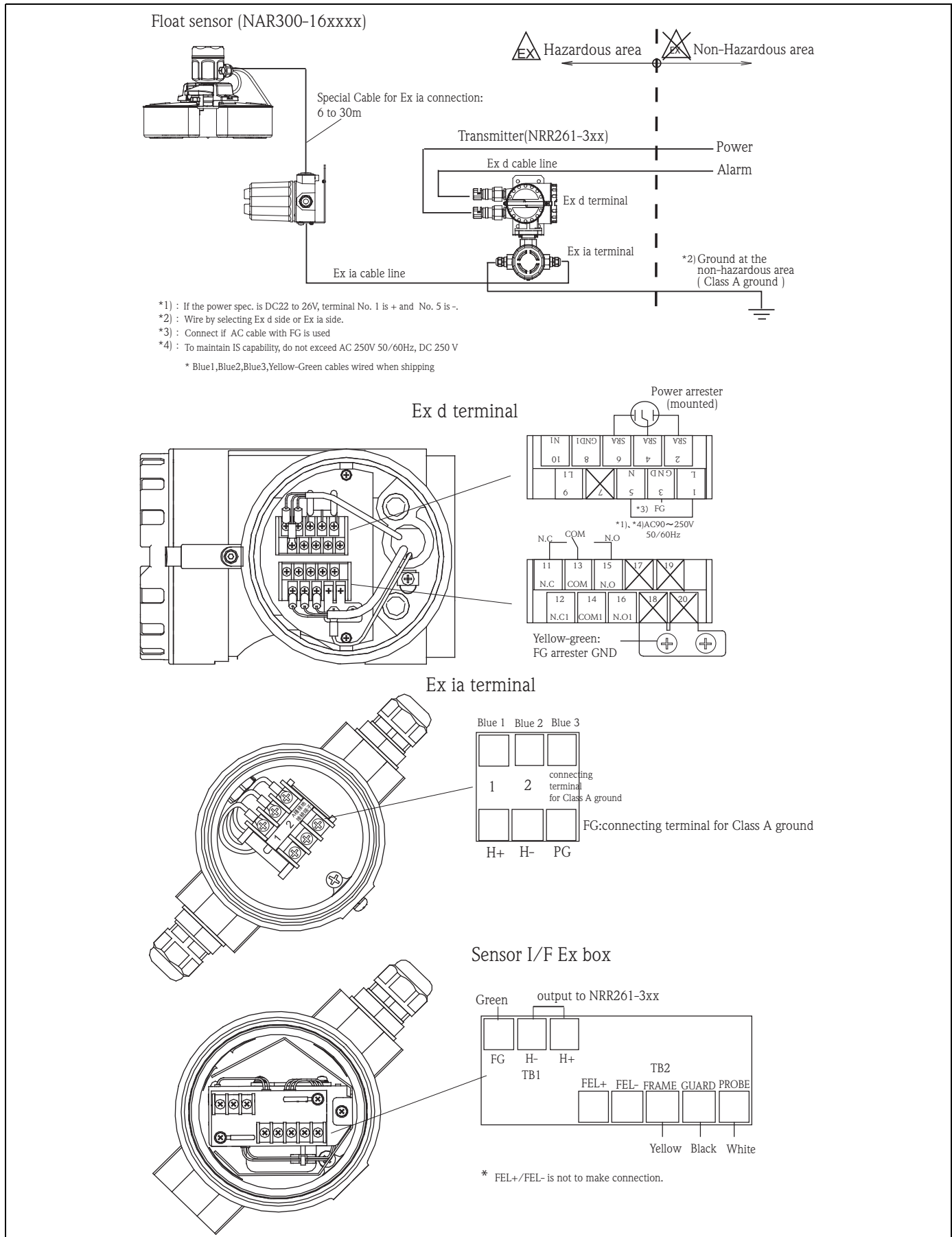

Connection diagram

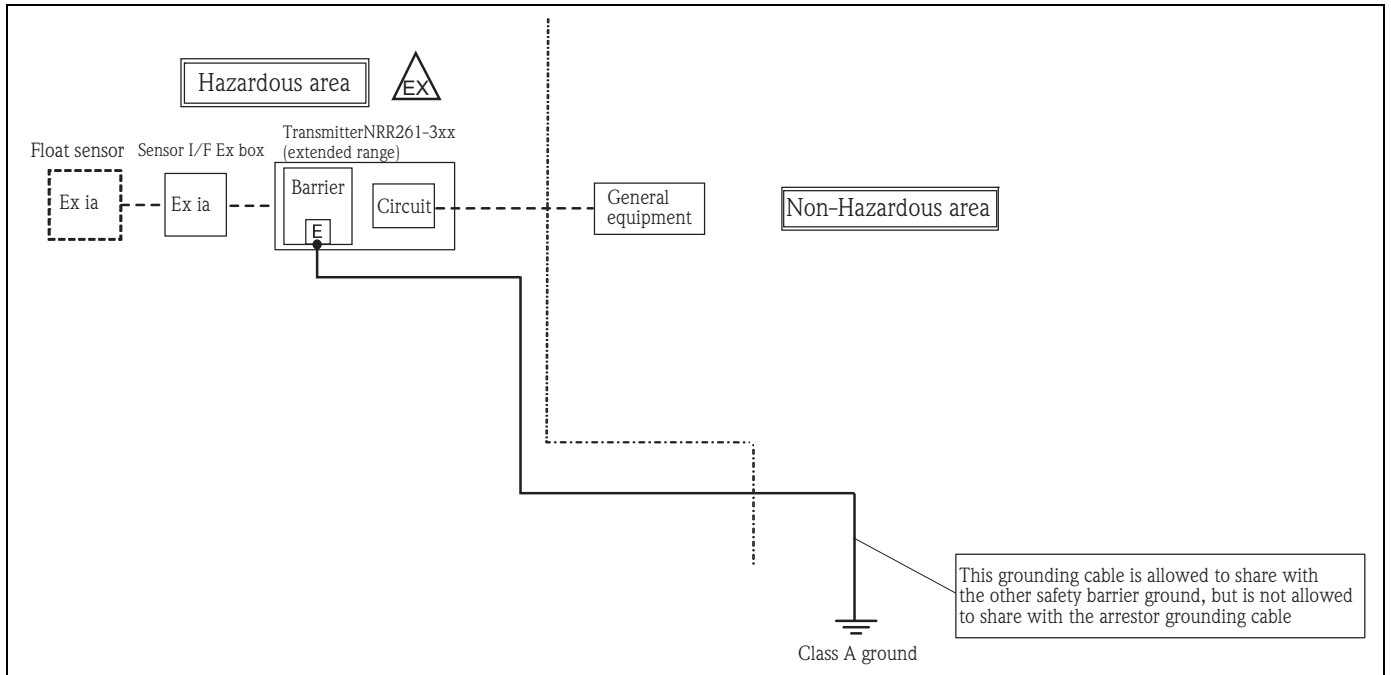

# Ordering Information

**Float Sensor NAR300**

<b>010</b>		<b>Approval:</b>	
	1	Ex ia IIB T4, TIS	
	9	Special version, TSP-no. to be spec.	
<b>020</b>		<b>Type:</b>	
	1	Float	
	2	Float, module set (Econounce NRR261 upgrade)	
	4	Float, Ex box (Econounce NRR262 upgrade)	
	5	Float, Ex box (separate type)	
	6	Float, high temperature, Ex box (separate type)	
	9	Special version, TSP-no. to be spec.	
<b>030</b>		<b>Output:</b>	
	A	2-wire current	
	Y	Special version, TSP-no. to be spec.	
<b>040</b>		<b>Signal Cable:</b>	
	A	6 m	
	B	10 m	
	C	15 m	
	D	20 m	
	E	25 m	
	F	30 m	
	Y	Special version, TSP-no. to be spec.	
<b>050</b>		<b>Float Guide:</b>	
	1	Not used	
	2	Guide 304, weight SS400	
	3	Guide 304, weight 304	
	9	Special version, TSP-no. to be spec.	
<b>060</b>		<b>Cable Entry:</b>	
	A	Not needed	
	B	G1/2	
	C	NPT 1/2	
	E	M25	
	Y	Special version, TSP-no. to be spec.	
<b>NAR300-</b>			

Complete product designation



**Transmitter NRR261**

<b>010</b>	<b>Approval:</b>			
	2	Ex d[ia] IIB T4, TIIS (NAR300)		
	3	TIIS, Ex d[ia] IIB T4 (NAR300 separate type)		
	9	Special version, TSP-no. to be spec.		
<b>020</b>	<b>Power Supply:</b>			
	A	90-250VAC 50/60Hz		
	B	22-26VDC		
	Y	Special version, TSP-no. to be spec.		
<b>030</b>	<b>Cable Entry:</b>			
	A	G 3/4 x 2 (Ex d)		
	B	NPT3/4 x 2 (Ex d)		
	D	M25 x 2 (Ex d)		
	E	G3/4 x 2 (Ex d), G1/2 x 1 (Ex ia)		
	K	G1/2 x 2 (Ex d), G1/2 x 1 (Ex ia)		
	Y	Special version, TSP-no. to be spec.		
<b>NRR261-</b>				Complete product designation

**Transmitter NRR262**

<b>010</b>	<b>Approval:</b>			
	2	Ex ia IIB T4, TIIS (NAR 300)		
	9	Special version, TSP-no. to be spec.		
<b>020</b>	<b>Power Supply:</b>			
	A	90-250VAC 50/60Hz		
	B	22-26VDC		
	Y	Special version, TSP-no. to be spec.		
<b>NRR262-</b>				Complete product designation

## Specifications

### Float sensor NAR300

Protection class	IP67 (for outdoor installation)
Power Supply	by transmitter
Wetted material	Float : SUS316L Conductive sensor: SUS316, PTFE
Detection sensitivity*1	Water-filled pit: 10 +/- 1mm, alarm setting before delivery with kerosene
I/O cable	Exclusive FKM shield cable, including cable float (6m standard)
Weight	Approx. 2.5kg (including 6m (FKM) cable).

\*1: Kerosene (relative density approx. 0.8 g/cm<sup>3</sup>), on water (relative density approx. 1.0 g/cm<sup>3</sup>), static level condition, no surface tension

### Sensor I/F Ex box

Protection class	IP67 (for outside installation )
Power Supply	by NRR261 or NRR262(with an arrester)
output signal	Approx. 7 to 16mA
Cable entry	NAR300 (Float sensor): G1/2 with a cable gland x1 NRR261 or NRR262 (Transmitter): G1/2 thread x1
Weight	Approx. 3.2kg

### Transmitter NRR261

Protection class	IP67 (for outside installation )
Power Supply	90 to 250VAC, 50/60Hz 22 to 26VDC (with an arrester)
Power consumption	20VA/2W
Input	Approx. 7 to 16mA from NAR300 / Sensor I/F Ex box
Output	Contact output :1SPDT contact rate : 250VAC, 1A, 100VA, 100VDC : 1A, 25W  Delay setting: 1 to 30 sec. by the delay trimmer (add 6 sec. as base delay) Failsafe function: available if power fail, frozen sensor (see alarm output table on page 5)
Cable entry	Ex d side: G 3/4 x 2, TIIS Ex specified cable glands model SXBM Exi side: G 1/2 x 1, with cable gland
Arrester	Built-into power supply
Weight	Approx. 10 kg

**Transmitter NRR262**

Protection class	IP20 (for inside installation )
Power Supply	90 to 250VAC, 50/60Hz 22 to 26VDC
Power consumption	20VA/2W
Input	Approx. 7 to 16mA from NAR300 / Sensor I/F Ex box
Output	Contact output :1SPDT contact rate : 250VAC, 1A, 100VA, 100VDC, 1A, 25W Delay setting: 1 to 30 seconds by the delay trimmer (add 6 seconds as base delay) Failsafe function: available if power fail, frozen sensor (see "alarm output table" on page 5)
Arrester	Built-into power supply
Weight	Approx. 0.6 kg

## Process Conditions

### Float sensor NAR300

Detective object	Relative density greater than 0.7 g/cm <sup>3</sup> and less than 1.0 g/cm <sup>3</sup> . When relative density is greater than 0.9 g/cm <sup>3</sup> , dynamic viscosity must be greater than 1mPa·s. Water is approximately 1 mPa·s.  Not soluble in water  Non-conductivity  Flowing
Operating temperature	Ambient : -20 to +100 °C (- 4 to +212 °F) Measuring liquid : 0 to +100 °C (+32 to +212 °F)
Water in pit	Relative density greater than 1.0 g/cm <sup>3</sup> and less than 1.13 g/cm <sup>3</sup> . (when kinematic viscosity equals 1mm <sup>2</sup> /sec) * <sup>2</sup>  Not frozen  Conductivity is greater than 10 μS/cm and less than 100k Ω·cm. (greater than 1 μS/cm if float sensor is normally floating on the water).  Not salt-water
Other	Clean off any debris that sticks to the sensor.  Do not let mud cake on the float sensor.  Avoid pit conditions that cause the float sensor to tilt off-balance or change the draft-line.  Install measures to avoid cross-currents, standing waves.

\*<sup>2</sup> pre-delivery setting is done with kerosene on water; therefore sensitivity may differ if the lower liquid is diluted with e.g. antifreeze.

### Sensor I/F Ex box

Connecting cable	Maximum inductance 3mH, maximum capacitance 83nF e.g. KPEV (instrumentation cable) C=65nF/km, L=0.65mH/km CW/C=0.083μF/65nF=1.276km [1] LW/L=3mH/0.65mH=4.615km [2] Maximum cable length = 1.27km * The smaller of [1] or [2] is the maximum usable cable length. (Fractions are truncated)
Operating temperature	Ambient : -20 to +60 °C (- 4 to +140 °F)

### Transmitter NRR261

Connecting cable	Maximum inductance 3mH, maximum capacitance 83nF e.g. KPEV (instrumentation cable) C=65nF/km, L=0.65mH/km CW/C=0.083μF/65nF=1.276km [1] LW/L=3mH/0.65mH=4.615km [2] Maximum cable length = 1.27km * The smaller of [1] or [2] is the maximum usable cable length. (Fractions are truncated)
Operating temperature	Ambient : -20 to +60 °C (- 4 to +140 °F)

**Transmitter NRR262**

Connecting cable	Maximum inductance 3mH, maximum capacitance 83nF e.g. KPEV (instrumentation cable) $C=65\text{nF/km}$ , $L=0.65\text{mH/km}$ $CW/C=0.083\mu\text{F}/65\text{nF}=1.276\text{km}$ [1] $LW/L=3\text{mH}/0.65\text{mH}=4.615\text{km}$ [2] Maximum cable length = 1.27km * The smaller of [1] or [2] is the maximum usable cable length. (Fractions are truncated)
Operating temperature	Ambient : -20 to +60 °C (- 4 to +140 °F)

## Accessory

### Float guide

#### Note!

When mounting the float guide weight, set it up horizontally. Remove trash and stones on the pit bottom before mounting the Float Sensor. The length of float guide is 2m (standard), but if you need anything else, please order as special version.

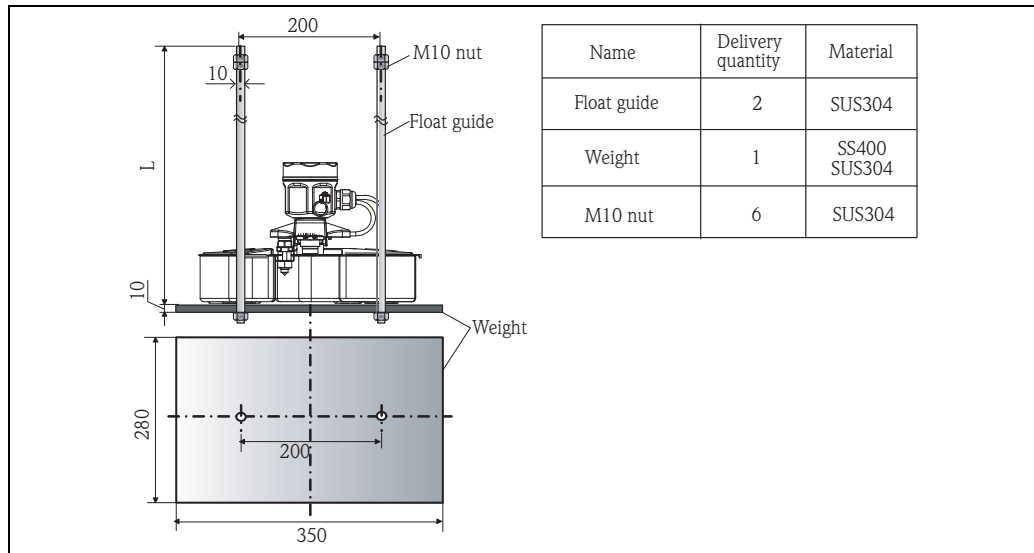

### U bolt and cable gland

U bolt (JIS F3022 B50) is used for mounting the transmitter. Please prepare a pipe of nominal 50A (2B Ø60.5 mm). Tighten and fix the cable gland after insert a cable from the float sensor NAR 300.

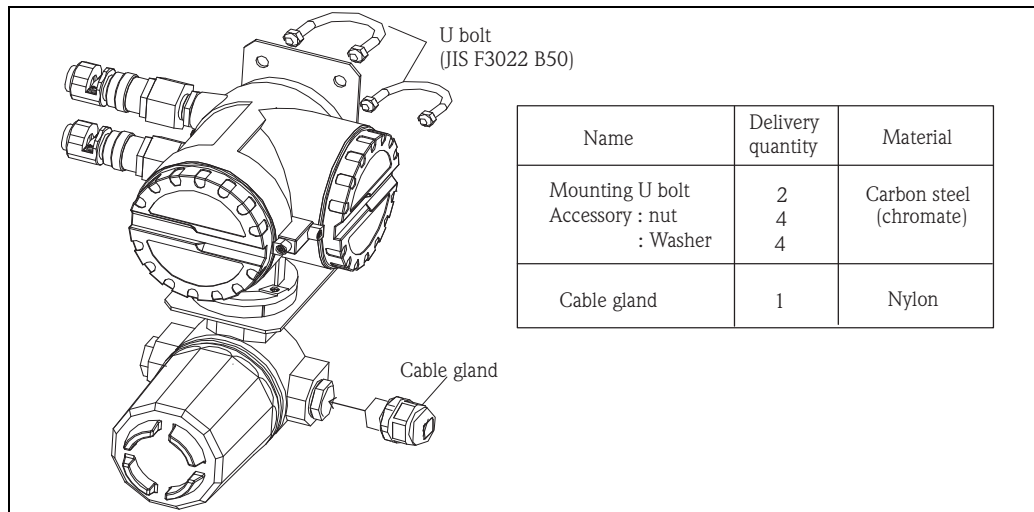

## Certificates and approvals

---

**Ex approval**

**TIIS**

Ex ia IIB T4 (Float sensor NAR300-16xxxx high temperature separate type)  
Ex d [ia] IIB T4 (Transmitter NRR261-3xx separate type)  
Ex ia IIB T4 (NRR262-2x separate type)

## Documentation

---

**Operating Instructions**

**BA00403G**

Oil Leak Detector NAR300 System High Temperature

---

**Safety Instructions**

**XA00587G-A**

TC18324 (NAR300)

**XA00588G-A**

TC18325 (Transmitter)

**XA00589G-A**

TC18326 (Transmitter)

Endress + Hauser Yamanashi Co., Ltd.  
862-1 Mitsukunugi Sakaigawa-cho  
Fuefuki-shi Yamanashi,  
406-0846 Japan

Phone: ++81 55 266 4964  
Fax: ++81 55 266 4969  
<http://www.endress.com>