



Level



Pressure



Flow



Temperature

Liquid
Analysis

Registration

Systems
Components

Services



Solutions

Technical Information

Omnigrad S TR62, TC62

Modular thermometer

TR62 with resistance insert (RTD)

TC62 with thermocouple insert (TC)

Explosion-protected, for screwing into a thermowell



Application

- Heavy duty applications
- Oil & Gas processing industry
- Measuring range:
 - Resistance insert (RTD):
–200 to 600 °C (–328 to 1 115 °F)
 - Thermocouple (TC):
–40 to 1 100 °C (–40 to 2 012 °F)
- Protection class: IP66/68

Head transmitter

All Endress+Hauser transmitters are available with enhanced accuracy and reliability compared to directly wired sensors. Easy customizing by choosing one of the following outputs and communication protocols:

- Analog output 4 to 20 mA
- HART®
- PROFIBUS® PA
- FOUNDATION Fieldbus™

Your benefits

- High degree of flexibility thanks to modular design with standard terminal heads as per DIN EN 50446 and customer-specific immersion lengths
- High degree of insert compatibility and design as per DIN 43772
- Extension neck, nipple union version, to protect the head transmitter from overheating
- Types of protection for use in hazardous locations
 - Intrinsic Safety (Ex ia)
 - Flameproof (Ex d)
 - Non-sparking (Ex nA)

Function and system design

Measuring principle

Resistance thermometer (RTD)

These resistance thermometers use a Pt100 temperature sensor according to IEC 60751. The temperature sensor is a temperature-sensitive platinum resistor with a resistance of 100 Ω at 0 °C (32 °F) and a temperature coefficient $\alpha = 0.003851 \text{ } ^\circ\text{C}^{-1}$.

There are generally two different kinds of platinum resistance thermometers:

- **Wire wound (WW):** Here, a double coil of fine, high-purity platinum wire is located in a ceramic support. This is then sealed top and bottom with a ceramic protective layer. Such resistance thermometers not only facilitate very reproducible measurements but also offer good long-term stability of the resistance/temperature characteristic within temperature ranges up to 600 °C (1 112 °F). This type of sensor is relatively large in size and it is comparatively sensitive to vibrations.
- **Thin film platinum resistance thermometers (TF):** A very thin, ultrapure platinum layer, approx. 1 μm thick, is vaporized in a vacuum on a ceramic substrate and then structured photolithographically. The platinum conductor paths formed in this way create the measuring resistance. Additional covering and passivation layers are applied and reliably protect the thin platinum layer from contamination and oxidation, even at high temperatures.

The primary advantages of thin film temperature sensors over wire wound versions are their smaller sizes and better vibration resistance. A relatively low principle-based deviation of the resistance/temperature characteristic from the standard characteristic of IEC 60751 can frequently be observed among TF sensors at high temperatures. As a result, the tight limit values of tolerance category A as per IEC 60751 can only be observed with TF sensors at temperatures up to approx. 300 °C (572 °F). For this reason, thin-film sensors are generally only used for temperature measurements in ranges below 400 °C (932 °F).

Thermocouples (TC)

Thermocouples are comparatively simple, robust temperature sensors which use the Seebeck effect for temperature measurement: if two electrical conductors made of different materials are connected at a point, a weak electrical voltage can be measured between the two open conductor ends if the conductors are subjected to a thermal gradient. This voltage is called thermoelectric voltage or electromotive force (emf.). Its magnitude depends on the type of conducting materials and the temperature difference between the "measuring point" (the junction of the two conductors) and the "cold junction" (the open conductor ends). Accordingly, thermocouples primarily only measure differences in temperature. The absolute temperature at the measuring point can be determined from these if the associated temperature at the cold junction is known or is measured separately and compensated for. The material combinations and associated thermoelectric voltage/temperature characteristics of the most common types of thermocouple are standardized in the IEC 60584 and ASTM E230/ANSI MC96.1 standards.

Measuring system

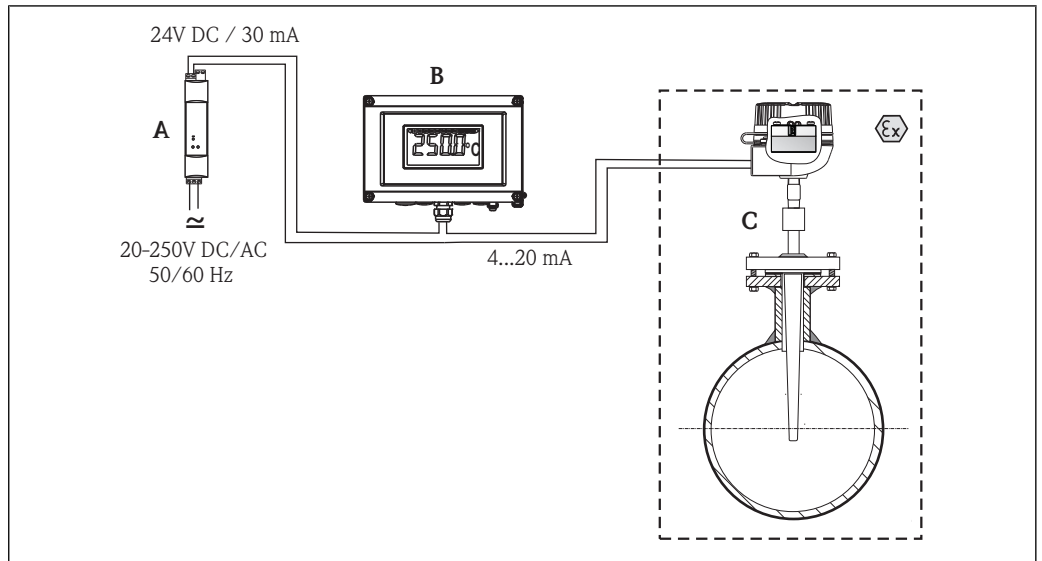

A0016336

1 Application example

- A Active barrier RN221N - The RN221N (24 V DC, 30 mA) active barrier has a galvanically isolated output for supplying voltage to loop-powered transmitters. The universal power supply works with an input supply voltage of 20 to 250 V DC/AC, 50/60 Hz, which means that it can be used in all international power grids. More information on this can be found in the Technical Information (see "Documentation").
- B RIA16 field display unit - The display unit records the analog measuring signal from the head transmitter and shows this on the display. The LC display shows the current measured value in digital form and as a bar graph indicating a limit value violation. The display unit is looped into the 4 to 20 mA circuit and gets the required energy from there. More information on this can be found in the Technical Information (see "Documentation").
- C Mounted thermometer with head transmitter installed.

Design

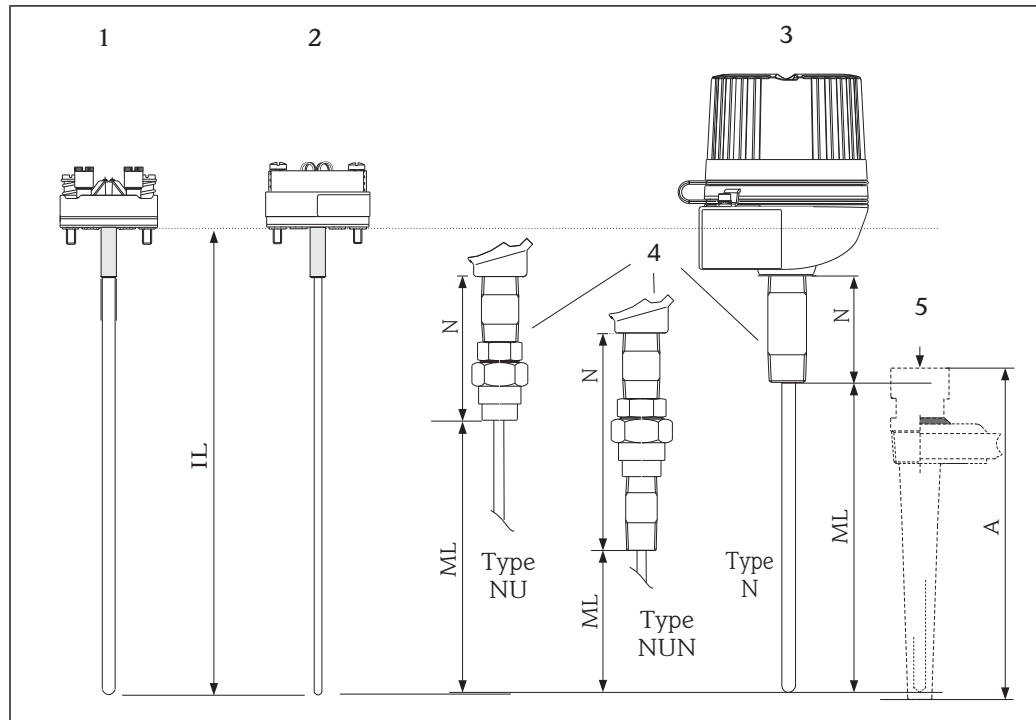

A0016439-EN

 2 Thermometer design

- 1 Insert with mounted ceramic connection socket (example)
 2 Insert with mounted head transmitter (example)
 3 Terminal head
 4 Thermowell connection
 5 Existing onsite thermowell located in the process
 IL Total length of insert
 ML Insertion length
 N Extension neck length
 A Thermowell length

Thermometers from the Omnigrad S TR62 and TC62 series have a modular design. The terminal head is used as a connection module for the mechanical and electrical connection of the insert. The position of the actual thermometer sensor in the insert ensures that it is mechanically protected. If the insert is installed in a thermowell, it can be replaced or calibrated without interrupting the process. The insert has flying leads, a ceramic connection socket or mounted temperature transmitter. The thermometers are designed for installation in an existing onsite thermowell. Different threaded connections are available on the bottom of the extension neck for installation in the thermowell.

Measuring range

- RTD: -200 to 600 °C (-328 to 1112 °F)
- TC: -40 to 1100 °C (-40 to 2012 °F)

Performance characteristics

Operating conditions

Ambient temperature

Terminal head	Temperature in °C (°F)
Without mounted head transmitter	Depends on the terminal head used and the cable gland or fieldbus connector, see 'Terminal heads' section (→  9)
With mounted head transmitter	-40 to 85 °C (-40 to 185 °F)
With mounted head transmitter and display	-20 to 70 °C (-4 to 158 °F)

Process pressure

The maximum process pressure depends on the thermowell into which the thermometer is screwed. For an overview of the Endress+Hauser thermowells which may be used, see (→ 17).

Permitted flow rate as a function of immersion length

The maximum permitted flow rate to which the thermometer can be subjected, reduces the greater the immersion depth of the thermowell in the flowing medium. In addition, it is dependent on the diameter of the tip of the thermowell, the medium type, process temperature and process pressure. For an overview of the Endress+Hauser thermowells which may be used, see (→ 17).

Shock and vibration resistance

- RTD: 3G / 10 to 500 Hz as per IEC 60751
- TC: 4G / 2 to 150 Hz as per IEC 60068-2-6

Accuracy

RTD resistance thermometer as per IEC 60751

Class	Max. tolerances (°C)	Temperature range	Characteristics
RTD max. error type TF - range: -50 to +500 °C			
Cl. AA, former 1/3 Cl. B	$\pm (0.1 + 0.0017 \cdot t ^{1.1})$	0 to +150 °C	
Cl. A	$\pm (0.15 + 0.002 \cdot t ^{1.1})$	-30 to +300 °C	
Cl. B	$\pm (0.3 + 0.005 \cdot t ^{1.1})$	-50 to +500 °C	
RTD maximum error type WW - range: -196 to +600 °C			
Cl. AA, former 1/3 Cl. B	$\pm (0.1 + 0.0017 \cdot t ^{1.1})$	-50 to +250 °C	
Cl. A	$\pm (0.15 + 0.002 \cdot t ^{1.1})$	-100 to +450 °C	
Cl. B	$\pm (0.3 + 0.005 \cdot t ^{1.1})$	-196 to +600 °C	

1) |t| = absolute value °C

In order to obtain the maximum tolerances in °F, the results in °C must be multiplied by a factor of 1.8.

Permissible deviation limits of thermoelectric voltages from the standard characteristic for thermocouples as per IEC 60584 or ASTM E230/ANSI MC96.1:

Standard	Type	Standard tolerance		Special tolerance	
		Class	Deviation	Class	Deviation
IEC 60584	J (Fe-CuNi)	2	$\pm 2.5 \text{ }^\circ\text{C}$ (–40 to 333 $^\circ\text{C}$) $\pm 0.0075 \text{ } t ^{1)}$ (333 to 750 $^\circ\text{C}$)	1	$\pm 1.5 \text{ }^\circ\text{C}$ (–40 to 375 $^\circ\text{C}$) $\pm 0.004 \text{ } t ^{1)}$ (375 to 750 $^\circ\text{C}$)
	K (NiCr-NiAl)	2	$\pm 2.5 \text{ }^\circ\text{C}$ (–40 to 333 $^\circ\text{C}$) $\pm 0.0075 \text{ } t ^{1)}$ (333 to 1 200 $^\circ\text{C}$)	1	$\pm 1.5 \text{ }^\circ\text{C}$ (–40 to 375 $^\circ\text{C}$) $\pm 0.004 \text{ } t ^{1)}$ (375 to 1 000 $^\circ\text{C}$)

1) $|t|$ = absolute value $^\circ\text{C}$

Standard	Type	Standard tolerance	Special tolerance
ASTM E230/ANSI MC96.1		Deviation, the larger respective value applies	
	J (Fe-CuNi)	$\pm 2.2 \text{ K}$ or $\pm 0.0075 \text{ } t ^{1)}$ (0 to 760 $^\circ\text{C}$)	$\pm 1.1 \text{ K}$ or $\pm 0.004 \text{ } t ^{1)}$ (0 to 760 $^\circ\text{C}$)
	K (NiCr-NiAl)	$\pm 2.2 \text{ K}$ or $\pm 0.02 \text{ } t ^{1)}$ (–200 to 0 $^\circ\text{C}$) $\pm 2.2 \text{ K}$ or $\pm 0.0075 \text{ } t ^{1)}$ (0 to 1 260 $^\circ\text{C}$)	$\pm 1.1 \text{ K}$ or $\pm 0.004 \text{ } t ^{1)}$ (0 to 1 260 $^\circ\text{C}$)

1) $|t|$ = absolute value $^\circ\text{C}$

Response time

Calculated at an ambient temperature of approx. 23 $^\circ\text{C}$ by immersing in running water (0.4 m/s flow rate, 10 K excess temperature):

Thermometer type	Shaft diameter of insert	$t_{(x)}$	Response time
Resistance thermometer (measuring probe Pt100, TF/WW)	6 mm (0.24 in)	t_{50}	3.5 s
		t_{90}	8.0 s
	3 mm (0.12 in)	t_{50}	2.0 s
		t_{90}	5.0 s
Thermocouple	6 mm (0.24 in)	t_{50}	2.5 s
		t_{90}	6.0 s
	3 mm (0.12 in)	t_{50}	1 s
		t_{90}	3 s



Response time for insert without transmitter.

Insulation resistance

Insulation resistance $\geq 100 \text{ M}\Omega$ at ambient temperature.

Insulation resistance between the terminals and the extension neck is measured with a voltage of 100 V DC.

Self heating

RTD elements are passive resistances that are measured using an external current. This measurement current causes a self-heating effect in the RTD element itself which in turn creates an additional measurement error. In addition to the measurement current, the size of the measurement error is also affected by the temperature conductivity and flow velocity of the process. This self-heating error is negligible when an Endress+Hauser iTEMP[®] temperature transmitter (very small measurement current) is connected.

Calibration

Endress+Hauser provides comparison temperature calibration from –80 to +1 400 $^\circ\text{C}$ (–110 to +2 552 $^\circ\text{F}$) based on the International Temperature Scale (ITS90). Calibrations are traceable to national and international

standards. The calibration certificate is referenced to the serial number of the thermometer. Only the insert is calibrated.

Insert: Ø 6 mm (0.24 in) and 3 mm (0.12 in)	Minimum insertion length of insert in mm (in)	
	without head transmitter	with head transmitter
Temperature range		
-80 to -40 °C (-110 to -40 °F)	200 (7.87)	
-40 to 0 °C (-40 to 32 °F)	160 (6.3)	
0 to 250 °C (32 to 480 °F)	120 (4.72)	150 (5.91)
250 to 550 °C (480 to 1 020 °F)	300 (11.81)	
550 to 1 400 °C (1 020 to 2 552 °F)	450 (17.72)	

Material

Extension neck, insert

The temperatures for continuous operation specified in the following table are only intended as reference values for use of the various materials in air and without any significant compressive load. The maximum operating temperatures are reduced considerably in some cases where abnormal conditions such as high mechanical load occur or in aggressive media.

Designation	Short form	Recommended max. temperature for continuous use in air	Properties
AISI 316/1.4401	X5CrNiMo 17-12-2	650 °C (1 202 °F) ¹⁾	<ul style="list-style-type: none"> ■ Austenitic, stainless steel ■ High corrosion resistance in general ■ Particularly high corrosion-resistance in chlorine-based and acidic, non-oxidizing atmospheres through the addition of molybdenum (e.g. phosphoric and sulfuric acids, acetic and tartaric acids with a low concentration)
AISI 316L/ 1.4404 1.4435	X2CrNiMo17-12-2 X2CrNiMo18-14-3	650 °C (1 202 °F) ¹⁾	<ul style="list-style-type: none"> ■ Austenitic, stainless steel ■ High corrosion resistance in general ■ Particularly high corrosion-resistance in chlorine-based and acidic, non-oxidizing atmospheres through the addition of molybdenum (e.g. phosphoric and sulfuric acids, acetic and tartaric acids with a low concentration) ■ Increased resistance to intergranular corrosion and pitting ■ Compared to 1.4404, 1.4435 has even higher corrosion resistance and a lower delta ferrite content
AISI A105/1.0460	C22.8	450 °C (842 °F)	<ul style="list-style-type: none"> ■ Heat-resistant steel ■ Resistant to atmospheres which contain nitrogen and are low in oxygen; not suitable for acids or other aggressive media ■ Often used for boilers, water and steam pipes, pressure vessels
Inconel600/ 2.4816	NiCr15Fe	1 100 °C (2 012 °F)	<ul style="list-style-type: none"> ■ A nickel/chromium alloy with very good resistance to aggressive, oxidizing and reducing atmospheres, even at high temperatures ■ Resistance to corrosion caused by chlorine gases and chlorinated media as well as many oxidizing mineral and organic acids, sea water etc. ■ Corrosion from ultrapure water ■ Not to be used in sulfur-containing atmospheres

1) Can be used to a limited extent up to 800 °C (1 472 °F) for low compressive loads and in non-corrosive media. Please contact your Endress+Hauser sales team for further information.

Components

Family of temperature transmitters

Thermometers fitted with iTEMP® transmitters are an installation-ready complete solution to improve temperature measurement by significantly increasing accuracy and reliability, when compared to direct wired sensors, as well as reducing both wiring and maintenance costs.

PC-programmable TMT180 and TMT181 head transmitters

They offer a high degree of flexibility, thereby supporting universal application with low inventory storage. The iTEMP® transmitters can be configured quickly and easily at a PC. Endress+Hauser offers the ReadWin® 2000 configuration software for this purpose. This software can be downloaded free of charge at www.readwin2000.com. More information can be found in the Technical Information. (→ [17](#))

HART® TMT182 head transmitter

HART® communication is all about easy, reliable data access. It means that additional information on the measurement point can be obtained more cost-effectively. iTEMP® transmitters integrate seamlessly into your existing control system and provide trouble-free access to a wide range of diagnostic information.

Configuration is done using a hand-held device (Field Xpert SFX100 or DXR375) or a PC with configuration program (FieldCare, ReadWin® 2000). AMS or PDB can also be used for configuration purposes. More information can be found in the Technical Information. (→ [17](#))

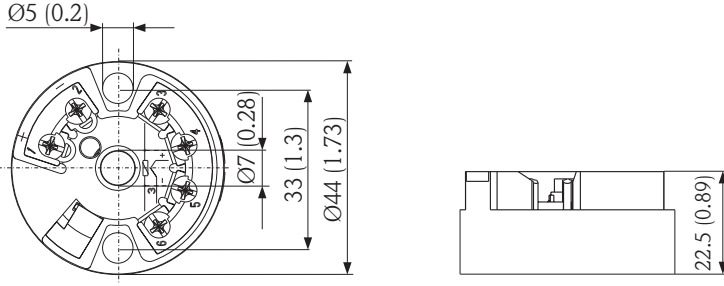
iTEMP® transmitter TMT18x	Specification
	<ul style="list-style-type: none"> ■ Material: Housing (PC), potting (PUR) ■ Terminals: Cable up to max. $\leq 2.5 \text{ mm}^2$ / AWG 16 (secure screws) or with wire end ferrules ■ Eyelets for easy connection of HART® hand-held terminals with alligator clips ■ Degree of protection NEMA Type 4x incl. (see also type of terminal head) <p>More information can be found in the Technical Information. (→ 17)</p>

HART®-programmable iTEMP® head transmitter TMT82

The iTEMP® TMT82 is a loop-powered device with two measurement inputs and one analog output. The device not only transfers converted signals from resistance thermometers and thermocouples, it also transfers resistance and voltage signals using HART® communication. It can be installed as an intrinsically safe apparatus in hazardous areas, zone 1 and is used for instrumentation purposes in the terminal head, flat face as per DIN EN 50446. Swift and easy operation, visualization and maintenance by means of a PC using configuration software such as FieldCare, Simatic PDM oder AMS. Benefits are: dual sensor input, highest reliability, accuracy and long-term stability in critical processes, mathematic functions, thermometer drift monitoring, sensor back-up functionality, sensor diagnosis functions and sensor-transmitter matching using Callendar-Van Dusen coefficients. More information can be found in the Technical Information. (→ [17](#))





PROFIBUS® PA iTEMP® head transmitter TMT84

Universally programmable head transmitter with PROFIBUS® PA communication. Conversion of various input signals into digital output signals. High accuracy over the complete ambient temperature range. Swift and easy operation, visualization and maintenance using a PC directly from the control panel, e.g. using operating software such as FieldCare, Simatic PDM or AMS. Benefits are: dual sensor input, highest reliability in harsh industrial environments, mathematic functions, thermometer drift monitoring, sensor back-up functionality, sensor diagnosis functions and sensor-transmitter matching using Callendar-Van Dusen coefficients. More information can be found in the Technical Information. (→ [17](#))

FOUNDATION Fieldbus™ iTEMP® head transmitter TMT85

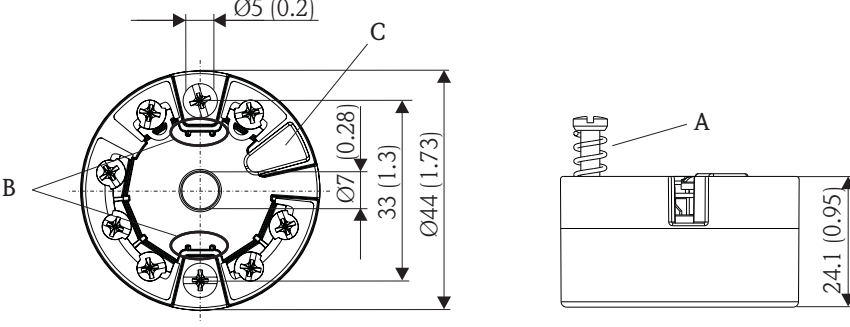
Universally programmable head transmitter with FOUNDATION Fieldbus™ communication. Conversion of various input signals into digital output signals. High accuracy over the complete ambient temperature range. Swift and easy operation, visualization and maintenance using a PC directly from the control panel, e.g. using operating software such as ControlCare from Endress+Hauser or NI Configurator from National Instruments. Benefits are: dual sensor input, highest reliability in harsh industrial environments, mathematic functions, thermometer drift monitoring, sensor back-up functionality, sensor diagnosis functions and sensor-transmitter

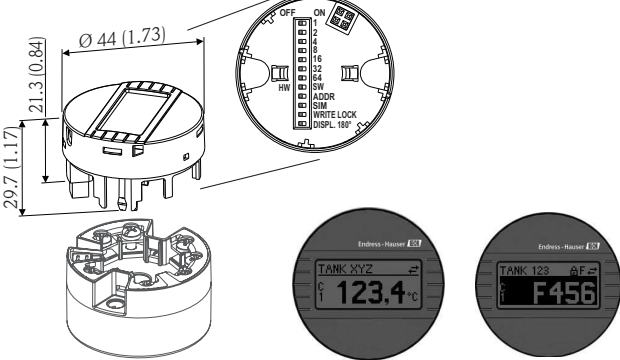
matching using Calendar-Van Dusen coefficients. More information can be found in the Technical Information. (→  17)

iTEMP® transmitter TMT8x	Specification
 <p>A0007301</p>	<ul style="list-style-type: none"> ■ Spring range $L \geq 5$ mm (0.2 in), see Pos. A ■ Fixing elements for pluggable measured value display, see Pos. B ■ Interface for contacting measured value display, see Pos. C ■ Material (RoHS-compliant) Housing: PC Potting: PU ■ Terminals: Screw terminals (cable up to max. ≤ 2.5 mm² / AWG 16) or spring terminals (0.25 to 0.75 mm²/ AWG 24 to 18 for flexible wires with wire end ferrules with plastic ferrule) ■ Degree of protection NEMA type 4x encl. (see also type of terminal head) More information can be found in the Technical Information. (→  17)
<p>Optional pluggable display TID10</p>  <p>A0009955</p>	<ul style="list-style-type: none"> ■ Displays the current measured value and measurement point identification ■ Displays fault events in inverse color with channel ident and diagnostics code ■ DIP-switches on the rear for hardware set-up, e.g. PROFIBUS® PA bus address <p> The display is compatible only with suitable terminals heads with a display window in the cover, e.g. TA30</p>

Terminal heads

All terminal heads have an internal shape and size in accordance with DIN EN 50446, flat face and a thermometer connection of M24x1.5, G1/2" or 1/2" NPT thread. All dimensions in mm (in). The cable glands in the diagrams correspond to M20x1.5 connections. Specifications without head transmitter installed. (→  4)

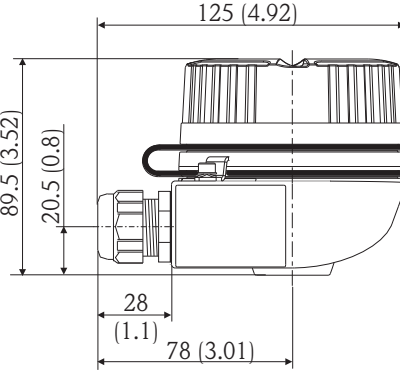
TA30H	Specification
 <p>A0009832</p>	<ul style="list-style-type: none"> ■ Flameproof (XP) version, explosion-protected, captive screw cap, available with one or two cable entries ■ Protection class: IP 66/68 ■ Temperature: -50 to +150 °C (-58 to +302 °F) for rubber seal without cable gland (observe max. permitted temperature of cable gland!) ■ Material: aluminum; polyester powder coated ■ Cable entry glands: 1/2" NPT, 3/4" NPT, M20x1.5, only thread G1/2"; connector: M12x1 PA, 7/8" FF ■ Extension neck/thermowell connection: 1/2" NPT ■ Color of head: blue, RAL 5012 ■ Color of cap: gray, RAL 7035 ■ Weight: approx. 640 g (22.6 oz)

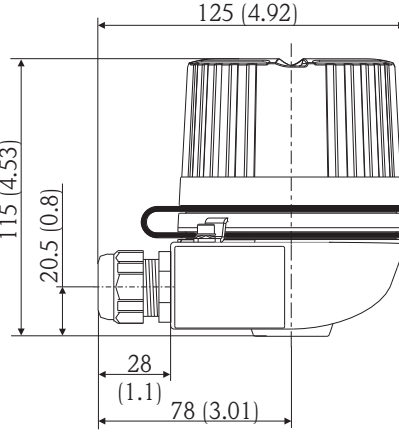
TA30H with display window in cover	Specification
 <p style="text-align: right; font-size: small;">A0009831</p>	<ul style="list-style-type: none"> ■ Flameproof (XP) version, explosion-protected, captive screw cap, available with one or two cable entries ■ Protection class: IP 66/68 ■ Temperature: -50 to +150 °C (-58 to +302 °F) for rubber seal without cable gland (observe max. permitted temperature of cable gland!) ■ Material: aluminum; polyester powder coated ■ Cable entry glands: ½" NPT, ¾" NPT, M20x1.5, only thread G½"; connector: M12x1 PA, 7/8" FF ■ Extension neck/thermowell connection: ½" NPT ■ Color of head: blue, RAL 5012 ■ Color of cap: gray, RAL 7035 ■ Weight: approx. 860 g (30.33 oz) ■ Head transmitter optionally available with TID10 display

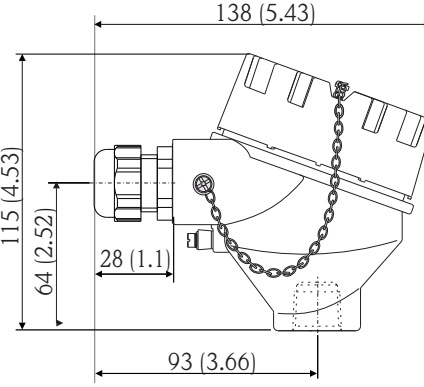
TA21H, DIN B	Specification
 <p style="text-align: right; font-size: small;">A0010194</p>	<ul style="list-style-type: none"> ■ Head with captive screw cap and safety chain ■ Protection class: IP 66/68 ■ Max. temperature: 100 °C (212 °F) for rubber seal without cable gland (observe max. permitted temperature of cable gland!) ■ Material: aluminum alloy, stainless steel; rubber seal under the cover ■ Double threaded cable entry: ½" NPT, ¾" NPT, M20 or G½" ■ Extension neck / thermowell connection: M24x1.5, G½" or ½" NPT ■ Head color: blue ■ Cap color: gray ■ Weight: approx. 600 g (21.16 oz)

Design

All dimensions in mm (in).

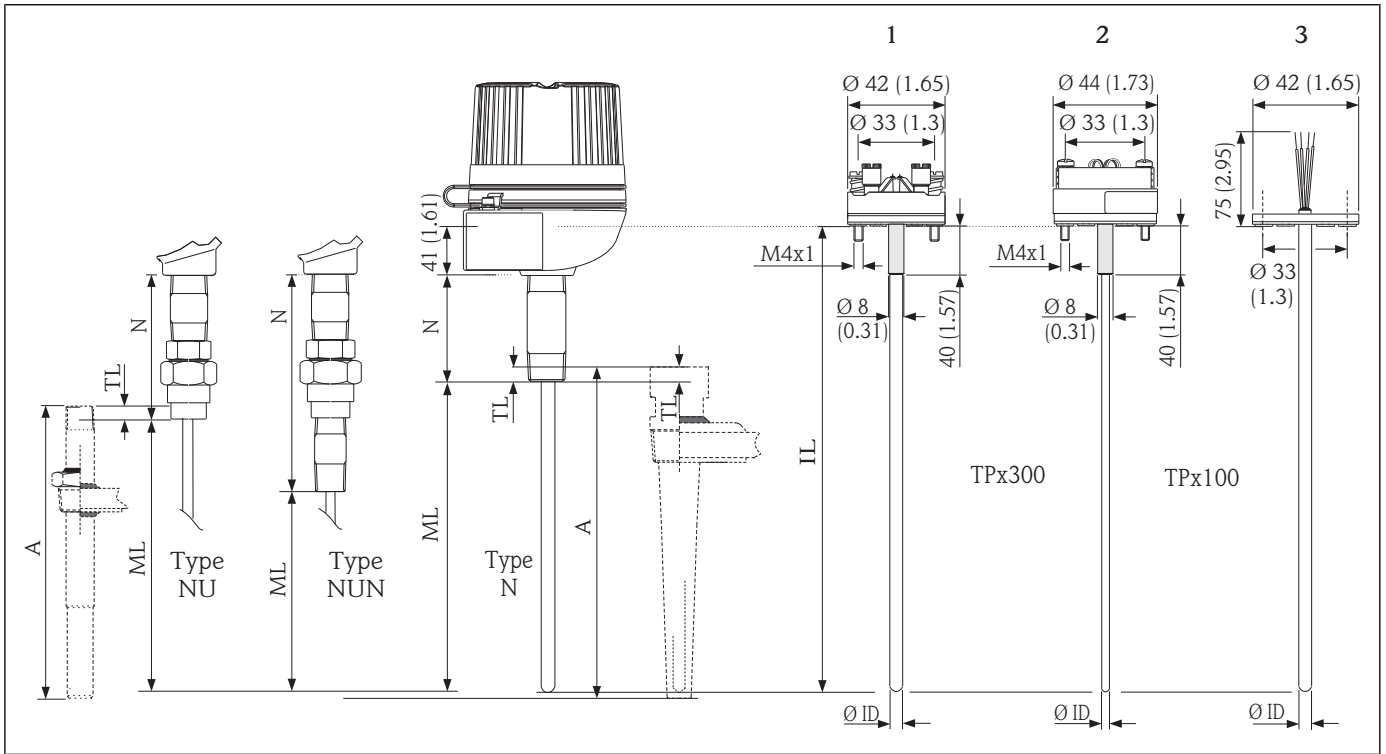

A0016337-EN

3 Dimensions of Omnigrad S TR62 and TC62

- 1 Insert with terminal block mounted
- 2 Insert with head transmitter mounted
- 3 Insert with free wires
- A Thermowell length
- TL Screw-in length
- N Extension neck length
- ML Insertion length
- IL Total length of insert
- ID Insert diameter

i The insertion length (ML) must be selected on the basis of the total length and the **type of thermowell used**.

Weight

0.5 to 2.5 kg (1 to 5.5 lbs) for standard options.

Process connection

The thermometer is designed for installation in an existing onsite thermowell or in a thermowell which can be ordered separately. The installation is done using the threaded connection on the bottom of the extension neck.

Type	Thermowell connection	Extension neck lengths in mm (in)
	Type N	77 mm (3.03 in) 117 mm (4.61 in)
	Type NU	104 mm (4.09 in)
	Type NUN	156 mm (6.14 in)

A0016409-EN

Spare parts

- The RTD insert is available as spare part TPR100/TPR300 (→ 17)
- The TC insert is available as spare part TPC100/TPC300 (→ 17)
- If the insert is required as a spare part, please note the following formulas:

Universal or ATEX certification						
Insert	Ø mm	Connection type	Connection type	Thermowell connection	Material	IL in mm (in)
TPx100 / TPx300	3 or 6	N	77 (3.03)	½" NPT external thread	SS316/A105	$IL = ML + 77 (3.03) + 41 (1.61)$
TPx100 / TPx300	3 or 6	N	117 (4.61)	½" NPT external thread	SS316/A105	$IL = ML + 117 (4.61) + 41 (1.61)$
TPx100 / TPx300	3 or 6	NU	104 (4.09)	½" NPT external thread	SS316/A105	$IL = ML + 104 (4.09) + 41 (1.61)$
TPx100 / TPx300	3 or 6	NUN	156 (6.14)	½" NPT external thread	SS316/A105	$IL = ML + 156 (6.14) + 41 (1.61)$

Wiring

Wiring diagrams for RTD

Type of sensor connection

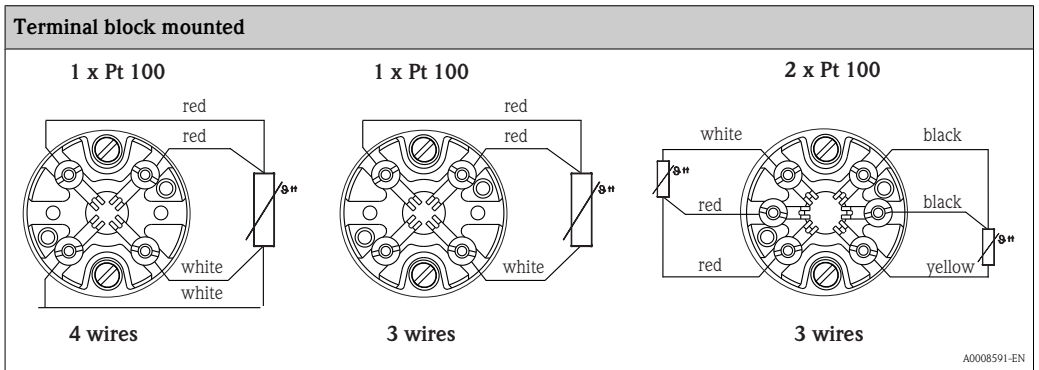
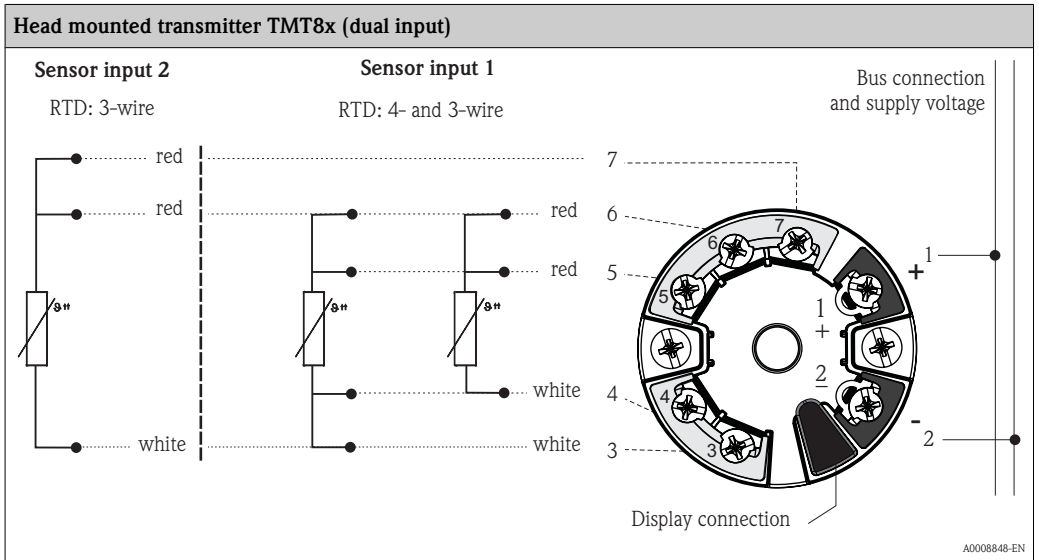
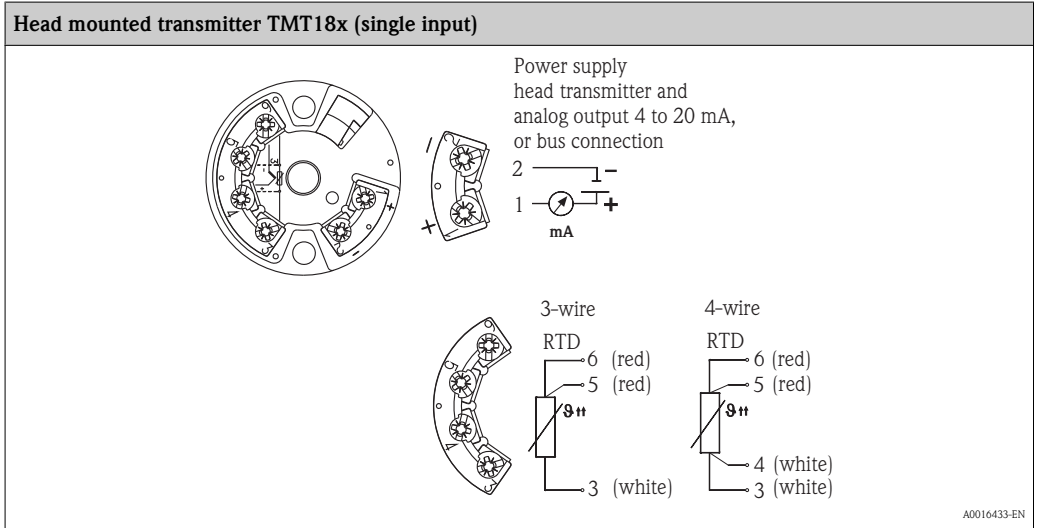

Wiring diagrams for TC

Thermocouple wire colors

As per IEC 60584	As per ASTM E230
<ul style="list-style-type: none"> ■ Type J: black (+), white (-) ■ Type K: green (+), white (-) 	<ul style="list-style-type: none"> ■ Type J: white (+), red (-) ■ Type K: yellow (+), red (-)

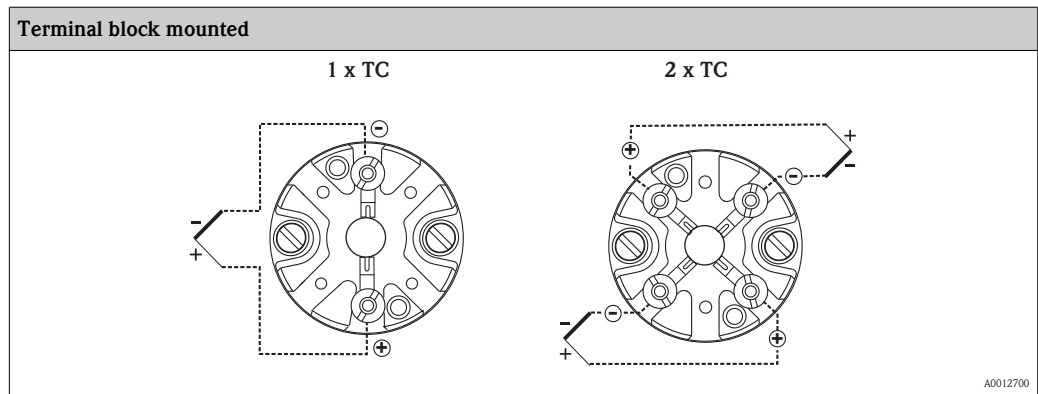
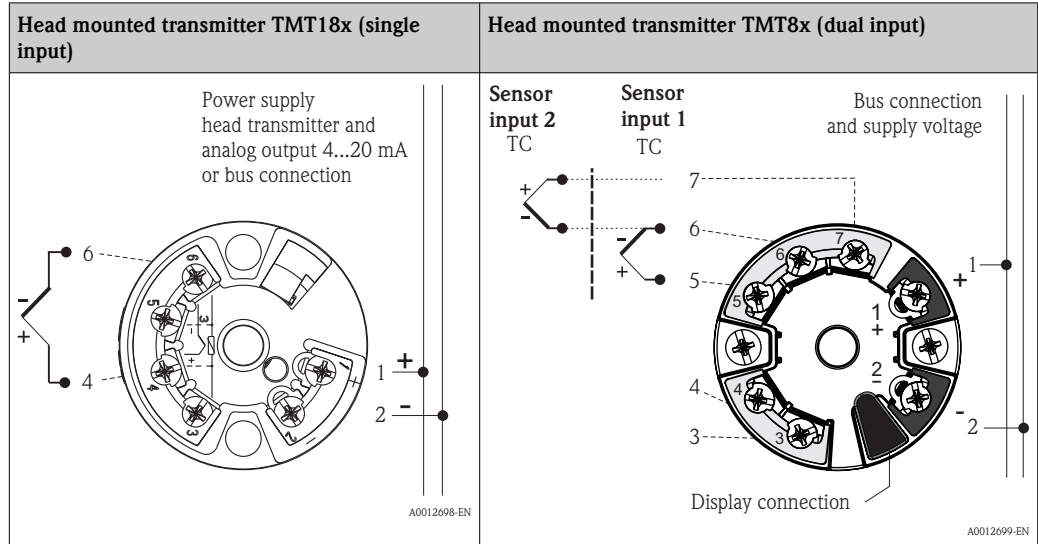

Installation conditions

Orientation No restrictions.

Installation instructions

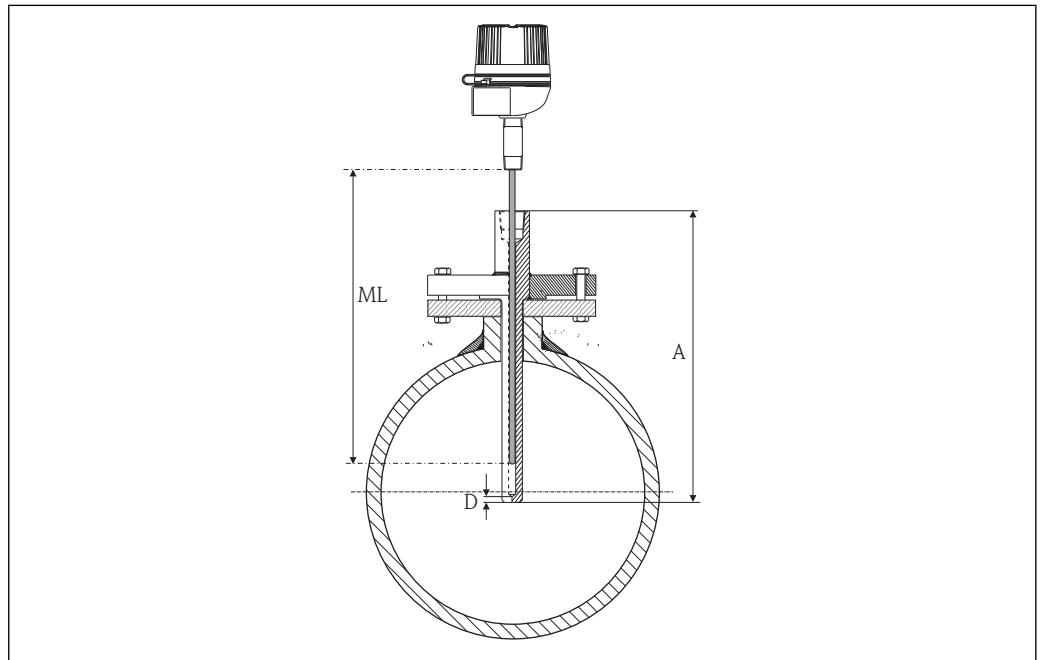

A0016635

4 Thermometer installation

The thermometer is designed for installation in an existing thermowell or in a thermowell which can be ordered separately. Different threaded connections to suit the thermowell are available on the thermometer's extension neck (→ 12). The necessary insertion length (ML) of the insert depends on the total length of the thermowell (A) and the type of thermowell used. It can be freely selected within the range of 100 to 5 000 mm (3.94 to 197 in). Longer insertion lengths are available on request. This also applies when ordering the insert as a spare part. More detailed information on determining the insertion length (ML) required in each case can be found in the following table (applies to Endress+ Hauser thermowells with standard base thicknesses (D)).

Thermowell type	ML in mm (in)	Thermowell type	ML in mm (in)
TA535	ML = A - 8 (0.31)	TA565	ML = A - 11 (0.43)
TA540	ML = A - 10 (0.39)	TA566	
TA550	ML = A - 11 (0.43)	TA570	
TA555	ML = A - 10 (0.39)	TA571	
TA557	ML = A - 10 (0.39)	TA572	
TA560	ML = A - 11 (0.43)	TA575	
TA562		TA576	ML = A - 10 (0.39)

In the case of thermowells with a non-compliant standard base thickness (D), the following formula must be used: **ML = A - D + 3 (0.12)** in mm (in).

Extension neck length

The extension neck is the part between the process connection and the terminal head. As illustrated in the following diagram, the extension neck length influences the temperature in the terminal head. This temperature must remain within the limit values defined in the "Operating conditions" section.

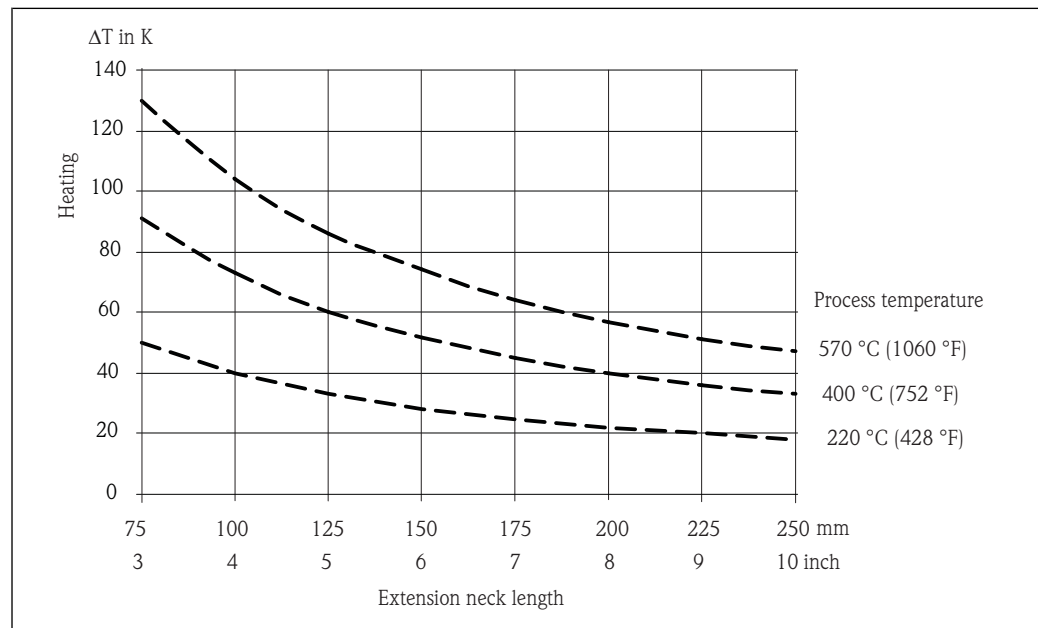

A0010513-EN

5 Heating of the terminal head as a function of the process temperature. Temperature in terminal head = ambient temperature 20 °C (68 °F) + ΔT

Certificates and approvals

CE Mark

The device meets the legal requirements of the EC directives if applicable. Endress+Hauser confirms that the device has been successfully tested by applying the CE mark.

Hazardous area approvals

For further details on the available Ex versions (ATEX, CSA, FM etc.), please contact your nearest Endress +Hauser sales organization. All relevant data for hazardous areas can be found in separate Ex documentation.

Other standards and guidelines

- EN 60079: ATEX certification for hazardous areas
- IEC 60529: Degree of protection of housing (IP code)
- IEC 61010-1: Protection Measures for Electrical Equipment for Measurement, Control, Regulation and Laboratory Procedures.
- IEC 60751: Industrial platinum resistance thermometers
- IEC 60584 and ASTM E230/ANSI MC96.1: Thermocouples
- DIN EN 50446: Terminal heads
- IEC 61326-1: Electromagnetic compatibility (EMC requirements)

PED approval

The thermometer complies with paragraph 3.3 of the Pressure Equipment Directive 97/23/CE and is not marked separately.

Test report and calibration

The "Factory calibration" is carried out according to an internal procedure in a laboratory of Endress+Hauser accredited by the European Accreditation Organization (EA) to ISO/IEC 17025. A calibration which is performed according to EA guidelines (SIT or DKD calibration) may be requested separately. The calibration is performed on the replaceable insert of the thermometer. In the case of thermometers without a replaceable insert, the entire thermometer - from the process connection to the tip of the thermometer - is calibrated.

Ordering information

Detailed ordering information is available from the following sources:

- In the Product Configurator on the Endress+Hauser website: www.endress.com → Select country → Instruments → Select device → Product page function: Configure this product
- From your Endress+Hauser Sales Center: www.endress.com/worldwide



Product Configurator - the tool for individual product configuration

- Up-to-the-minute configuration data
 - Depending on the device: Direct input of measuring point-specific information such as measuring range or operating language
 - Automatic verification of exclusion criteria
 - Automatic creation of the order code and its breakdown in PDF or Excel output format
 - Ability to order directly in the Endress+Hauser Online Shop

Documentation

Technical Information

- Temperature head transmitter
 - iTEMP® TMT180, PC-programmable, single-channel, Pt100 (TI088R/09/en)
 - iTEMP® PCP TMT181, PC-programmable, single-channel, RTD, TC, Ω, mV (TI00070R/09/en)
 - iTEMP® HART® TMT182, single-channel, RTD, TC, Ω, mV (TI078R/09/en)
 - iTEMP® HART® TMT82, two-channel, RTD, TC, Ω, mV (TI01010T/09/en)
 - iTEMP® PROFIBUS® PA TMT84, two-channel, RTD, TC, Ω, mV (TI138R/09/en)
 - iTEMP® FOUNDATION Fieldbus™ TMT85, two-channel, RTD, TC, Ω, mV (TI134R/09/en)
- Inserts:
 - Resistance thermometer insert Omniset TPR100 (TI268t/02/en)
 - Thermocouple insert Omniset TPC100 (TI278t/02/en)
- Application example:
 - RN221N Active barrier, for supplying loop-powered transmitters (TI073R/09/en)
 - RIA16 Field display unit, loop-powered (TI00144R/09/en)

Technical Information on thermowells:

Thermowell type			
TA535	TI250t/02/en	TA565	TI160t/02/en
TA540	TI00166T/09/en	TA566	TI177t/02/en
TA550	TI153t/02/en	TA570	TI161t/02/en
TA555	TI154t/02/en	TA571	TI178t/02/en
TA557	TI156t/02/en	TA572	TI179t/02/en
TA560	TI159t/02/en	TA575	TI162t/02/en
TA562	TI230t/02/en	TA576	TI163t/02/en

Supplementary ATEX documentation:

- RTD/TC Thermometer Omnigrad TRxx, TCxx, TxCxxx, ATEX II 1GD or II 1/2GD Ex ia IIC T6 to T1 (XA072R/09/a3)
- RTD/TC Thermometer Omnigrad S TR/TC6x, ATEX III 1/2, 2GD or II2G (XA014T/02/a3)
- RTD/TC Thermometer Omnigrad S TR/TC6x, ATEX II 1/2 or 2G; II 1/2 or 2D; II 2G (XA084R/09/a3)
- Inserts Omniset TPR100, TPC100, ATEX II 1G (XA087R/09/a3)
- Inserts Omniset TPR100, TPC100, ATEX/IECEx Ex ia (XA00100T/09/a3)

Instruments International

Endress+Hauser
Instruments International AG
Kaegenstrasse 2
4153 Reinach
Switzerland

Tel.+41 61 715 81 00
Fax+41 61 715 25 00
www.endress.com
info@ii.endress.com

Endress + Hauser 
People for Process Automation
