

Technical Information

Proline Promag E 100

Electromagnetic flowmeter



The economical flowmeter with an ultra-compact transmitter

Application

- The measuring principle is virtually independent of pressure, density, temperature and viscosity
- Fully suitable for basic applications in the chemical and process industry

Device properties

- Nominal diameter: max. DN 600 (24")
- Ex approvals for Zone 2
- Liner made of PTFE
- Robust, ultra-compact transmitter housing
- Local display available

Your benefits

- Cost-effective sensor – ideal solution for basic requirements
- Energy-saving flow measurement – no pressure loss due to cross-section constriction
- Maintenance-free – no moving parts
- Space-saving transmitter – full functionality on the smallest footprint
- Time-saving local operation without additional software and hardware – integrated web server
- Integrated verification – Heartbeat Technology™







Table of contents

Document information	3	Process	35
Symbols used	3	Medium temperature range	35
Function and system design	4	Conductivity	35
Measuring principle	4	Pressure-temperature ratings	35
Measuring system	5	Pressure tightness	36
Device architecture	6	Flow limit	37
Safety	6	Pressure loss	37
Input	6	System pressure	37
Measured variable	6	Vibrations	37
Measuring range	6	Mechanical construction	38
Operable flow range	8	Design, dimensions	38
Input signal	8	Weight	42
Output	8	Measuring tube specification	43
Output signal	8	Materials	44
Signal on alarm	10	Fitted electrodes	45
Low flow cut off	12	Process connections	45
Galvanic isolation	12	Surface roughness	45
Protocol-specific data	12	Operability	45
Power supply	17	Operating concept	45
Terminal assignment	17	Local display	46
Pin assignment, device plug	21	Remote operation	46
Supply voltage	23	Service interface	47
Power consumption	23	Certificates and approvals	49
Current consumption	23	CE mark	49
Power supply failure	23	C-Tick symbol	49
Electrical connection	24	Ex approval	50
Ensuring potential equalization	28	Certification PROFIBUS	50
Terminals	28	Modbus RS485 certification	50
Cable entries	28	EtherNet/IP certification	50
Cable specification	28	Pressure Equipment Directive	50
Performance characteristics	29	Other standards and guidelines	50
Reference operating conditions	29	Ordering information	51
Maximum measured error	30	Application packages	51
Repeatability	30	Cleaning	51
Temperature measurement response time	30	Heartbeat Technology	51
Influence of ambient temperature	30	Accessories	52
Installation	31	Device-specific accessories	52
Mounting location	31	Communication-specific accessories	52
Orientation	32	Service-specific accessories	53
Inlet and outlet runs	32	System components	53
Adapters	33	Supplementary documentation	53
Environment	33	Standard documentation	53
Ambient temperature range	33	Supplementary device-dependent documentation	54
Storage temperature	34	Registered trademarks	54
Degree of protection	34		
Shock resistance	34		
Vibration resistance	34		
Mechanical load	34		
Electromagnetic compatibility (EMC)	34		









Document information

Symbols used

Electrical symbols



Symbol	Meaning
	Direct current A terminal to which DC voltage is applied or through which direct current flows.
	Alternating current A terminal to which alternating voltage is applied or through which alternating current flows.
	Direct current and alternating current <ul style="list-style-type: none"> ▪ A terminal to which alternating voltage or DC voltage is applied. ▪ A terminal through which alternating current or direct current flows.
	Ground connection A grounded terminal which, as far as the operator is concerned, is grounded via a grounding system.
	Protective ground connection A terminal which must be connected to ground prior to establishing any other connections.
	Equipotential connection A connection that has to be connected to the plant grounding system: This may be a potential equalization line or a star grounding system depending on national or company codes of practice.

Symbols for certain types of information

Symbol	Meaning
	Permitted Indicates procedures, processes or actions that are permitted.
	Preferred Indicates procedures, processes or actions that are preferred.
	Forbidden Indicates procedures, processes or actions that are forbidden.
	Tip Indicates additional information.
	Reference to documentation Refers to the corresponding device documentation.
	Reference to page Refers to the corresponding page number.
	Reference to graphic Refers to the corresponding graphic number and page number.
	Visual inspection

Symbols in graphics

Symbol	Meaning
1, 2, 3, ...	Item numbers
1., 2., 3., ...	Series of steps
A, B, C, ...	Views
A-A, B-B, C-C, ...	Sections
	Flow direction

Symbol	Meaning
	Hazardous area Indicates a hazardous area.
	Safe area (non-hazardous area) Indicates the non-hazardous area.

Function and system design

Measuring principle

Following *Faraday's law of magnetic induction*, a voltage is induced in a conductor moving through a magnetic field.

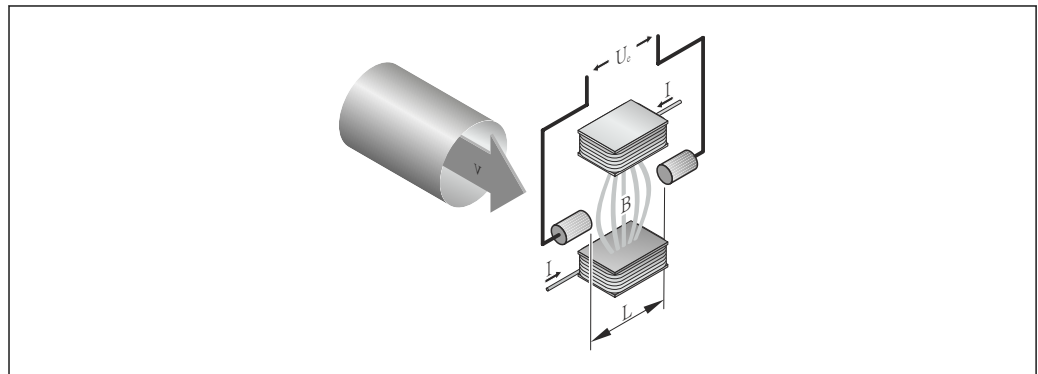

U_e Induced voltage
 B Magnetic induction (magnetic field)
 L Electrode spacing
 I Current
 v Flow velocity

In the electromagnetic measuring principle, the flowing medium is the moving conductor. The voltage induced (U_e) is proportional to the flow velocity (v) and is supplied to the amplifier by means of two measuring electrodes. The flow volume (Q) is calculated via the pipe cross-section (A). The DC magnetic field is created through a switched direct current of alternating polarity.

Formulae for calculation

- Induced voltage $U_e = B \cdot L \cdot v$
- Volume flow $Q = A \cdot v$

Measuring system

One device version is available: compact version, transmitter and sensor form a mechanical unit.

Transmitter

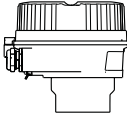
<p>Promag 100</p>  <p style="text-align: right; font-size: small;">A0016693</p>	<p>Device versions and materials: Compact, aluminum coated: Aluminum, AlSi10Mg, coated</p> <p>Configuration:</p> <ul style="list-style-type: none"> ■ Via operating tools (e.g. FieldCare) ■ Additionally for device version with onsite display: Via Web browser (e.g. Microsoft Internet Explorer) ■ Also for device version with 4-20 mA HART, pulse/frequency/switch output: Via Web browser (e.g. Microsoft Internet Explorer) ■ Also for device version with EtherNet/IP output: <ul style="list-style-type: none"> - Via Web browser (e.g. Microsoft Internet Explorer) - Via Add-on Profile Level 3 for automation system from Rockwell Automation - Via Electronic Data Sheet (EDS)
---	--

Sensor

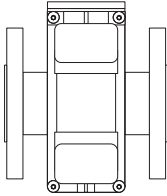
<p>Promag E</p>  <p style="text-align: right; font-size: small;">A0017703</p>	<p>Nominal diameter range: DN 15 to 600 (½ to 24")</p> <p>Materials:</p> <ul style="list-style-type: none"> ■ Sensor housing: <ul style="list-style-type: none"> - Aluminum, AlSi10Mg, coated - DN 15 to 300 (½ to 12"): aluminum, AlSi10Mg, coated - DN 350 to 600 (14 to 24"): carbon steel with protective varnish ■ Measuring tubes ¹⁾: stainless steel, 1.4301/1.4306 ■ Liner: PTFE ■ Electrodes: stainless steel, 1.4435 (F316L); Alloy C22, 2.4602 (UNS N06022); tantalum ■ Process connections: carbon steel, A105/FE410WB ²⁾/HII/S235JRG2/S275JR; Alloy C22, 2.4602 (UNS N06022) ■ Seals: as per DIN EN 1514-1 ■ Ground disks: stainless steel, 1.4435 (316L); Alloy C22, 2.4602 (UNS N06022); tantalum; titanium
--	---

- 1) For flanges made of carbon steel with Al/Zn protective coating (DN 15 to 300 (½ to 12")) or protective varnish (DN 350 to 600 (14 to 24"))
- 2) With Al/Zn protective coating (DN 15 to 300 (½ to 12")) or protective varnish (DN 350 to 600 (14 to 24"))

Device architecture

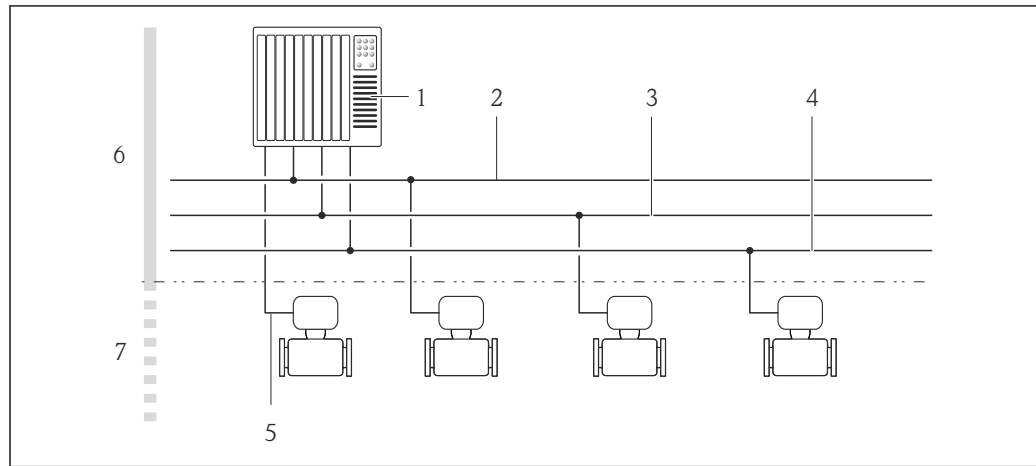

A0021560

1 Possibilities for integrating measuring devices into a system

- 1 Control system (e.g. PLC)
- 2 EtherNet/IP
- 3 PROFIBUS DP
- 4 Modbus RS485
- 5 4-20 mA HART, pulse/frequency/switch output
- 6 Non-hazardous area
- 7 Non-hazardous area and Zone 2/Div. 2

Safety

IT security

We only provide a warranty if the device is installed and used as described in the Operating Instructions. The device is equipped with security mechanisms to protect it against any inadvertent changes to the device settings.

IT security measures in line with operators' security standards and designed to provide additional protection for the device and device data transfer must be implemented by the operators themselves.

Input

Measured variable

Direct measured variables

- Volume flow (proportional to induced voltage)
- Electrical conductivity

Calculated measured variables

- Mass flow
- Corrected volume flow

Measuring range

Typically $v = 0.01$ to 10 m/s (0.03 to 33 ft/s) with the specified accuracy

Electrical conductivity: 5 to 10000 $\mu\text{S}/\text{cm}/\text{cm}$

Flow characteristic values in SI units

Nominal diameter		Recommended flow min./max. full scale value ($v \sim 0.3/10$ m/s) [dm ³ /min]	Factory settings		
[mm]	[in]		Current output full scale value ¹⁾ ($v \sim 2.5$ m/s) [dm ³ /min]	Pulse value ¹⁾ (~ 2 pulse/s) [dm ³]	Low flow cut off ($v \sim 0.04$ m/s) [dm ³ /min]
15	½	4 to 100	25	0.2	0.5
25	1	9 to 300	75	0.5	1
32	–	15 to 500	125	1	2

Nominal diameter		Recommended flow min./max. full scale value (v ~ 0.3/10 m/s)	Factory settings		
[mm]	[in]		Current output full scale value ¹⁾ (v ~ 2.5 m/s)	Pulse value ¹⁾ (~ 2 pulse/s)	Low flow cut off (v ~ 0.04 m/s)
		[dm ³ /min]	[dm ³ /min]	[dm ³]	[dm ³ /min]
40	1 ½	25 to 700	200	1.5	3
50	2	35 to 1 100	300	2.5	5
65	–	60 to 2 000	500	5	8
80	3	90 to 3 000	750	5	12
100	4	145 to 4 700	1200	10	20
125	–	220 to 7 500	1850	15	30
150	6	20 to 600 m ³ /h	150 m ³ /h	0.03 m ³	2.5 m ³ /h
200	8	35 to 1 100 m ³ /h	300 m ³ /h	0.05 m ³	5 m ³ /h
250	10	55 to 1 700 m ³ /h	500 m ³ /h	0.05 m ³	7.5 m ³ /h
300	12	80 to 2 400 m ³ /h	750 m ³ /h	0.1 m ³	10 m ³ /h
350	14	110 to 3 300 m ³ /h	1 000 m ³ /h	0.1 m ³	15 m ³ /h
400	16	140 to 4 200 m ³ /h	1 200 m ³ /h	0.15 m ³	20 m ³ /h
450	18	180 to 5 400 m ³ /h	1 500 m ³ /h	0.25 m ³	25 m ³ /h
500	20	220 to 6 600 m ³ /h	2 000 m ³ /h	0.25 m ³	30 m ³ /h
600	24	310 to 9 600 m ³ /h	2 500 m ³ /h	0.3 m ³	40 m ³ /h



1) HART only

Flow characteristic values in US units

Nominal diameter		Recommended flow min./max. full scale value (v ~ 0.3/10 m/s)	Factory settings		
[in]	[mm]		Current output full scale value ¹⁾ (v ~ 2.5 m/s)	Pulse value ¹⁾ (~ 2 pulse/s)	Low flow cut off (v ~ 0.04 m/s)
		[gal/min]	[gal/min]	[gal]	[gal/min]
½	15	1.0 to 27	6	0.1	0.15
1	25	2.5 to 80	18	0.2	0.25
1 ½	40	7 to 190	50	0.5	0.75
2	50	10 to 300	75	0.5	1.25
3	80	24 to 800	200	2	2.5
4	100	40 to 1 250	300	2	4
6	150	90 to 2 650	600	5	12
8	200	155 to 4 850	1200	10	15
10	250	250 to 7 500	1500	15	30
12	300	350 to 10 600	2400	25	45
14	350	500 to 15 000	3600	30	60
16	400	600 to 19 000	4800	50	60
18	450	800 to 24 000	6000	50	90

Nominal diameter		Recommended flow min./max. full scale value (v ~ 0.3/10 m/s)	Factory settings		
			Current output full scale value ¹⁾ (v ~ 2.5 m/s)	Pulse value ¹⁾ (~ 2 pulse/s)	Low flow cut off (v ~ 0.04 m/s)
[in]	[mm]	[gal/min]	[gal/min]	[gal]	[gal/min]
20	500	1 000 to 30 000	7500	75	120
24	600	1 400 to 44 000	10500	100	180

1) HART only

 To calculate the measuring range, use the *Applicator* sizing tool (→  53)

Recommended measuring range

"Flow limit" section (→  37)

Operable flow range

Over 1000 : 1

Input signal

External measured values

To increase the accuracy of certain measured variables or to calculate the corrected volume flow, the automation system can continuously write different measured values to the measuring device:

- Operating pressure to increase accuracy (Endress+Hauser recommends the use of a pressure measuring device for absolute pressure, e.g. Cerabar M or Cerabar S)
- Medium temperature to increase accuracy (e.g. iTEMP)
- Reference density for calculating the corrected volume flow

 Various pressure transmitters and temperature measuring devices can be ordered from Endress +Hauser: see "Accessories" section (→  53)

It is recommended to read in external measured values to calculate the following measured variables:
Corrected volume flow

HART protocol

The measured values are written from the automation system to the measuring device via the HART protocol. The pressure transmitter must support the following protocol-specific functions:

- HART protocol
- Burst mode

Fieldbuses

The measured values can be written from the automation system to the measuring via:

- PROFIBUS DP
- Modbus RS485
- EtherNet/IP

Output

Output signal

Current output

Current output	4-20 mA HART (active)
Maximum output values	<ul style="list-style-type: none"> ▪ DC 24 V (no flow) ▪ 22.5 mA
Load	0 to 700 Ω
Resolution	0.38 μA

Damping	Adjustable: 0.07 to 999 s
Assignable measured variables	<ul style="list-style-type: none"> ▪ Volume flow ▪ Mass flow ▪ Corrected volume flow ▪ Flow velocity ▪ Conductivity ▪ Corrected conductivity ▪ Temperature ▪ Electronic temperature

Pulse/frequency/switch output

Function	Can be set to pulse, frequency or switch output
Version	Passive, open collector
Maximum input values	<ul style="list-style-type: none"> ▪ DC 30 V ▪ 25 mA
Voltage drop	For 25 mA: ≤ DC 2 V
Pulse output	
Pulse width	Adjustable: 0.05 to 2 000 ms
Maximum pulse rate	10 000 Impulse/s
Pulse value	Adjustable
Assignable measured variables	<ul style="list-style-type: none"> ▪ Volume flow ▪ Mass flow ▪ Corrected volume flow
Frequency output	
Output frequency	Adjustable: 0 to 10 000 Hz
Damping	Adjustable: 0 to 999 s
Pulse/pause ratio	1:1
Assignable measured variables	<ul style="list-style-type: none"> ▪ Volume flow ▪ Mass flow ▪ Corrected volume flow ▪ Flow velocity ▪ Conductivity ▪ Corrected conductivity ▪ Temperature ▪ Electronic temperature
Switch output	
Switching behavior	Binary, conductive or non-conductive
Switching delay	Adjustable: 0 to 100 s

Number of switching cycles	Unlimited
Assignable functions	<ul style="list-style-type: none"> ■ Off ■ On ■ Diagnostic behavior ■ Limit value: <ul style="list-style-type: none"> - Off - Volume flow - Mass flow - Corrected volume flow - Flow velocity - Conductivity - Corrected conductivity - Totalizer 1-3 - Temperature - Electronic temperature ■ Flow direction monitoring ■ Status <ul style="list-style-type: none"> - Empty pipe detection - Low flow cut off

PROFIBUS DP

Signal encoding	NRZ code
Data transfer	9.6 kBaud...12 MBaud

Modbus RS485

Physical interface	In accordance with EIA/TIA-485-A standard
Terminating resistor	Integrated, can be activated via DIP switch on the transmitter electronics module

EtherNet/IP

Standards	In accordance with IEEE 802.3
------------------	-------------------------------

Signal on alarm

Depending on the interface, failure information is displayed as follows:

Current output

4-20 mA

Failure mode	Selectable (as per NAMUR recommendation NE 43): <ul style="list-style-type: none"> ■ Minimum value: 3.6 mA ■ Maximum value: 22 mA ■ Defined value: 3.59 to 22.5 mA ■ Actual value ■ Last valid value
---------------------	---

HART

Device diagnostics	Device condition can be read out via HART Command 48
---------------------------	--

Pulse/frequency/switch output

Pulse output	
Failure mode	Choose from: <ul style="list-style-type: none"> ■ Actual value ■ No pulses

Frequency output	
Failure mode	Choose from: <ul style="list-style-type: none"> ▪ Actual value ▪ Defined value: 0 to 12 500 Hz ▪ 0 Hz
Switch output	
Failure mode	Choose from: <ul style="list-style-type: none"> ▪ Current status ▪ Open ▪ Closed

PROFIBUS DP

Status and alarm messages	Diagnostics in accordance with PROFIBUS PA Profile 3.02
---------------------------	---

Modbus RS485

Failure mode	Choose from: <ul style="list-style-type: none"> ▪ NaN value instead of current value ▪ Last valid value
--------------	---

EtherNet/IP

Device diagnostics	Device condition can be read out in Input Assembly
--------------------	--

Local display

Plain text display	With information on cause and remedial measures
Backlight	Red backlighting indicates a device error.

 Status signal as per NAMUR recommendation NE 107

Operating tool

- Via digital communication:
 - HART protocol
 - PROFIBUS DP
 - Modbus RS485
 - EtherNet/IP
- Via service interface

Plain text display	With information on cause and remedial measures
--------------------	---

 Additional information on remote operation (→  46)

Web browser

Plain text display	With information on cause and remedial measures
--------------------	---

Light emitting diodes (LED)

Status information	<p>Status indicated by various light emitting diodes</p> <p>The following information is displayed depending on the device version:</p> <ul style="list-style-type: none"> ■ Supply voltage active ■ Data transmission active ■ Device alarm/error has occurred ■ EtherNet/IP network available ■ EtherNet/IP connection established
---------------------------	---

Low flow cut off The switch points for low flow cut off are user-selectable.

Galvanic isolation The following connections are galvanically isolated from each other:

- Outputs
- Power supply

Protocol-specific data HART

Manufacturer ID	0x11
Device type ID	0x3A
HART protocol revision	7.0
Device description files (DTM, DD)	Information and files under: www.endress.com
HART load	Min. 250 Ω
Dynamic variables	<p>Read out the dynamic variables: HART command 3</p> <p>The measured variables can be freely assigned to the dynamic variables.</p> <p>Measured variables for PV (primary dynamic variable)</p> <ul style="list-style-type: none"> ■ Off ■ Volume flow ■ Mass flow ■ Corrected volume flow ■ Flow velocity ■ Temperature ■ Electronic temperature <p>Measured variables for SV, TV, QV (secondary, tertiary and quaternary dynamic variable)</p> <ul style="list-style-type: none"> ■ Volume flow ■ Mass flow ■ Corrected volume flow ■ Flow velocity ■ Temperature ■ Electronic temperature ■ Totalizer 1 ■ Totalizer 2 ■ Totalizer 3
Device variables	<p>Read out the device variables: HART command 9</p> <p>The device variables are permanently assigned.</p> <p>A maximum of 8 device variables can be transmitted:</p> <ul style="list-style-type: none"> ■ 0 = volume flow ■ 1 = mass flow ■ 2 = corrected volume flow ■ 3 = flow velocity ■ 4 = conductivity ■ 5 = corrected conductivity ■ 6 = temperature ■ 7 = electronic temperature ■ 8 = totalizer 1 ■ 9 = totalizer 2 ■ 10 = totalizer 3

PROFIBUS DP

Manufacturer ID	0x11
Ident number	0x1561
Profile version	3.02
Device description files (GSD, DTM, DD)	Information and files under: <ul style="list-style-type: none"> ▪ www.endress.com ▪ www.profibus.org
Output values (from measuring device to automation system)	
Input values (from automation system to measuring device)	<p>Analog output 1 (fixed assignment) External density</p> <p>Digital output 1 to 2 (fixed assignment)</p> <ul style="list-style-type: none"> ▪ Digital output 1: switch positive zero return on/off ▪ Digital output 2: start verification <p>Totalizer 1 to 3</p> <ul style="list-style-type: none"> ▪ Totalize ▪ Reset and hold ▪ Preset and hold ▪ Stop ▪ Operating mode configuration: <ul style="list-style-type: none"> - Net flow total - Forward flow total - Reverse flow total
Supported functions	<ul style="list-style-type: none"> ▪ Identification & Maintenance Simplest device identification on the part of the control system and nameplate ▪ PROFIBUS upload/download Reading and writing parameters is up to ten times faster with PROFIBUS upload/download ▪ Condensed status Simplest and self-explanatory diagnostic information by categorizing diagnostic messages that occur
Configuration of the device address	<ul style="list-style-type: none"> ▪ DIP switches on the I/O electronics module ▪ Via operating tools (e.g. FieldCare)

Modbus RS485

Protocol	Modbus Applications Protocol Specification V1.1
Device type	Slave
Slave address range	1 to 247
Broadcast address range	0
Function codes	<ul style="list-style-type: none"> ▪ 03: Read holding register ▪ 04: Read input register ▪ 06: Write single registers ▪ 08: Diagnostics ▪ 16: Write multiple registers ▪ 23: Read/write multiple registers
Broadcast messages	Supported by the following function codes: <ul style="list-style-type: none"> ▪ 06: Write single registers ▪ 16: Write multiple registers ▪ 23: Read/write multiple registers

Supported baud rate	<ul style="list-style-type: none"> ▪ 1 200 BAUD ▪ 2 400 BAUD ▪ 4 800 BAUD ▪ 9 600 BAUD ▪ 19 200 BAUD ▪ 38 400 BAUD ▪ 57 600 BAUD ▪ 115 200 BAUD
Data transfer mode	<ul style="list-style-type: none"> ▪ ASCII ▪ RTU
Data access	<p>Each device parameter can be accessed via Modbus RS485.</p> <p> For Modbus register information</p>

EtherNet/IP

Protocol	<ul style="list-style-type: none"> ▪ The CIP Networks Library Volume 1: Common Industrial Protocol ▪ The CIP Networks Library Volume 2: EtherNet/IP Adaptation of CIP 		
Communication type	<ul style="list-style-type: none"> ▪ 10Base-T ▪ 100Base-TX 		
Device profile	Generic device (product type: 0x2B)		
Manufacturer ID	0x49E		
Device type ID	0x103A		
Baud rates	Automatic ¹⁰ / ₁₀₀ Mbit with half-duplex and full-duplex detection		
Polarity	Auto-polarity for automatic correction of crossed TxD and RxD pairs		
Supported CIP connections	Max. 3 connections		
Explicit connections	Max. 6 connections		
I/O connections	Max. 6 connections (scanner)		
Configuration options for measuring device	<ul style="list-style-type: none"> ▪ DIP switches on the electronics module for IP addressing ▪ Manufacturer-specific software (FieldCare) ▪ Add-on Profile Level 3 for Rockwell Automation control systems ▪ Web browser ▪ Electronic Data Sheet (EDS) integrated in the measuring device 		
Configuration of the EtherNet interface	<ul style="list-style-type: none"> ▪ Speed: 10 MBit, 100 MBit, auto (factory setting) ▪ Duplex: half-duplex, full-duplex, auto (factory setting) 		
Configuration of the device address	<ul style="list-style-type: none"> ▪ DIP switches on the electronics module for IP addressing (last octet) ▪ DHCP ▪ Manufacturer-specific software (FieldCare) ▪ Add-on Profile Level 3 for Rockwell Automation control systems ▪ Web browser ▪ EtherNet/IP tools, e.g. RSLinx (Rockwell Automation) 		
Device Level Ring (DLR)	No		
Fix Input			
RPI	5 ms to 10 s (factory setting: 20 ms)		
Exclusive Owner Multicast		Instance	Size [byte]
	Instance configuration:	0x68	398
	O → T configuration:	0x66	56
	T → O configuration:	0x64	32
Exclusive Owner Multicast		Instance	Size [byte]
	Instance configuration:	0x69	-
	O → T configuration:	0x66	56
	T → O configuration:	0x64	32

Input only Multicast		Instance	Size [byte]
	Instance configuration:	0x68	398
	O → T configuration:	0xC7	-
	T → O configuration:	0x64	32
Input only Multicast		Instance	Size [byte]
	Instance configuration:	0x69	-
	O → T configuration:	0xC7	-
	T → O configuration:	0x64	32
Input Assembly	<ul style="list-style-type: none"> ■ Current device diagnostics ■ Volume flow ■ Mass flow ■ Corrected volume flow ■ Totalizer 1 ■ Totalizer 2 ■ Totalizer 3 		
Configurable Input			
RPI	5 ms to 10 s (factory setting: 20 ms)		
Exclusive Owner Multicast		Instance	Size [byte]
	Instance configuration:	0x68	398
	O → T configuration:	0x66	56
	T → O configuration:	0x65	88
Exclusive Owner Multicast		Instance	Size [byte]
	Instance configuration:	0x69	-
	O → T configuration:	0x66	56
	T → O configuration:	0x65	88
Input only Multicast		Instance	Size [byte]
	Instance configuration:	0x68	398
	O → T configuration:	0xC7	-
	T → O configuration:	0x65	88
Input only Multicast		Instance	Size [byte]
	Instance configuration:	0x69	-
	O → T configuration:	0xC7	-
	T → O configuration:	0x65	88
Configurable Input Assembly	<ul style="list-style-type: none"> ■ Volume flow ■ Corrected volume flow ■ Mass flow ■ Electronic temperature ■ Totalizer 1 to 3 ■ Flow velocity ■ Volume flow unit ■ Corrected volume flow unit ■ Mass flow unit ■ Temperature unit ■ Unit totalizer 1-3 ■ Flow velocity unit ■ Verification result ■ Verification status <p> The range of options increases if the measuring device has one or more application packages.</p>		

Fix Output	
Output Assembly	<ul style="list-style-type: none"> ▪ Activation of reset totalizers 1-3 ▪ Activation of reference density compensation ▪ Activation of temperature compensation ▪ Reset totalizers 1-3 ▪ External density ▪ Density unit ▪ External temperature ▪ Activation verification ▪ Start verification
Configuration	
Configuration Assembly	<p>Only the most common configurations are listed below.</p> <ul style="list-style-type: none"> ▪ Software write protection ▪ Mass flow unit ▪ Mass unit ▪ Volume flow unit ▪ Volume unit ▪ Corrected volume flow unit ▪ Corrected volume unit ▪ Density unit ▪ Reference density unit ▪ Temperature unit ▪ Pressure unit ▪ Length ▪ Totalizer 1-3: <ul style="list-style-type: none"> - Assignment - Unit - Measuring mode - Failure mode ▪ Alarm delay

Power supply

Terminal assignment

Overview: housing version

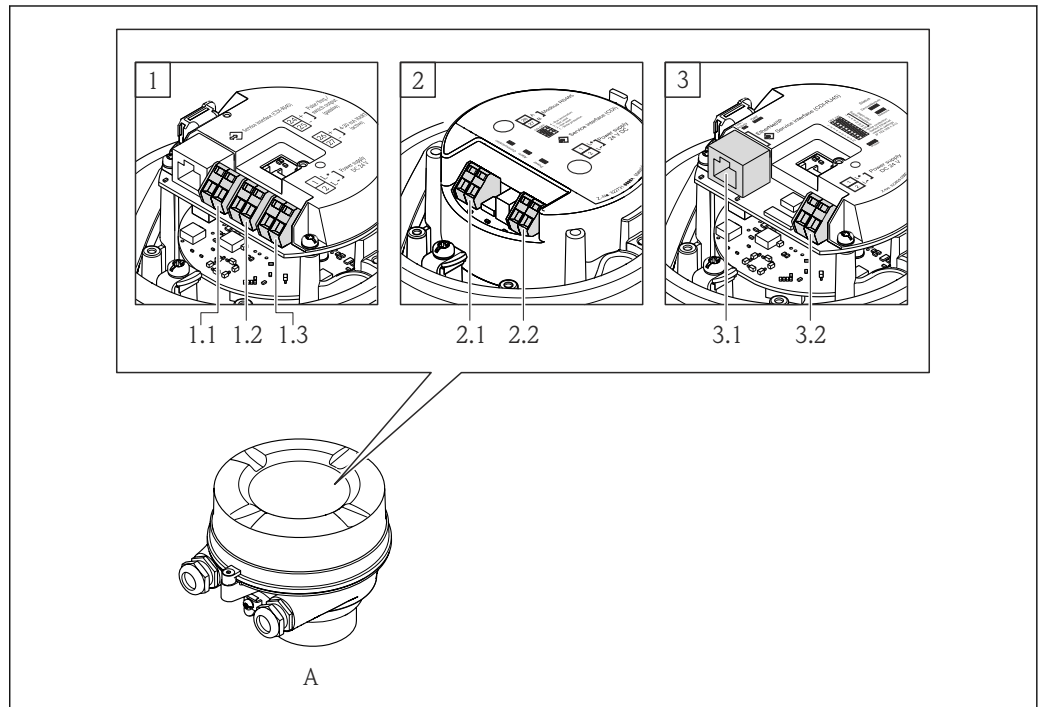

A0019825

- A Housing version: compact, aluminum coated
- 1 Connection version: 4-20 mA HART, pulse/frequency/switch output
 - 1.1 Signal transmission: pulse/frequency/switch output
 - 1.2 Signal transmission: 4-20 mA HART
 - 1.3 Supply voltage
- 2 Connection version: Modbus RS485, PROFIBUS DP
 - 2.1 Signal transmission
 - 2.2 Supply voltage
- 3 Connection version: EtherNet/IP
 - 3.1 Signal transmission
 - 3.2 Supply voltage

Transmitter

Connection version 4-20 mA HART with pulse/frequency/switch output

Order code for "Output", option **B**

Depending on the housing version, the transmitters can be ordered with terminals or device plugs.

Order code for "Housing"	Connection methods available		Possible options for order code "Electrical connection"
	Outputs	Power supply	
Option A	Terminals	Terminals	<ul style="list-style-type: none"> ▪ Option A: coupling M20x1 ▪ Option B: thread M20x1 ▪ Option C: thread G 1/2" ▪ Option D: thread NPT 1/2"
Option A	Device plug	Terminals	<ul style="list-style-type: none"> ▪ Option L: plug M12x1 + thread NPT 1/2" ▪ Option N: plug M12x1 + coupling M20 ▪ Option P: plug M12x1 + thread G 1/2" ▪ Option U: plug M12x1 + thread M20

Order code for "Housing"	Connection methods available		Possible options for order code "Electrical connection"
	Outputs	Power supply	
Option A	Device plug	Device plug	Option Q: 2 x plug M12x1
Order code for "Housing": Option A: compact, coated aluminum			

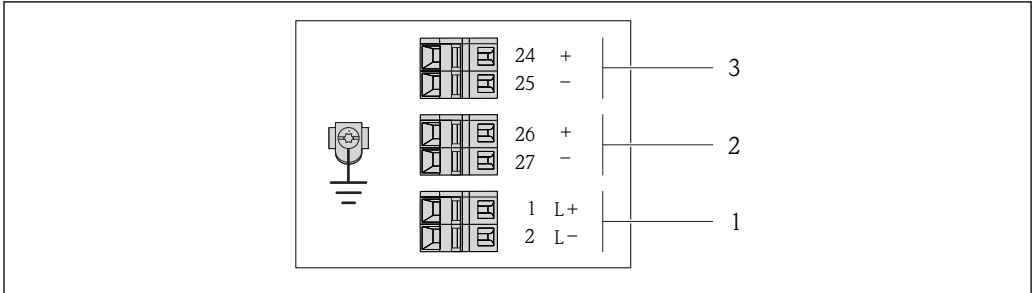

A0016886

- 2 Terminal assignment 4-20 mA HART with pulse/frequency/switch output
- 1 Power supply: DC 24 V
- 2 Output 1: 4-20 mA HART (active)
- 3 Output 2: pulse/frequency/switch output (passive)

Order code for "Output"	Terminal number					
	Power supply		Output 1		Output 2	
	2 (L-)	1 (L+)	27 (-)	26 (+)	25 (-)	24 (+)
Option B	DC 24 V		4-20 mA HART (active)		Pulse/frequency/switch output (passive)	
Order code for "Output": Option B: 4-20 mA HART with pulse/frequency/switch output						

PROFIBUS DP connection version

 For use in the non-hazardous area and Zone 2/Div. 2.

Order code for "Output", option **L**

Depending on the housing version, the transmitters can be ordered with terminals or device plugs.

Order code for "Housing"	Connection methods available		Possible options for order code "Electrical connection"
	Output	Power supply	
Option A	Terminals	Terminals	<ul style="list-style-type: none"> ▪ Option A: coupling M20x1 ▪ Option B: thread M20x1 ▪ Option C: thread G ½" ▪ Option D: thread NPT ½"
Option A	Device plug	Terminals	<ul style="list-style-type: none"> ▪ Option L: plug M12x1 + thread NPT ½" ▪ Option N: plug M12x1 + coupling M20 ▪ Option P: plug M12x1 + thread G ½" ▪ Option U: plug M12x1 + thread M20
Option A	Device plug	Device plug	Option Q : 2 x plug M12x1

Order code for "Housing":
Option **A**: compact, coated aluminum

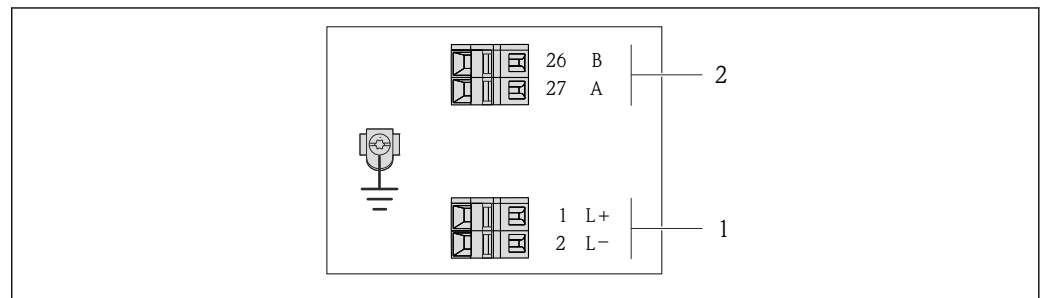

A0022716

 3 *PROFIBUS DP terminal assignment*

- 1 Power supply: DC 24 V
- 2 PROFIBUS DP

Order code for "Output"	Terminal number			
	Power supply		Output	
	2 (L-)	1 (L+)	26 (Rx/D/TxD-P)	27 (Rx/D/TxD-N)
Option L	DC 24 V		B	A

Order code for "Output":
Option **L**: PROFIBUS DP, for use in non-hazardous areas and Zone 2/div. 2

Modbus RS485 connection version

Order code for "Output", option **M**

Depending on the housing version, the transmitters can be ordered with terminals or device plugs.

Order code for "Housing"	Connection methods available		Possible options for order code "Electrical connection"
	Output	Power supply	
Option A	Terminals	Terminals	<ul style="list-style-type: none"> ■ Option A: coupling M20x1 ■ Option B: thread M20x1 ■ Option C: thread G ½" ■ Option D: thread NPT ½"
Option A	Device plug	Terminals	<ul style="list-style-type: none"> ■ Option L: plug M12x1 + thread NPT ½" ■ Option N: plug M12x1 + coupling M20 ■ Option P: plug M12x1 + thread G ½" ■ Option U: plug M12x1 + thread M20
Option A	Device plug	Device plug	Option Q : 2 x plug M12x1

Order code for "Housing":
Option **A**: compact, coated aluminum

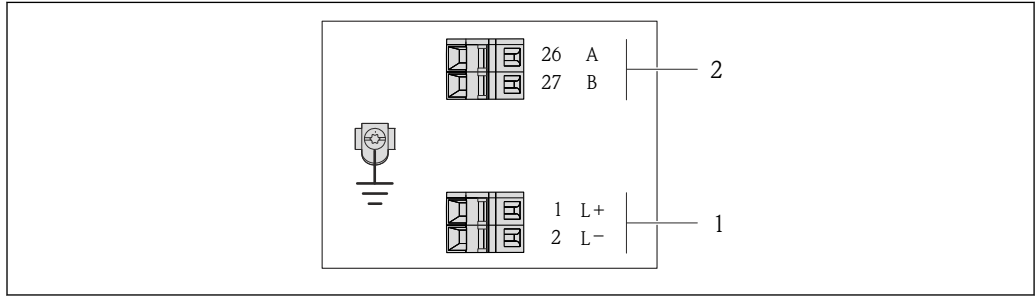

A0019528

4 Modbus RS485 terminal assignment

- 1 Power supply: DC 24 V
- 2 Modbus RS485

Order code for "Output"	Terminal number			
	Power supply		Output	
	2 (L-)	1 (L+)	27 (B)	26 (A)
Option M	DC 24 V		Modbus RS485	

Order code for "Output":
Option **M**: Modbus RS485

EtherNet/IP connection version

Order code for "Output", option **N**

Depending on the housing version, the transmitters can be ordered with terminals or device plugs.

Order code for "Housing"	Connection methods available		Possible options for order code "Electrical connection"
	Output	Power supply	
Option A	Device plug	Terminals	<ul style="list-style-type: none"> ▪ Option L: plug M12x1 + thread NPT 1/2" ▪ Option N: plug M12x1 + coupling M20 ▪ Option P: plug M12x1 + thread G 1/2" ▪ Option U: plug M12x1 + thread M20
Option A	Device plug	Device plug	Option Q : 2 x plug M12x1

Order code for "Housing":
Option **A**: compact, coated aluminum

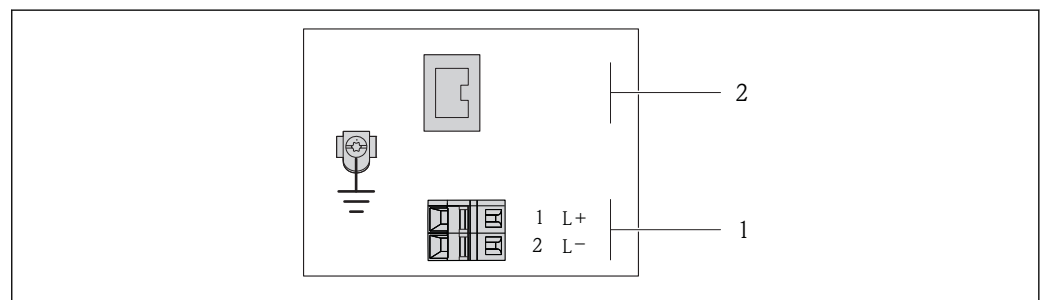

5 EtherNet/IP terminal assignment

- 1 Power supply: DC 24 V
- 2 EtherNet/IP

Order code for "Output"	Terminal number		Output Device plug M12x1
	Power supply 2 (L-)	1 (L+)	
Option N	DC 24 V		EtherNet/IP

Order code for "Output":
Option **N**: EtherNet/IP

Pin assignment, device plug

- i** Order codes for the M12x1 connectors, see the "Order code for **electrical connection**" column:
- 4-20 mA HART, pulse/frequency/switch output (→ 17)
 - PROFIBUS-DP (→ 19)
 - Modbus RS485 (→ 20)
 - EtherNet/IP (→ 21)

Supply voltage

For all connection versions (device side)

Pin	Assignment	Coding	Plug/socket
1	L+	A	Plug
2			
3			
4	L-		
5	Grounding/shielding		

- i** The following is recommended as a socket:
- Binder, series 763, part no. 79 3440 35 05
 - Alternatively: Phoenix part no. 1669767 SAC-5P-M12MS
 - With the order code for "Output", option **B**: 4-20 mA HART, pulse/frequency/switch output
 - With the order code for "Output", option **N**: EtherNet/IP
 - When using the device in a hazardous location: Use a suitably certified socket.

4-20 mA HART with pulse/frequency/switch output

Device plug for signal transmission (device side)

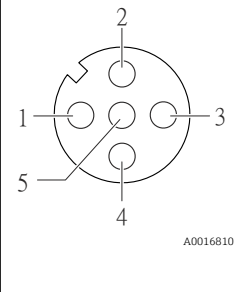
	Pin	Assignment	Coding	Plug/socket
	1	+		
2	-	4-20 mA HART (active)	A	Socket
3	+	Pulse/frequency/switch output (passive)		
4	-	Pulse/frequency/switch output (passive)		
5		Grounding/shielding		

- i**
- Recommended plug: Binder, series 763, part no. 79 3439 12 05
 - When using the device in a hazardous location: Use a suitably certified plug.

PROFIBUS DP

- i** For use in the non-hazardous area and Zone 2/Div. 2.

Device plug for signal transmission (device side)

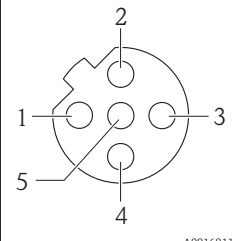
	Pin	Assignment	Coding	Plug/socket
	1			
2	A	PROFIBUS DP		
3				
4	B	PROFIBUS DP		
5		Grounding/shielding		

- i**
- Recommended plug: Binder, series 763, part no. 79 4449 20 05
 - When using the device in a hazardous location: Use a suitably certified plug.

MODBUS RS485

Device plug for signal transmission (device side)

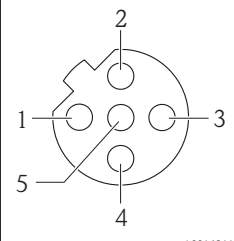
	Pin	Assignment	Coding	Plug/socket
	1			
2	A	Modbus RS485		
3				
4	B	Modbus RS485		
5		Grounding/shielding		

- i**
- Recommended plug: Binder, series 763, part no. 79 4449 20 05
 - When using the device in a hazardous location: Use a suitably certified plug.

EtherNet/IP

Device plug for signal transmission (device side)

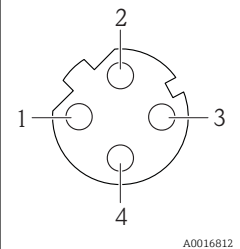
	Pin	Assignment	Coding	Plug/socket	
	1	+	Tx	D	Socket
	2	+	Rx		
	3	-	Tx		
4	-	Rx			



Recommended plug:

- Binder, series 763, part no. 99 3729 810 04
- Phoenix, part no. 1543223 SACC-M12MSD-4Q
- When using the device in a hazardous location: Use a suitably certified plug.

Supply voltage

Transmitter

For device version with all communication types: DC 20 to 30 V

The power unit must be tested to ensure it meets safety requirements (e.g. PELV, SELV).

Power consumption

Transmitter

Order code for "Output"	Maximum Power consumption
Option B : 4-20mA HART, pulse/frequency/switch output	3.5 W
Option L : PROFIBUS DP	3.5 W
Option M : Modbus RS485	3.5 W
Option N : EtherNet/IP	3.5 W

Current consumption

Transmitter

Order code for "Output"	Maximum Current consumption	Maximum switch-on current
Option B : 4-20mA HART, pul./freq./switch output	145 mA	18 A (<0.125 ms)
Option L : PROFIBUS DP	145 mA	18 A (<0.125 ms)
Option M : Modbus RS485	90 mA	10 A (<0.8 ms)
Option N : EtherNet/IP	145 mA	18 A (<0.125 ms)

Power supply failure

- Totalizers stop at the last value measured.
- Depending on the device version, the configuration is retained in the device memory or in the plug-in memory (HistoROM DAT).
- Error messages (incl. total operated hours) are stored.

Electrical connection

Connecting the transmitter

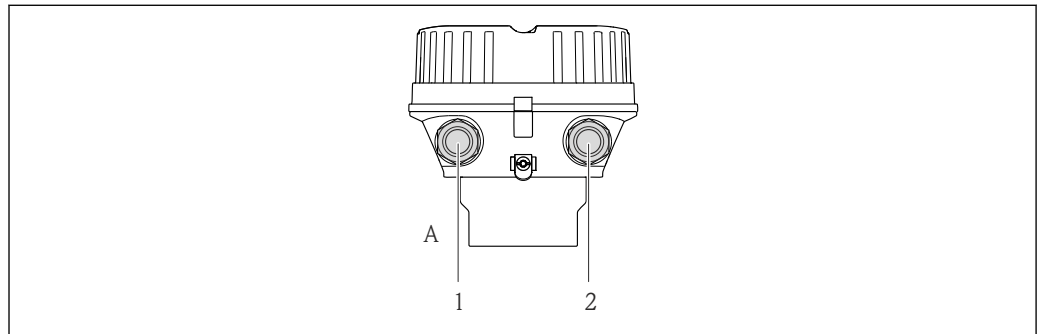

A0019824

- A Housing version: compact, aluminum coated
 1 Cable entry or device plug for signal transmission
 2 Cable entry or device plug for supply voltage



- Terminal assignment (→ 17)
- Pin assignment, device plug (→ 21)



- In the case of device versions with a connector, the transmitter housing does not need to be opened to connect the signal cable or power supply cable.

Connection examples

Current output 4-20 mA HART

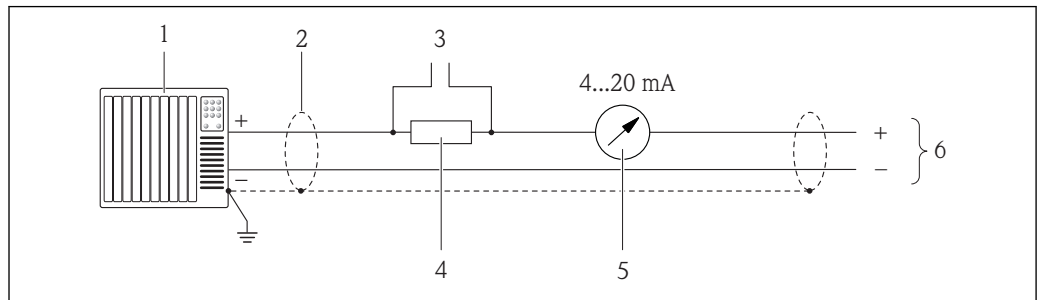

A0016800

6 Connection example for 4-20 mA HART current output (active)

- 1 Automation system with current input (e.g. PLC)
- 2 Cable shield, observe cable specifications (→ 28)
- 3 Connection for HART operating devices (→ 46)
- 4 Resistor for HART communication ($\geq 250 \Omega$): observe maximum load (→ 8)
- 5 Analog display unit: observe maximum load (→ 8)
- 6 Transmitter

Pulse/frequency output

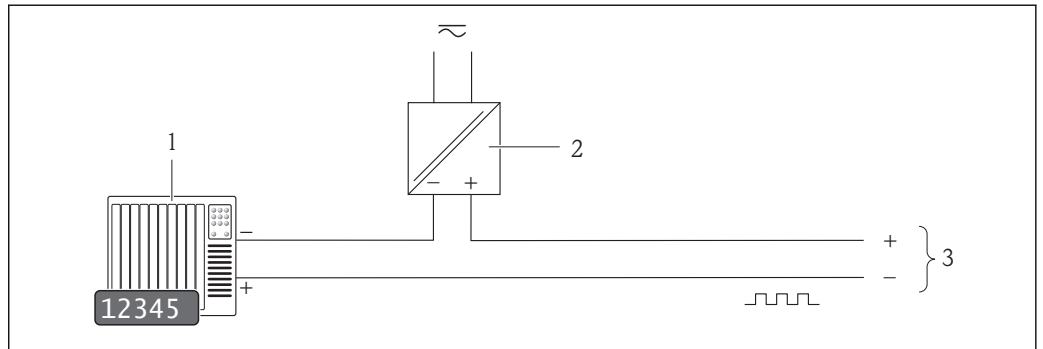

A0016801

7 Connection example for pulse/frequency output (passive)

- 1 Automation system with pulse/frequency input (e.g. PLC)
- 2 Power supply
- 3 Transmitter: observe input values (→ 9)

Switch output

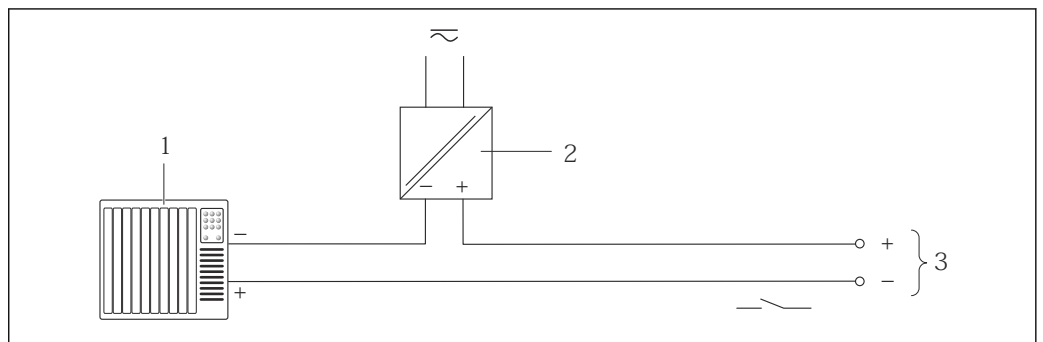

A0016802

8 Connection example for switch output (passive)

- 1 Automation system with switch input (e.g. PLC)
- 2 Power supply
- 3 Transmitter: observe input values (→ 9)

PROFIBUS DP

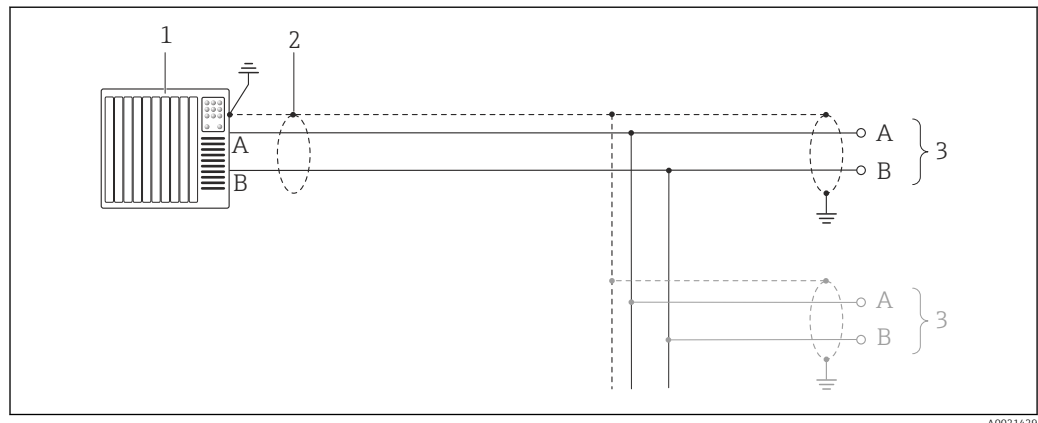

9 Connection example for PROFIBUS DP, non-hazardous area and Zone 2/Div. 2

- 1 Control system (e.g. PLC)
- 2 Cable shield: the cable shield must be grounded at both ends to comply with EMC requirements; observe cable specifications (→ 29)
- 3 Distribution box
- 4 Transmitter

i If baud rates > 1.5 MBaud an EMC cable entry must be used and the cable shield must continue as far as the terminal wherever possible.

Modbus RS485

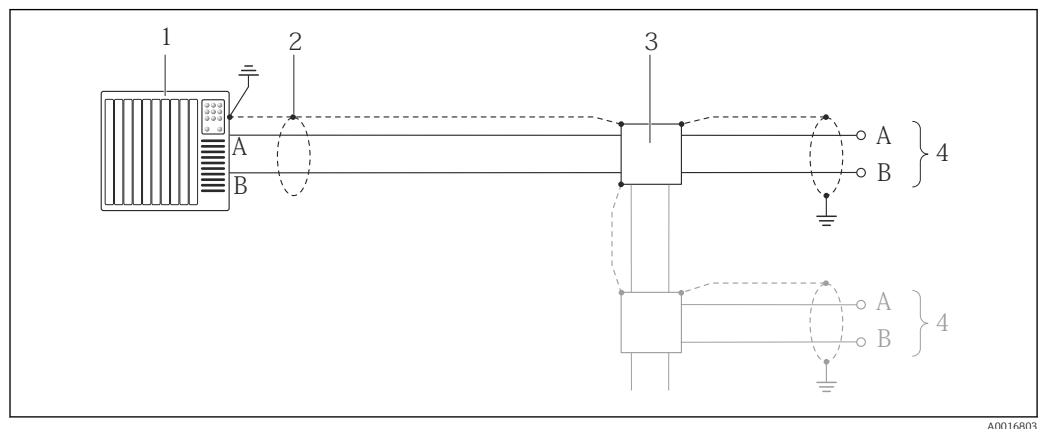

10 Connection example for Modbus RS485, non-hazardous area and Zone 2/Div. 2

- 1 Control system (e.g. PLC)
- 2 Cable shield: the cable shield must be grounded at both ends to comply with EMC requirements; observe cable specifications (→ 29)
- 3 Distribution box
- 4 Transmitter

EtherNet/IP

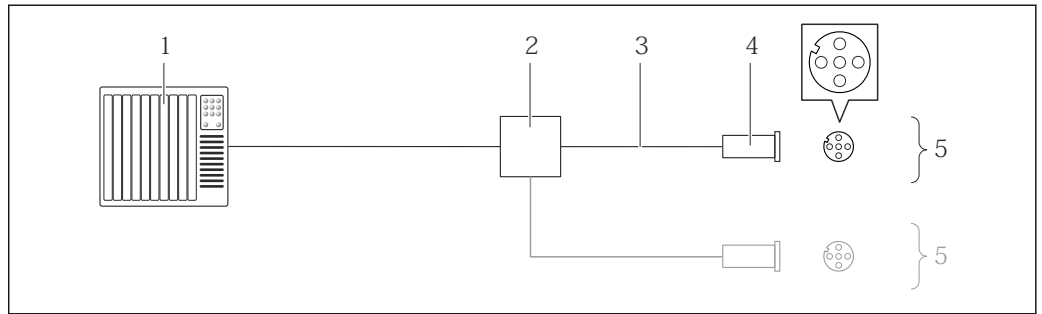

11 Connection example for EtherNet/IP

- 1 Control system (e.g. PLC)
- 2 Ethernet switch
- 3 Observe cable specifications (→ 29)
- 4 Connector
- 5 Transmitter

HART input

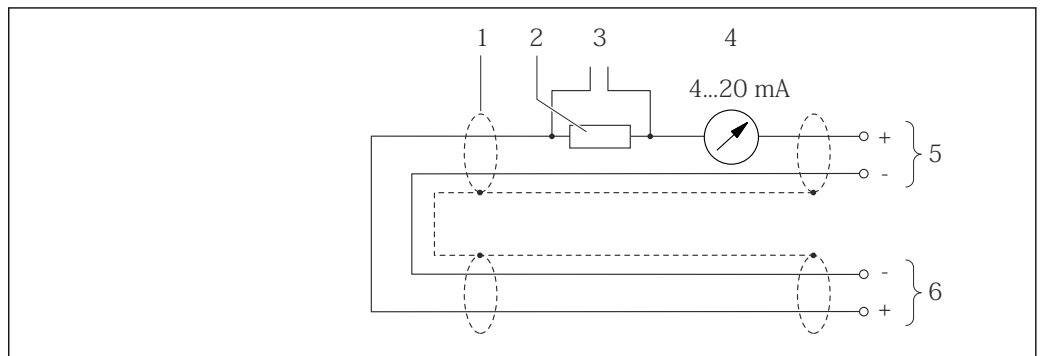

12 Connection example for HART input (burst mode) via current output (active)

- 1 Cable shield, observe cable specifications (→ 28)
- 2 Resistor for HART communication ($\geq 250 \Omega$): observe maximum load (→ 8)
- 3 Connection for HART operating devices (→ 46)
- 4 Analog display unit
- 5 Transmitter
- 6 Sensor for external measured variable

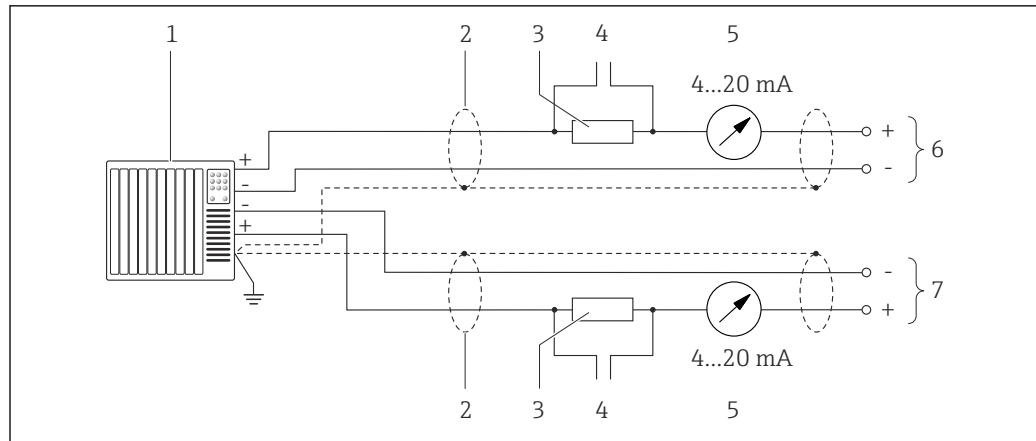

A0019830

13 Connection example for HART input (master mode) via current output (active)

- 1 Automation system with current input (e.g. PLC).
Prerequisite: automation system with HART version 6, HART commands 113 and 114 can be processed.
- 2 Cable shield, observe cable specifications (→ 28)
- 3 Resistor for HART communication ($\geq 250 \Omega$): observe maximum load (→ 8)
- 4 Connection for HART operating devices (→ 46)
- 5 Analog display unit
- 6 Transmitter
- 7 Sensor for external measured variable

Ensuring potential equalization

CAUTION

Electrode damage can result in the complete failure of the device!

- ▶ Make sure that the fluid and sensor have the same electrical potential.
- ▶ Pay attention to internal grounding concepts in the company.
- ▶ Pay attention to the pipe material or grounding.

Connection examples for standard situations

Connection example in special situations

Terminals

Transmitter

Spring terminals for wire cross-sections 0.5 to 2.5 mm^2 (20 to 14 AWG)

Cable entries

- Cable gland: $M20 \times 1.5$ with cable $\phi 6$ to 12 mm (0.24 to 0.47 in)
- Thread for cable entry:
 - NPT $\frac{1}{2}$ "
 - G $\frac{1}{2}$ "
 - M20

Cable specification

Permitted temperature range

- $-40 \text{ }^\circ\text{C}$ ($-40 \text{ }^\circ\text{F}$) to $+80 \text{ }^\circ\text{C}$ ($+176 \text{ }^\circ\text{F}$)
- Minimum requirement: cable temperature range \geq ambient temperature $+20 \text{ K}$

Power supply cable

Standard installation cable is sufficient.

Signal cable

Current output

For 4-20 mA HART: Shielded cable recommended. Observe grounding concept of the plant.

Pulse/frequency/switch output

Standard installation cable is sufficient.

PROFIBUS DP

The IEC 61158 standard specifies two types of cable (A and B) for the bus line which can be used for every transmission rate. Cable type A is recommended.

Cable type	A
Characteristic impedance	135 to 165 Ω at a measuring frequency of 3 to 20 MHz
Cable capacitance	<30 pF/m
Wire cross-section	>0.34 mm ² (22 AWG)
Cable type	Twisted pairs
Loop resistance	≤110 Ω /km
Signal damping	Max. 9 dB over the entire length of the cable cross-section
Shielding	Copper braided shielding or braided shielding with foil shield. When grounding the cable shield, observe the grounding concept of the plant.

Modbus RS485

The EIA/TIA-485 standard specifies two types of cable (A and B) for the bus line which can be used for every transmission rate. Cable type A is recommended.

Cable type	A
Characteristic impedance	135 to 165 Ω at a measuring frequency of 3 to 20 MHz
Cable capacitance	<30 pF/m
Wire cross-section	>0.34 mm ² (22 AWG)
Cable type	Twisted pairs
Loop resistance	≤110 Ω /km
Signal damping	Max. 9 dB over the entire length of the cable cross-section
Shielding	Copper braided shielding or braided shielding with foil shield. When grounding the cable shield, observe the grounding concept of the plant.

EtherNet/IP

The standard ANSI/TIA/EIA-568-B.2 Annex specifies CAT 5 as the minimum category for a cable used for EtherNet/IP. CAT 5e and CAT 6 are recommended.

 For more information on planning and installing EtherNet/IP networks, please refer to the "Media Planning and Installation Manual. EtherNet/IP" of the ODVA Organization.

Performance characteristics



Reference operating conditions

In accordance with DIN EN 29104

- Fluid temperature: +28±2 °C (+82±4 °F)
- Ambient temperature range: +22±2 °C (+72±4 °F)
- Warm-up period: 30 min

Installation

- Inlet run > 10 × DN
- Outlet run > 5 × DN
- Sensor and transmitter grounded.
- The sensor is centered in the pipe.

 To calculate the measuring range, use the *Applicator* sizing tool (→  53)

Maximum measured error

Error limits under reference operating conditions

o.r. = of reading

Volume flow

- ±0.5 % o.r. ± 1 mm/s (0.04 in/s)
- Optional: ±0.2 % o.r. ± 2 mm/s (0.08 in/s)

i Fluctuations in the supply voltage do not have any effect within the specified range.

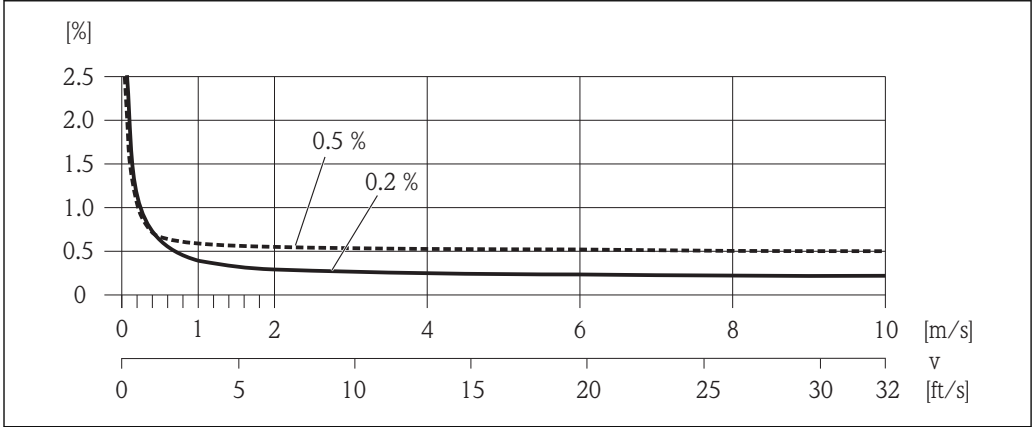

14 Maximum measured error in % o.r.

Electrical conductivity

Max. measured error not specified.

Accuracy of outputs

o.r. = of reading; o.f.s. = of full scale value

i The output accuracy must be factored into the measured error if analog outputs are used, but can be ignored for fieldbus outputs (e.g. Modbus RS485, EtherNet/IP).

Current output

Accuracy	Max. ±0.05 % o.f.s. or ±5 µA
-----------------	------------------------------

Pulse/frequency output

Accuracy	Max. ±50 ppm o.r.
-----------------	-------------------

Repeatability

o.r. = of reading

Volume flow

Max. ±0.1 % o.r. ± 0.5 mm/s (0.02 in/s)

Electrical conductivity

Max. ±5 % o.r.

Temperature measurement response time

T₉₀ < 15 s

Influence of ambient temperature

o.r. = of reading; o.f.s. = of full scale value

Current output

Temperature coefficient	Max. ±50 ppm/°C o.f.s. or ±1 µA/°C
--------------------------------	------------------------------------

Pulse/frequency output

Temperature coefficient	Max. ± 50 ppm o.r. /100 °C
--------------------------------	--------------------------------

Installation

No special measures such as supports are necessary. External forces are absorbed by the construction of the device.

Mounting location

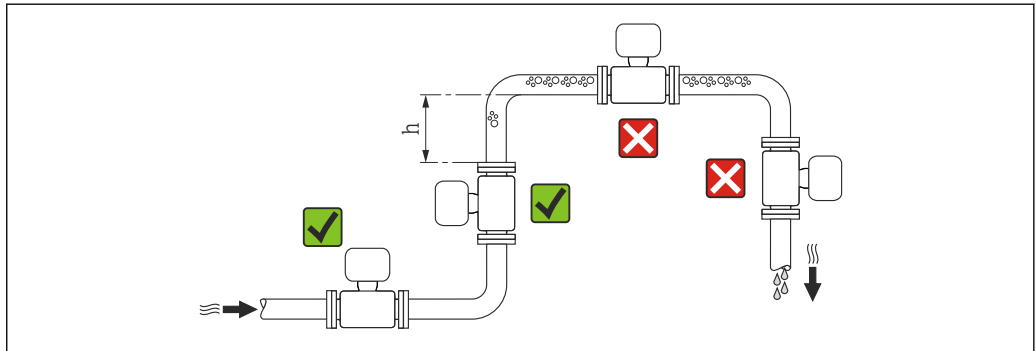

A0023343

Preferably install the sensor in an ascending pipe, and ensure a sufficient distance to the next pipe elbow: $h \geq 2 \times DN$

To prevent measuring errors arising from accumulation of gas bubbles in the measuring tube, avoid the following mounting locations in the pipe:

- Highest point of a pipeline.
- Directly upstream of a free pipe outlet in a down pipe.

Installation in down pipes

Install a siphon with a vent valve downstream of the sensor in down pipes whose length $h \geq 5$ m (16.4 ft). This precaution is to avoid low pressure and the consequent risk of damage to the measuring tube. This measure also prevents the system losing prime.

 For information on the liner's resistance to partial vacuum (\rightarrow  36)

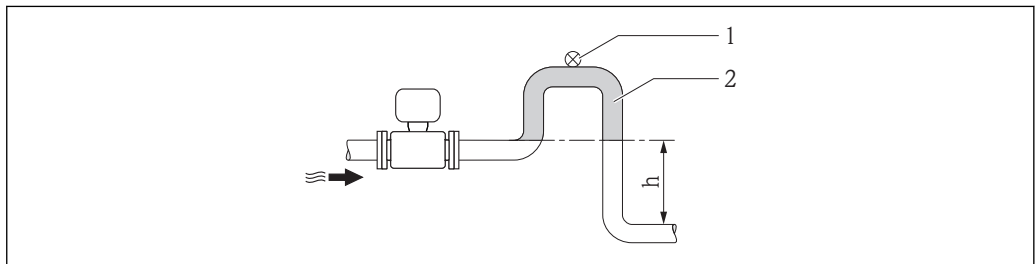

A0017064

 15 Installation in a down pipe

- 1 Vent valve
- 2 Pipe siphon
- h Length of down pipe

Installation in partially filled pipes

A partially filled pipe with a gradient necessitates a drain-type configuration. The empty pipe detection (EPD) function offers additional protection by detecting empty or partially filled pipes.

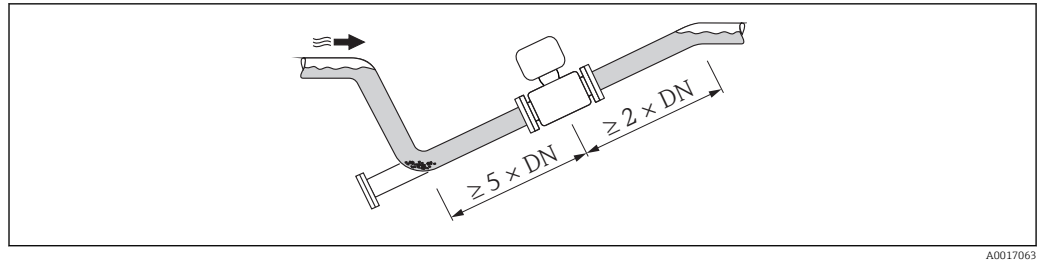

A0017063

Orientation

The direction of the arrow on the sensor nameplate helps you to install the sensor according to the flow direction (direction of medium flow through the piping).

An optimum orientation position helps avoid gas and air accumulations and deposits in the measuring tube.

The measuring device also offers the empty pipe detection function to detect partially filled measuring pipes in the event of outgassing fluids or variable process pressures.

Vertical

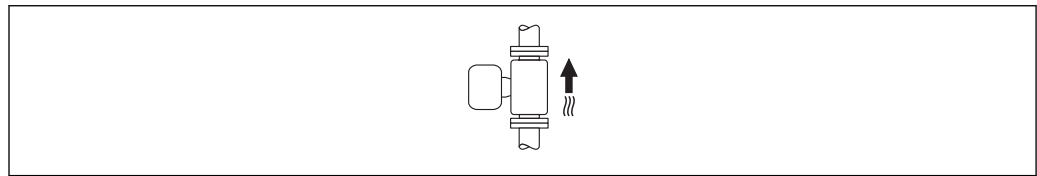

A0015591

This is the optimum for self-emptying piping systems and for use in conjunction with empty pipe detection.

Horizontal

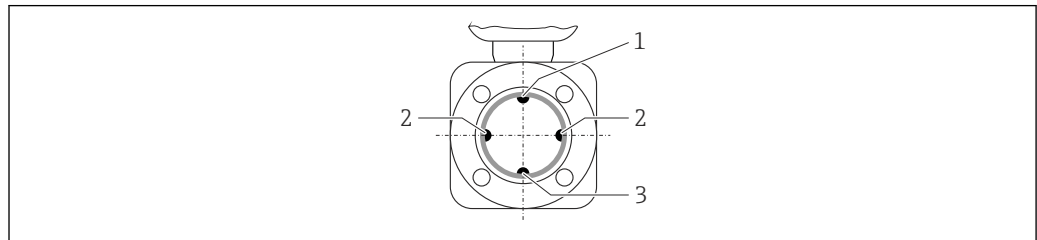

A0016260

- 1 EPD electrode for empty pipe detection
- 2 Measuring electrodes for signal detection
- 3 Reference electrode for potential equalization

- i** The measuring electrode plane must be horizontal. This prevents brief insulation of the two measuring electrodes by entrained air bubbles.
- The empty pipe detection only works if the transmitter housing is pointing upwards as otherwise there is no guarantee that the empty pipe detection function will actually respond to a partially filled or empty measuring tube.

Inlet and outlet runs

If possible, install the sensor upstream from fittings such as valves, T-pieces or elbows.

Observe the following inlet and outlet runs to comply with accuracy specifications:

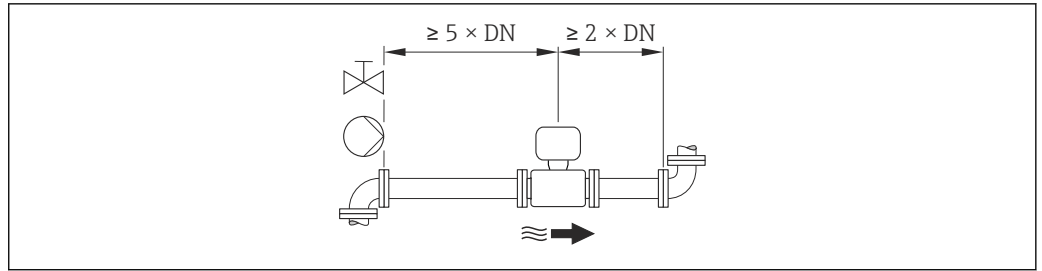

A0016275

Adapters

Suitable adapters to DIN EN 545 (double-flange reducers) can be used to install the sensor in larger-diameter pipes. The resultant increase in the rate of flow improves measuring accuracy with very slow-moving fluids.

The nomogram shown here can be used to calculate the pressure loss caused by reducers and expanders:

- Calculate the ratio of the diameters d/D .
- From the nomogram read off the pressure loss as a function of flow velocity (downstream from the reduction) and the d/D ratio.

i The nomogram only applies to liquids with a viscosity similar to that of water.

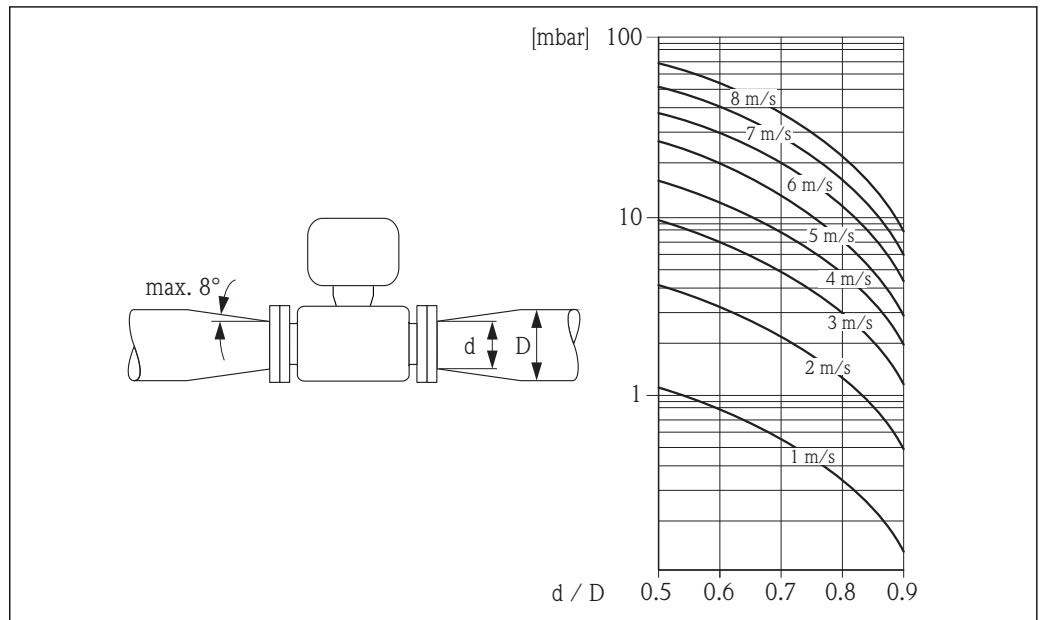

A0016359

Environment

Ambient temperature range	Transmitter	-40 to +60 °C (-40 to +140 °F)
	Sensor	Process connection material, carbon steel: -10 to +60 °C (+14 to +140 °F)
	Liner	Do not exceed or fall below the permitted temperature range of the liner (→ 35).

If operating outdoors:

- Install the measuring device in a shady location.
- Avoid direct sunlight, particularly in warm climatic regions.
- Avoid direct exposure to weather conditions.

Temperature tables

The following interdependencies between the permitted ambient and fluid temperatures apply when operating the device in hazardous areas:

Ex nA, cCSA_{US} NI

SI units

T _a [°C]	T6 [85 °C]	T5 [100 °C]	T4 [135 °C]	T3 [200 °C]	T2 [300 °C]	T1 [450 °C]
30	50	95	130	150	150	150
50	-	95	130	150	150	150
60	-	95	110	110	110	110

US units

T _a [°F]	T6 [185 °F]	T5 [212 °F]	T4 [275 °F]	T3 [392 °F]	T2 [572 °F]	T1 [842 °F]
86	122	203	266	302	302	302
122	-	203	266	302	302	302
140	-	203	230	230	230	230

Storage temperature

The storage temperature corresponds to the operating temperature range of the measuring transmitter and the appropriate measuring sensors.

- Protect the measuring device against direct sunlight during storage in order to avoid unacceptably high surface temperatures.
- Select a storage location where moisture cannot collect in the measuring device as fungus or bacteria infestation can damage the liner.
- If protection caps or protective covers are mounted these should never be removed before installing the measuring device.

Degree of protection**Transmitter and sensor**

- As standard: IP66/67, type 4X enclosure
- When housing is open: IP20, type 1 enclosure
- Display module: IP20, type 1 enclosure

Shock resistance

As per IEC/EN 60068-2-31

Vibration resistance

Acceleration up to 2 g following IEC 60068-2-6

Mechanical load

- Protect the transmitter housing against mechanical effects, such as shock or impact.
- Never use the transmitter housing as a ladder or climbing aid.

Electromagnetic compatibility (EMC)

- As per IEC/EN 61326 and NAMUR Recommendation 21 (NE 21)
- Complies with emission limits for industry as per EN 55011 (Class A)
- Device version with PROFIBUS DP: Complies with emission limits for industry as per EN 50170 Volume 2, IEC 61784



The following applies for PROFIBUS DP: If baud rates > 1.5 MBaud an EMC cable entry must be used and the cable shield must continue as far as the terminal wherever possible.



For details refer to the Declaration of Conformity.

Process

Medium temperature range

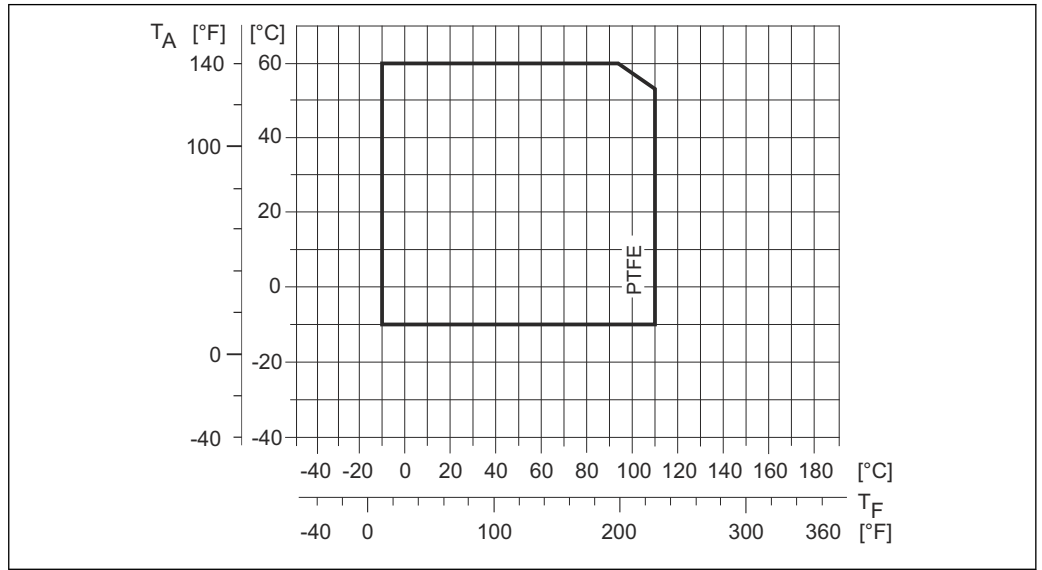

T_A Ambient temperature

T_F Medium temperature

Conductivity

$\geq 5 \mu\text{S}/\text{cm}$ for liquids in general

Pressure-temperature ratings

The following pressure-temperature ratings refer to the entire device and not just the process connection.

Process connection: flange according to EN 1092-1 (DIN 2501)

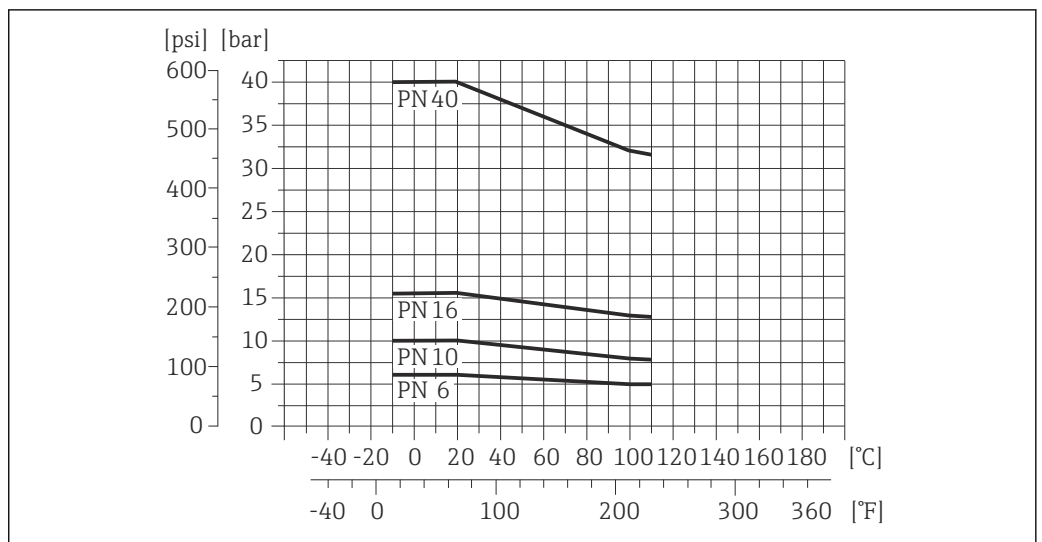

16 Process connection material: carbon steel, FE410WB/S235JRG2

Process connection: flange according to ASME B16.5

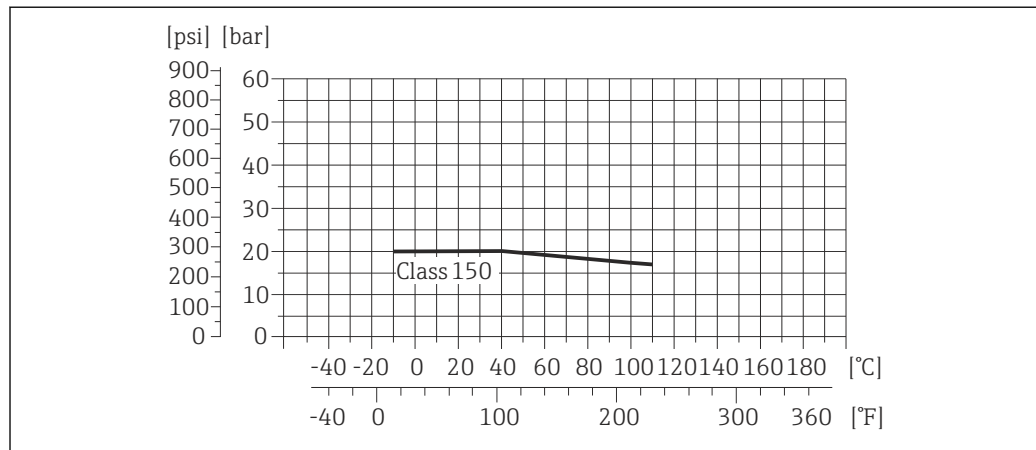

A0022939-EN

17 Process connection material: carbon steel, A105

Process connection: flange according to JIS B2220

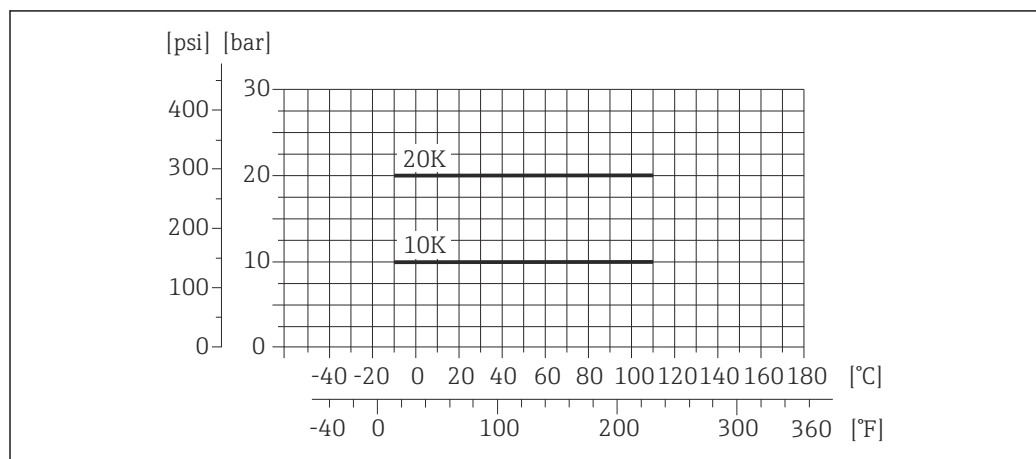

A0022940-EN

18 Process connection material: carbon steel, S235JRG2/HII

Pressure tightness

"-" = no specifications possible

Liner: PTFE

Nominal diameter		Limit values for absolute pressure in [mbar] ([psi]) for fluid temperatures:			
[mm]	[in]	+25 °C (+77 °F)	+80 °C (+176 °F)	+100 °C (+212 °F)	+110 °C (+230 °F)
15	½	0 (0)	0 (0)	0 (0)	100 (1.45)
25	1	0 (0)	0 (0)	0 (0)	100 (1.45)
32	-	0 (0)	0 (0)	0 (0)	100 (1.45)
40	1 ½	0 (0)	0 (0)	0 (0)	100 (1.45)
50	2	0 (0)	0 (0)	0 (0)	100 (1.45)
65	-	0 (0)	-	40 (0.58)	130 (1.89)
80	3	0 (0)	-	40 (0.58)	130 (1.89)
100	4	0 (0)	-	135 (1.96)	170 (2.47)
125	-	135 (1.96)	-	240 (3.48)	385 (5.58)
150	6	135 (1.96)	-	240 (3.48)	385 (5.58)

Nominal diameter		Limit values for absolute pressure in [mbar] ([psi]) for fluid temperatures:			
[mm]	[in]	+25 °C (+77 °F)	+80 °C (+176 °F)	+100 °C (+212 °F)	+110 °C (+230 °F)
200	8	200 (2.90)	–	290 (4.21)	410 (5.95)
250	10	330 (4.79)	–	400 (5.80)	530 (7.69)
300	12	400 (5.80)	–	500 (7.25)	630 (9.14)
350	14	470 (6.82)	–	600 (8.70)	730 (10.6)
400	16	540 (7.83)	–	670 (9.72)	800 (11.6)
450	18	No negative pressure permitted!			
500	20				
600	24				

Flow limit

The diameter of the pipe and the flow rate determine the nominal diameter of the sensor. The optimum velocity of flow is between 2 to 3 m/s (6.56 to 9.84 ft/s). Also match the velocity of flow (v) to the physical properties of the fluid:

- v < 2 m/s (6.56 ft/s): for abrasive fluids (e.g. potter's clay, lime milk, ore slurry)
- v > 2 m/s (6.56 ft/s): for fluids producing buildup (e.g. wastewater sludges)

i A necessary increase in the flow velocity can be achieved by reducing the sensor nominal diameter.

i For an overview of the measuring range full scale values, see the "Measuring range" section (→ 6)

Pressure loss

- No pressure loss occurs if the sensor is installed in a pipe with the same nominal diameter.
- Pressure losses for configurations incorporating adapters according to DIN EN 545 (→ 33)

System pressure

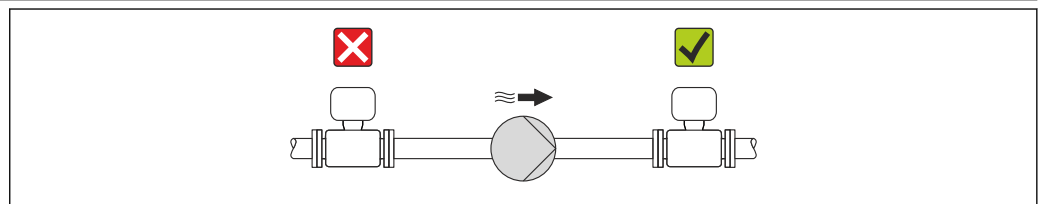

A0015594

Never install the sensor on the pump suction side in order to avoid the risk of low pressure, and thus damage to the liner.

i Furthermore, install pulse dampers if reciprocating, diaphragm or peristaltic pumps are used.

- For information on the liner's resistance to partial vacuum (→ 36)
- Information on the shock resistance of the measuring system (→ 34)
- Information on the vibration resistance of the measuring system (→ 34)

Vibrations

In the event of very strong vibrations, the pipe and sensor must be supported and fixed.

i Information on the shock resistance of the measuring system (→ 34)
 Information on the vibration resistance of the measuring system (→ 34)

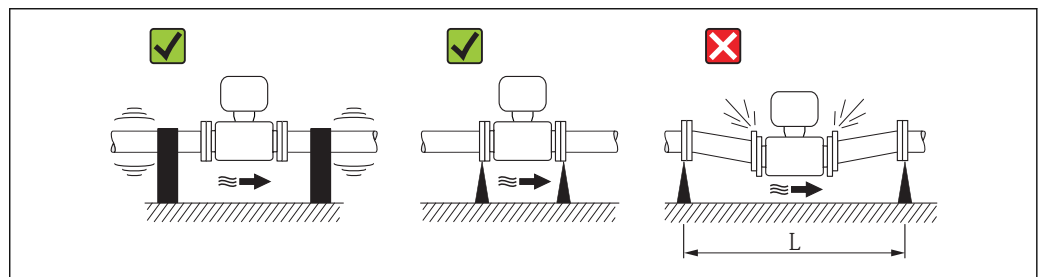

A0016266

19 Measures to avoid device vibrations (L > 10 m (33 ft))

Mechanical construction

Design, dimensions

Compact version

Order code for "Housing", option A "Compact, coated aluminum" with DN 15 to 300 (½ to 12")

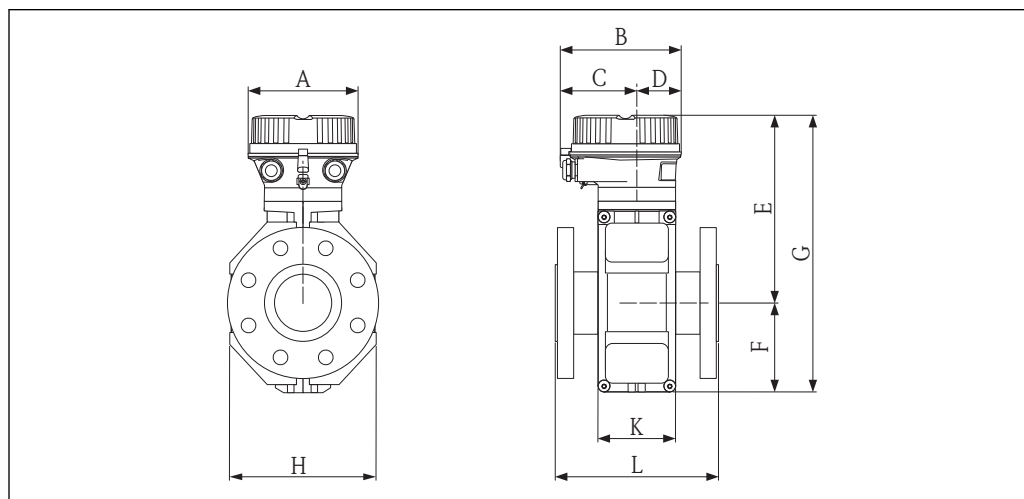

A0019491

Dimensions in SI units

DN	L ¹⁾	A	B	C	D	E	F	G	H	K
[mm]	[mm]	[mm]	[mm]	[mm]	[mm]	[mm]	[mm]	[mm]	[mm]	[mm]
15	200	136	147.5	93.5	54	197	84	281	120	94
25	200	136	147.5	93.5	54	197	84	281	120	94
32	200	136	147.5	93.5	54	197	84	281	120	94
40	200	136	147.5	93.5	54	197	84	281	120	94
50	200	136	147.5	93.5	54	197	84	281	120	94
65	200	136	147.5	93.5	54	222	109	331	180	94
80	200	136	147.5	93.5	54	222	109	331	180	94
100	250	136	147.5	93.5	54	222	109	331	180	94
125	250	136	147.5	93.5	54	262	150	412	260	140
150	300	136	147.5	93.5	54	262	150	412	260	140
200	350	136	147.5	93.5	54	287	180	467	324	156
250	450	136	147.5	93.5	54	312	205	517	400	166
300	500	136	147.5	93.5	54	337	230	567	460	166

1) The length (L) is always the same and does not depend on the selected pressure rating.

Dimensions in US units

DN	L ¹⁾	A	B	C	D	E	F	G	H	K
[in]	[in]	[in]	[in]	[in]	[in]	[in]	[in]	[in]	[in]	[in]
½	7.87	5.35	5.81	3.68	2.13	7.76	3.31	11.1	4.72	3.70
1	7.87	5.35	5.81	3.68	2.13	7.76	3.31	11.1	4.72	3.70
1 ½	7.87	5.35	5.81	3.68	2.13	7.76	3.31	11.1	4.72	3.70
2	7.87	5.35	5.81	3.68	2.13	7.76	3.31	11.1	4.72	3.70

DN	L ¹⁾	A	B	C	D	E	F	G	H	K
[in]	[in]	[in]	[in]	[in]	[in]	[in]	[in]	[in]	[in]	[in]
3	7.87	5.35	5.81	3.68	2.13	8.74	4.29	13.0	7.09	3.70
4	9.84	5.35	5.81	3.68	2.13	8.74	4.29	13.0	7.09	3.70
6	11.8	5.35	5.81	3.68	2.13	10.3	5.91	16.2	10.2	5.51
8	13.8	5.35	5.81	3.68	2.13	11.3	7.09	18.4	12.8	6.14
10	17.7	5.35	5.81	3.68	2.13	12.3	8.07	20.4	15.8	6.54
12	19.7	5.35	5.81	3.68	2.13	13.3	9.06	22.3	18.1	6.54

1) The length (L) is always the same and does not depend on the selected pressure rating.

Order code for "Housing", option A "Compact, coated aluminum" with DN 350 to 600 (14 to 24")

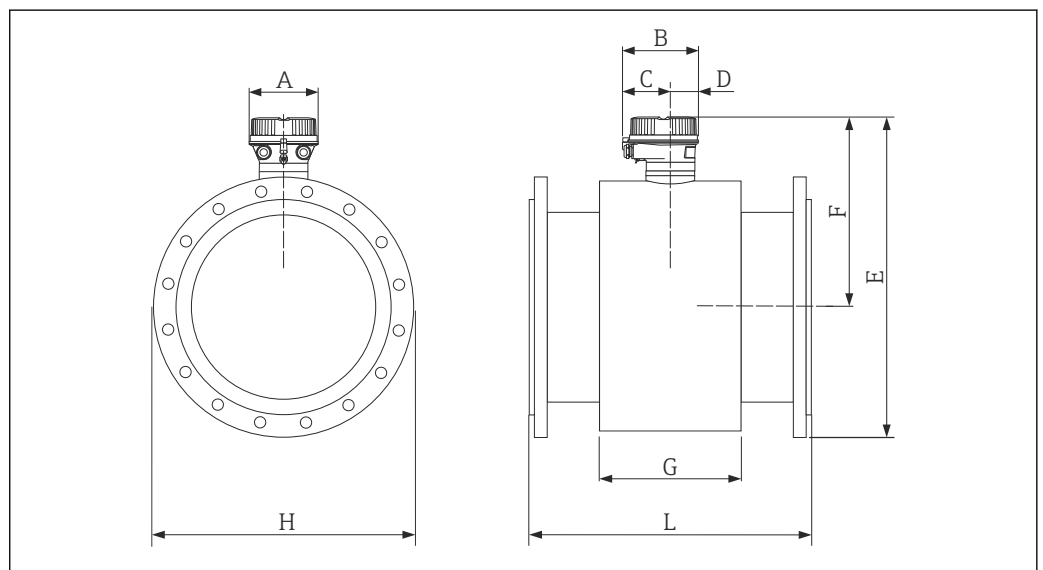

A0023368

Dimensions in SI units

DN	L ¹⁾	A	B	C	D	F	G
[mm]	[mm]	[mm]	[mm]	[mm]	[mm]	[mm]	[mm]
350	550	136	147.5	93.5	54	399	290
400	600	136	147.5	93.5	54	425	290
450	600	136	147.5	93.5	54	450	290
500	600	136	147.5	93.5	54	476	290
600	600	136	147.5	93.5	54	528	290

1) The length (L) is always the same and does not depend on the selected pressure rating.

DN	E for pressure rating				H for pressure rating			
	PN 6	PN 10	PN 16	ASME	PN 6	PN 10	PN 16	ASME
[mm]	[mm]	[mm]	[mm]	[mm]	[mm]	[mm]	[mm]	[mm]
350	644	651	659	665	490	505	520	533
400	695	707	715	723	540	565	580	597
450	747	757	770	767	595	615	640	635

DN [mm]	E for pressure rating				H for pressure rating			
	PN 6 [mm]	PN 10 [mm]	PN 16 [mm]	ASME [mm]	PN 6 [mm]	PN 10 [mm]	PN 16 [mm]	ASME [mm]
500	798	811	833	825	645	670	715	699
600	905	918	948	934	755	780	840	813

Dimensions in US units

DN [in]	L ¹⁾ [in]	A [in]	B [in]	C [in]	D [in]	F [in]	G [in]
14	21.6	5.35	5.81	3.68	2.13	15.7	11.4
16	23.6	5.35	5.81	3.68	2.13	16.7	11.4
18	23.6	5.35	5.81	3.68	2.13	17.7	11.4
20	23.6	5.35	5.81	3.68	2.13	18.7	11.4
24	23.6	5.35	5.81	3.68	2.13	20.8	11.4

1) The length (L) is always the same and does not depend on the selected pressure rating.

DN [in]	E for pressure rating				H for pressure rating			
	PN 6 [in]	PN 10 [in]	PN 16 [in]	ASME [in]	PN 6 [in]	PN 10 [in]	PN 16 [in]	ASME [in]
14	25.4	25.6	25.9	26.2	19.3	19.9	20.5	21.0
16	27.4	27.8	28.2	28.5	21.3	22.2	22.8	23.5
18	29.4	29.8	30.3	30.2	23.4	24.2	25.2	25.0
20	31.4	31.9	32.8	32.5	25.4	26.4	28.2	27.5
24	35.6	36.1	37.3	36.8	29.7	30.7	33.1	32.0

Accessories

Ground disk for flange connection

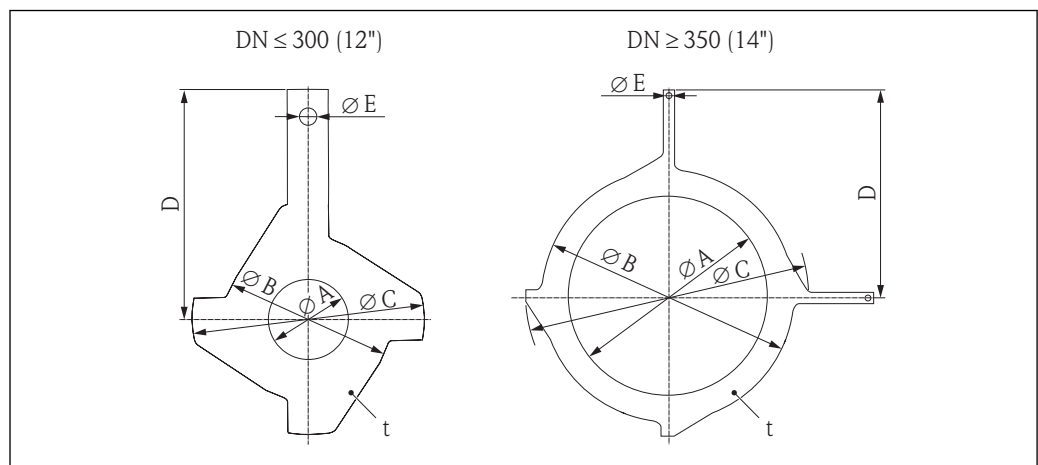

A0003221

Dimensions in SI units

DN ¹⁾ EN (DIN), JIS [mm]	A PTFE [mm]	B [mm]	C [mm]	D [mm]	E [mm]	t [mm]
15	16	43	61.5	73	6.5	2
25	26	62	77.5	87.5	6.5	2
32	35	80	87.5	94.5	6.5	2
40	41	82	101	103	6.5	2
50	52	101	115.5	108	6.5	2
65	68	121	131.5	118	6.5	2
80	80	131	154.5	135	6.5	2
100	104	156	186.5	153	6.5	2
125	130	187	206.5	160	6.5	2
150	158	217	256	184	6.5	2
200	206	267	288	205	6.5	2
250	260	328	359	240	6.5	2
300 ²⁾	312	375	413	273	6.5	2
300 ³⁾	310	375	404	268	6.5	2
350 ²⁾	343	433	479	365	9.0	2
400 ²⁾	393	480	542	395	9.0	2
450 ²⁾	439	538	583	417	9.0	2
500 ²⁾	493	592	650	460	9.0	2
600 ²⁾	593	693	766	522	9.0	2

- 1) Ground disks DN 15 to 250 (½ to 10") can be used for all available flange standards/pressure ratings.
2) PN 10/16
3) JIS 10K/20K

Dimensions in US units

DN ¹⁾ ASME [in]	A PTFE [in]	B [in]	C [in]	D [in]	E [in]	t [in]
½	0.63	1.69	2.42	2.87	0.26	0.08
1	1.02	2.44	3.05	3.44	0.26	0.08
1 ½	1.61	3.23	3.98	4.06	0.26	0.08
2	2.05	3.98	4.55	4.25	0.26	0.08
3	3.15	5.16	6.08	5.31	0.26	0.08
4	4.09	6.14	7.34	6.02	0.26	0.08
6	6.22	8.54	10.08	7.24	0.26	0.08
8	8.11	10.51	11.34	8.07	0.26	0.08
10	10.24	12.91	14.13	9.45	0.26	0.08
12	12.28	14.76	16.26	10.75	0.26	0.08
14	13.50	17.05	18.86	14.37	0.35	0.08
16	15.47	18.90	21.34	15.55	0.35	0.08
18	17.28	21.18	22.95	16.42	0.35	0.08

DN ¹⁾ ASME [in]	A PTFE [in]	B [in]	C [in]	D [in]	E [in]	t [in]
20	19.41	23.31	25.59	18.11	0.35	0.08
24	23.35	27.28	30.16	20.55	0.35	0.08

1) Ground disks can be used for all available pressure ratings.

Weight

Compact version

- Including the transmitter (1.8 kg (4.0 lbs))
- Weight specifications excluding packaging material

Weight in SI units

Nominal diameter		EN (DIN)				ASME	JIS
[mm]	[in]	PN 6 [kg]	PN 10 [kg]	PN 16 [kg]	PN 40 [kg]	Class 150 [kg]	10K [kg]
15	½	-	-	-	4.9	4.9	4.9
25	1	-	-	-	5.7	5.7	5.7
32	-	-	-	-	6.4	-	5.7
40	1 ½	-	-	-	7.8	7.8	6.7
50	2	-	-	-	9.0	9.0	7.7
65	-	-	-	10.4	-	-	9.5
80	3	-	-	12.4	-	12.4	10.9
100	4	-	-	14.4	-	14.4	13.1
125	-	-	-	19.9	-	-	19.4
150	6	-	-	23.9	-	23.9	22.9
200	8	-	43.4	44.4	-	43.4	40.3
250	10	-	63.4	68.4	-	73.4	67.8
300	12	-	68.4	79.4	-	108.4	70.7
350	14	75.8	86.8	97.8	-	135.8	-
400	16	87.8	102.8	118.8	-	166.8	-
450	18	97.8	110.8	131.8	-	189.8	-
500	20	112.8	130.8	180.8	-	226.8	-
600	24	153.8	160.8	258.8	-	300.8	-

Weight in US units

Nominal diameter		ASME
[mm]	[in]	Class 150 [lbs]
15	½	10.8
25	1	12.6
40	1 ½	17.2
50	2	19.9
80	3	27.3
100	4	31.8

Nominal diameter		ASME
[mm]	[in]	Class 150 [lbs]
150	6	52.7
200	8	95.7
250	10	161.9
300	12	239.0
350	14	299.4
400	16	367.8
450	18	418.5
500	20	500.1
600	24	663.3

Measuring tube specification

Nominal diameter		Pressure rating			Process connection internal diameter	
[mm]	[in]	EN (DIN)	ASME	JIS	PTFE	
		[bar]	[psi]	[bar]	[mm]	[in]
15	½	PN 40	Class 150	20K	14	0.55
25	1	PN 40	Class 150	20K	26	1.02
32	-	PN 40	-	20K	34	1.34
40	1 ½	PN 40	Class 150	20K	40	1.57
50	2	PN 40	Class 150	10K	51	2.01
65	-	PN 16	-	10K	67	2.64
80	3	PN 16	Class 150	10K	79	3.11
100	4	PN 16	Class 150	10K	103	4.06
125	-	PN 16	-	10K	128	5.04
150	6	PN 16	Class 150	10K	155	6.10
200	8	PN 10/16	Class 150	10K	203	7.99
250	10	PN 10	-	10K	257	10.1
250	10	PN 16	Class 150	10K	255	10.0
300	12	PN 16	Class 150	10K	302	11.9
350	14	PN 6/10	-	-	338	13.3
350	14	PN 16	Class 150	-	336	13.2
400	16	PN 6/10	-	-	388	15.3
400	16	PN 16	-	-	386	15.2
400	16	-	Class 150	-	384	15.1
450	18	PN 6/10	-	-	440	17.3
450	18	PN 16	-	-	438	17.2
450	18	-	Class 150	-	436	17.2
500	20	PN 6/10	-	-	491	19.3
500	20	PN 16	-	-	487	19.2
500	20	-	Class 150	-	485	19.1
600	24	PN 6	-	-	592	23.3
600	24	PN 10	-	-	590	23.2

Nominal diameter		Pressure rating			Process connection internal diameter	
[mm]	[in]	EN (DIN) [bar]	ASME [psi]	JIS [bar]	PTFE [mm]	[in]
600	24	PN 16	-	-	588	23.2
600	24	-	Class 150	-	586	23.1

Materials

Transmitter housing

Order code for "Housing", option A "Compact, aluminum coated":
Aluminum, AlSi10Mg, coated

Cable entries/cable glands

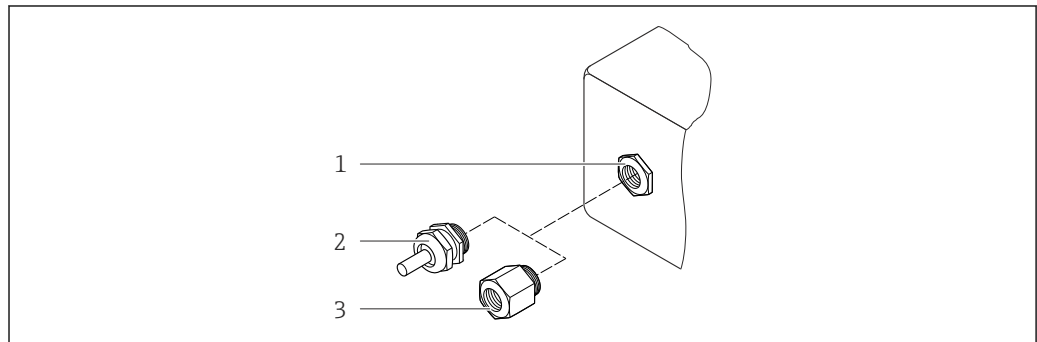

A0020640

20 Possible cable entries/cable glands

- 1 Cable entry in transmitter housing, wall-mount housing or connection housing with internal thread M20 x 1.5
- 2 Cable gland M20 x 1.5
- 3 Adapter for cable entry with internal thread G 1/2" or NPT 1/2"

Order code for "Housing", option A "Compact, coated aluminum"

The various cable entries are suitable for hazardous and non-hazardous areas.

Cable entry/cable gland	Material
Cable gland M20 x 1.5	Nickel-plated brass
Adapter for cable entry with internal thread G 1/2"	
Adapter for cable entry with internal thread NPT 1/2"	

Device plug

Electrical connection	Material
Plug M12x1	<ul style="list-style-type: none"> ▪ Socket: Stainless steel, 1.4404 (316L) ▪ Contact housing: Polyamide ▪ Contacts: Gold-plated brass

Sensor housing

- DN 15 to 300 (1/2 to 12"): coated aluminum AlSi10Mg
- DN 350 to 600 (14 to 24"): carbon steel with protective varnish

Measuring tubes

Stainless steel, 1.4301/304/1.4306/304L; for flanges made of carbon with Al/Zn protective coating (DN 15 to 300 (1/2 to 12")) or protective varnish (DN 350 to 600 (14 to 24"))

Liner

PTFE

Process connections

EN 1092-1 (DIN 2501)

Carbon steel, FE410WB ¹⁾/S235JRG2; Alloy C22, 2.4602 (UNS N06022)

ASME B16.5

Carbon steel, A105

JIS B2220

Carbon steel, S235JRG2/HII



List of all available process connections (→ 45)

Electrodes

Stainless steel, 1.4435 (F316L); Alloy C22, 2.4602 (UNS N06022); tantalum

Seals

In accordance with DIN EN 1514-1

Accessories

Ground disks

Stainless steel, 1.4435 (F316L); Alloy C22, 2.4602 (UNS N06022); tantalum; titanium

Fitted electrodes

Measuring electrodes, reference electrodes and electrodes for empty pipe detection:

Standard: stainless steel, 1.4435 (F316L); Alloy C22, 2.4602 (UNS N06022); tantalum

Process connections

- EN 1092-1 (DIN 2501): DN ≤ 300 (12") form A, DN ≥ 350 (14") flat face; dimensions as per DIN 2501, DN 65 PN 16 and DN 600 (24") PN 16 only as per EN 1092-1
- ASME B16.5
- JIS B2220



Surface roughness

Stainless steel electrodes, 1.4435 (F316L); Alloy C22, 2.4602 (UNS N06022); tantalum:
 ≤ 0.3 to 0.5 μm (11.8 to 19.7 μin)

(All data relate to parts in contact with fluid)

Operability

Operating concept

Operator-oriented menu structure for user-specific tasks

- Commissioning
- Operation
- Diagnostics
- Expert level

Quick and safe commissioning

- Individual menus for applications
- Menu guidance with brief explanations of the individual parameter functions

1) DN 15 to 300 (½ to 12") with Al/Zn protective coating; DN 350 to 600 (14 to 24") with protective varnish

Reliable operation

- Operation in the following languages:
 - Via "FieldCare" operating tool:
 - English, German, French, Spanish, Italian, Chinese, Japanese
 - Via Web browser:
 - English, German, French, Spanish, Italian, Dutch, Portuguese, Polish, Russian, Turkish, Chinese, Japanese, Bahasa (Indonesian), Vietnamese, Czech
- Uniform operating philosophy applied to operating tools and Web browser
- If replacing the electronic module, transfer the device configuration via the plug-in memory (HistoROM DAT) which contains the process and measuring device data and the event logbook. No need to reconfigure.
For devices with Modbus RS485, the data recovery function is implemented without the plug-in memory (HistoROM DAT).

Efficient diagnostics increase measurement availability

- Troubleshooting measures can be called up via the operating tools and Web browser
- Diverse simulation options
- Status indicated by several light emitting diodes (LEDs) on the electronic module in the housing compartment

Local display

The local display is only available with the following device version:
Order code for "Display; Operation", option **B**: 4-line; via communication

Display element

- 4-line liquid crystal display with 16 characters per line.
- White background lighting; switches to red in event of device errors.
- Format for displaying measured variables and status variables can be individually configured.
- Permitted ambient temperature for the display: -20 to $+60$ °C (-4 to $+140$ °F). The readability of the display may be impaired at temperatures outside the temperature range.

Remote operation**Via HART protocol**

This communication interface is present in the following device version:
Order code for "Output", option **B**: 4-20 mA HART, pulse/frequency/switch output

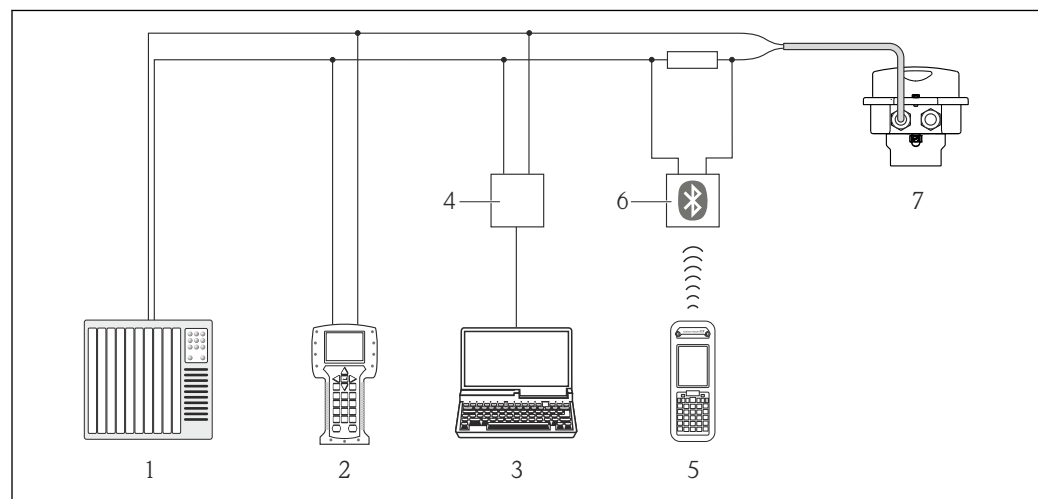

21 Options for remote operation via HART protocol

- 1 Control system (e.g. PLC)
- 2 Field Communicator 475
- 3 Computer with operating tool (e.g. FieldCare, AMS Device Manager, SIMATIC PDM)
- 4 Commubox FXA195 (USB)
- 5 Field Xpert SFX350 or SFX370
- 6 VIATOR Bluetooth modem with connecting cable
- 7 Transmitter

Via Ethernet-based fieldbus

This communication interface is present in the following device version:
Order code for "Output", option **N**: EtherNet/IP

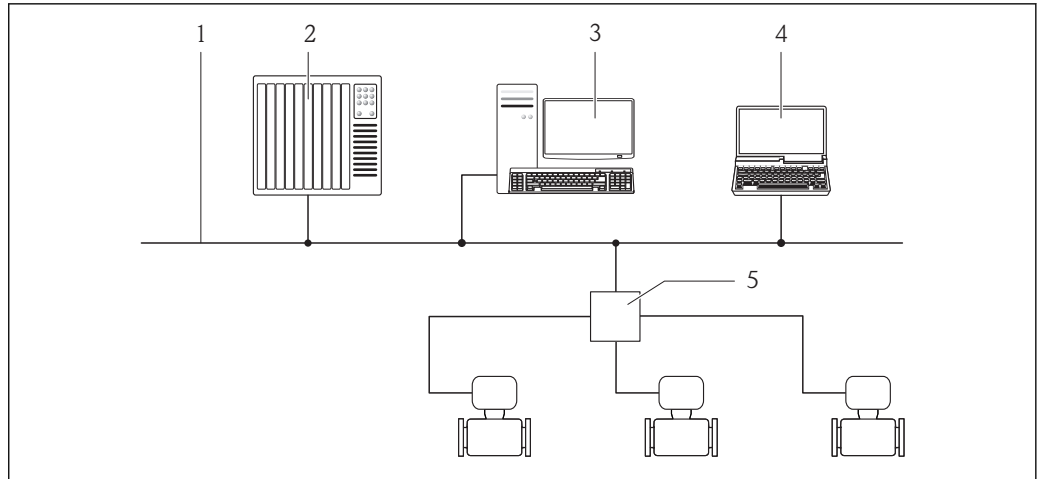

A0016961

- 1 Ethernet network
- 2 Automation system, e.g. "RSLogix" (Rockwell Automation)
- 3 Workstation for measuring device operation: with Add-on Profile Level 3 for "RSLogix 5000" (Rockwell Automation) or with Electronic Data Sheet (EDS)
- 4 Computer with Web browser (e.g. Internet Explorer) for accessing the integrated device Web server or with "FieldCare" operating tool with COM DTM "CDI Communication TCP/IP"
- 5 Ethernet switch

Via PROFIBUS DP network

This communication interface is present in the following device version:
Order code for "Output", option L: PROFIBUS DP

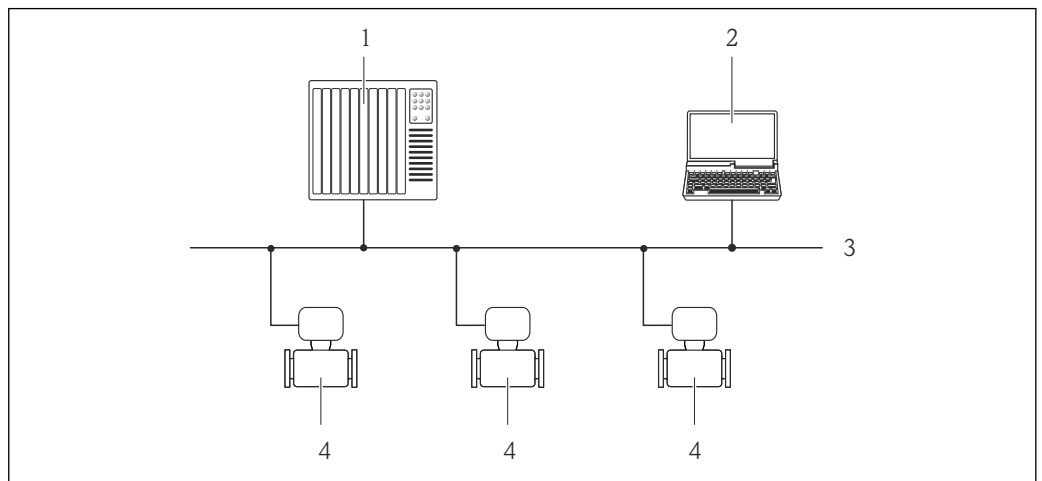

A0020903

- 1 Automation system
- 2 Computer with PROFIBUS network card
- 3 PROFIBUS DP network
- 4 Measuring device

Service interface

Service interface (CDI-RJ45)

This communication interface is present in the following device version:

- Order code for "Output", option B: 4-20 mA HART, pulse/frequency/switch output
- Order code for "Output", option L: PROFIBUS DP
- Order code for "Output", option N: EtherNet/IP

HART

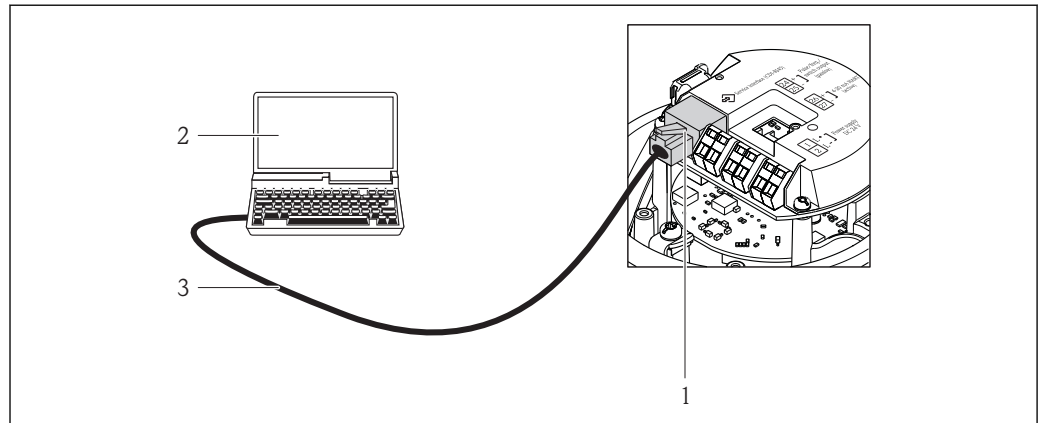

A0016926

22 Connection for the order code for "Output", option B: 4-20 mA HART, pulse/frequency/switch output

- 1 Service interface (CDI -RJ45) of the measuring device with access to the integrated Web server
- 2 Computer with Web browser (e.g. Internet Explorer) for accessing the integrated device Web server or with "FieldCare" operating tool with COM DTM "CDI Communication TCP/IP"
- 3 Standard Ethernet connecting cable with RJ45 plug

PROFIBUS DP

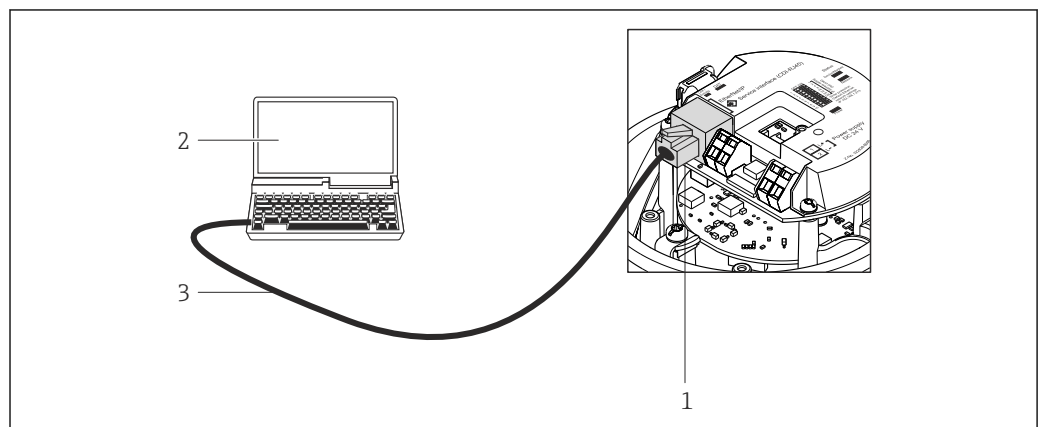

A0021270

23 Connection for order code for "Output", option L: PROFIBUS DP

- 1 Service interface (CDI -RJ45) of the measuring device with access to the integrated Web server
- 2 Computer with Web browser (e.g. Internet Explorer) for accessing the integrated device Web server or with "FieldCare" operating tool with COM DTM "CDI Communication TCP/IP"
- 3 Standard Ethernet connecting cable with RJ45 plug

EtherNet/IP

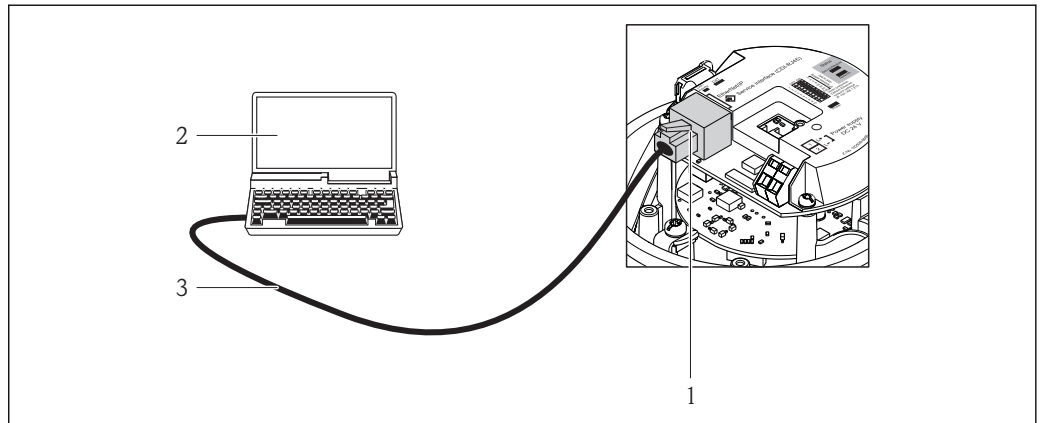

A0016940

24 Connection for order code for "Output", option N: EtherNet/IP

- 1 Service interface (CDI -RJ45) and EtherNet/IP interface of the measuring device with access to the integrated Web server
- 2 Computer with Web browser (e.g. Internet Explorer) for accessing the integrated device Web server or with "FieldCare" operating tool with COM DTM "CDI Communication TCP/IP"
- 3 Standard Ethernet connecting cable with RJ45 plug

Service interface (CDI)

This communication interface is present in the following device version:
 Order code for "Output", option **M**: Modbus RS485

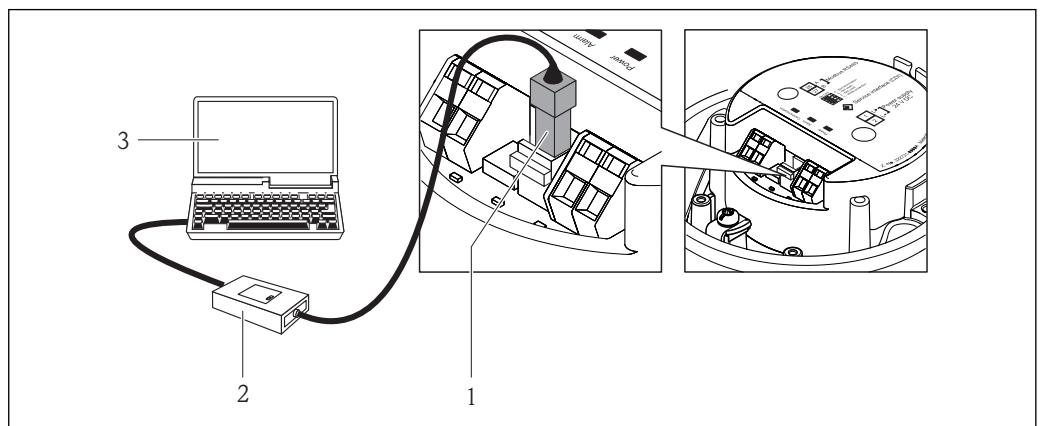

A0016925

- 1 Service interface (CDI) of the measuring device
- 2 Commubox FXA291
- 3 Computer with "FieldCare" operating tool with COM DTM "CDI Communication FXA291"

Certificates and approvals

CE mark

The measuring system is in conformity with the statutory requirements of the applicable EC Directives. These are listed in the corresponding EC Declaration of Conformity along with the standards applied.

Endress+Hauser confirms successful testing of the device by affixing to it the CE mark.

C-Tick symbol

The measuring system meets the EMC requirements of the "Australian Communications and Media Authority (ACMA)".

Ex approval

The measuring device is certified for use in hazardous areas and the relevant safety instructions are provided in the separate "Safety Instructions" (XA) document. Reference is made to this document on the nameplate.

 The separate Ex documentation (XA) containing all the relevant explosion protection data is available from your Endress+Hauser sales center.

ATEX, IECEx

Currently, the following versions for use in hazardous areas are available:

Ex nA

Category	Type of protection
IIG	Ex nA IIC T6-T1 Gc

Certification PROFIBUS**PROFIBUS interface**

The measuring device is certified and registered by the PROFIBUS User Organization (PNO). The measuring system meets all the requirements of the following specifications:

- Certified in accordance with PROFIBUS PA Profile 3.02
- The device can also be operated with certified devices of other manufacturers (interoperability)

Modbus RS485 certification

The measuring device meets all the requirements of the MODBUS/TCP conformity test and has the "MODBUS/TCP Conformance Test Policy, Version 2.0". The measuring device has successfully passed all the test procedures carried out and is certified by the "MODBUS/TCP Conformance Test Laboratory" of the University of Michigan.

EtherNet/IP certification

The measuring device is certified and registered by the ODVA (Open Device Vendor Association). The measuring system meets all the requirements of the following specifications:

- Certified in accordance with the ODVA Conformance Test
- EtherNet/IP Performance Test
- EtherNet/IP PlugFest compliance
- The device can also be operated with certified devices of other manufacturers (interoperability)

Pressure Equipment Directive

- With the PED/G1/x (x = category) marking on the sensor nameplate, Endress+Hauser confirms compliance with the "Essential Safety Requirements" specified in Annex I of the Pressure Equipment Directive 97/23/EC.
- Devices bearing this marking (PED) are suitable for the following types of medium: Media in Group 1 and 2 with a vapor pressure greater than, or smaller and equal to 0.5 bar (7.3 psi)
- Devices not bearing this marking (PED) are designed and manufactured according to good engineering practice. They meet the requirements of Art.3 Section 3 of the Pressure Equipment Directive 97/23/EC. The range of application is indicated in tables 6 to 9 in Annex II of the Pressure Equipment Directive.

Other standards and guidelines

- EN 60529
Degrees of protection provided by enclosures (IP code)
- EN 61010-1
Safety requirements for electrical equipment for measurement, control and laboratory use
- IEC/EN 61326
Emission in accordance with Class A requirements. Electromagnetic compatibility (EMC requirements).
- NAMUR NE 21
Electromagnetic compatibility (EMC) of industrial process and laboratory control equipment
- NAMUR NE 32
Data retention in the event of a power failure in field and control instruments with microprocessors
- NAMUR NE 43
Standardization of the signal level for the breakdown information of digital transmitters with analog output signal.
- NAMUR NE 53
Software of field devices and signal-processing devices with digital electronics

- NAMUR NE 105
Specifications for integrating fieldbus devices in engineering tools for field devices
- NAMUR NE 107
Self-monitoring and diagnosis of field devices
- NAMUR NE 131
Requirements for field devices for standard applications

Ordering information

Detailed ordering information is available from the following sources:

- In the Product Configurator on the Endress+Hauser website: www.endress.com → Select country → Instruments → Select device → Product page function: Configure this product
- From your Endress+Hauser Sales Center: www.endress.com/worldwide



Product Configurator - the tool for individual product configuration

- Up-to-the-minute configuration data
- Depending on the device: Direct input of measuring point-specific information such as measuring range or operating language
- Automatic verification of exclusion criteria
- Automatic creation of the order code and its breakdown in PDF or Excel output format
- Ability to order directly in the Endress+Hauser Online Shop

Application packages

Many different application packages are available to enhance the functionality of the device. Such packages might be needed to address safety aspects or specific application requirements.

The application packages can be ordered from Endress+Hauser either directly with the device or subsequently. Detailed information on the order code in question is available from your local Endress+Hauser sales center or on the product page of the Endress+Hauser website: www.endress.com.

Package	Description
Cleaning Electrode cleaning circuit (ECC)	The electrode cleaning circuit (ECC) function has been developed to have a solution for applications where magnetite (Fe ₃ O ₄) deposits frequently occur (e.g. hot water). Since magnetite is highly conductive this build up leads to measuring errors and ultimately to the loss of signal. The application package is designed to AVOID build up of highly conductive matter and thin layers (typical of magnetite).
Heartbeat Technology Heartbeat Verification +Monitoring	<p>Heartbeat Monitoring: Continuously supplies monitoring data, which are characteristic of the measuring principle, for an external condition monitoring system. This makes it possible to:</p> <ul style="list-style-type: none"> ■ Draw conclusions - using these data and other information - about the impact the measuring application has on the measuring performance over time. ■ Schedule servicing in time. ■ Monitor the product quality, e.g. gas pockets. <p>Heartbeat Verification: Makes it possible to check the device functionality on demand when the device is installed, without having to interrupt the process.</p> <ul style="list-style-type: none"> ■ Access via onsite operation or other operating interfaces, such as FieldCare for instance. ■ Documentation of device functionality within the framework of manufacturer specifications, for proof testing for instance. ■ End-to-end, traceable documentation of the verification results, including report. ■ Makes it possible to extend calibration intervals in accordance with operator's risk assessment.

Accessories

Various accessories, which can be ordered with the device or subsequently from Endress+Hauser, are available for the device. Detailed information on the order code in question is available from your local Endress+Hauser sales center or on the product page of the Endress+Hauser website: www.endress.com.

Device-specific accessories







For the transmitter

Accessories	Description
Ground cable	Set, consisting of two ground cables for potential equalization.



For the sensor

Accessories	Description
Ground disks	Are used to ground the fluid in lined measuring tubes to ensure proper measurement.  For details, see Installation Instructions EA00070D

Communication-specific accessories

Accessories	Description
Commubox FXA195 HART	For intrinsically safe HART communication with FieldCare via the USB interface.  For details, see "Technical Information" TI00404F
HART Loop Converter HMX50	Is used to evaluate and convert dynamic HART process variables to analog current signals or limit values.  For details, see "Technical Information" TI00429F and Operating Instructions BA00371F
Wireless HART adapter SWA70	Is used for the wireless connection of field devices. The WirelessHART adapter can be easily integrated into field devices and existing infrastructures, offers data protection and transmission safety and can be operated in parallel with other wireless networks with minimum cabling complexity.  For details, see Operating Instructions BA00061S
Fieldgate FXA320	Gateway for the remote monitoring of connected 4-20 mA measuring devices via a Web browser.  For details, see "Technical Information" TI00025S and Operating Instructions BA00053S
Fieldgate FXA520	Gateway for the remote diagnostics and remote configuration of connected HART measuring devices via a Web browser.  For details, see "Technical Information" TI00025S and Operating Instructions BA00051S
Field Xpert SFX350	Field Xpert SFX350 is a mobile computer for commissioning and maintenance. It enables efficient device configuration and diagnostics for HART and FOUNDATION Fieldbus devices in the non-Ex area .  For details, see Operating Instructions BA01202S
Field Xpert SFX370	Field Xpert SFX370 is a mobile computer for commissioning and maintenance. It enables efficient device configuration and diagnostics for HART and FOUNDATION Fieldbus devices in the non-Ex area and the Ex area .  For details, see Operating Instructions BA01202S

Service-specific accessories

Accessories	Description
Applicator	<p>Software for selecting and sizing Endress+Hauser measuring devices:</p> <ul style="list-style-type: none"> Calculation of all the necessary data for identifying the optimum flowmeter: e.g. nominal diameter, pressure loss, accuracy or process connections. Graphic illustration of the calculation results <p>Administration, documentation and access to all project-related data and parameters over the entire life cycle of a project.</p> <p>Applicator is available:</p> <ul style="list-style-type: none"> Via the Internet: https://wapps.endress.com/applicator On CD-ROM for local PC installation.
W@M	<p>Life cycle management for your plant</p> <p>W@M supports you with a wide range of software applications over the entire process: from planning and procurement, to the installation, commissioning and operation of the measuring devices. All the relevant device information, such as the device status, spare parts and device-specific documentation, is available for every device over the entire life cycle.</p> <p>The application already contains the data of your Endress+Hauser device. Endress+Hauser also takes care of maintaining and updating the data records.</p> <p>W@M is available:</p> <ul style="list-style-type: none"> Via the Internet: www.endress.com/lifecyclemanagement On CD-ROM for local PC installation.
FieldCare	<p>FDT-based plant asset management tool from Endress+Hauser.</p> <p>It can configure all smart field units in your system and helps you manage them. By using the status information, it is also a simple but effective way of checking their status and condition.</p> <p> For details, see Operating Instructions BA00027S and BA00059S</p>
Commubox FXA291	<p>Connects Endress+Hauser field devices with a CDI interface (= Endress+Hauser Common Data Interface) and the USB port of a computer or laptop.</p> <p> For details, see "Technical Information" TI00405C</p>

System components

Accessories	Description
Memograph M graphic display recorder	<p>The Memograph M graphic display recorder provides information on all relevant measured variables. Measured values are recorded correctly, limit values are monitored and measuring points analyzed. The data are stored in the 256 MB internal memory and also on a SD card or USB stick.</p> <p> For details, see "Technical Information" TI00133R and Operating Instructions BA00247R</p>

Supplementary documentation

-  For an overview of the scope of the associated Technical Documentation, refer to the following:
- The CD-ROM provided for the device (depending on the device version, the CD-ROM might not be part of the delivery!)
 - The *W@M Device Viewer* : Enter the serial number from the nameplate (www.endress.com/deviceviewer)
 - The *Endress+Hauser Operations App*: Enter the serial number from the nameplate or scan the 2-D matrix code (QR code) on the nameplate.

Standard documentation

Brief Operating Instructions

Measuring device	Documentation code
Promag E 100	KA01171D

Operating Instructions

Measuring device	Documentation code			
	HART	PROFIBUS DP	Modbus RS485	EtherNet/IP
Promag E 100	BA01305D	BA01307D	BA01306D	BA01308D

**Supplementary device-
dependent documentation****Safety Instructions**

Contents	Documentation code
ATEX/IECEX Ex nA	XA01090D

Special Documentation

Contents	Documentation code
Information on the Pressure Equipment Directive	SD01056D
Modbus RS485 Register Information	SD01148D
Heartbeat Technology	SD01149D

Installation Instructions

Contents	Documentation code
Installation Instructions for spare part sets	Specified for each individual accessory (→ 52)

Registered trademarks**HART®**

Registered trademark of the HART Communication Foundation, Austin, USA

PROFIBUS®

Registered trademark of the PROFIBUS User Organization, Karlsruhe, Germany

Modbus®

Registered trademark of SCHNEIDER AUTOMATION, INC.

EtherNet/IP™

Trademark of ODVA, Inc.

Microsoft®

Registered trademark of the Microsoft Corporation, Redmond, Washington, USA

Applicator®, FieldCare®, Field Xpert™, HistoROM®, Heartbeat Technology™

Registered or registration-pending trademarks of the Endress+Hauser Group



www.addresses.endress.com
