

Compact Chlorine System CCE 1/CCE 3

**Factory-assembled panel for
simple measurement of free chlorine,
pH, Redox value and temperature**



Measuring system

Factory-assembled and wired panel comprises installed tubing, dirt-trap, sampling cock for DPD calibration sample. Check valve and different connectors, as well as flow assembly CCA 250 for secure and user-friendly operation of chlorine or chlorine dioxide measurement.

Transmitter, sensors and sensor connection cables have to be ordered separately according to the desired components.

Areas of application

Treatment and disinfection of:

- Drinking water
- Industrial water
- Swimming pool water
- Other process techniques

Your benefits

- A compact panel mounted system for monitoring chlorine, pH / Redox and temperature
- Pipe or hose connection using the special fitted adapters
- Flow assembly CCA 250 complete with sensors and transmitter(s) as well as various components for in- and outlet of the flow medium
All measuring cables covered by wiring ducts, saves time-consuming cable installation on site
- Transparent dirt trap for safe filtering of contaminants in the media stream.
- Simple visual check for dirt and correct flow
- Convenient calibration and cleaning of pH / Redox electrodes can be performed in the CCA 250 assembly making electrode removal unnecessary
- Sampling cock for quick withdrawal of the measuring medium for DPD measurement during chlorine calibration
- Check valve ensures trouble-free withdrawal of sensors even under pressure
- Integrated proximity switch alerts when minimum flow rate is undershot



2 versions

Compact chlorine system CCE 1

Mounting dimensions CCE 1

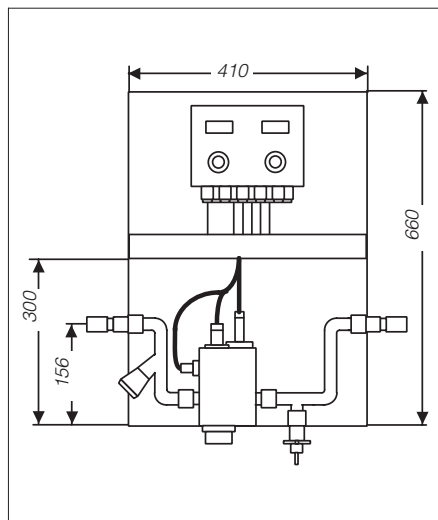

The compact chlorine measuring system CCE 1 can be equipped in two different ways:

- With Liquisys M CCM 253 transmitter for measurement of chlorine content, optional pH-compensated, or measurement of chlorine dioxide for drinking water and industrial water treatment.
- With combination measuring instrument PoolPAC CCM 360 for measurement of chlorine content, pH, redox and temperature for swimming pool water treatment according to DIN 19 643 or application in hot jacuzzis.

Compact chlorine system CCE 3

- 1 CCM 253 (chlorine), CPM 253 (pH), CPM 253 (Redox) instruments
- 2 cable duct
- 3 inlet
- 4 dirt trap
- 5 sensors
- 6 CCA 250
- 7 drain channel
- 8 check valve
- 9 sampling cock

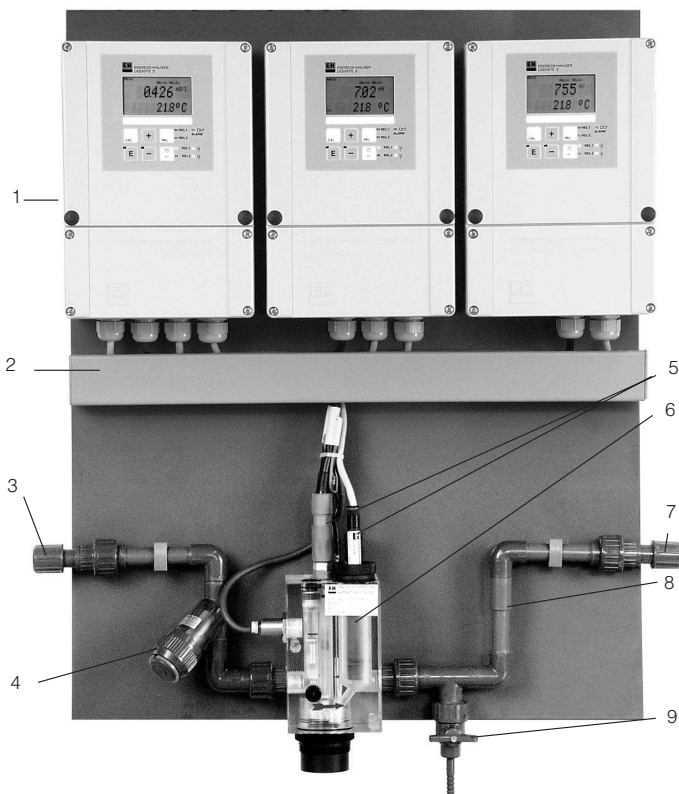

Application and areas of application

Mounting dimensions CCE 3

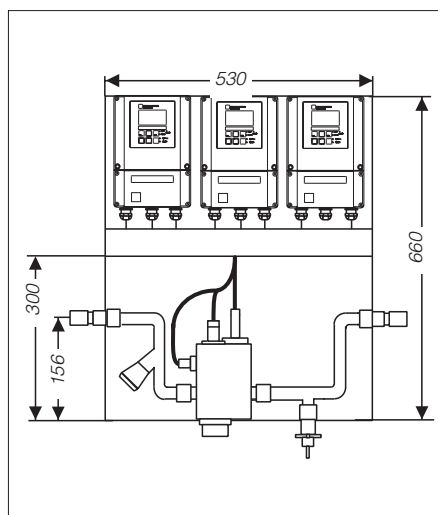

The compact chlorine measuring system CCE 3 is especially used for measurement of chlorine content (optional pH-compensated), chlorine dioxide, pH and temperature value for drinking water and industrial water treatment. It can be equipped with up to three Liquisys M transmitters, e. g. CCM 253 for chlorine, CPM 253 for pH and Redox.

Measuring value acquisition

The flow assembly CCA 250 is especially used for chlorine sensors CCS 140/CCS 141 or chlorine dioxide sensors CCS 240/CCS 241. Two additional spaces are provided for one combined Redox and one

combined pH electrode (e.g. types CPS 32-0PB2ESA and CPS 31-1EC2ESA). The plexiglass holder contains a needle valve to regulate the medium flow, and a flow meter for visual control of minimum flow rate.

If the CCA 250 flow assembly is used in conjunction with PoolPAC CCM 360 (combination instrument for pH, Redox, chlorine and temperature) designed specifically for swimming pool water measurements or with a Liquisys M CCM 253 transmitter, an inductive proximity switch triggers a "No-Flow" alarm.

A potential equalization pin is built into the unit for pH or redox measurements. The pH or redox electrode can be calibrated in situ. The screw cap is used as a calibration cup for this purpose.

CCA 250 with inductive proximity switch

- 1 pH-, Redox electrode
- 2 Suspense flow meter for flow rate control
- 3 Proximity switch INS
- 4 Inlet
- 5 Needle valve
- 6 Chlorine sensors CCS 140 or CCS 141
- 7 Drain channel

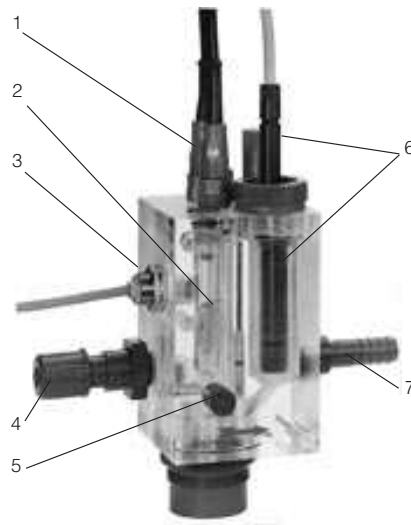

Dimensioned drawing CCA 250

- 1 Inductive proximity switch for automatic flow control
- 2 Minimum flow control 30 l/h
- 3 Inlet
- 4 Needle valve for flowrate regulation < 120 l/h
- 5 Cup (measurement chamber) for cleaning and calibrating the pH or Redox electrode
- 6 Chlorine measuring cell CCS 140/141 or chlorine dioxide measuring cell CCS 240/241
- 7 Chlorine measurement chamber
- 8 Outlet
- 9 Measurement chamber of pH/Redox electrode
- 10 Cap with calibration cup
- 11 Cup side
- 12 Closing side
- 13 Bleeder screw
- 14 Connection potential matching pin PM
- 15 Insertation point for one pH electrode and one Redox electrode

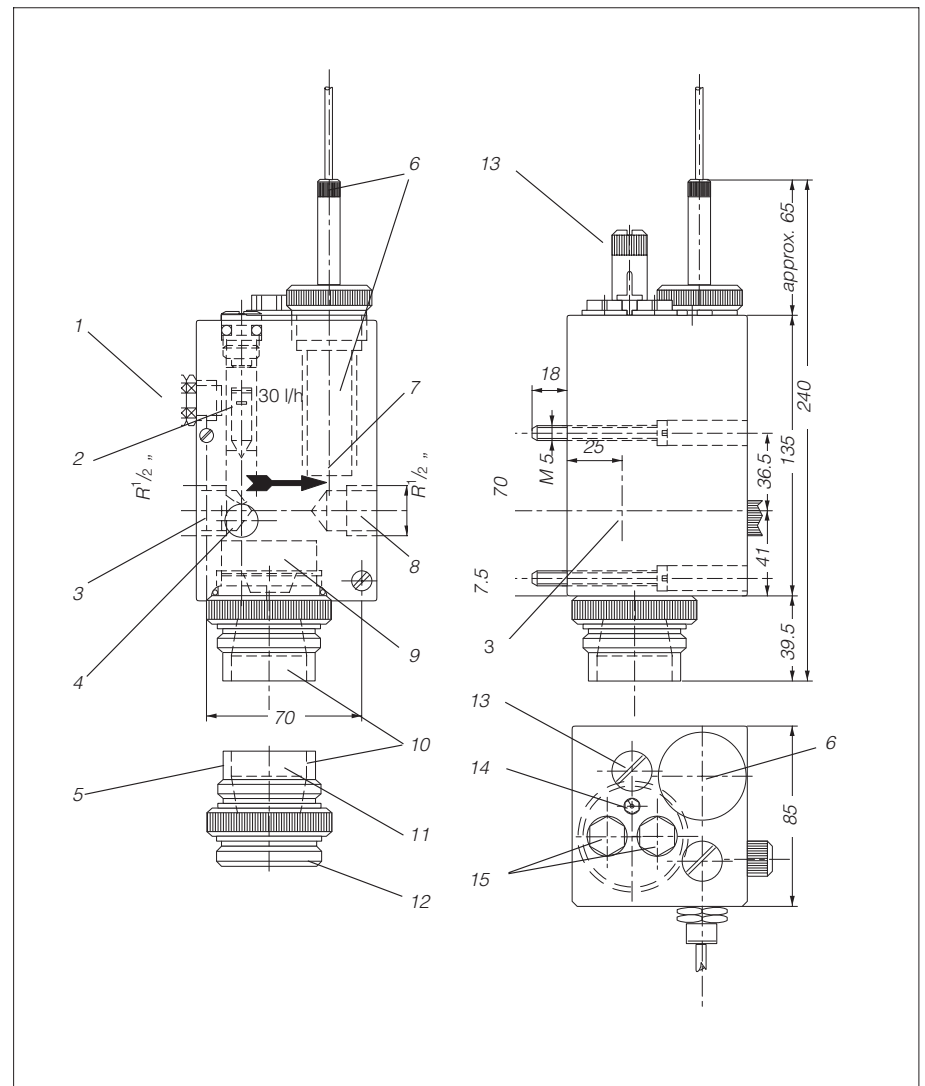

Technical Data

Dimensions of measuring station CCE 1 (W x H) 410 x 660
 Dimensions of measuring station CCE 3 (W x H) 530 x 660
 Panel material PVC
 Connections pipe connection OD 16 or D 6/12 hose connection
 Equipped at the factory with CCA 250 flow assembly
 according to customer's order
 with the following units to be added: e.g. with sensors CCS 140/141,
 or CCS 240 or CCS 241, pH and Redox electrodes CPS 31/32
 and transmitters Liquisys M CCM 253, CPM 253 (pH or Redox)
 (maximum of 3 units)
 or PoolPAC CCM 360 units
 Standard equipment connecting parts, pieces of tubing, dirt trap,
 sampling cock (for comparative DPD measurement),
 check valve, various connectors, cable duct

Subject to modifications.

Order-code

Type		order no.
CCE 1	chlorine mounting panel 1	50041731
CCE 3	chlorine mounting panel 2	50041733

Supplementary documentation

- | <input type="checkbox"/> Technical Information: | order no. |
|---------------------------------------------------------------------------------------------------------|------------------|
| - Sensors for free chlorine CCS 140/141 | 50028816 |
| - Sensors for chlorine dioxide CCS 240/241 | 50068514 |
| - Combined measuring instrument PoolPac CCM 360 | 50028589 |
| - Transmitter for free chlorine, chlorine dioxide,
pH and temperature measurement Liquisys M CCM 253 | 52502336 |
| - pH/Redox transmitter Liquisys M CPM 253 | 51500277 |
| - Microprocessor-controlled photometer for
chlorine or chlorine dioxide determination CCM 182 | 51507557 |

Endress+Hauser GmbH+Co. KG
- Instruments International -
 P.O. Box 22 22
 D-79574 Weil am Rhein
 Germany
 Tel. (0 76 21) 9 75 - 02
 Fax (0 76 21) 97 53 45
 Internet:
www.endress.com

Endress+Hauser
 The Power of Know How

