



Level



Pressure



Flow



Temperature

Liquid
Analysis

Registration

Systems
Components

Services



Solutions

Technical Information

Proline Promass 80/83 H, I

Coriolis Mass Flow Measuring System

The single-tube system with a “fit-and-forget” design:
easy to clean – hygienic – does not harm the material being
measured – chemical-resistant materials



Application

The Coriolis measuring principle operates independent of physical fluid properties, such as viscosity and density.

- Extremely accurate measurement of liquids and gases such as oils, lubricants, fuels, liquefied gases, cleaning agents and solvents, sterile media (blood plasma), foodstuffs and paints
- Fluid temperatures up to +200 °C
- Process pressures up to 100 bar
- Mass flow measurement up to 180 t/h

Approvals for hazardous area:

- ATEX, FM, CSA, TIIS

Approvals in the food industry/hygiene sector:

- 3A, EHEDG

Connection to all common process control systems:

- HART, PROFIBUS PA/DP, FOUNDATION Fieldbus, MODBUS

Relevant safety aspects:

- Secondary containment (up to 40 bar), Pressure Equipment Directive, SIL-2

Features and benefits

The Promass measuring devices make it possible to simultaneously record several process variables (mass/density/temperature) for various process conditions during measuring operation.

The uniform **Proline transmitter concept** includes:

- Modular device and operating concept resulting in a higher degree of efficiency
- Software options for batching and concentration measurement for extended range of application
- Diagnostic ability and data back-up for increased process quality

The **Promass sensors**, tried and tested in over 100,000 applications, offer:

- Multivariable flow measurement in compact design
- Insensitivity to vibrations thanks to balanced single-tube measuring system
- Immune from external piping forces due to robust design
- Easy installation without taking inlet and outlet runs into consideration



Table of contents

Function and system design	3	Mechanical construction	23
Measuring principle	3	Design, dimensions	23
Measuring system	4	Weight	38
Input	5	Materials	39
Measured variable	5	Material load curves	39
Measuring range	5	Process connections	42
Operable flow range	6	Human interface	43
Input signal	6	Display elements	43
Output	6	Unified control concept for both types of transmitter:	43
Output signal	6	Language groups	43
Signal on alarm	8	Remote operation	43
Load	8	Certificates and approvals	43
Low flow cut off	8	CE mark	43
Galvanic isolation	8	C-Tick symbol	43
Switching output	8	Ex approval	43
Power supply	9	Sanitary compatibility	43
Electrical connection Measuring unit	9	FOUNDATION Fieldbus	
Electrical connection, terminal assignment	10	certification	44
Electrical connection Remote version	11	PROFIBUS DP/PA certification	44
Supply voltage	11	MODBUS certification	44
Cable entries	12	Other standards and guidelines	44
Cable specification		Pressure Equipment Directive	44
Remote version	12	Functional safety	45
Power consumption	12	Ordering information	45
Power supply failure	12	Accessories	45
Potential equalization	12	Documentation	45
Performance characteristics	12	Registered trademarks	46
Reference operating conditions	12		
Maximum measured error	12		
Repeatability	14		
Influence of medium temperature	15		
Influence of medium pressure	15		
Operating conditions: Installation	15		
Installation instructions	15		
Inlet and outlet runs	19		
Length of connecting cable	19		
System pressure	19		
Operating conditions: Environment	19		
Ambient temperature range	19		
Storage temperature	19		
Degree of protection	19		
Shock resistance	19		
Vibration resistance	19		
Electromagnetic compatibility (EMC)	19		
Operating conditions: Process	20		
Medium temperature range	20		
Medium pressure range (nominal pressure)	20		
Limiting flow	20		
Pressure loss	21		

Function and system design

Measuring principle

The measuring principle is based on the controlled generation of Coriolis forces. These forces are always present when both translational and rotational movements are superimposed.

$$F_C = 2 \cdot \Delta m (v \cdot \omega)$$

F_C = Coriolis force

Δm = moving mass

ω = rotational velocity

v = radial velocity in rotating or oscillating system

The amplitude of the Coriolis force depends on the moving mass Δm , its velocity v in the system, and thus on the mass flow. Instead of a constant angular velocity ω , the Promass sensor uses oscillation.

This causes the tube through which the fluid is flowing to oscillate. The Coriolis forces produced at the measuring tubes cause a phase shift in the tube oscillations (see illustration):

- If there is zero flow, i.e. when the fluid stands still, the oscillation measured at points A and B has the same phase, and thus there is no phase difference (1).
- Mass flow causes deceleration of the oscillation at the inlet of the tubes (2) and acceleration at the outlet (3).

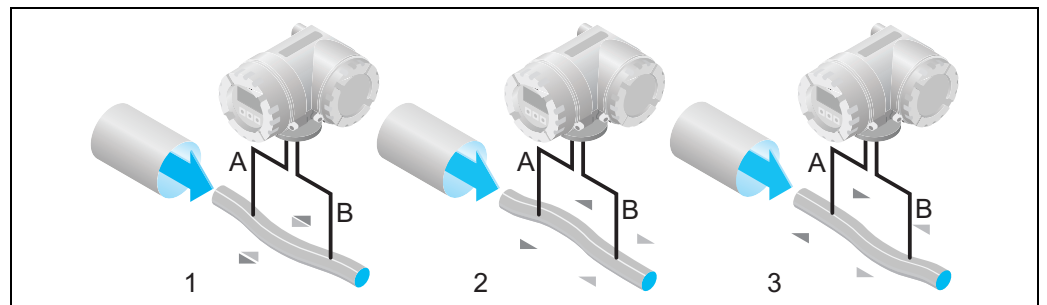

The phase difference (A-B) increases with increasing mass flow. Electrodynamic sensors register the tube oscillations at the inlet and outlet.

In the Promass I, the system balance required for proper measurement is created by exciting an eccentrically arranged swinging mass to antiphase oscillation. This patented TMB™ system (Torsion Mode Balanced System) guarantees perfect measurements, even in changing process and environmental conditions.

For the Promass H, the system balance is created by a counterweight that runs parallel to the measuring tube. This counterweight oscillates in antiphase to the measuring tubes and thus creates a balanced system. The patented ITB™ (Intrinsic Tube Balance) system ensures balance and stability, thus providing accurate measurements over a wide range of process and environmental conditions.

Therefore, the Promass H and Promass I are just as easy to install as the familiar two-tube systems!

Consequently, no special measures for attachment are required in front of or behind the sensor.

The measuring principle operates independently of temperature, pressure, viscosity, conductivity and flow profile.

Density measurement

The measuring tube is continuously excited at its resonance frequency. A change in the mass and thus the density of the oscillating system (comprising the measuring tube and fluid) results in a corresponding, automatic adjustment in the oscillation frequency. Resonance frequency is thus a function of fluid density. The microprocessor utilizes this relationship to obtain a density signal.

Temperature measurement

The temperature of the measuring tube is determined in order to calculate the compensation factor due to temperature effects. This signal corresponds to the process temperature and is also available as an output.

Measuring system

The measuring system consists of a transmitter and a sensor. Two versions are available:

- Compact version: transmitter and sensor form a mechanical unit.
- Remote version: transmitter and sensor are mounted physically separate from one another.

Transmitter

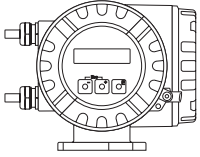
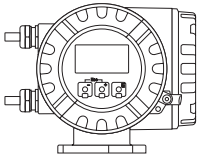
<p>Promass 80</p>  <p style="text-align: right; font-size: small;">a0003671</p>	<ul style="list-style-type: none"> ■ Two-line liquid-crystal display ■ Operation with push buttons
<p>Promass 83</p>  <p style="text-align: right; font-size: small;">a0003672</p>	<ul style="list-style-type: none"> ■ Four-line liquid-crystal display ■ Operation with "Touch control" ■ Application-specific Quick Setup ■ Mass flow, volume flow, density and temperature measurement as well as calculated variables (e.g. fluid concentrations)

Sensor

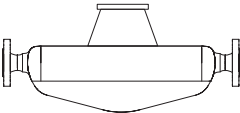
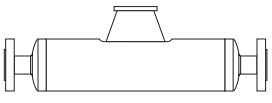
<p>H</p>  <p style="text-align: right; font-size: small;">a0003677</p>	<ul style="list-style-type: none"> ■ Single bent tube. Low pressure loss and chemically resistant material ■ Nominal diameters DN 8 to 50 ■ Tube material: zirconium 	<p>Documentation No. TI 052D/06/en</p>
<p>I</p>  <p style="text-align: right; font-size: small;">a0003678</p>	<ul style="list-style-type: none"> ■ Straight single-tube instrument. Minimal shear stress on fluid, hygienic design, low pressure loss. ■ Nominal diameters DN 8 to 80 ■ Tube material: titanium 	

Other sensors can be found in the separate documentation

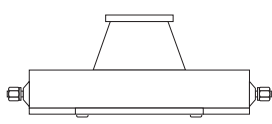
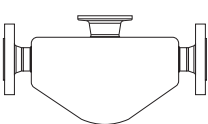
<p>A</p>  <p style="text-align: right; font-size: small;">a0003679</p>	<ul style="list-style-type: none"> ■ Single-tube system for highly accurate measurement of very small flows ■ Nominal diameters DN 1 to 4 ■ Tube material: stainless steel or Alloy C-22 	<p>Documentation No. TI 054D/06/en</p>
<p>E</p>  <p style="text-align: right; font-size: small;">a0002271</p>	<ul style="list-style-type: none"> ■ General purpose sensor, ideal replacement for volumetric flowmeters. ■ Nominal diameters DN 8 to 50 ■ Tube material: stainless steel 	<p>Documentation No. TI 061D/06/en</p>

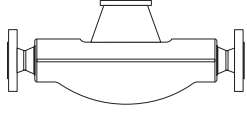
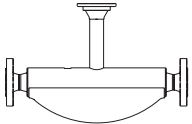
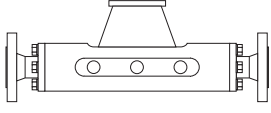
<p>F</p>  <p>a0003673</p>	<ul style="list-style-type: none"> ■ Universal sensor for fluid temperatures up to 200 °C. ■ Nominal diameters DN 8 to 250 ■ Tube material: stainless steel or Alloy C-22 	<p>Documentation No. TI 053D/06/en</p>
<p>F (High-temperature)</p>  <p>a0003675</p>	<ul style="list-style-type: none"> ■ Universal high-temperature sensor for fluid temperatures up to 350 °C. ■ Nominal diameters DN 25, 50, 80 ■ Tube material: Alloy C-22 	
<p>M</p>  <p>a0003676</p>	<ul style="list-style-type: none"> ■ Robust sensor for extreme process pressures, high requirements for the secondary containment and fluid temperatures up to 150 °C ■ Nominal diameters DN 8 to 80 ■ Tube material: titanium 	

Input

Measured variable

- Mass flow (proportional to the phase difference between two sensors mounted on the measuring tube to register a phase shift in the oscillation)
- Fluid density (proportional to resonance frequency of the measuring tube)
- Fluid temperature (measured with temperature sensors)

Measuring range

Measuring ranges for liquids

DN	Range for full scale values (liquids) $m_{\min(F)}$ to $m_{\max(F)}$
8	0 to 2000 kg/h
15	0 to 6500 kg/h
15 ¹⁾	0 to 18000 kg/h
25	0 to 18000 kg/h
25 ¹⁾	0 to 45000 kg/h
40	0 to 45000 kg/h
40 ¹⁾	0 to 70000 kg/h
50	0 to 70000 kg/h
50 ¹⁾	0 to 180000 kg/h
80 (Promass I only)	0 to 180000 kg/h
¹⁾ DN 15, 25, 40, 50 "FB" = Full bore versions of Promass I	

Measuring ranges for gases (not for Promass H)

The full scale values depend on the density of the gas. Use the formula below to calculate the full scale values:

$$m_{\max(G)} = m_{\max(F)} \cdot \rho_{(G)} / 160 \text{ [kg/m}^3\text{]}$$

$$m_{\max(G)} = \text{max. full scale value for gas [kg/h]}$$

$$m_{\max(F)} = \text{max. full scale value for liquid [kg/h]}$$

$$\rho_{(G)} = \text{Gas density in [kg/m}^3\text{] at operating conditions}$$

Here, $m_{\max(G)}$ can never be greater than $m_{\max(F)}$

Calculation example for gas:

- Sensor type: Promass I, DN 50
- Gas: air with a density of 60.3 kg/m^3 (at $20 \text{ }^\circ\text{C}$ and 50 bar)
- Measuring range (liquid): 70000 kg/h

Max. possible full scale value:

$$m_{\max(\text{G})} = m_{\max(\text{F})} \cdot \rho_{(\text{G})} : 160 [\text{kg/m}^3] = 70000 \text{ kg/h} \cdot 60.3 \text{ kg/h} : 160 \text{ kg/m}^3 = 26400 \text{ kg/h}$$

Recommended full scale values

See information in the "Limiting flow" Section → Page 20 ff.

Operable flow range Greater than 1000 : 1. Flow rates above the preset full scale value do not overload the amplifier, i.e. the totalizer values are registered correctly.

Input signal

Status input (auxiliary input):

$U = 3 \text{ to } 30 \text{ V DC}$, $R_i = 5 \text{ k}\Omega$, galvanically isolated.

Configurable for: totalizer reset, positive zero return, error message reset, zero point adjustment start, batching start/stop (optional).

Status input (auxiliary input) with PROFIBUS DP and MODBUS RS485:

$U = 3 \dots 30 \text{ V DC}$, $R_i = 3 \text{ kW}$, galvanically isolated

Switching level: $3 \dots 30 \text{ V DC}$, independent of polarity

Configurable for: totalizer(s) reset, measured value suppression, error-message reset, batching start/stop (optional), batch totalizer reset (optional)

Current input (only Promass 83)

Active/passive selectable, galvanically isolated, resolution: 2 A

- Active: $4 \text{ to } 20 \text{ mA}$, $R_L < 700 \Omega$, $U_{\text{out}} = 24 \text{ V DC}$, short-circuit proof
- Passive: $0/4 \text{ to } 20 \text{ mA}$, $R_i = 150 \Omega$, $U_{\text{max}} = 30 \text{ V DC}$

Output

Output signal

Promass 80

Current output:

Active/passive selectable, galvanically isolated, time constant selectable ($0.05 \text{ to } 100 \text{ s}$), full scale value selectable, temperature coefficient: typically $0.005\% \text{ o. f. s./}^\circ\text{C}$, resolution: $0.5 \mu\text{A}$

- Active: $0/4 \text{ to } 20 \text{ mA}$, $R_L < 700 \Omega$ (for HART: $R_L \geq 250 \Omega$)
- Passive: $4 \text{ to } 20 \text{ mA}$; supply voltage $U_S 18 \text{ to } 30 \text{ V DC}$; $R_i \geq 150 \Omega$

Pulse/frequency output:

Passive, open collector, 30 V DC , 250 mA , galvanically isolated.

- Frequency output: full scale frequency $2 \text{ to } 1000 \text{ Hz}$ ($f_{\text{max}} = 1250 \text{ Hz}$), on/off ratio 1:1, pulse width max. 2 s
- Pulse output: pulse value and pulse polarity can be selected, pulse width adjustable ($0.5 \text{ to } 2000 \text{ ms}$).

PROFIBUS PA interface:

- PROFIBUS PA in accordance with EN 50170 Volume 2, IEC 61158-2 (MBP), galvanically isolated
- Profile Version 3.0
- Current consumption: 11 mA
- Permissible supply voltage: 9 to 32 V
- Bus connection with integrated reverse polarity protection
- Error current FDE (Fault Disconnection Electronic) = 0 mA
- Data transmission rate: 31.25 kBit/s
- Signal encoding: Manchester II
- Function blocks: 4 x Analog Input, 1 x Totalizer
- Output data: Mass flow, Volume flow, Density, Temperature, Totalizer
- Input data: Positive zero return (ON/OFF), Zero point adjustment, Measuring mode, Totalizer control
- Bus address can be configured via miniature switches or via the local display (optional)

Promass 83

Current output:

Active/passive selectable, galvanically isolated, time constant selectable (0.05 to 100 s), full scale value selectable, temperature coefficient: typically 0.005% o. f. s./°C, resolution: 0.5 μ A

- Active: 0/4 to 20 mA, $R_L < 700 \Omega$ (for HART: $R_L \geq 250 \Omega$)
- Passive: 4 to 20 mA; supply voltage U_S 18 to 30 V DC; $R_i \geq 150 \Omega$

Pulse/frequency output:

active/passive selectable, galvanically isolated

- Active: 24 V DC, 25 mA (max. 250 mA during 20 ms), $R_L > 100 \Omega$
- Passive: open collector, 30 V DC, 250 mA
- Frequency output: full scale frequency 2 to 10000 Hz ($f_{max} = 12500$ Hz), on/off ratio 1:1, pulse width max. 2 s
- Pulse output: pulse value and pulse polarity selectable, pulse width configurable (0.05 to 2000 ms)

PROFIBUS DP interface:

- PROFIBUS DP in accordance with EN 50170 Volume 2
- Profile Version 3.0
- Data transmission rate: 9.6 kBaud to 12 MBaud
- Automatic data transmission rate recognition
- Signal encoding: NRZ Code
- Function blocks: 6 x Analog Input, 3 x Totalizer
- Output data: Mass flow, Volume flow, Corrected volume flow, Density, Reference density, Temperature, Totalizers 1 to 3
- Input data: Positive zero return (ON/OFF), Zero point adjustment, Measuring mode, Totalizer control
- Bus address can be configured via miniature switches or via the local display (optional)
- Available output combination → Page 10

PROFIBUS PA interface:

- PROFIBUS PA in accordance with EN 50170 Volume 2, IEC 61158-2 (MBP), galvanically isolated
- Data transmission rate: 31.25 kBit/s
- Current consumption: 11 mA
- Permissible supply voltage: 9 to 32 V
- Bus connection with integrated reverse polarity protection
- Error current FDE (Fault Disconnection Electronic): 0 mA
- Signal encoding: Manchester II
- Function blocks: 6 x Analog Input, 3 x Totalizer
- Output data: Mass flow, Volume flow, Corrected volume flow, Density, Reference density, Temperature, Totalizers 1 to 3
- Input data: Positive zero return (ON/OFF), Zero point adjustment, Measuring mode, Totalizer control
- Bus address can be set at the measuring device via miniature switches or the onsite display (optional)
- Available output combination → Page 10

MODBUS interface:

- MODBUS device type: slave
- Address range: 1 to 247
- Supported function codes: 03, 04, 06, 08, 16, 23
- Broadcast: supported with the function codes 06, 16, 23
- Physical interface: RS485 in accordance with EIA/TIA-485 standard
- Supported baud rate: 1200, 2400, 4800, 9600, 19200, 38400, 57600, 115200 Baud
- Transmission mode: RTU or ASCII
- Response times:
 - Direct data access = typically 25 to 50 ms
 - Auto-scan buffer (data range) = typically 3 to 5 ms
- Available output combination → Page 10

FOUNDATION Fieldbus interface:

- FOUNDATION Fieldbus H1, IEC 61158-2, galvanically isolated
- Data transmission rate: 31.25 kBit/s
- Current consumption: 12 mA
- Permissible supply voltage: 9 to 32 V
- Error current FDE (Fault Disconnection Electronic): 0 mA
- Bus connection with integrated reverse polarity protection
- Signal encoding: Manchester II
- ITK Version 4.01
- Function blocks: 7 x Analog Input, 1 x Digital Output, 1 x PID
- Output data: Mass flow, Volume flow, Corrected volume flow, Density, Reference density, Temperature, Totalizers 1 to 3
- Input data: Positive zero return (ON/OFF), Zero point adjustment, Measuring mode, Reset totalizer
- Link Master (LM) function is supported

Signal on alarm*Current output:*

Failsafe mode selectable (e.g. in accordance with NAMUR Recommendation NE 43)

Pulse/frequency output:

Failsafe mode selectable

Status output (Promass 80):

“Nonconductive” in the event of a fault or if the power supply fails

Relay output (Promass 83):

“Dead” in the event of a fault or if the power supply fails

Load

see “Output signal”

Low flow cut off

Switch points for low flow cut off are selectable.

Galvanic isolation

All circuits for inputs, outputs, and power supply are galvanically isolated from each other.

Switching output**Status output (Promass 80):**

Open collector, max. 30 V DC / 250 mA, galvanically isolated.
Configurable for: error messages, Empty Pipe Detection (EPD), flow direction, limit values.

Relay output (Promass 83):

Normally closed (NC or break) or normally open (NO or make) contacts available
(factory setting: relay 1 = NO, relay 2 = NC), max. 30 V / 0.5 A AC; 60 V / 0.1 A DC, galvanically isolated.

Power supply

Electrical connection Measuring unit

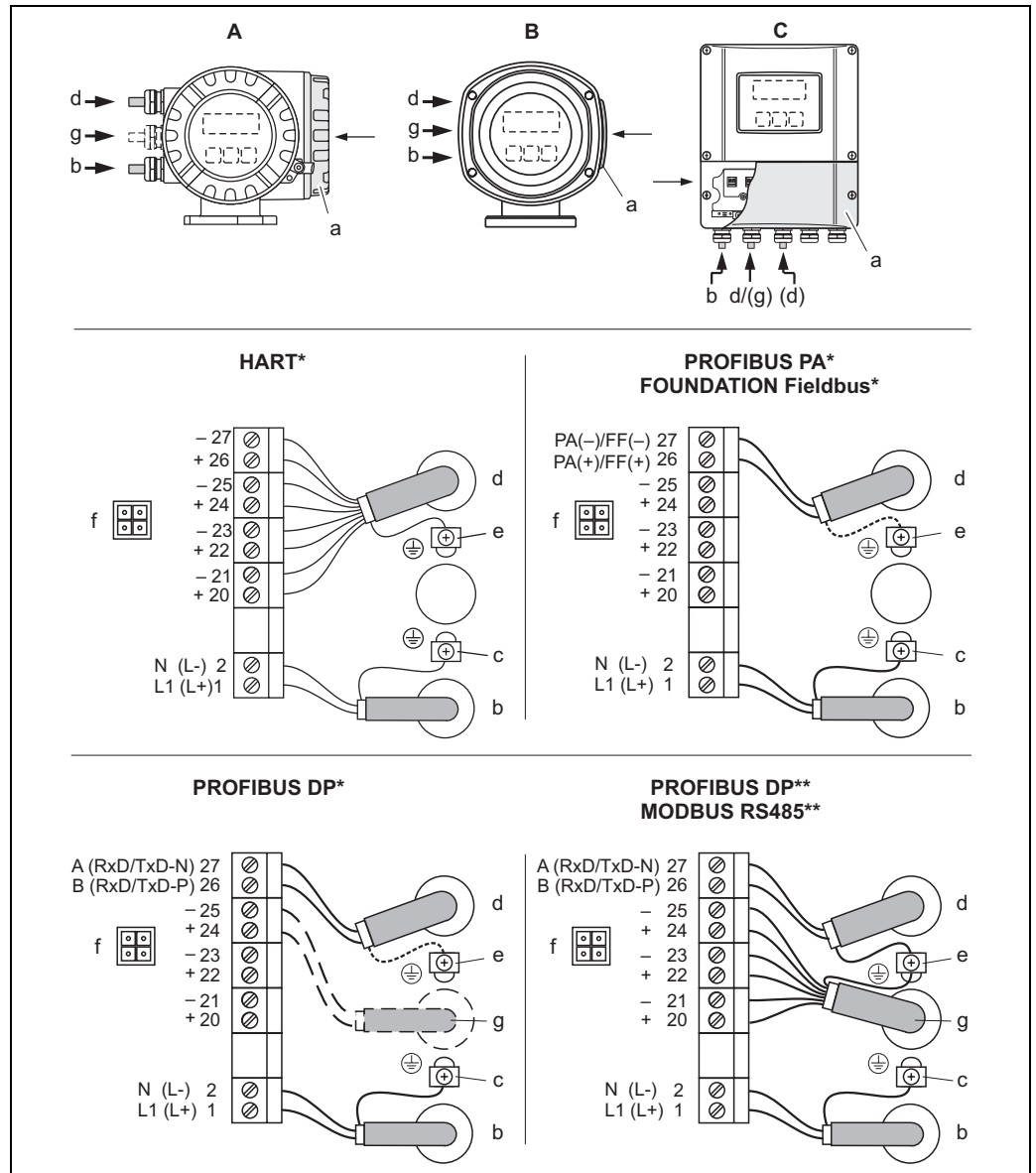

a0002441

Connecting the transmitter, cable cross-section: max. 2.5 mm²

- A View A (field housing)
- B View B (stainless steel field housing)
- C View C (wall-mount housing)

*) fixed communication board

*) flexible communication board

a Connection compartment cover

b Cable for power supply: 85 to 260 V AC, 20 to 55 V AC, 16 to 62 V DC

Terminal No. 1: L1 for AC, L+ for DC

Terminal No. 2: N for AC, L- for DC

c Ground terminal for protective ground

d Signal cable: see Terminal assignment → Page 10

Fieldbus cable:

Terminal No. 26: DP (A) / PA (+) / FF (+) / MODBUS RS485 (A) / (PA, FF: with reverse polarity protection)

Terminal No. 27: DP (B) / PA (-) / FF (-) / MODBUS RS485 (B) / (PA, FF: with reverse polarity protection)

e Ground terminal for signal cable shield / fieldbus cable / RS485 line

f Service adapter for connecting service interface FXA 193 (Fieldcheck, ToF Tool - Fieldtool Package)

g Signal cable: see Terminal assignment → Page 10

g Cable for external termination (only for PROFIBUS DP with permanent assignment communication board):

Terminal No. 24: +5 V

Terminal No. 25: DGND

Electrical connection,
terminal assignment

Promass 80

Order version	Terminal No. (inputs/outputs)			
	20 (+) / 21 (-)	22 (+) / 23 (-)	24 (+) / 25 (-)	26 (+) / 27 (-)
80***_*****A	-	-	Frequency output	Current output, HART
80***_*****D	Status input	Status output	Frequency output	Current output, HART
80***_*****H	-	-	-	PROFIBUS PA
80***_*****S	-	-	Frequency output Ex i, passive	Current output Ex i Active, HART
80***_*****T	-	-	Frequency output Ex i, passive	Current output Ex i Passive, HART
80***_*****8	Status input	Frequency output	Current output 2	Current output 1, HART

Promass 83

The inputs and outputs on the communication board can be either permanently assigned (fixed) or variable (flexible), depending on the version ordered (see table). Replacements for modules which are defective or which have to be replaced can be ordered as accessories.

Order version	Terminal No. (inputs/outputs)			
	20 (+) / 21 (-)	22 (+) / 23 (-)	24 (+) / 25 (-)	26 (+) / 27 (-)
<i>Fixed communication boards (permanent assignment)</i>				
83***_*****A	-	-	Frequency output	Current output HART
83***_*****B	Relay output	Relay output	Frequency output	Current output HART
83***_*****F	-	-	-	PROFIBUS PA, Ex i
83***_*****G	-	-	-	FOUNDATION Fieldbus Ex i
83***_*****H	-	-	-	PROFIBUS PA
83***_*****J	-	-	+5V (ext. termination)	PROFIBUS DP
83***_*****K	-	-	-	FOUNDATION Fieldbus
83***_*****Q	-	-	Status input	MODBUS RS485
83***_*****R	-	-	Current output 2 Ex i, active	Current output 1 Ex i active, HART
83***_*****S	-	-	Frequency output Ex i, passive	Current output Ex i Active, HART
83***_*****T	-	-	Frequency output Ex i, passive	Current output Ex i Passive, HART
83***_*****U	-	-	Current output 2 Ex i, passive	Current output 1 Ex i passive, HART
<i>Flexible communication boards</i>				
83***_*****C	Relay output 2	Relay output 1	Frequency output	Current output HART
83***_*****D	Status input	Relay output	Frequency output	Current output HART
83***_*****E	Status input	Relay output	Current output 2	Current output 1 HART

Order version	Terminal No. (inputs/outputs)			
	20 (+) / 21 (-)	22 (+) / 23 (-)	24 (+) / 25 (-)	26 (+) / 27 (-)
83***_*****L	Status input	Relay output 2	Relay output 1	Current output HART
83***_*****M	Status input	Frequency output 2	Frequency output 1	Current output HART
83***_*****N	Current output	Frequency output	Status input	MODBUS RS485
83***_*****P	Current output	Frequency output	Status input	PROFIBUS DP
83***_*****V	Relay output 2	Relay output 1	Status input	PROFIBUS DP
83***_*****W	Relay output	Current output 3	Current output 2	Current output 1 HART
83***_*****0	Status input	Current output 3	Current output 2	Current output 1 HART
83***_*****2	Relay output	Current output 2	Frequency output	Current output 1 HART
83***_*****3	Current input	Relay output	Current output 2	Current output 1 HART
83***_*****4	Current input	Relay output	Frequency output	Current output HART
83***_*****5	Status input	Current input	Frequency output	Current output HART
83***_*****6	Status input	Current input	Current output 2	Current output HART
83***_*****7	Relay output 2	Relay output 1	Status input	MODBUS RS485

Electrical connection Remote version

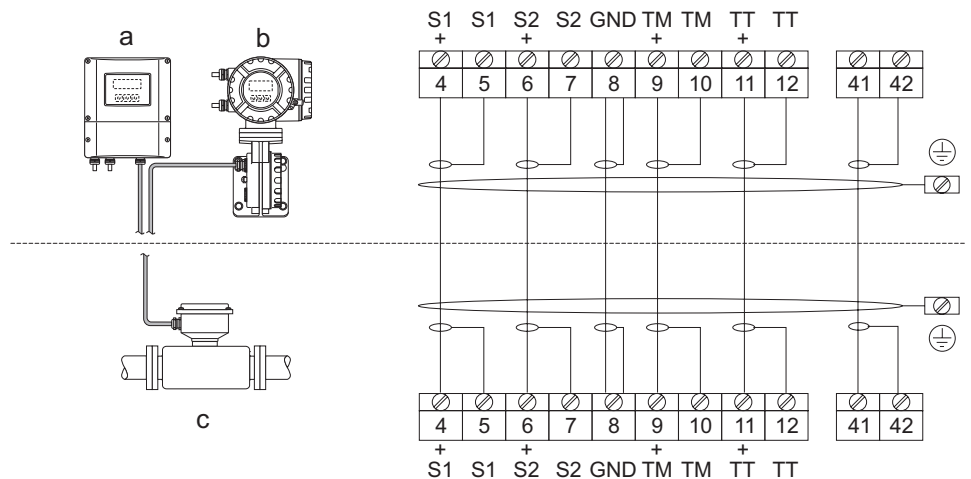

a0003681

Connecting the remote version

a Wall-mount housing: non-hazardous area and ATEX II3G / zone 2 → see separate “Ex documentation”

b Wall-mount housing: ATEX II2G / Zone 1 /FM/CSA → see separate “Ex documentation”

c Remote version, flanged version

Terminal No.: 4/5 = gray; 6/7 = green; 8 = yellow; 9/10 = pink; 11/12 = white; 41/42 = brown

Supply voltage

85 to 260 V AC, 45 to 65 Hz

20 to 55 V AC, 45 to 65 Hz

16 to 62 V DC

Cable entries	<p><i>Power-supply and signal cables (inputs/outputs):</i></p> <ul style="list-style-type: none"> ■ Cable entry M20 x 1.5 (8 to 12 mm) ■ Thread for cable entries, 1/2" NPT, G 1/2" <p><i>Connecting cable for remote version:</i></p> <ul style="list-style-type: none"> ■ Cable entry M20 x 1.5 (8 to 12 mm) ■ Thread for cable entries, 1/2" NPT, G 1/2"
Cable specification Remote version	<ul style="list-style-type: none"> ■ 6 x 0.38 mm² PVC cable with common shield and individually shielded cores ■ Conductor resistance: ≤ 50 Ω/km ■ Capacitance: core/shield: ≤ 420 pF/m ■ Cable length: max. 20 m ■ Permanent operating temperature: max. +105 °C <p>Operation in zones of severe electrical interference: The measuring device complies with the general safety requirements in accordance with EN 61010, the EMC requirements of EN 61326/A1, and NAMUR recommendation NE 21/43.</p>
Power consumption	<p>AC: <15 VA (including sensor) DC: <15 W (including sensor)</p> <p><i>Switch-on current:</i></p> <ul style="list-style-type: none"> ■ Max. 13.5 A (< 50 ms) at 24 V DC ■ Max. 3 A (< 5 ms) at 260 V AC
Power supply failure	<p>Promass 80</p> <p><i>Lasting min. 1 power cycle</i></p> <ul style="list-style-type: none"> ■ EEPROM saves measuring system data if the power supply fails ■ HistoROM/S-DAT: exchangeable data storage chip with sensor specific data (nominal diameter, serial number, calibration factor, zero point, etc.) <p>Promass 83</p> <p>Lasting min. 1 power cycle:</p> <ul style="list-style-type: none"> ■ EEPROM and T-DAT save the measuring system data if the power supply fails. ■ HistoROM/S-DAT: exchangeable data storage chip with sensor specific data (nominal diameter, serial number, calibration factor, zero point, etc.)
Potential equalization	No measures necessary.

Performance characteristics

Reference operating conditions	<p><i>Error limits following ISO/DIS 11631:</i></p> <ul style="list-style-type: none"> ■ 20 to 30 °C; 2 to 4 bar ■ Calibration systems as per national norms ■ Zero point calibrated under operating conditions ■ Field density calibrated (or special density calibration)
Maximum measured error	<p>The following values refer to the pulse/frequency output. Measured error at the current output is typically ±5 A.</p> <p>o.r. = of reading</p> <p>Mass flow (liquid):</p> <p><i>Promass 80 H, I:</i></p> <p>±0.175% ± [(zero point stability / measured value) · 100] % o.r.</p> <p><i>Promass 83 H, I:</i></p> <p>±0.125% ± [(zero point stability / measured value) · 100] % o.r.</p>

Mass flow (gas):

Promass 80/83 I:

$$\pm 0.50\% \pm [(zero\ point\ stability / measured\ value) \cdot 100]\% \text{ o.r.}$$

Volume flow (liquid)

Promass 80/83 H, I:

$$\pm 0.50\% \pm [(zero\ point\ stability / measured\ value) \cdot 100]\% \text{ o.r.}$$

Zero point stability (Promass H, I):

DN	Maximum full scale value in [kg/h] or [l/h]	Zero point stability	
		Promass H in [kg/h] or [l/h]	Promass I in [kg/h] or [l/h]
8	2000	0.20	0.20
15	6500	0.65	0.65
15 ¹⁾	18000	-	1.8
25	18000	1.8	1.8
25 ¹⁾	45000	-	4.5
40	45000	4.5	4.5
40 ¹⁾	70000	-	7.0
50	70000	7.0	7.0
50 ¹⁾	180000	-	18.0
80	180000	-	18.0

¹⁾ DN 15, 25, 40, 50 "FB" = Full bore versions of Promass I

Sample calculation

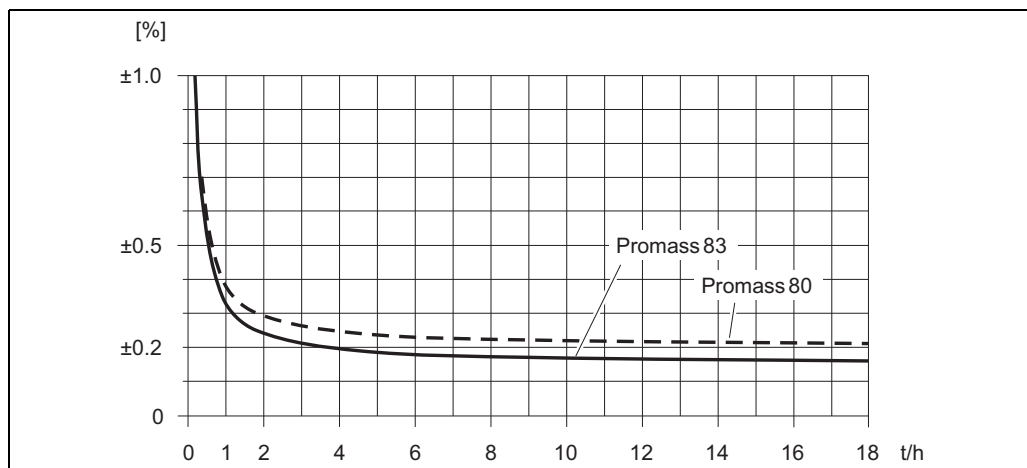

Max. measured error in % of measured value (example: Promass 80/83 I / DN 25)

Calculation example (mass flow, liquid):

Given: Promass 83 I / DN 25, flow measured value = 8000 kg/h

Max. measured error: $\pm 0.125\% \pm [(zero\ point\ stability / measured\ value) \cdot 100]\% \text{ o.r.}$

Max. measured error: $\pm 0.125\% \pm 1.8\text{ kg/h} : 8000\text{ kg/h} \cdot 100\% = \pm 0.15\%$

Density (liquid)

1 g/cc = 1 kg/l

Standard calibration:

Promass H

±0.02 g/cc

Promass I

±0.02 g/cc

Special density calibration (optional), calibration range: 0.8 to 1.8 g/cc, 5 to 80 °C:

Promass H

±0.002 g/cc

Promass I

±0.004 g/cc

After field density calibration or under reference conditions:

Promass H

±0.0010 g/cc

Promass I

±0.0020 g/cc

Temperature

Promass H, I:

±0.5 °C ±0.005 · T (T = fluid temperature in °C)

Repeatability**Mass flow (liquid):**

±0.05% ± [1/2 · (zero point stability / measured value) · 100]% o.r.

Mass flow (gas):

Promass I:

±0.25% ± [1/2 · (zero point stability / measured value) · 100]% o.r.

Volume flow (liquid):

±0.20% ± [1/2 · (zero point stability / measured value) · 100]% o.r.

o.r. = of reading

Zero point stability: see "Max. measured error" → Page 12 ff.

Calculation example (mass flow, liquid):

Given: Promass 83 I / DN 25, flow measured value = 8000 kg/h

Repeatability: ±0.05% ± [1/2 · (zero point stability / measured value) · 100]% o.r.

Repeatability: ±0.05% ± 1/2 · 1.8 kg/h : 8000 kg/h · 100% = ±0.061%

Density measurement (liquid)

1 g/cc = 1 kg/l

Promass I:

±0.001 g/cc

Promass H:

±0.0005 g/cc

Temperature measurement

$$\pm 0.25 \text{ }^\circ\text{C} \pm 0.0025 \cdot T \text{ (T = fluid temperature in } ^\circ\text{C)}$$
Influence of medium temperature

When there is a difference between the temperature for zero point adjustment and the process temperature, the typical measured error of the Promass sensor is $\pm 0.0002\%$ of the full scale value / $^\circ\text{C}$.

Influence of medium pressure

The table below shows the effect on accuracy of mass flow due to a difference between calibration pressure and process pressure.

DN	Promass H [% o.r./bar]	Promass I [% o.r./bar]
8	-0.017	0.006
15	-0.021	0.004
15 ¹⁾	–	0.006
25	-0.013	0.006
25 ¹⁾	–	No influence
40	-0.018	No influence
40 ¹⁾	–	0.006
50	-0.020	0.006
50 ¹⁾	–	0.003
80	–	0.003

* DN 15, 25, 40, 50 "FB" = Full bore versions of Promass I
o.r. = of reading

Operating conditions: Installation**Installation instructions**

Note the following points:

- No special measures such as supports are necessary. External forces are absorbed by the construction of the instrument, for example the secondary containment.
- The high oscillation frequency of the measuring tubes ensures that the correct operation of the measuring system is not influenced by pipe vibrations.
- No special precautions need to be taken for fittings which create turbulence (valves, elbows, T-pieces etc.), as long as no cavitation occurs.
- For mechanical reasons and to protect the pipe, support is recommended for heavy sensors.

Mounting location

Entrained air or gas bubbles in the measuring tube can result in an increase in measuring errors.

Therefore, avoid the following mounting locations in the pipe installation:

- Highest point of a pipeline. Risk of air accumulating.
- Directly upstream of a free pipe outlet in a vertical pipeline.

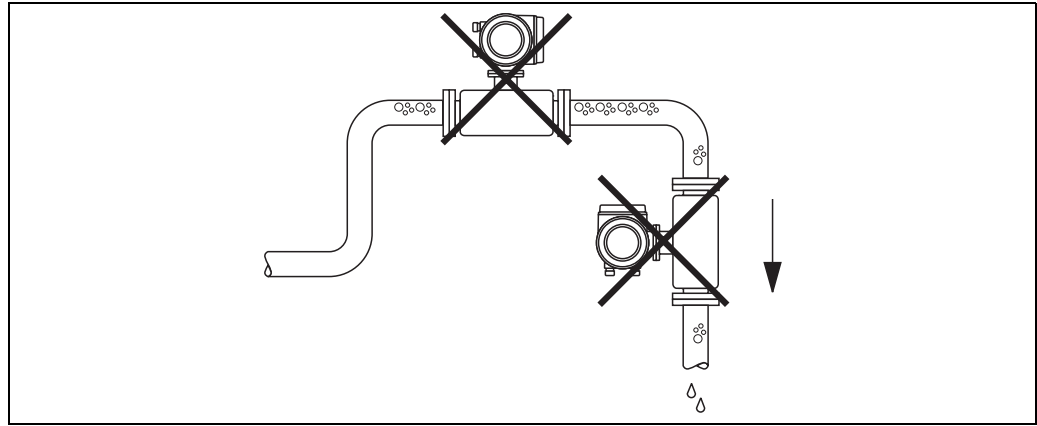

Mounting location

Notwithstanding the above, the installation proposal below permits installation in an open vertical pipeline. Pipe restrictions or the use of an orifice with a smaller cross-section than the nominal diameter prevent the sensor running empty while measurement is in progress.

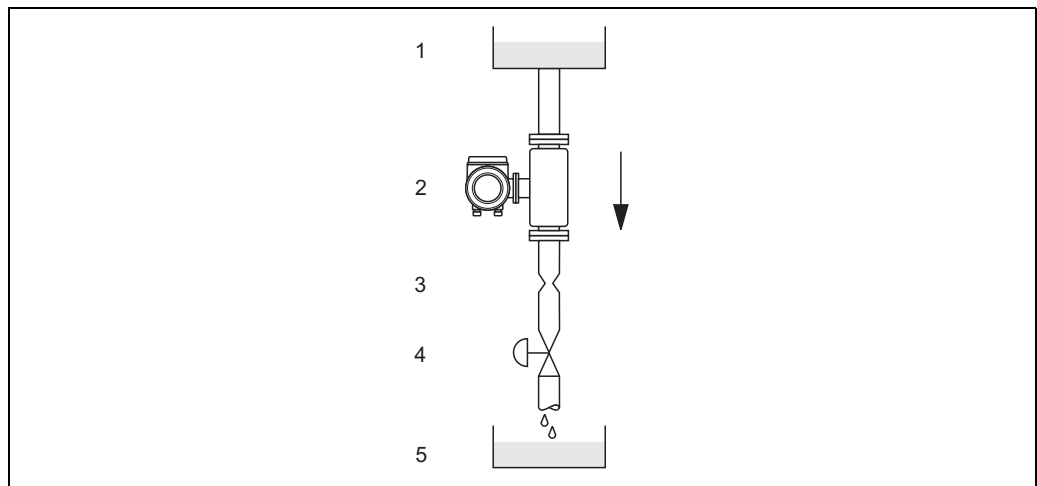

Installation in a down pipe (e.g. for batching applications)

- 1 Supply tank
- 2 Sensor
- 3 Orifice plate, pipe restriction (see Table)
- 4 Valve
- 5 Batching tank

Promass H, I / DN	8	15	15 ¹⁾	25	25 ¹⁾	40	40 ¹⁾	50	50 ¹⁾	80 ²⁾
∅ Orifice plate, pipe restriction [mm]	6	10	15	14	24	22	35	28	54	50

¹⁾ DN 15, 25, 40, 50 "FB" = Full bore versions of Promass I
²⁾ Promass I only

Orientation

Make sure that the direction of the arrow on the nameplate of the sensor matches the direction of flow (direction of fluid flow through the pipe).

Vertical (view V)

Recommended orientation with upward direction of flow. When fluid is not flowing, entrained solids will sink down and gases will rise away from the measuring tube. The measuring tubes can be completely drained and protected against solids buildup.

Horizontal

Promass H and Promass I can be installed in any orientation in a horizontal pipe run.

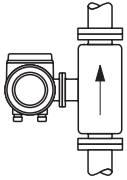
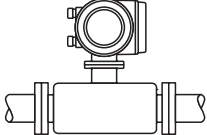
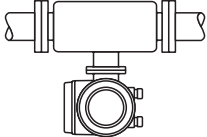
	Promass H, I: Standard, compact	Promass H, I: Standard, remote
<p>Fig. V: vertical orientation</p>  <p style="text-align: right; font-size: small;">a0004572</p>	✓✓	✓✓
<p>Fig. H1: horizontal orientation Transmitter head up</p>  <p style="text-align: right; font-size: small;">a0004576</p>	✓✓	✓✓
<p>Fig. H2: horizontal orientation Transmitter head down</p>  <p style="text-align: right; font-size: small;">a0004580</p>	✓✓ ①	✓✓ ①
<p>✓✓ = Recommended orientation ✓ = Orientation recommended in certain situations ✗ = Impermissible orientation</p>		

① = To ensure that the maximum permitted ambient temperature for the transmitter (–20 to +60 °C, optionally –40 to +60 °C) is not exceeded, for low-temperature fluids, we recommend the horizontal orientation with the transmitter head up (Fig. H1) or the vertical orientation (Fig. V).

Special installation instructions for Promass H

Caution!

The measuring tube of the Promass H is slightly curved. The position of the sensor, therefore, has to be matched to the fluid properties when the sensor is installed horizontally.

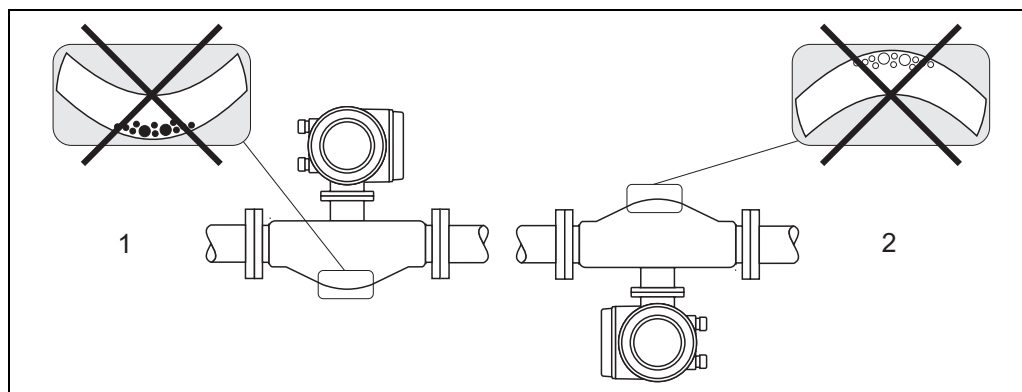

Horizontal installation with Promass H

- 1 Not suitable for fluids with entrained solids. Risk of solids accumulating.
- 2 Not suitable for outgassing fluids. Risk of air accumulating.

Heating

Some fluids require suitable measures to avoid heat transfer at the sensor. Heating can be electric, e.g. with heated elements, or by means of hot water or steam pipes made of copper.

Caution!

- Risk of electronics overheating! Consequently, make sure that the adapter between the sensor and transmitter and the connection housing of the remote version always remain free of insulating material. Note that a certain orientation might be required, depending on the fluid temperature.
- If using an electric trace heating system whose heating is regulated via phase angle control or pulse packages, influence on the measured values cannot be ruled out due to magnetic fields (i.e. for values that are greater than the values approved by the EN standard (sine 30 A/m)). In such cases, the sensor must be magnetically shielded.

The secondary containment can be shielded with tin plates or electric sheets without preferential direction (e.g. V330-35A) with the following properties:

- Relative magnetic permeability $\mu_r \geq 300$
- Plate thickness $d \geq 0.35$ mm

- Information on permitted temperature ranges → Page 20

Special heating jackets, which can be ordered separately from Endress+Hauser as an accessory, are available for the sensors.

Zero point adjustment

All Promass devices are calibrated to state-of-the-art technology. The zero point determined in this way is imprinted on the nameplate.

Calibration takes place under reference conditions. → Page 12 ff.

Therefore, Promass generally does **not** require zero point adjustment!

Experience shows that the zero point adjustment is advisable only in special cases:

- When the highest measuring accuracy is required and the flow rates are very low.
- Under extreme process or operating conditions (e.g. very high process temperatures or very high viscosity fluids).

Please note the following before carrying out the adjustment:

- The adjustment can only be performed with fluids that have no gas or solid contents.
- Zero point adjustment is performed with the measuring tubes completely filled and at zero flow ($v = 0$ m/s). This can be achieved, for example, with shutoff valves upstream and/or downstream of the sensor or by using existing valves and gates.
 - Normal operation → valves 1 and 2 open
 - Zero point adjustment *with* pump pressure → valve 1 open / valve 2 closed
 - Zero point adjustment *without* pump pressure → valve 1 closed / valve 2 open

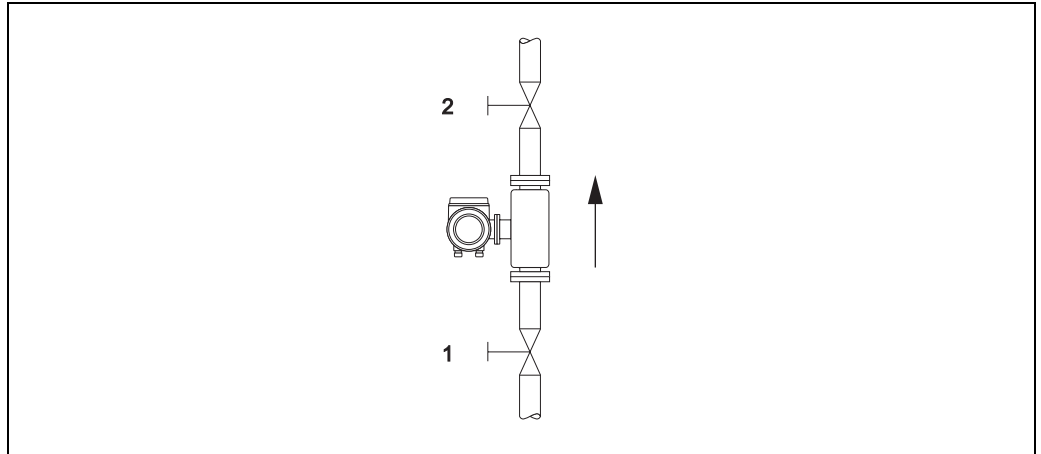

Zero point adjustment and shutoff valves

a0003601

Inlet and outlet runs	There are no installation requirements regarding inlet and outlet runs.
Length of connecting cable	Max. 20 meters (remote version)
System pressure	<p>It is important to ensure that cavitation does not occur, because it would influence the oscillation of the measuring tube. No special measures need to be taken for fluids which have properties similar to water under normal conditions.</p> <p>In the case of liquids with a low boiling point (hydrocarbons, solvents, liquefied gases) or in suction lines, it is important to ensure that pressure does not drop below the vapor pressure and that the liquid does not start to boil. It is also important to ensure that the gases that occur naturally in many liquids do not outgas. Such effects can be prevented when system pressure is sufficiently high.</p> <p>Therefore, the following locations should be preferred for installation:</p> <ul style="list-style-type: none"> ■ Downstream from pumps (no danger of vacuum) ■ At the lowest point in a vertical pipe

Operating conditions: Environment

Ambient temperature range	<p>Optional: -20 to +60 °C (sensor, transmitter)</p> <p>Optional: -40 to +60 °C (sensor, transmitter)</p> <p>Note!</p> <ul style="list-style-type: none"> ■ Install the device at a shady location. Avoid direct sunlight, particularly in warm climatic regions. ■ At ambient temperatures below -20 °C the readability of the display may be impaired.
Storage temperature	-40 to +80 °C (preferably +20 °C)
Degree of protection	Standard: IP 67 (NEMA 4X) for transmitter and sensor
Shock resistance	According to IEC 68-2-31
Vibration resistance	Acceleration up to 1 g, 10 to 150 Hz, following IEC 68-2-6
Electromagnetic compatibility (EMC)	As per EN 61326/A1 (IEC 1326) and NAMUR recommendation NE 21

Operating conditions: Process

Medium temperature range

Sensor

Promass H:

–50 to +200 °C

Promass I:

–50 to +150 °C

Medium pressure range (nominal pressure)

Flanges:

Promass H:
DIN PN 40 / ANSI Cl 150, Cl 300 / JIS 10K, 20K

Promass I:
DIN PN 40 to 100 / ANSI Cl 150, Cl 300, Cl 600 / JIS 10K, 20K, 40K, 63K

Pressure ranges of secondary containment:

Promass H:

DN 8 to 15: 25 bar or 375 psi; DN 25 to 50: 16 bar or 250 psi

Promass I:

40 bar or 600 psi

Warning!

In case a danger of measuring tube failure exists due to process characteristics, e.g. with corrosive process fluids, we recommend the use of sensors whose secondary containment is equipped with special pressure monitoring connections (ordering option). With the help of these connections, fluid collected in the secondary containment in the event of tube failure can be bled off. This is especially important in high pressure gas applications. These connections can also be used for gas purging (gas detection). Dimensions → Page 24 ff.

Limiting flow

See information in the “Measuring range” Section on → Page 5

Select nominal diameter by optimizing between required flow range and permissible pressure loss. See the “Measuring range” section for a list of maximum possible full scale values.

- The minimum recommended full scale value is approx. 1/20 of the max. full scale value.
- In most applications, 20 to 50% of the maximum full scale value can be considered ideal.
- Select a lower full scale value for abrasive substances such as fluids with entrained solids (flow velocity <1 m/s).
- For gas measurement the following rules apply:
 - Flow velocity in the measuring tubes should not be more than half the sonic velocity (0.5 Mach).
 - The maximum mass flow depends on the density of the gas: formula → Page 5

Pressure loss

Pressure loss depends on the fluid properties and on the flow rate. The following formulae can be used to approximately calculate the pressure loss:

Reynolds number	$Re = \frac{4 \cdot m}{\pi \cdot d \cdot v \cdot \rho}$	a0003381
$Re \geq 2300^{1)}$	$\Delta p = K \cdot v^{0.25} \cdot m^{1.75} \cdot \rho^{-0.75} \cdot \frac{K3 \cdot m^2}{\rho}$	a0004631
$Re < 2300$	$\Delta p = K1 \cdot v \cdot m + \frac{K3 \cdot m^2}{\rho}$	a0004633
Δp = pressure loss [mbar] ρ = fluid density [kg/m ³] v = kinematic viscosity [m ² /s] d = inside diameter of measuring tubes [m] m = mass flow [kg/s] K to $K3$ = constants (depending on nominal diameter) ¹⁾ To compute the pressure loss for gases, always use the formula for $Re \geq 2300$.		

Pressure loss coefficients for Promass H

DN	d [m]	K	K1	K3
8	$8.51 \cdot 10^{-3}$	$8.04 \cdot 10^6$	$3.28 \cdot 10^7$	$1.15 \cdot 10^6$
15	$12.00 \cdot 10^{-3}$	$1.81 \cdot 10^6$	$9.99 \cdot 10^6$	$1.87 \cdot 10^5$
25	$17.60 \cdot 10^{-3}$	$3.67 \cdot 10^5$	$2.76 \cdot 10^6$	$4.99 \cdot 10^4$
40	$25.50 \cdot 10^{-3}$	$8.75 \cdot 10^4$	$8.67 \cdot 10^5$	$1.22 \cdot 10^4$
50	$40.50 \cdot 10^{-3}$	$1.35 \cdot 10^4$	$1.72 \cdot 10^5$	$1.20 \cdot 10^3$

Pressure loss data includes interface between measuring tube and piping

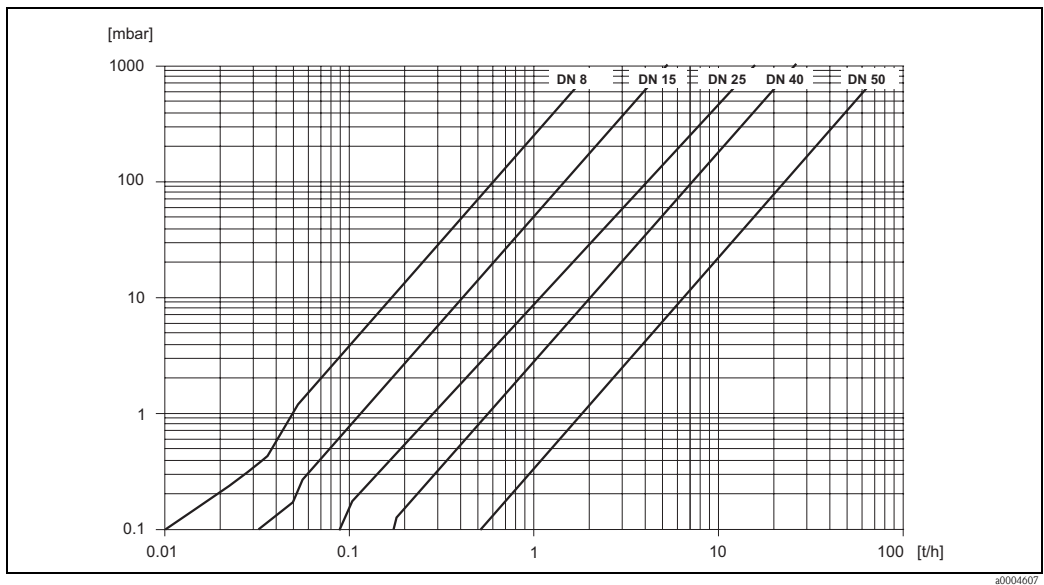

Pressure loss diagram for water

Pressure loss coefficients for Promass I

DN	d [m]	K	K1	K3
8	$8.55 \cdot 10^{-3}$	$8.1 \cdot 10^6$	$3.9 \cdot 10^7$	$129.95 \cdot 10^4$
15	$11.38 \cdot 10^{-3}$	$2.3 \cdot 10^6$	$1.3 \cdot 10^7$	$23.33 \cdot 10^4$
15 ¹⁾	$17.07 \cdot 10^{-3}$	$4.1 \cdot 10^5$	$3.3 \cdot 10^6$	$0.01 \cdot 10^4$
25	$17.07 \cdot 10^{-3}$	$4.1 \cdot 10^5$	$3.3 \cdot 10^6$	$5.89 \cdot 10^4$
25 ¹⁾	$25.60 \cdot 10^{-3}$	$7.8 \cdot 10^4$	$8.5 \cdot 10^5$	$0.11 \cdot 10^4$
40	$25.60 \cdot 10^{-3}$	$7.8 \cdot 10^4$	$8.5 \cdot 10^5$	$1.19 \cdot 10^4$
40 ¹⁾	$35.62 \cdot 10^{-3}$	$1.3 \cdot 10^4$	$2.0 \cdot 10^5$	$0.08 \cdot 10^4$
50	$35.62 \cdot 10^{-3}$	$1.3 \cdot 10^4$	$2.0 \cdot 10^5$	$0.25 \cdot 10^4$
50 ¹⁾	$54.8 \cdot 10^{-3}$	$2.3 \cdot 10^3$	$5.5 \cdot 10^4$	$1.0 \cdot 10^2$
80	$54.8 \cdot 10^{-3}$	$2.3 \cdot 10^3$	$5.5 \cdot 10^4$	$3.5 \cdot 10^2$

Pressure loss data includes interface between measuring tube and piping
¹⁾DN 15, 25, 40, 50 "FB" = Full bore versions of Promass I

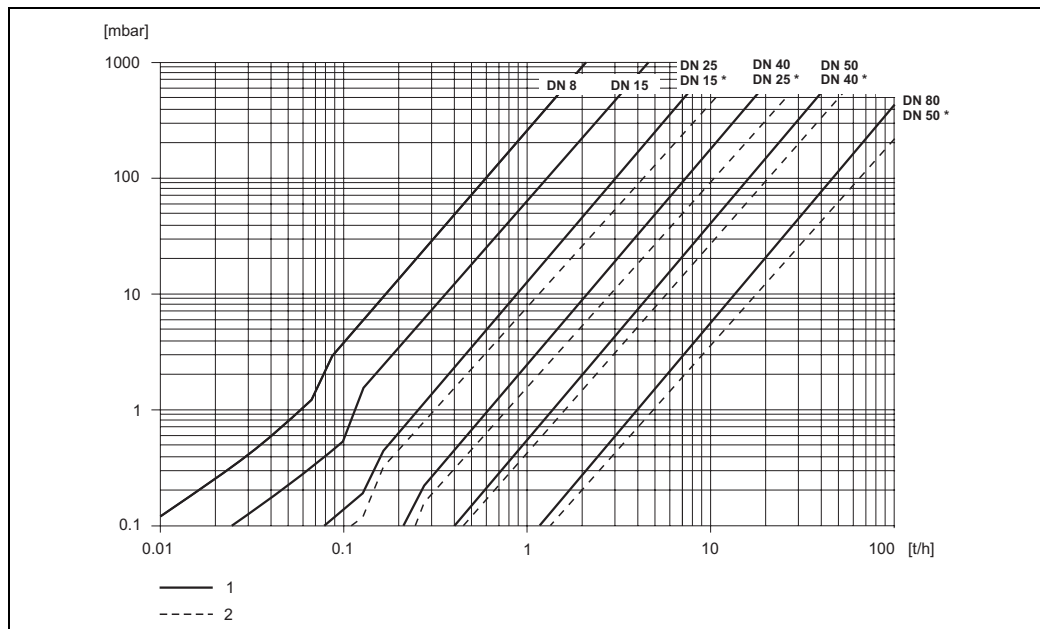

Pressure loss diagram for water

- 1 Standard versions
- 2 Full bore versions (*)

Mechanical construction

Design, dimensions

Dimensions: Wall-mount housing (non hazardous area and II3G / zone 2)

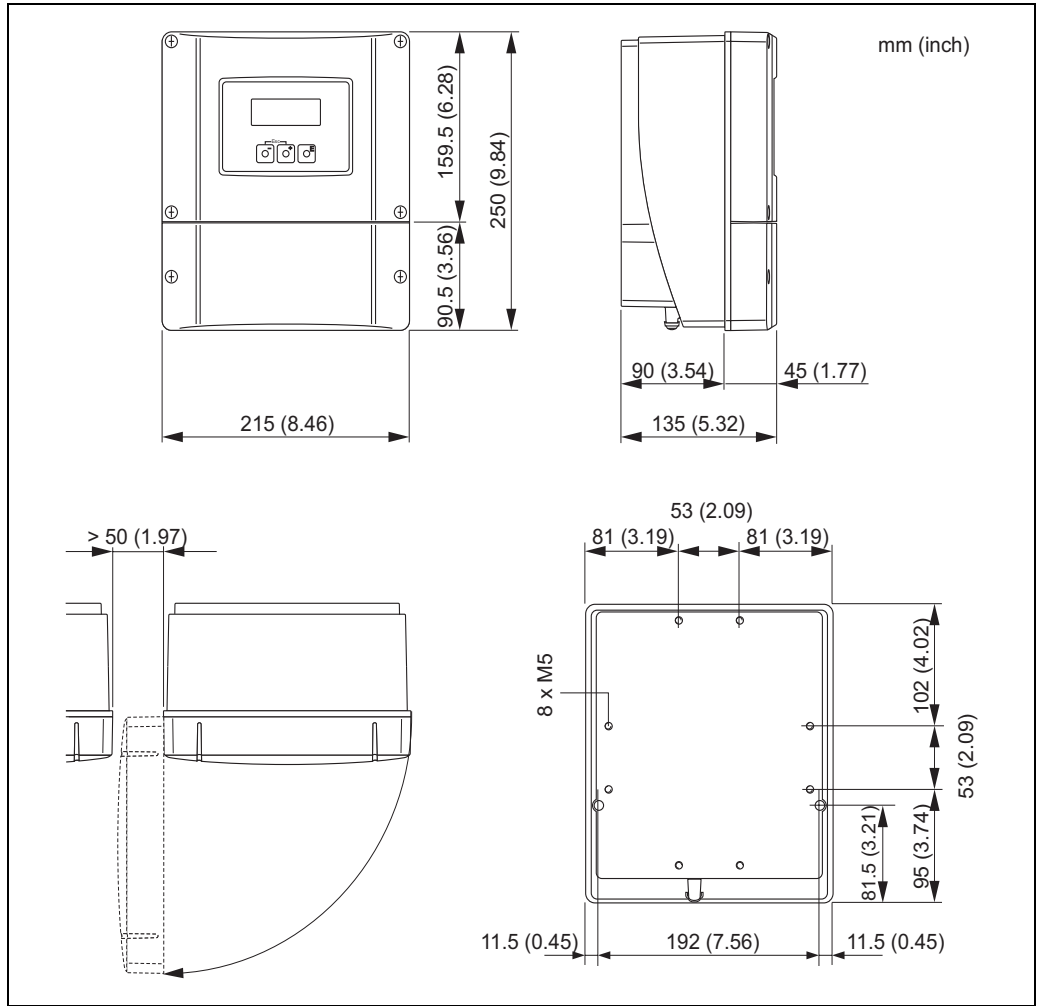

a0001150

Dimensions: Remote field housing (II2G / zone 1)

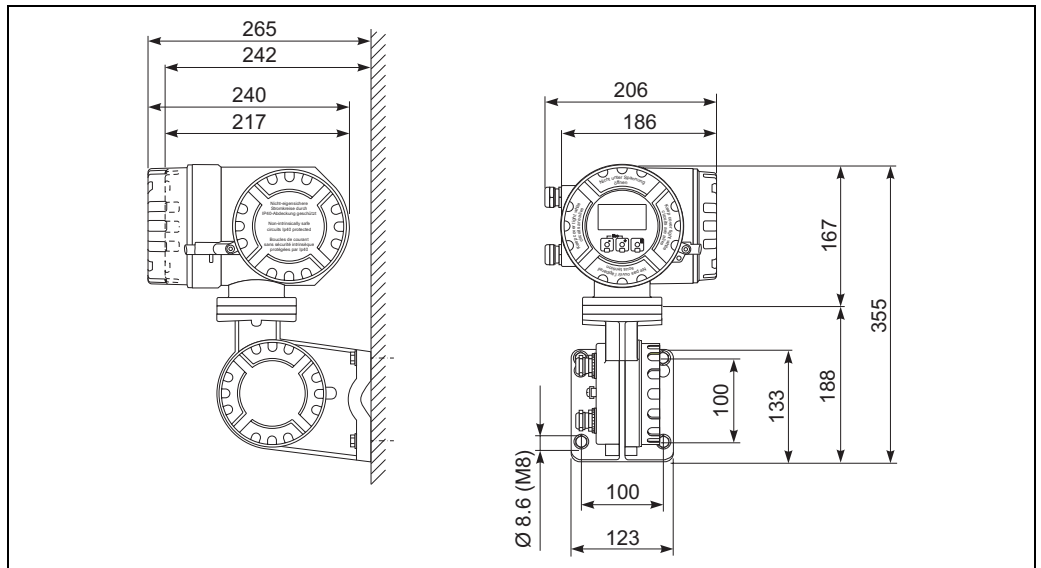

a0002128

Dimensions: stainless steel field housing

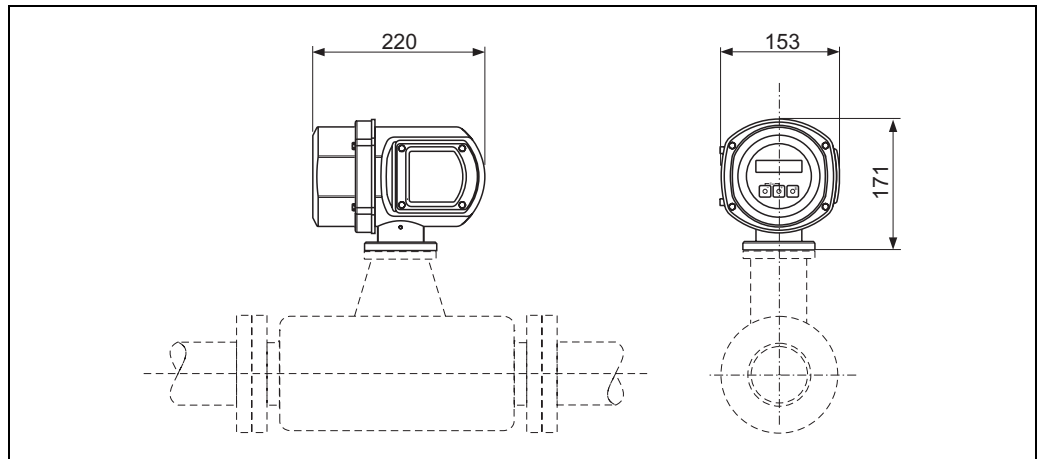

a0002245

Dimensions: stainless steel field housing

Dimensions: Remote version

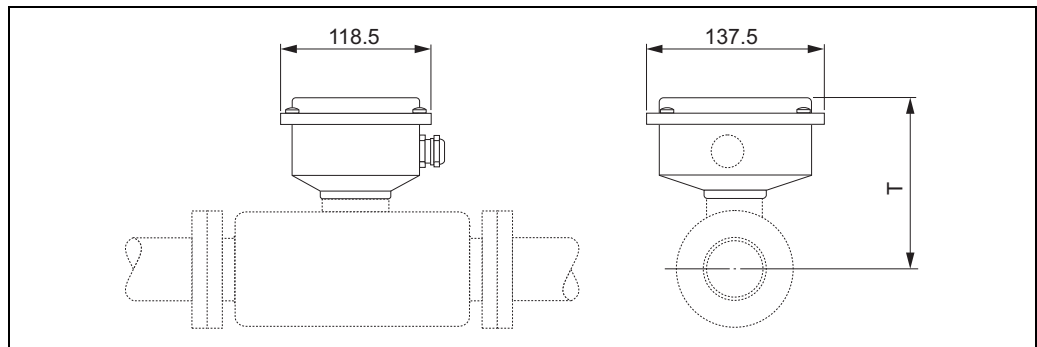

a0002516

T = dimension B in the compact version (with corresponding nominal diameter) minus 153 mm

Dimensions Promass H: Flange connections EN (DIN), ANSI, JIS

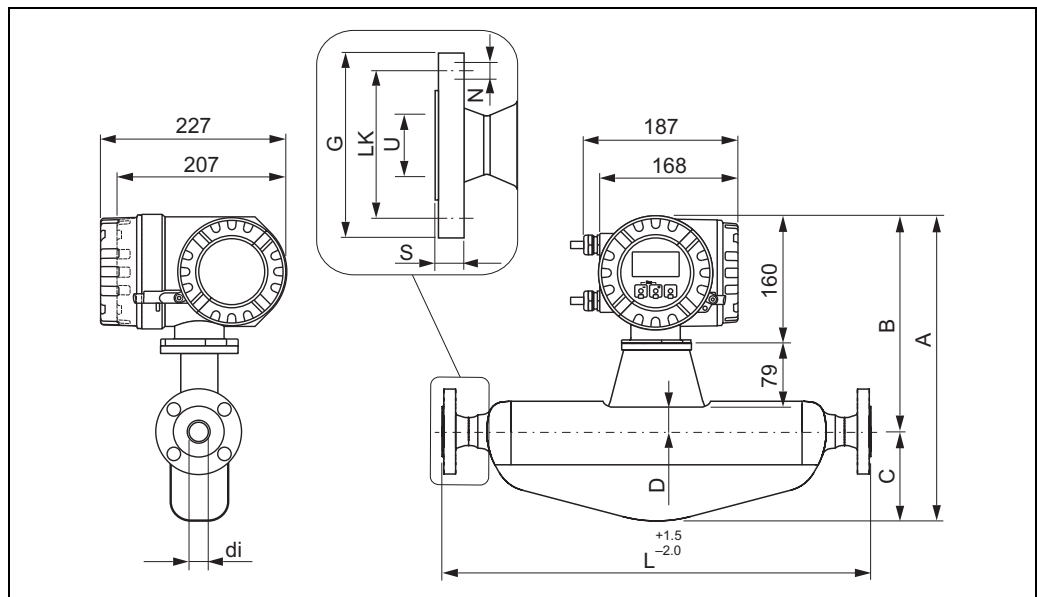

a0003287

Flange EN 1092-1 (DIN 2501 / DIN 2512N ¹⁾) / PN 40: 1.4301/304, fluid wetted parts: zirconium 702
 Surface roughness (flange): EN 1092-1 Form B1 (DIN 2526 Form C), Ra 6.3 to 12.5 µm

DN	A	B	C	D	G	L	N	S	LK	U	di
8 ¹⁾	384	280	104	41	95	336	4 x Ø14	20	65	17.30	8.51
15	385	280	105	41	95	440	4 x Ø14	20	65	17.30	12.00
25	401	280	121	41	115	580	4 x Ø14	19	85	28.50	17.60
40	475	304	171	65	150	794	4 x Ø18	21.5	110	43.10	25.50
50	556	315	241	76	165	1071	4 x Ø18	23.5	125	54.50	40.50

¹⁾ DN 8 with DN 15 flanges as standard

Flange ANSI B16.5 / Cl 150: 1.4301/304, fluid wetted parts: zirconium 702
 Surface roughness (flange): Ra 3.2 to 6.3 µm

DN	A	B	C	D	G	L	N	S	LK	U	di
8 ¹⁾	3/8"	384	280	104	41	88.9	4 x Ø15.7	12.8	60.5	15.70	8.51
15	1/2"	385	280	105	41	88.9	4 x Ø15.7	12.8	60.5	15.70	12.00
25	1"	401	280	121	41	108.0	4 x Ø15.7	15.1	79.2	26.70	17.60
40	1 1/2"	475	304	171	65	127.0	4 x Ø15.7	17.5	98.6	40.90	25.50
50	2"	556	315	241	76	152.4	4 x Ø19.1	23.6	120.7	52.60	40.50

¹⁾ DN 8 with DN 15 flanges as standard

Flange ANSI B16.5 / Cl 300: 1.4301/304, fluid wetted parts: zirconium 702
 Surface roughness (flange): Ra 3.2 to 6.3 µm

DN	A	B	C	D	G	L	N	S	LK	U	di
8 ¹⁾	3/8"	384	280	104	41	95.2	4 x Ø15.7	14.2	66.5	15.70	8.51
15	1/2"	385	280	105	41	95.2	4 x Ø15.7	14.2	66.5	15.70	12.00
25	1"	401	280	121	41	124.0	4 x Ø19.1	17.5	88.9	26.70	17.60
40	1 1/2"	475	304	171	65	155.4	4 x Ø22.3	20.6	114.3	40.90	25.50
50	2"	556	315	241	76	165.1	8 x Ø19.1	23.6	127	52.60	40.50

¹⁾ DN 8 with DN 15 flanges as standard

Flange JIS B2238 / 20K: 1.4301/304, fluid wetted parts: zirconium 702
 Surface roughness (flange): Ra 3.2 to 6.3 µm

DN	A	B	C	D	G	L	N	S	LK	U	di
8 ¹⁾	384	280	104	41	95	336	4 x Ø15	14	70	15.00	8.51
15	385	280	105	41	95	440	4 x Ø15	14	70	15.00	12.00
25	401	280	121	41	125	580	4 x Ø19	16	90	25.00	17.60
40	475	304	171	65	140	794	4 x Ø19	18	105	40.00	25.50
50	556	315	241	76	165	1071	8 x Ø19	22	120	50.00	40.50

¹⁾ DN 8 with DN 15 flanges as standard

Dimensions Promass H: Purge connections / secondary containment monitoring**Caution!**

The secondary containment is filled with dry nitrogen (N_2). Do not open the purge connections unless the containment can be filled immediately with a dry inert gas. Use only low gauge pressure to purge. Maximum pressure: 5 bar.

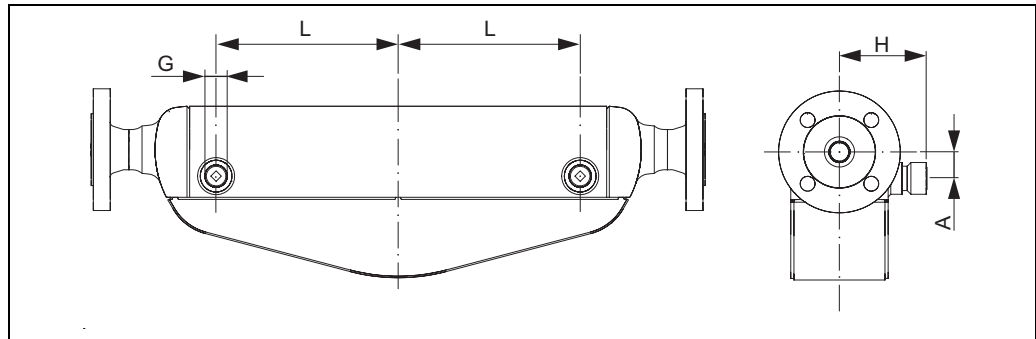

40003288

DN	L	H	A	G
8	55	82	25	1/2" NPT
15	102	82	25	1/2" NPT
25	172	82	25	1/2" NPT
40	263	102	45	1/2" NPT
50	381.5	119.5	58	1/2" NPT

Dimensions Promass I: Flange connections EN (DIN), ANSI, JIS

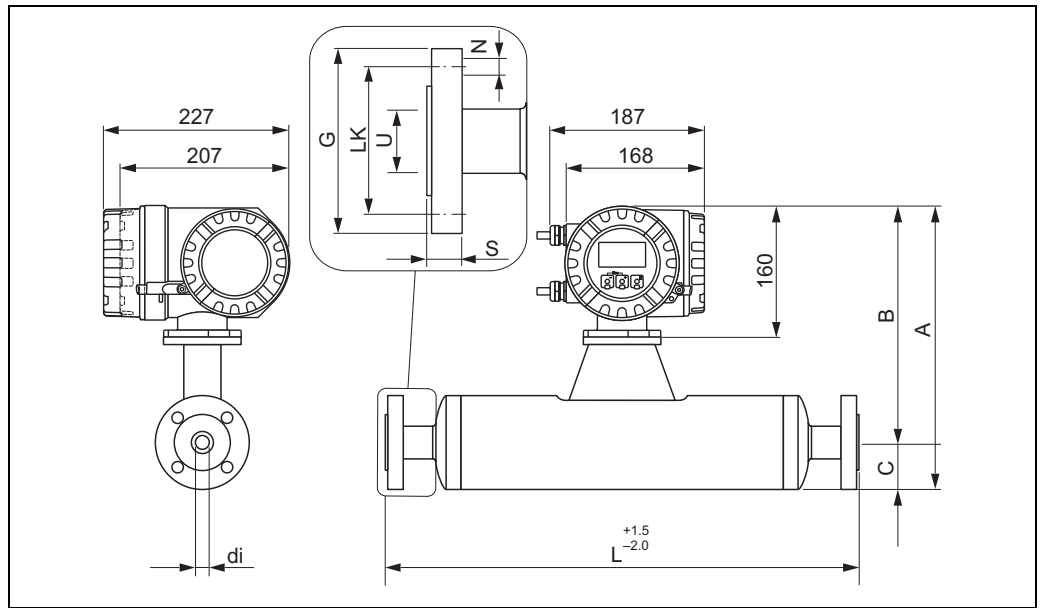

a0003313

Flange EN 1092-1 (DIN 2501) / PN 40: 1.4301/304, fluid wetted parts: titanium

Surface roughness (flange): EN 1092-1 Form B1 (DIN 2526 Form C), Ra 6.3 to 12.5 µm

DN	A	B	C	G	L	N	S	LK	U	di
8 ¹⁾	350	291	59	95	402	4 x Ø14	20	65	17.30	8.55
15	350	291	59	95	438	4 x Ø14	20	65	17.30	11.38
15 ²⁾	350	291	59	95	572	4 x Ø14	19	65	17.07	17.07
25	350	291	59	115	578	4 x Ø14	23	85	28.50	17.07
25 ²⁾	377	305	72	115	700	4 x Ø14	22	85	25.60	25.60
40	377	305	72	150	708	4 x Ø18	26	110	43.10	25.60
40 ²⁾	406	320	86	150	819	4 x Ø18	24	110	35.62	35.62
50	406	320	86	165	827	4 x Ø18	28	125	54.50	35.62
50 ²⁾	458.1	349	110	165	1210	4 x Ø18	40	125	54.8	54.8
80	458.1	349	110	200	1210	8 x Ø18	37	160	82.5	54.8

¹⁾ DN 8 with DN 15 flanges as standard

²⁾ DN 15, 25, 40, 50 "FB" = Full bore versions of Promass I

Flange EN 1092-1 (DIN 2501) / PN 63: 1.4301/304, fluid wetted parts: titanium

Surface roughness (flange): EN 1092-1 Form B2 (DIN 2526 Form E), Ra 1.6 to 3.2 µm

DN	A	B	C	G	L	N	S	LK	U	di
50	406	320	86	180	832	4 x Ø22	34	135	54.5	35.62
50 ¹⁾	458.1	349	110	180	1210	4 x Ø22	45	135	54.8	54.8
80	458.1	349	110	215	1210	8 x Ø22	41	170	81.7	54.8

¹⁾ DN 15, 25, 40, 50 "FB" = Full bore versions of Promass I

Flange EN 1092-1 (DIN 2501) / PN 100: 1.4301/304, fluid wetted parts: titanium										
Surface roughness (flange): EN 1092-1 Form B2 (DIN 2526 Form E), Ra 1.6 to 3.2 µm										
DN	A	B	C	G	L	N	S	LK	U	di
8 ¹⁾	350	291	59	105	402	4 x Ø14	25	75	17.30	8.55
15	350	291	59	105	438	4 x Ø14	25	75	17.30	11.38
15 ²⁾	350	291	59	105	578	4 x Ø14	26	75	17.07	17.07
25	350	291	59	140	578	4 x Ø18	29	100	28.50	17.07
25 ²⁾	377	305	72	140	706	4 x Ø18	31	100	25.60	25.60
40	377	305	72	170	708	4 x Ø22	32	125	42.50	25.60
40 ²⁾	406	320	86	170	825	4 x Ø22	33	125	35.62	35.62
50	406	320	86	195	832	4 x Ø26	36	145	53.90	35.62
50 ²⁾	458.1	349	110	195	1210	4 x Ø26	48	145	54.8	54.8
80	458.1	349	110	230	1236	8 x Ø26	58	180	80.9	54.8

¹⁾ DN 8 with DN 15 flanges as standard
²⁾ DN 15, 25, 40, 50 "FB" = Full bore versions of Promass I

Flange ANSI B16.5 / CI 150: 1.4301/304, fluid wetted parts: titanium											
Surface roughness (flange): Ra 3.2 to 6.3 µm											
DN	A	B	C	G	L	N	S	LK	U	di	
8 ¹⁾	3/8"	350	291	59	88.9	402	4 x Ø15.7	20	60.5	15.70	8.55
15	1/2"	350	291	59	88.9	438	4 x Ø15.7	20	60.5	15.70	11.38
15 ²⁾	1/2"	350	291	59	88.9	572	4 x Ø15.7	19	60.5	17.07	17.07
25	1"	350	291	59	108.0	578	4 x Ø15.7	23	79.2	26.70	17.07
25 ²⁾	1"	377	305	72	108.0	700	4 x Ø15.7	22	79.2	25.60	25.60
40	1 1/2"	377	305	72	127.0	708	4 x Ø15.7	26	98.6	40.90	25.60
40 ²⁾	1 1/2"	406	320	86	127.0	819	4 x Ø15.7	24	98.6	35.62	35.62
50	2"	406	320	86	152.4	827	4 x Ø19.1	28	120.7	52.60	35.62
50 ²⁾	2"	458.1	349	110	152.4	1210	4 x Ø19.1	40	120.7	54.8	54.8
80	3"	458.1	349	110	190.5	1210	4 x Ø19.1	37	152.4	78	54.8

¹⁾ DN 8 with DN 15 flanges as standard
²⁾ DN 15, 25, 40, 50 "FB" = Full bore versions of Promass I

Flange ANSI B16.5 / CI 300: 1.4301/304, fluid wetted parts: titanium											
Surface roughness (flange): Ra 3.2 to 6.3 µm											
DN		A	B	C	G	L	N	S	LK	U	di
8 ¹⁾	3/8"	350	291	59	95.3	402	4 x Ø15.7	20	66.5	15.70	8.55
15	1/2"	350	291	59	95.3	438	4 x Ø15.7	20	66.5	15.70	11.38
15 ²⁾	1/2"	350	291	59	95.3	572	4 x Ø15.7	19	66.5	17.07	17.07
25	1"	350	291	59	124.0	578	4 x Ø19.1	23	88.9	26.70	17.07
25 ²⁾	1"	377	305	72	124.0	700	4 x Ø19.1	22	88.9	25.60	25.60
40	1 1/2"	377	305	72	155.4	708	4 x Ø22.4	26	114.3	40.90	25.60
40 ²⁾	1 1/2"	406	320	86	155.4	819	4 x Ø22.4	24	114.3	35.62	35.62
50	2"	406	320	86	165.1	827	8 x Ø19.1	28	127.0	52.60	35.62
50 ²⁾	2"	458.1	349	110	165.1	1210	8 x Ø19.1	43	127	54.8	54.8
80	3"	458.1	349	110	209.5	1210	8 x Ø22.3	42	168.1	78	54.8

¹⁾ DN 8 with DN 15 flanges as standard
²⁾ DN 15, 25, 40, 50 "FB" = Full bore versions of Promass I

Flange ANSI B16.5 / CI 600: 1.4301/304, fluid wetted parts: titanium											
Surface roughness (flange): Ra 3.2 to 6.3 µm											
DN		A	B	C	G	L	N	S	LK	U	di
8 ¹⁾	3/8"	350	291	59	95.3	402	4 x Ø15.7	20	66.5	13.80	8.55
15	1/2"	350	291	59	95.3	438	4 x Ø15.7	20	66.5	13.80	11.38
15 ²⁾	1/2"	350	291	59	95.3	578	4 x Ø15.7	22	66.5	17.07	17.07
25	1"	350	291	59	124.0	578	4 x Ø19.1	23	88.9	24.40	17.07
25 ²⁾	1"	377	305	72	124.0	706	4 x Ø19.1	25	88.9	25.60	25.60
40	1 1/2"	377	305	72	155.4	708	4 x Ø22.4	28	114.3	38.10	25.60
40 ²⁾	1 1/2"	406	320	86	155.4	825	4 x Ø22.4	29	114.3	35.62	35.62
50	2"	406	320	86	165.1	832	8 x Ø19.1	33	127.0	49.30	35.62
50 ²⁾	2"	458.1	349	110	165.1	1210	8 x Ø19.1	46	127	54.8	54.8
80	3"	458.1	349	110	209.5	1222	8 x Ø22.3	53	168.1	73.7	54.8

¹⁾ DN 8 with DN 15 flanges as standard
²⁾ DN 15, 25, 40, 50 "FB" = Full bore versions of Promass I

Flange JIS B2238 / 10K: 1.4301/304, fluid wetted parts: titanium											
Surface roughness (flange): Ra 3.2 to 6.3 µm											
DN		A	B	C	G	L	N	S	LK	U	di
50		406	320	86	155	827	4 x Ø19	28	120	50	35.62
50 ¹⁾		458.1	349	110	155	1210	4 x Ø19	40	120	54.8	54.8
80		458.1	349	110	185	1210	8 x Ø19	33	150	80	54.8

¹⁾ DN 15, 25, 40, 50 "FB" = Full bore versions of Promass I

Flange JIS B2238 / 20K: 1.4301/304, fluid wetted parts: titanium										
Surface roughness (flange): Ra 3.2 to 6.3 μm										
DN	A	B	C	G	L	N	S	LK	U	di
8 ¹⁾	350	291	59	95	402	4 x \varnothing 15	20	70	15.00	8.55
15	350	291	59	95	438	4 x \varnothing 15	20	70	15.00	11.38
15 ²⁾	350	291	59	95	572	4 x \varnothing 15	19	70	17.07	17.07
25	350	291	59	125	578	4 x \varnothing 19	23	90	25.00	17.07
25 ²⁾	377	305	72	125	700	4 x \varnothing 19	22	90	25.60	25.60
40	377	305	72	140	708	4 x \varnothing 19	26	105	40.00	25.60
40 ²⁾	406	320	86	140	819	4 x \varnothing 19	24	105	35.62	35.62
50	406	320	86	155	827	8 x \varnothing 19	28	120	50.00	35.62
50 ²⁾	458.1	349	110	155	1210	8 x \varnothing 19	42	120	54.8	54.8
80	458.1	349	110	200	1210	8 x \varnothing 23	36	160	80	54.8

¹⁾ DN 8 with DN 15 flanges as standard
²⁾ DN 15, 25, 40, 50 "FB" = Full bore versions of Promass I

Flange JIS B2238 / 40K: 1.4301/304, fluid wetted parts: titanium										
Surface roughness (flange): Ra 3.2 to 6.3 μm										
DN	A	B	C	G	L	N	S	LK	U	di
8 ¹⁾	350	291	59	115	402	4 x \varnothing 19	25	80	15.00	8.55
15	350	291	59	115	438	4 x \varnothing 19	25	80	15.00	11.38
15 ²⁾	350	291	59	115	578	4 x \varnothing 19	26	80	17.07	17.07
25	350	291	59	130	578	4 x \varnothing 19	27	95	25.00	17.07
25 ²⁾	377	305	72	130	706	4 x \varnothing 19	29	95	25.60	25.60
40	377	305	72	160	708	4 x \varnothing 23	30	120	38.00	25.60
40 ²⁾	406	320	86	160	825	4 x \varnothing 23	31	120	35.62	35.62
50	406	320	86	165	827	8 x \varnothing 19	32	130	50.00	35.62
50 ²⁾	458.1	349	110	165	1210	8 x \varnothing 19	43	130	54.8	54.8
80	458.1	349	110	210	1210	8 x \varnothing 23	46	170	75	54.8

¹⁾ DN 8 with DN 15 flanges as standard
²⁾ DN 15, 25, 40, 50 "FB" = Full bore versions of Promass I

Flange JIS B2238 / 63K: 1.4301/304, fluid wetted parts: titanium										
Surface roughness (flange): Ra 3.2 to 6.3 µm										
DN	A	B	C	G	L	N	S	LK	U	di
8 ¹⁾	350	291	59	120	402	4 x Ø19	28	85	12.00	8.55
15	350	291	59	120	438	4 x Ø19	28	85	12.80	11.38
15 ²⁾	350	291	59	120	578	4 x Ø19	29	85	17.07	17.07
25	350	291	59	140	578	4 x Ø23	30	100	22.00	17.07
25 ²⁾	377	305	72	140	706	4 x Ø23	32	100	25.60	25.60
40	377	305	72	175	708	4 x Ø25	36	130	35.00	25.60
40 ²⁾	406	320	86	175	825	4 x Ø25	37	130	35.62	35.62
50	406	320	86	185	832	8 x Ø23	40	145	48.00	35.62
50 ²⁾	458.1	349	110	185	1210	8 x Ø23	47	145	54.8	54.8
80	458.1	349	110	230	1226	8 x Ø25	55	185	73	54.8

¹⁾ DN 8 with DN 15 flanges as standard
²⁾ DN 15, 25, 40, 50 "FB" = Full bore versions of Promass I

Dimensions Promass I: Tri-Clamp connections

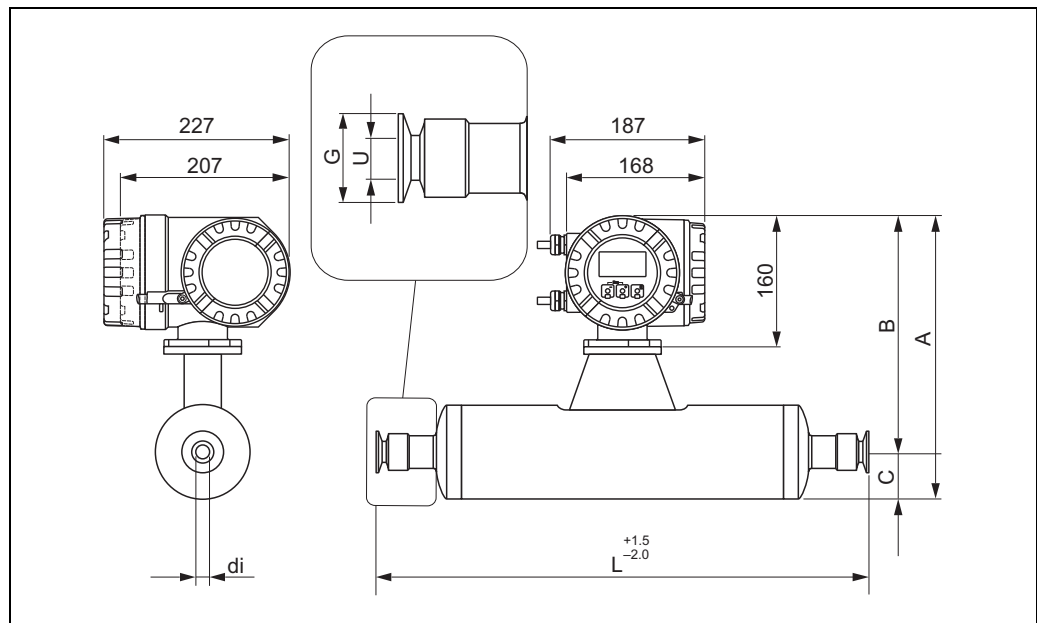

Tri-Clamp / 3A version ¹⁾ : titanium								
DN	Clamp	A	B	C	G	L	U	di
8	1"	350	291	59	50.4	427	22.1	8.55
15	1"	350	291	59	50.4	463	22.1	11.38
15 ²⁾	see 3/4" Tri-Clamp connection							
25	1"	350	291	59	50.4	603	22.1	17.07
25 ²⁾	1"	377	305	72	50.4	730	22.1	25.60
40	1 1/2"	377	305	72	50.4	731	34.8	25.60
40 ²⁾	1 1/2"	406	320	86	50.4	849	34.8	35.62
50	2"	406	320	86	63.9	850	47.5	35.62
50 ²⁾	2 1/2"	458.1	349	110	77.4	1268	60.3	54.8
80	3"	458.1	349	110	90.9	1268	72.9	54.8
¹⁾ 3A version (Ra ≤ 0.8 μm/150 grit) Optional: Ra ≤ 0.4 m/240 grit)								
²⁾ DN 15, 25, 40, 50 "FB" = Full bore versions of Promass I								

1/2" Tri-Clamp / 3A version ¹⁾ : titanium								
DN	Clamp	A	B	C	G	L	U	di
8	1/2"	350	291	59	25.0	426	9.5	8.55
15	1/2"	350	291	59	25.0	462	9.5	11.38
¹⁾ 3A version (Ra ≤ 0.8 μm/150 grit) Optional: Ra ≤ 0.4 m/240 grit)								

3/4" Tri-Clamp / 3A version ¹⁾ : titanium								
DN	Clamp	A	B	C	G	L	U	di
8	3/4"	350	291	59	25.0	426	16.0	8.55
15	3/4"	350	291	59	25.0	462	16.0	11.38
15 ²⁾	3/4"	350	291	59	25.0	602	16.0	17.07

¹⁾ 3A version (Ra ≤ 0.8 μm/150 grit) Optional: Ra ≤ 0.4 μm/240 grit)
²⁾ DN 15 "FB" = Full bore versions of Promass I

Dimensions Promass I: DIN 11851 connections (sanitary connection)

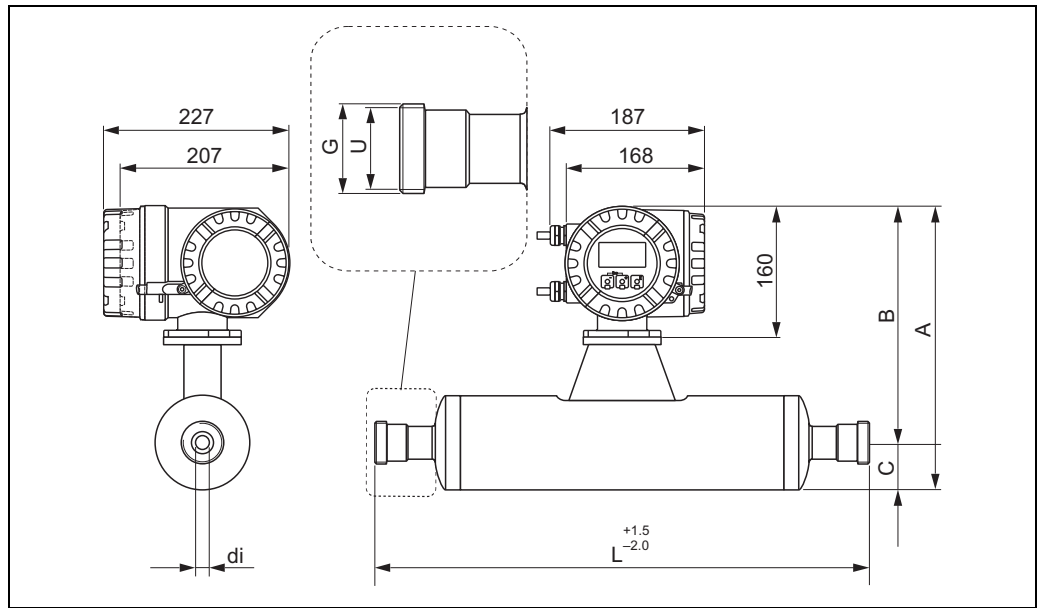

DIN 11851 sanitary connection / 3A version ¹⁾ : titanium							
DN	A	B	C	G	L	U	di
8	350	291	59	Rd 34 x 1/8"	427	16	8.55
15	350	291	59	Rd 34 x 1/8"	463	16	11.38
15 ²⁾	350	291	59	Rd 34 x 1/8"	602	16	17.07
25	350	291	59	Rd 52 x 1/6"	603	26	17.07
25 ²⁾	377	305	72	Rd 52 x 1/6"	736	26	25.60
40	377	305	72	Rd 65 x 1/6"	731	38	25.60
40 ²⁾	406	320	86	Rd 65 x 1/6"	855	38	35.62
50	406	320	86	Rd 78 x 1/6"	856	50	35.62
50 ²⁾	458.1	349	110	Rd 78 x 1/6"	1268	50	54.8
80	458.1	349	110	Rd 110 x 1/4"	1268	81	54.8

¹⁾ 3A version (Ra ≤ 0.8 μm/150 grit)
²⁾ DN 15, 25, 40, 50 "FB" = Full bore versions of Promass I

DIN 11851 Rd 28 x 1/8" sanitary connection / 3A version ¹⁾ : titanium							
DN	A	B	C	G	L	U	di
8	350	291	59	Rd 28x 1/8"	426	10	8.55
15	350	291	59	Rd 28x 1/8"	462	10	11.38

¹⁾ 3A version (Ra ≤ 0.8 μm/150 grit)

Dimensions Promass I: DIN 11864-1 Form A connections (couplings)

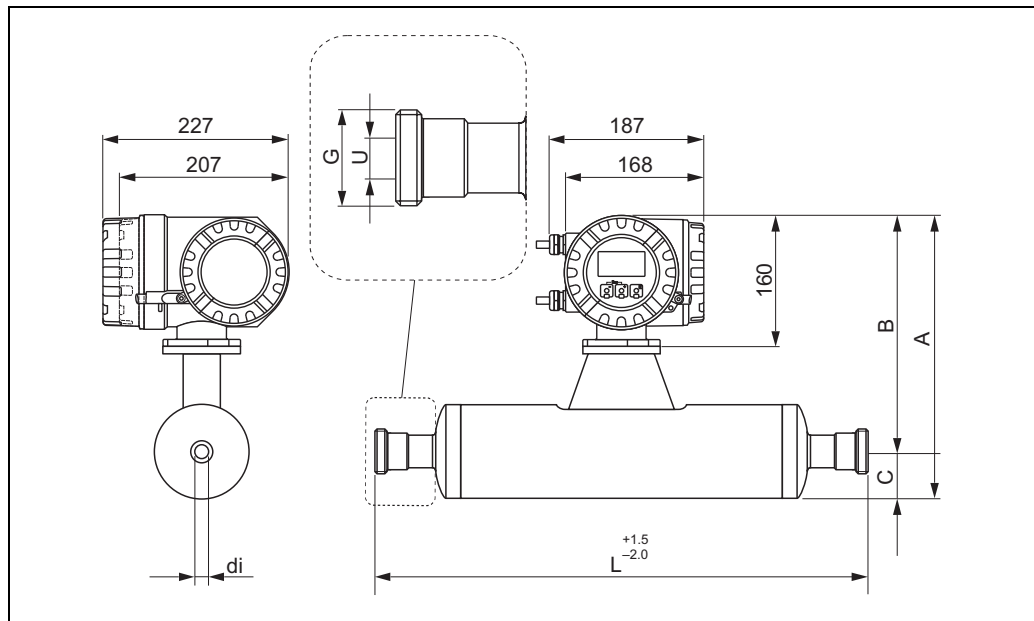

a0003317

DIN 11864 -1 Form A sanitary connection / 3A version ¹⁾ : titanium							
DN	A	B	C	G	L	U	di
8 ²⁾	350	291	59	Rd 28x 1/8"	428	10	8.55
15	350	291	59	Rd 34 x 1/8"	463	16	11.38
15 ³⁾	350	291	59	Rd 34 x 1/8"	602	16	17.07
25	350	291	59	Rd 52 x 1/6"	603	26	17.07
25 ³⁾	377	305	72	Rd 52 x 1/6"	734	26	25.60
40	377	305	72	Rd 65 x 1/6"	731	38	25.60
40 ³⁾	406	320	86	Rd 65 x 1/6"	855	38	35.62
50	406	320	86	Rd 78 x 1/6"	856	50	35.62
50 ³⁾	458.1	349	110	Rd 78 x 1/6"	1268	50	54.8
80	458.1	349	110	Rd 110 x 1/4"	1268	81	54.8

¹⁾ 3A version (Ra ≤ 0.8 μm/150 grit) Optional: Ra ≤ 0.4 μm/240 grit)
²⁾ DN 8 with DN 10 threaded adapter
³⁾ DN 15, 25, 40, 50 "FB" = Full bore versions of Promass I

Dimensions Promass I: Flange connections DIN 11864-2 Form A (flat flange)

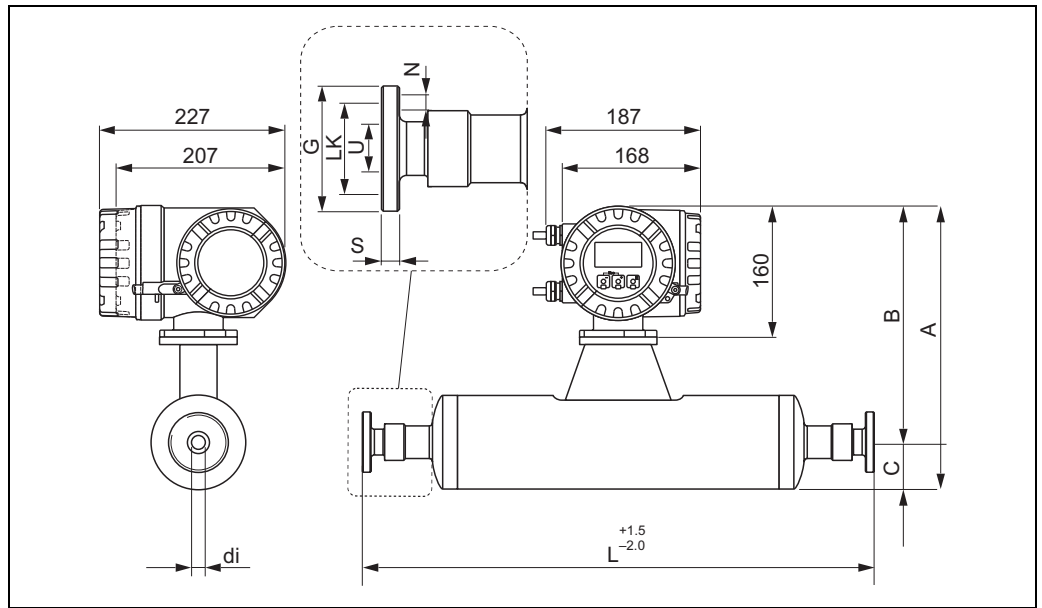

a0003318

Flange DIN 11864-2 Form A (flat flange) / 3A version ¹⁾ ; titanium										
DN	A	B	C	G	L	N	S	LK	U	di
8 ²⁾	350	291	59	54	449	4 x Ø9	10	37	10	8.55
15	350	291	59	59	485	4 x Ø9	10	42	16	11.38
25	350	291	59	70	625	4 x Ø9	10	53	26	17.07
40	377	305	72	82	753	4 x Ø9	10	65	38	25.60
50	406	320	86	94	874	4 x Ø9	10	77	50	35.62
50 ³⁾	458.1	349	110	94	1278	4 x Ø9	10	77	50	54.8
80	458.1	349	110	133	1268	4 x Ø11	12	97.7	81	54.8

¹⁾ 3A version (Ra ≤ 0.8 mm/150 grit) Optional: Ra ≤ 0.4 mm/240 grit)
²⁾ DN 8 with DN 10 threaded adapter
³⁾ DN 50 "FB" = Full bore versions of Promass I

Dimensions Promass I: ISO 2853 connections (couplings)

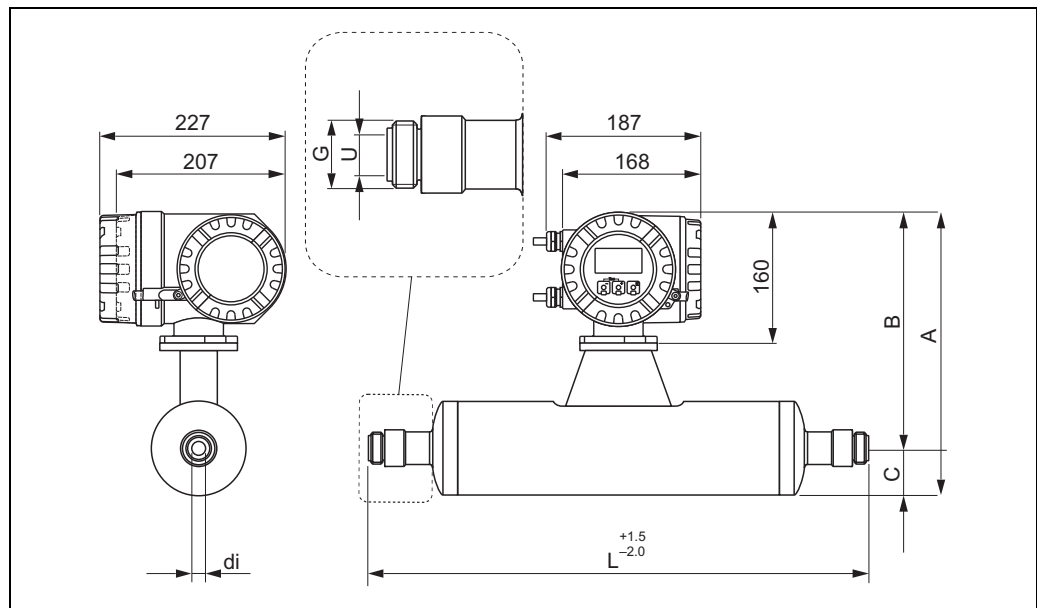

a0003319

ISO 2853 connection / 3A version ¹⁾ ; titanium							
DN	A	B	C	G	L	U	di
8 ²⁾	350	291	59	37.13	435	22.6	8.55
15	350	291	59	37.13	471	22.6	11.38
15 ³⁾	350	291	59	37.13	610	22.6	17.07
25 ³⁾	377	305	72	37.13	744	22.6	25.60
40	377	305	72	50.65	737	35.6	25.60
40 ³⁾	406	320	86	50.65	859	35.6	35.62
50	406	320	86	64.16	856	48.6	35.62
50 ³⁾	458.1	349	110	64.1	1268	48.6	54.8
80	458.1	349	110	91.19	1268	72.9	54.8

¹⁾ 3A version (Ra ≤ 0.8 μm/150 grit) Optional: Ra ≤ 0.4 μm/240 grit)
²⁾ DN 8 with DN 15 threaded adapters as standard
³⁾ DN 15, 25, 40, 50 "FB" = Full bore versions of Promass I

Dimensions Promass I: SMS 1145 connections (sanitary connection)

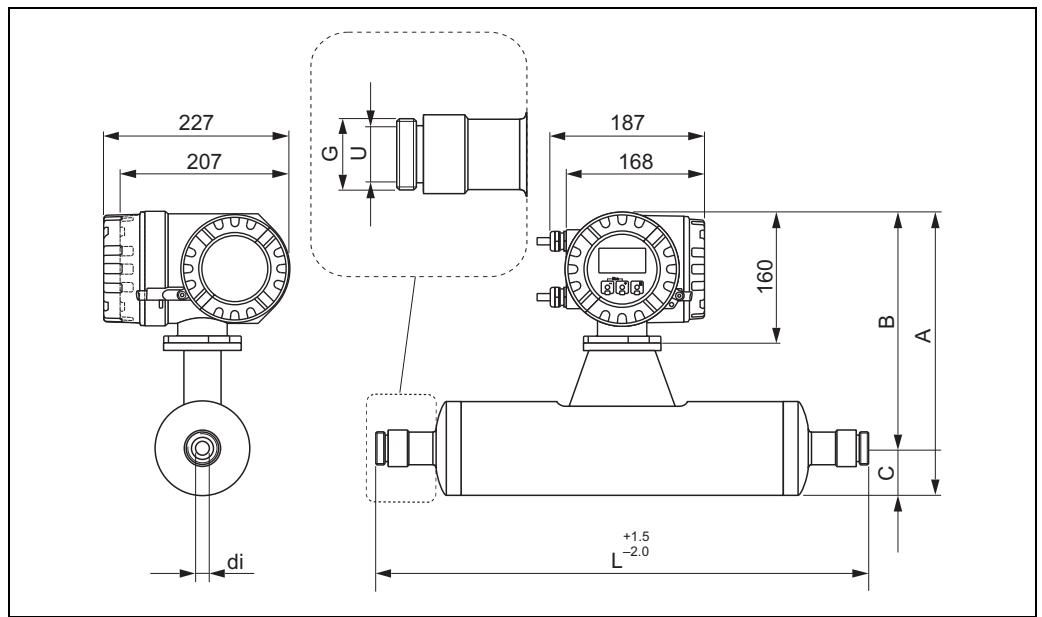

SMS 1145 sanitary connection / 3A version ¹⁾ : titanium							
DN	A	B	C	G	L	U	di
8	350	291	59	Rd 40 x 1/6"	427	22.5	8.55
15	350	291	59	Rd 40 x 1/6"	463	22.5	11.38
25	350	291	59	Rd 40 x 1/6"	603	22.5	17.07
25 ²⁾	377	305	72	Rd 40 x 1/6"	736	22.5	25.60
40	377	305	72	Rd 60 x 1/6"	738	35.5	25.60
40 ²⁾	406	320	86	Rd 60 x 1/6"	857	35.5	35.62
50	406	320	86	Rd 70 x 1/6"	858	48.5	35.62
50 ²⁾	458.1	349	110	Rd 70 x 1/6"	1258	48.5	54.8
80	458.1	349	110	Rd 98 x 1/6"	1268	72	54.8

¹⁾ 3A version (Ra ≤ 0.8 μm/150 grit)
²⁾ DN 15, 25, 40, 50 "FB" = Full bore versions of Promass I

Dimensions Promass I: Purge connections / secondary containment monitoring

Caution!

The secondary containment is filled with dry nitrogen (N₂). Do not open the purge connections unless the containment can be filled immediately with a dry inert gas. Use only low gauge pressure to purge. Maximum pressure: 5 bar.

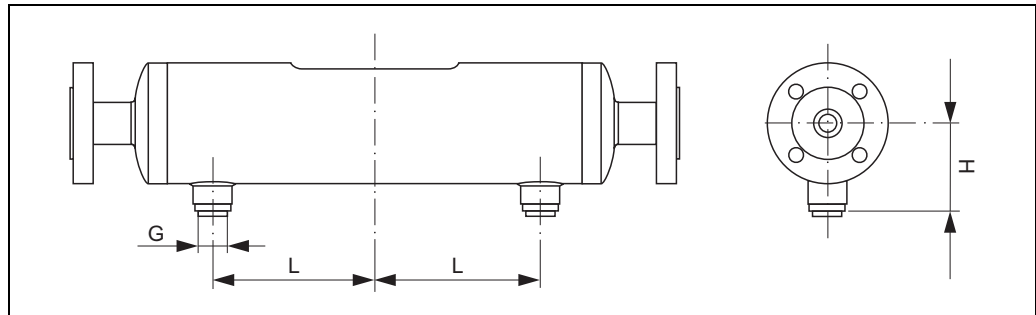

a0003321

DN	L	H	G
8 ¹⁾	61	90.65	1/2" NPT
15	79	90.65	1/2" NPT
15 ²⁾	79	90.65	1/2" NPT
25	148	90.65	1/2" NPT
25 ²⁾	148	90.65	1/2" NPT
40	196	103.35	1/2" NPT
40 ²⁾	196	103.35	1/2" NPT
50	244	117.75	1/2" NPT
50 ²⁾	407	145.5	1/2" NPT
80	407	145.5	1/2" NPT

¹⁾ DN 8 with DN 15 flanges as standard

²⁾ DN 15, 25, 40, 50 "FB" = Full bore versions of Promass I

Weight

- Compact version: see table below
- Remote version
 - Sensor: see table below
 - Wall-mount housing: 5 kg

Promass H / DN	8	15	25	40	50
Compact version	12	13	19	36	69
Remote version	10	11	17	34	67

Promass I / DN	8	15	15 ¹⁾	25	25 ¹⁾	40	40 ¹⁾	50	50 ¹⁾	80 ²⁾
Compact version	12	15	19	20	40	41	65	67	120	124
Remote version	10	13	17	18	38	39	63	65	118	122

¹⁾ DN 15, 25, 40, 50 "FB" = Full bore versions of Promass I

²⁾ Promass I only

Weight information in [kg].

All values (weight) refer to devices with EN/DIN PN 40 flanges.

Materials

Transmitter housing:

- Compact housing: stainless steel 1.4301/304
- Compact housing: powder coated die-cast aluminum
- Wall-mount housing: powder coated die-cast aluminum
- Remote field housing: powder-coated die-cast aluminum

Sensor housing / containment:

- Acid and alkali-resistant outer surface
- Stainless steel 1.4301/304

Connection housing, sensor (remote version):

- Stainless steel 1.4301/304

Process connections

Promass H:

- Flanges EN 1092-1 (DIN 2501) / ANSI B16.5 / JIS B2238 → stainless steel 1.4301/304, fluid wetted parts: zirconium 702

Promass I:

- Flanges EN 1092-1 (DIN 2501) / ANSI B16.5 / JIS B2238 → stainless steel 1.4301/304
- Flange DIN 11864-2 Form A (flat flange) → titanium grade 2
- Sanitary connection DIN 11851 / SMS 1145 → titanium grade 2
- Couplings ISO 2853 / DIN 11864-1 → titanium grade 2
- Tri-Clamp (OD-Tubes) → titanium grade 2

Measuring tubes:

Promass H:

- Zirconium 702/R 60702

Promass I:

- Titanium grade 9
- Titanium grade 2 (flange disks)

Seals:

Welded process connections without internal seals

Material load curves

Promass H: Flange connection to EN 1092-1 (DIN 2501)

Flange material: 1.4301/301

Fluid wetted parts: zirconium 702

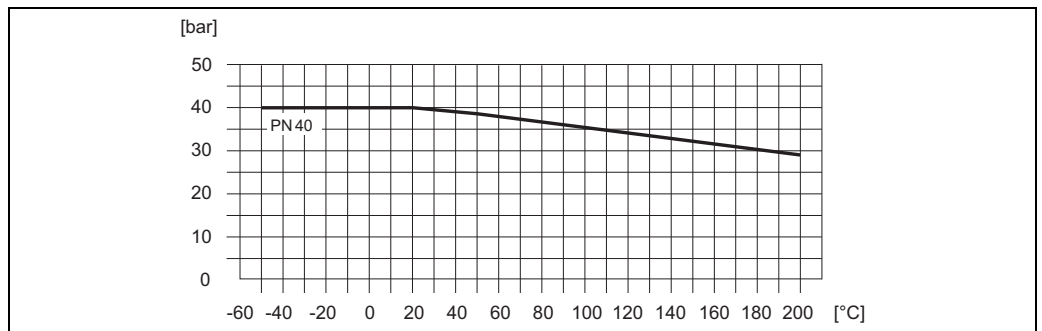

a0003289

Promass H: Flange connection to ANSI B16.5

Flange material: 1.4301/304
 Fluid wetted parts: zirconium 702

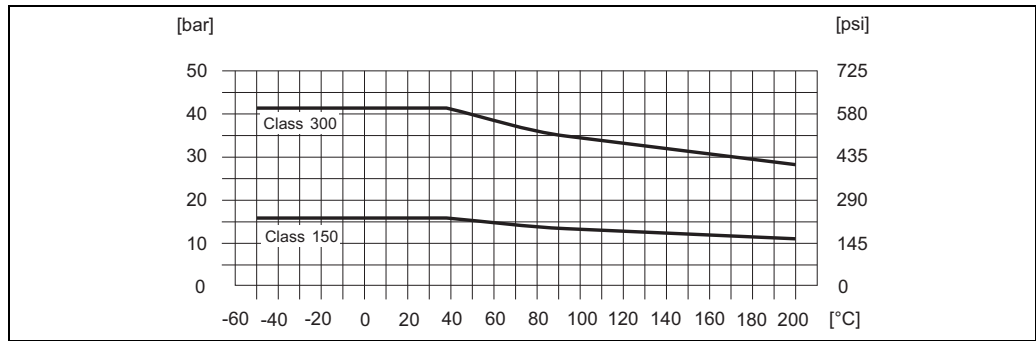

a0003290

Promass H: Flange connection to JIS B2238

Flange material: 1.4301/304
 Fluid wetted parts: zirconium 702

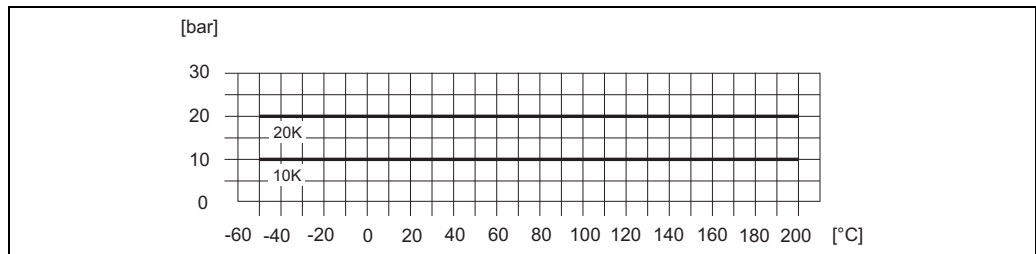

a0003324

Promass I: Flange connection to EN 1092-1 (DIN 2501)

Flange material: 1.4301/304
 Fluid wetted parts: titanium

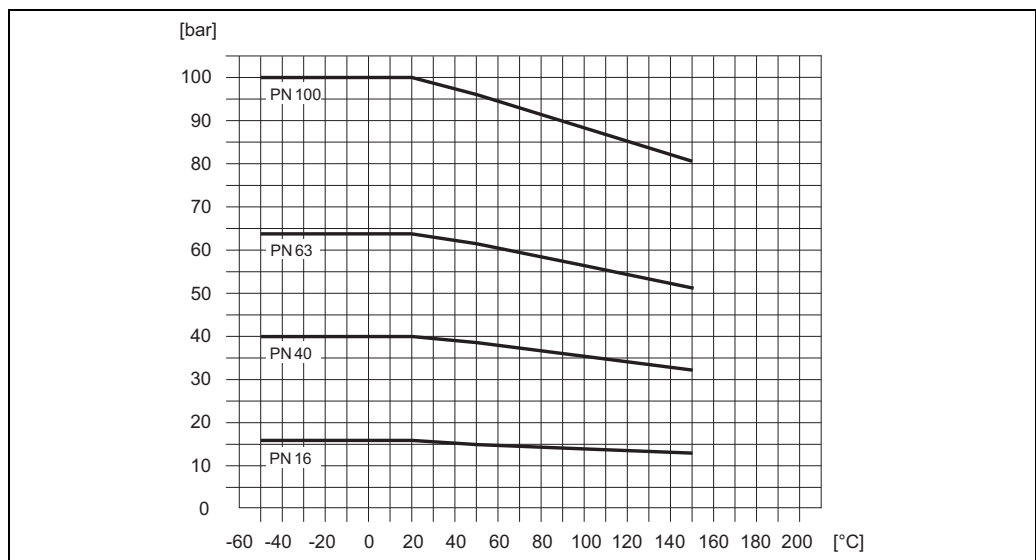

a0003293

Promass I: Flange connection to ANSI B16.5

Flange material: 1.4301/304
 Fluid wetted parts: titanium

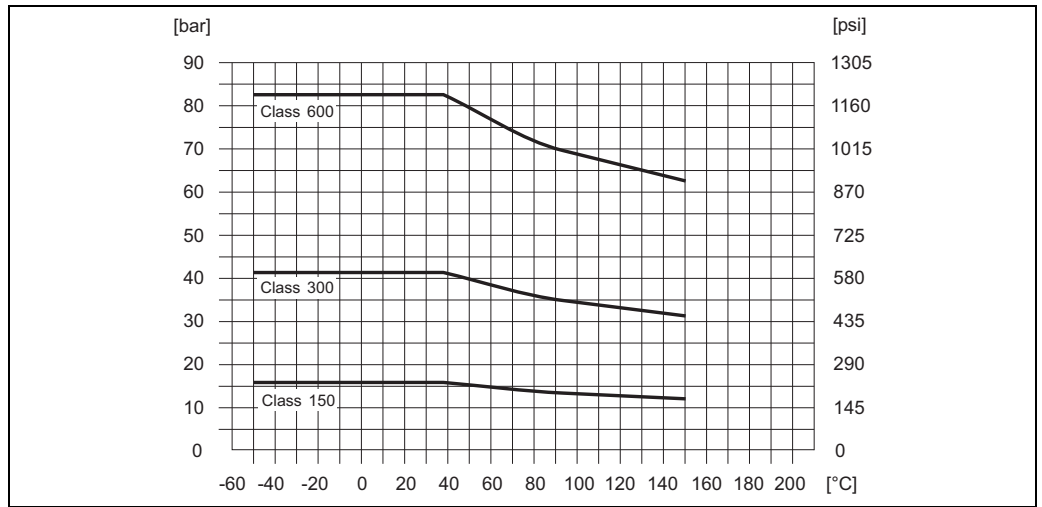

a0003297

Promass I: Flange connection to JIS B2238

Flange material: 1.4301/304
 Fluid wetted parts: titanium

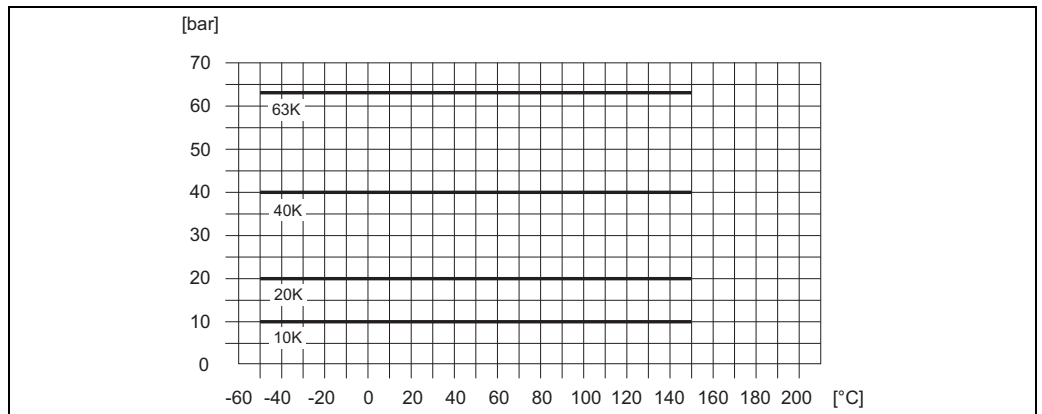

a0003304

Promass I: Sanitary connection to DIN 11851 / SMS 1145

Connection material: titanium

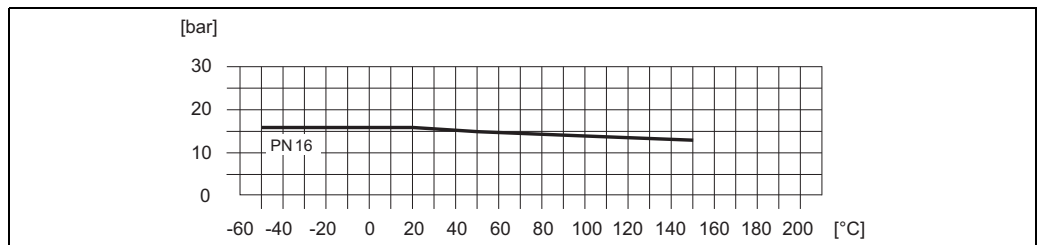

a0003305

Promass I: Tri-Clamp process connection

The load limit is defined exclusively by the material properties of the outer clamp used. This clamp is not included in the scope of delivery.

Promass I: Coupling to DIN 11864-1

Connection material: titanium

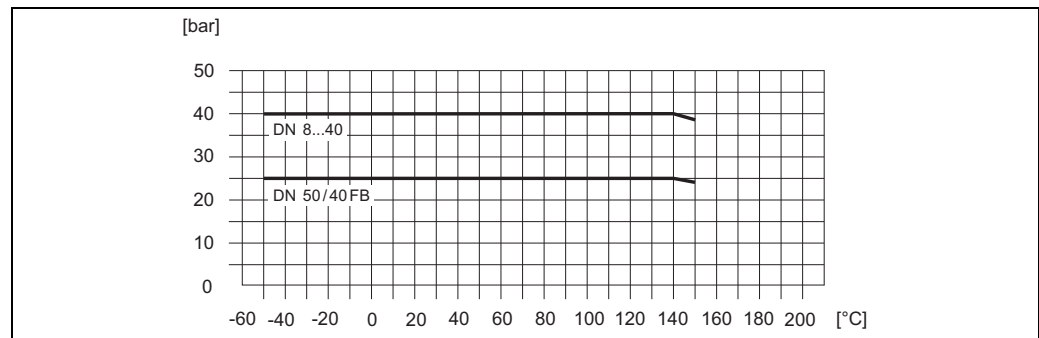

a0003306

Promass I: Flange connections to DIN 11864-2 Form A (flat flange)

Connection material: titanium

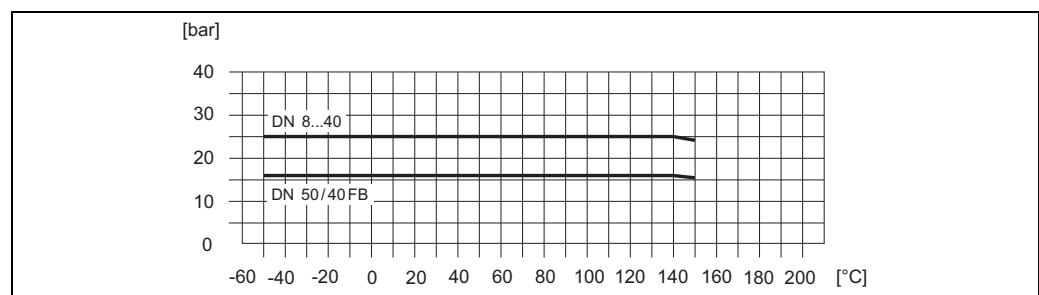

a0003307

Promass I: Coupling to ISO 2853

Connection material: titanium

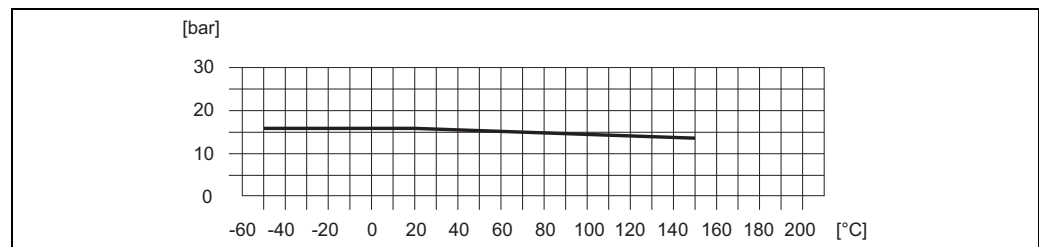

a0003308

Process connections

Promass H (welded process connections):

- Flanges EN 1092-1 (DIN 2501), ANSI B16.5, JIS B2238

Promass I (welded process connections):

- Flanges EN 1092-1 (DIN 2501), ANSI B16.5, JIS B2238
- Sanitary connections: Tri-Clamp, couplings (DIN 11851, SMS 1145, ISO 2853, DIN 11864-1), flange to DIN 11864-2 Form A (flat flange)

Human interface

Display elements	<ul style="list-style-type: none"> ■ Liquid-crystal display: backlit, two lines (Promass 80) or four lines (Promass 83) with 16 characters per line ■ Selectable display of different measured values and status variables ■ At ambient temperatures below -20 °C the readability of the display may be impaired.
-------------------------	--

Unified control concept for both types of transmitter:	<p>Promass 80:</p> <ul style="list-style-type: none"> ■ Local operation with three keys (-, +, E) ■ Quick Setup menus for straightforward commissioning <p>Promass 83:</p> <ul style="list-style-type: none"> ■ Local operation with three optical keys (□/□/□) ■ Application-specific Quick Setup menus for straightforward commissioning
---	--

Language groups	<p>Note! The language group is changed using the “ToF Tool – Fieldtool Package” operating program.</p> <p>Language groups available for operation in different countries:</p> <ul style="list-style-type: none"> ■ Western Europe and America (WEA): English, German, Spanish, Italian, French, Dutch and Portuguese ■ Eastern Europe/Scandinavia (EES): English, Russian, Polish, Norwegian, Finnish, Swedish and Czech ■ South and Eastern Asia (SEA): English, Japanese, Indonesian <p>Only Promass 83:</p> <ul style="list-style-type: none"> ■ China (CN): English, Chinese
------------------------	---

Remote operation	<p>Promass 80:</p> <p>Remote operation via HART, PROFIBUS PA</p> <p>Promass 83:</p> <p>Remote operation via HART, PROFIBUS PA/DP, FOUNDATION fieldbus</p>
-------------------------	---

Certificates and approvals

CE mark	<p>The measuring system is in conformity with the statutory requirements of the EC Directives. Endress+Hauser confirms successful testing of the device by affixing to it the CE mark.</p>
C-Tick symbol	<p>The measuring system complies with the EMC requirements of the “Australian Communications Authority (ACA)”.</p>
Ex approval	<p>Information about currently available Ex versions (ATEX, FM, CSA etc.) can be supplied by your Endress+Hauser Sales Center on request. All information relevant to explosion protection is available in separate Ex documents that you can order as necessary.</p>
Sanitary compatibility	<ul style="list-style-type: none"> ■ 3A approval ■ EHEDG tested

FOUNDATION Fieldbus certification	<p>The flow device has successfully passed all the test procedures carried out and is certified and registered by the Fieldbus FOUNDATION. The device thus meets all the requirements of the following specifications:</p> <ul style="list-style-type: none"> ■ Certified to FOUNDATION Fieldbus Specification ■ The device meets all the specifications of the FOUNDATION Fieldbus H1. ■ Interoperability Test Kit (ITK), revision status 4.0 (device certification number: on request) ■ The device can also be operated with certified devices of other manufacturers ■ Physical Layer Conformance Test of the Fieldbus FOUNDATION
PROFIBUS DP/PA certification	<p>The flow device has successfully passed all the test procedures carried out and is certified and registered by the PNO (PROFIBUS User Organization). The device thus meets all the requirements of the following specifications:</p> <ul style="list-style-type: none"> ■ Certified in accordance with PROFIBUS Profile Version 3.0 (device certification number: available on request) ■ The device can also be operated with certified devices of other manufacturers (interoperability)
MODBUS certification	<p>The measuring device meets all the requirements of the MODBUS/TCP conformity test and has the “MODBUS/TCP Conformance Test Policy, Version 2.0”. The measuring device has successfully passed all the test procedures carried out and is certified by the “MODBUS/TCP Conformance Test Laboratory” of the University of Michigan.</p>
Other standards and guidelines	<ul style="list-style-type: none"> ■ EN 60529 Degrees of protection by housing (IP code) ■ EN 61010 Protection Measures for Electrical Equipment for Measurement, Control, Regulation and Laboratory Procedures. ■ EN 61326/A1 (IEC 1326) “Emission in accordance with Class A requirements”. Electromagnetic compatibility (EMC requirements) ■ NAMUR NE 21 Electromagnetic compatibility (EMC) of industrial process and laboratory control equipment. ■ NAMUR NE 43 Standardization of the signal level for the breakdown information of digital transmitters with analog output signal. ■ NAMUR NE 53 Software of field devices and signal-processing devices with digital electronics
Pressure Equipment Directive	<p>Measuring devices with a nominal diameter smaller than or equal to DN 25 correspond to Article 3(3) of the EC Directive 97/23/EC (Pressure Equipment Directive) and have been designed and manufactured according to good engineering practice. For larger nominal diameters, optional approvals according to Cat. II/III are available when required (depends on fluid and process pressure).</p>

Functional safety

SIL -2:
accordance IEC 61508/IEC 61511-1 (FDIS)
“4-20 mA” output according to the following order code:

Promass 80

Promass80***_*****A
Promass80***_*****D
Promass80***_*****S
Promass80***_*****T
Promass80***_*****8

Promass 83

Promass83***_*****A	Promass83***_*****M	Promass83***_*****O
Promass83***_*****B	Promass83***_*****R	Promass83***_*****2
Promass83***_*****C	Promass83***_*****S	Promass83***_*****3
Promass83***_*****D	Promass83***_*****T	Promass83***_*****4
Promass83***_*****E	Promass83***_*****U	Promass83***_*****5
Promass83***_*****L	Promass83***_*****W	Promass83***_*****6

Ordering information

The Endress +Hauser service organization can provide detailed ordering information and information on the order codes on request.

Accessories

Various accessories, which can be ordered separately from Endress+Hauser, are available for the transmitter and the sensor.

Note!

The Endress+Hauser service organization can provide detailed information on the order codes of your choice.

Documentation

- Flow measurement (FA005D/06/en)
- Technical Information Promass 80E, 83E (TI061D/06/en)
- Technical Information Promass 80/83 A (TI054D/06/en)
- Technical information Promass 80H, 80I, 83H, 83I (TI052D/06/en)
- Operating Instructions Promass 80 (BA057D/06/en)
- Operating Instructions Promass 80 PROFIBUS PA (BA072D/06/en)
- Operating Instructions Promass 83 (BA059D/06/en)
- Operating Instructions Promass 83 FOUNDATION Fieldbus (BA065D/06/en)
- Operating Instructions Promass 83 PROFIBUS DP/PA(BA063D/06/en)
- Operating Instructions Promass 83 MODBUS (BA107D/06/en)
- Description of Device Functions Promass 80 (BA058D/06/en)
- Description of Device Functions Promass 80 PROFIBUS PA (BA073D/06/en)
- Description of Device Functions Promass 83 (BA060D/06/en)
- Description of Device Functions Promass 83 FOUNDATION Fieldbus (BA066D/06/en)
- Description of Device Functions Promass 83, PROFIBUS DP/PA (BA064D/06/en)
- Description of Device Functions Promass 83 MODBUS (BA108D/06/en)
- Supplementary documentation on Ex-ratings: ATEX, FM, CSA
- Functional safety manual Promass 80, 83 (SD077D/06/en)

Registered trademarks

KALREZ® and VITON®

Registered trademarks of E.I. Du Pont de Nemours & Co., Wilmington, USA

TRI-CLAMP®

Registered trademark of Ladish & Co., Inc., Kenosha, USA

SWAGELOK®

Registered trademark of Swagelok & Co., Solon, USA

HART®

Registered trademark of HART Communication Foundation, Austin, USA

PROFIBUS®

Registered trademark of the PROFIBUS User Organization, Karlsruhe, Germany

FOUNDATION™ Fieldbus

Registered trademark of the Fieldbus FOUNDATION, Austin, USA

MODBUS®

Registered trademark of the MODBUS Organization

HistoROM™, S-DAT®, T-DAT™, F-CHIP®, ToF Tool - Fieldtool® Package, Fieldcheck®, Applicator®

Registered or registration-pending trademarks of Endress+Hauser Flowtec AG, Reinach, CH

International Headquarters

Endress+Hauser
GmbH+Co. KG
Instruments International
Colmarer Str. 6
79576 Weil am Rhein
Deutschland

Tel. +49 76 21 9 75 02
Fax +49 76 21 9 75 34 5
www.endress.com
info@ii.endress.com

Endress+Hauser 

People for Process Automation