

Technical Information

RMC621

Flow and Energy Manager

Universal flow and energy computer for gases, liquids and steam



Applications

- Energy management
- Chemical industry
- Heating and air conditioning
- Pharmaceutical industry
- Food and beverage
- Plant and panel manufacture
- Oil + petrochemicals

Features and benefits

- Suitable for applications with gas, liquid, steam and water
- Intrinsically safe input (optional)
- Simultaneous calculation of up to 3 measuring applications, even if different fluids are used
- Very precise process calculations (density, enthalpy, compressibility) on the basis of equations and/or storable tables with material data
- Calculation standards according to IAPWS-IF 97, SGERG88, AGA8, real gas equations (SRK, RK), ISO 5167, tables
- Can be used with all common flow measuring systems (vortex, turbine, MID, orifice plate, differential pressure, etc.)
- Profibus interface (optional)
- Compensation input for density signal

- Logbook function for error messages and parameter changes with date and time
- Configuration and operation using a PC ReadWin® 2000 software
- Modular expansion of inputs and outputs
- Large back-lit LCD with color change in the event of an error
- ATEX II (1) GD [EEx ia] IIC



Function and system design

Measuring principle

The RMC621 is a multifunctional flow and energy computer. It calculates standard & volumetric flow, mass flow and energy (heat) flow using input signals of flow, differential pressure, pressure, temperature and density. It satisfies requirements for gas (e.g. natural gas, air, steam, etc.) and liquid (e.g. heat transfer liquid, water, etc.) applications.

Calculation

- volumetric flow
- standard (corrected) flow
- mass flow
- heat flow
- energy differential

Sum (counter)

- volumetric flow
- standard (corrected) flow
- mass
- heat
- bidirectional volumetric/mass/energy flow

Input

- current (0/4 to 20 mA)
- PFM
- pulse
- temperature Pt100, Pt500 and Pt1000 in 3- or 4-wire system or with transmitter (e.g. TMT 181) with 4 to 20 mA signal

Output

- current (0/4 to 20 mA)
- pulse
- digital (passive)
- relay
- transmitter power supply for each analogue or pulse input

Note!

The number of inputs, outputs, relays and transmitter power supplies contained in the basic device can be individually increased using a maximum of three plug-in cards.

Calculation methods

The flow & energy calculator RMC621 incorporates compensation for flow, gas and fluid measurement according the following equations:

Gases

- Improved ideal gas law: flow correction in consideration of temperature, pressure and the mean value for compressibility.
- Real gas equation (SRK, RK) and possibility to edit tables for the calculation of compressibility and density of technical gases or density input.
- Natural gas using international standards **NX19**, **SGERG88** and **AGA8** (optional).

Liquids

- Density calculation with algorithms and tables.
- Constant heat capacity or table (heating value as a constant).
- Mineral oil density according to standards **ASTM 1250**, **API 2540**, **OIML R63** (optional).

Steam/water

- International calculation standard **IAPWS IF-97** (ASME tables).

Applications

Gas

Standard volume/mass/combustion heat

Calculation of the gas standard volume and the gas mass with the aid of the gas properties stored in the flow computer. The gas standard volume is determined by taking into account the pressure and temperature effect and the compressibility of the gas which describes the deviation of a gas from an ideal gas. The compressibility of the gas (z -factor) is determined using calculation standards or stored tables depending on the type of gas. As an option there is an input to measure the density directly. For combustibles the potential combustion heat is calculated using the mean heating value.

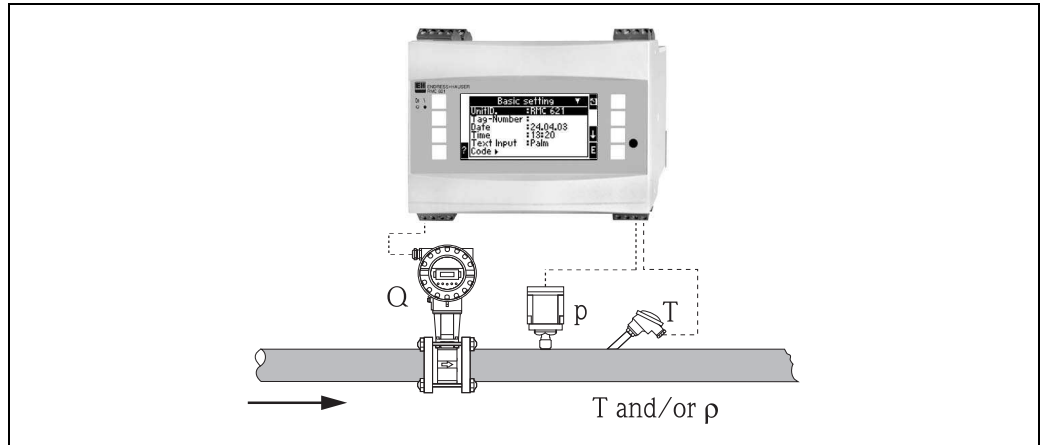

G09-RMC621ZZ-15-10-xx-en-000

Calculation of the gas standard volume/mass from the input variables flow (Q), pressure (p) and temperature (T) and/or density (ρ)

Liquid

Heat quantity/heat-differential

Calculation of the quantity of heat that is emitted or absorbed by a liquid flow in a heating or cooling system. The quantity of heat is calculated from the process variable for flow and the differential from the flow and return temperature. Bidirectional energy calculations, such as balancing systems with changing flow direction (charging/discharging the heat accumulator) are also possible. As an option there is an input to measure the liquid density directly. For combustibles the potential combustion heat is calculated using the mean heating value.

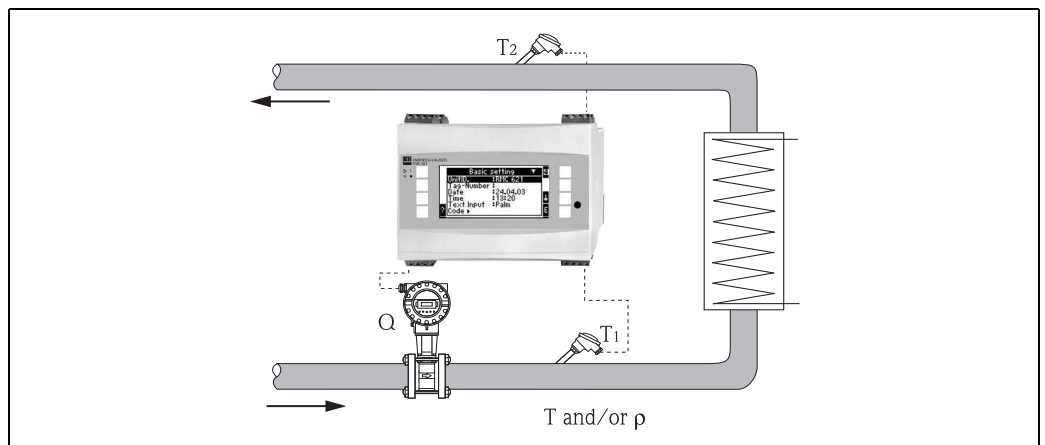

G09-RMC621ZZ-15-10-xx-en-000

Calculation of the water-quantity of heat and water-heat differential from the input variables flow (Q) and the temperature differential ($T_1 - T_2$) and/or density (ρ)

Steam

Mass/heat quantity/heat-differential

Calculation of the mass flow and its quantity of heat (energy) in a steam line from the process variables i. e. flow, pressure and temperature. In saturated steam operation, the mass flow is calculated from two input variables (pressure-compensated or temperature-compensated).

In addition the balancing of a steam generation process (phase transition: water → steam) or a steam heating process (phase transition: steam → water) is possible.

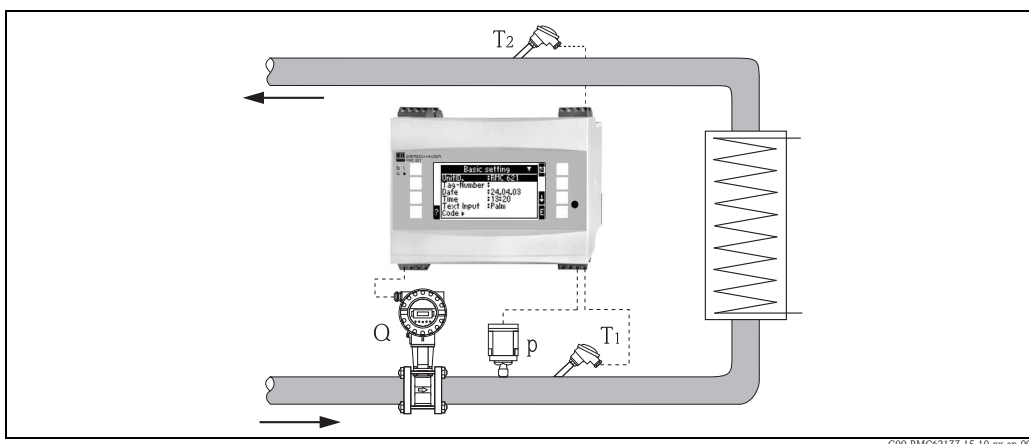

Calculation of steam-heat differential from the input variables for flow (Q), pressure (p) and temperature differential ($T_1 - T_2$)

Measuring system

The analog input variables are digitized, the pulse and PFM signals recorded using period length/frequency measurement and processed further in the arithmetic unit controlled by the microcontroller. The energy values are calculated depending on the medium and configuration using international standards (IAPWS-IF97, SGERG88), state equations (SRK) or specific tables. This guarantees maximum precision in all temperature ranges. The internal real time clock with back up power is used to integrate the flow values. Both the input variables and the results can be given out via the outputs.

With differential pressure measurement, the coefficients for flow compensation are calculated over the entire working range of the flow sensor.

Configuration of the inputs, outputs, limit values, the display as well as commissioning and maintenance of the device can be performed via 8 soft keys with the back-lit dot matrix display, using RS232/RS485 interface, ReadWin® 2000 PC software and an external control unit.

Online help makes on-site operation easier. The color change of the background lighting visualizes alarm value violations or faults. A functional expansion of the device by means of expansion cards can be made at any time.

Input

Measured variable	Current, PFM, pulse, temperature
Input signals	Flow, differential pressure, pressure, density
Measuring range	

Measured variable	Input
Current	<ul style="list-style-type: none"> ■ 0/4 to 20 mA +10% overreach ■ Max. input current 150 mA ■ Input impedance < 10 Ω ■ Accuracy 0.1% of full scale value ■ Temperature drift 0.04% / K (1.8 F) ambient temperature change ■ Signal attenuation low-pass filter 1st order, filter constants adjustable 0 to 99 s ■ Resolution 13 Bit ■ Fault recognition 3.6 mA or 21 mA limit as per NAMUR NE43 (see Breakdown Information to NAMUR NE43, page 5)
PFM	<ul style="list-style-type: none"> ■ Frequency range when using an input on the mainboard (Slot A): 0.25 Hz to 12.5 kHz ■ Frequency range when using an input on an extension board (Slot B, C, D): 0.01 Hz to 12.5 kHz ■ Signal level 2 to 7 mA low; 13 to 19 mA high ■ Measurement method: period length/frequency measurement ■ Accuracy 0.01% of measured value ■ Temperature drift 0.1% / 10 K (18 °F) ambient temperature change

Measured variable	Input												
Pulse	<ul style="list-style-type: none"> ■ Frequency range when using an input on the mainboard (Slot A): 0.25 Hz to 12.5 kHz ■ Frequency range when using an input on an extension board (Slot B, C, D): 0.01 Hz to 12.5 kHz ■ Signal level 2 to 7 mA low; 13 to 19 mA high with approx. 1.3 kΩ dropping resistor at max. 24 V voltage level 												
Temperature	Resistance thermometer (RTD) according to IEC 751 ($\alpha = 0.00385$):												
	<table border="1"> <thead> <tr> <th>Designation</th> <th>Measuring range</th> <th>Accuracy (4-wire connection)</th> </tr> </thead> <tbody> <tr> <td>Pt100</td> <td>-200 to 800 °C (-328 to 1472 °F)</td> <td>0.03% of full scale value</td> </tr> <tr> <td>Pt500</td> <td>-200 to 250 °C (-328 to 482 °F)</td> <td>0.1% of full scale value</td> </tr> <tr> <td>Pt1000</td> <td>-200 to 250 °C (-328 to 482 °F)</td> <td>0.08% of full scale value</td> </tr> </tbody> </table>	Designation	Measuring range	Accuracy (4-wire connection)	Pt100	-200 to 800 °C (-328 to 1472 °F)	0.03% of full scale value	Pt500	-200 to 250 °C (-328 to 482 °F)	0.1% of full scale value	Pt1000	-200 to 250 °C (-328 to 482 °F)	0.08% of full scale value
	Designation	Measuring range	Accuracy (4-wire connection)										
	Pt100	-200 to 800 °C (-328 to 1472 °F)	0.03% of full scale value										
	Pt500	-200 to 250 °C (-328 to 482 °F)	0.1% of full scale value										
Pt1000	-200 to 250 °C (-328 to 482 °F)	0.08% of full scale value											
<ul style="list-style-type: none"> ■ Type of connection: 3 or 4-wire system ■ Measuring current 500 μA ■ Resolution 16 Bit ■ Temperature drift 0.01% / 10 K (18 °F) ambient temperature change 													

Breakdown information to NAMUR NE43

Breakdown information is created when the measuring information is invalid or not present anymore and gives a complete listing of all errors occurring in the measuring system.

		Signal (mA)
Under ranging	Standard	3.8
Over ranging	Standard	20.5
Sensor break; sensor short circuit low	To NAMUR NE 43	≤ 3.6
Sensor break; sensor short circuit high	To NAMUR NE 43	≥ 21.0

Number:

- 2 x 0/4 to 20 mA/PFM/pulse (in basic device)
- 2 x Pt100/500/1000 (in basic device)

Maximum number:

- 10 (depends on the number and type of expansion cards)

Galvanic isolation

The inputs are galvanically isolated between the individual expansion cards and the basic device (see also 'Galvanic isolation' under Output).

Output

Output signal Current, pulse, transmitter power supply (TPS) and switching output

Galvanic isolation Basic device:

Connection with terminal designation	Power supply (L/N)	Input 1/2 0/4 to 20 mA/PFM/pulse (10/11) or (110/11)	Input 1/2 TPS (82/81) or (83/81)	Temperature input 1/2 (1/5/6/2) or (3/7/8/4)	Output 1/2 0 to 20 mA/pulse (132/131) or (134/133)	Interface RS232/485 housing front or (102/101)	TPS external (92/91)
Power supply		2.3 kV	2.3 kV	2.3 kV	2.3 kV	2.3 kV	2.3 kV
Input 1/2 0/4-20 mA/PFM/pulse	2.3 kV			500 V	500 V	500 V	500 V
Input 1/2 TPS	2.3 kV			500 V	500 V	500 V	500 V
Temperature input 1/2	2.3 kV	500 V	500 V		500 V	500 V	500 V
Output 1/2 0-20 mA/pulse	2.3 kV	500 V	500 V	500 V		500 V	500 V
Interface RS232/RS485	2.3 kV	500 V	500 V	500 V	500 V		500 V
TPS external	2.3 kV	500 V	500 V	500 V	500 V	500 V	

Note!

The specified insulation voltage is the AC testing voltage U_{eff} , which is applied between the connections. Basis for assessment: IEC 61010-1 (EN 61010-1), protection class II, overvoltage category II. Outputs in the same slot are not galvanically isolated.

Current - pulse output variable

- Current**
- 0/4 to 20 mA +10% overreach, invertible
 - Max. loop current 22 mA (short-circuit current)
 - Load max. 750 Ω at 20 mA
 - Accuracy 0.1% of full scale value
 - Temperature drift: 0.1% / 10 K (18 °F) ambient temperature change
 - Output Ripple < 10 mV at 500 Ω for frequencies < 50 kHz
 - Resolution 13 Bit
 - Error signals 3.6 mA or 21 mA limit adjustable as per NAMUR NE43 (see current inputs, page 5)

- Pulse**
- Basic device:
- Frequency range to 12.5 kHz (18 kHz - version intrinsically safe)
 - Voltage level 0 to 1 V low, 24 V high $\pm 15\%$
 - Load min. 1 k Ω
 - Pulse width 0.04 to 1000 ms
- Expansion cards (digital passive, open collector):
- Frequency range to 12.5 kHz (18 kHz - version intrinsically safe)
 - $I_{\text{max.}} = 200$ mA
 - $U_{\text{max.}} = 24$ V $\pm 15\%$
 - $U_{\text{low/max.}} = 1.3$ V at 200 mA
 - Pulse width 0.04 to 1000 ms

Number	Number: ■ 2 x 0/4 to 20 mA/pulse (in basic device) Max. number: ■ 8 x 0/4 to 20 mA/pulse (depends on the number of expansion cards) ■ 6 x digital passive (depends on the number of expansion cards)
---------------	--

Signal sources	All available multifunctional inputs (current, PFM or pulse inputs) and results can be freely allocated to the outputs.
-----------------------	---

Switching output

Function	Limit relay switches in these operating modes: minimum, maximum safety, gradient, alarm, saturated steam alarm, frequency/pulse, device error
-----------------	---

Switch behavior	Binary, switches when the alarm value is reached (potential-free NO contact)
------------------------	--

Relay switching capacity	Max. 250 V AC, 3 A / 30 V DC, 3 A Note! When using relays on expansion cards, a mixture of low voltage and extra-low voltage is not permitted.
---------------------------------	--

Switching frequency	Max. 5 Hz
----------------------------	-----------

Switching threshold	Programmable (wet steam alarm is preset at 2 °C / 3.6 °F at the factory)
----------------------------	--

Hysteresis	0 to 99%
-------------------	----------

Signal source	All available inputs and calculated variables can be allocated freely to the switching outputs.
----------------------	---

Number	1 (in basic device) Max. number: 7 (depends on the number and type of expansion cards)
---------------	---

Number of output states	100,000
--------------------------------	---------

Scan rate	500 ms
------------------	--------

Transmitter power supply and external power supply

- Transmitter power supply unit, terminals 81/82 or 81/83 (optional universal expansion cards 181/182 or 181/183):
 Maximum supply voltage 24 V DC \pm 15%
 Impedance < 345 Ohm
 Maximum output current 22 mA (for $U_{out} > 16$ V)
- Technical data Energy manager:
 HART[®] communication is not impaired
 Number: 2 (in basic device)
 Maximum number: 8 (depending on the number and type of expansion cards).
- Additional power supply (e.g. external display), terminals 91/92:
 Supply voltage 24 V DC \pm 5%
 Max. current 80 mA, short-circuit proof
 Number 1
 Source resistance < 10 Ω

Power supply

Electrical connection (wiring diagrams)

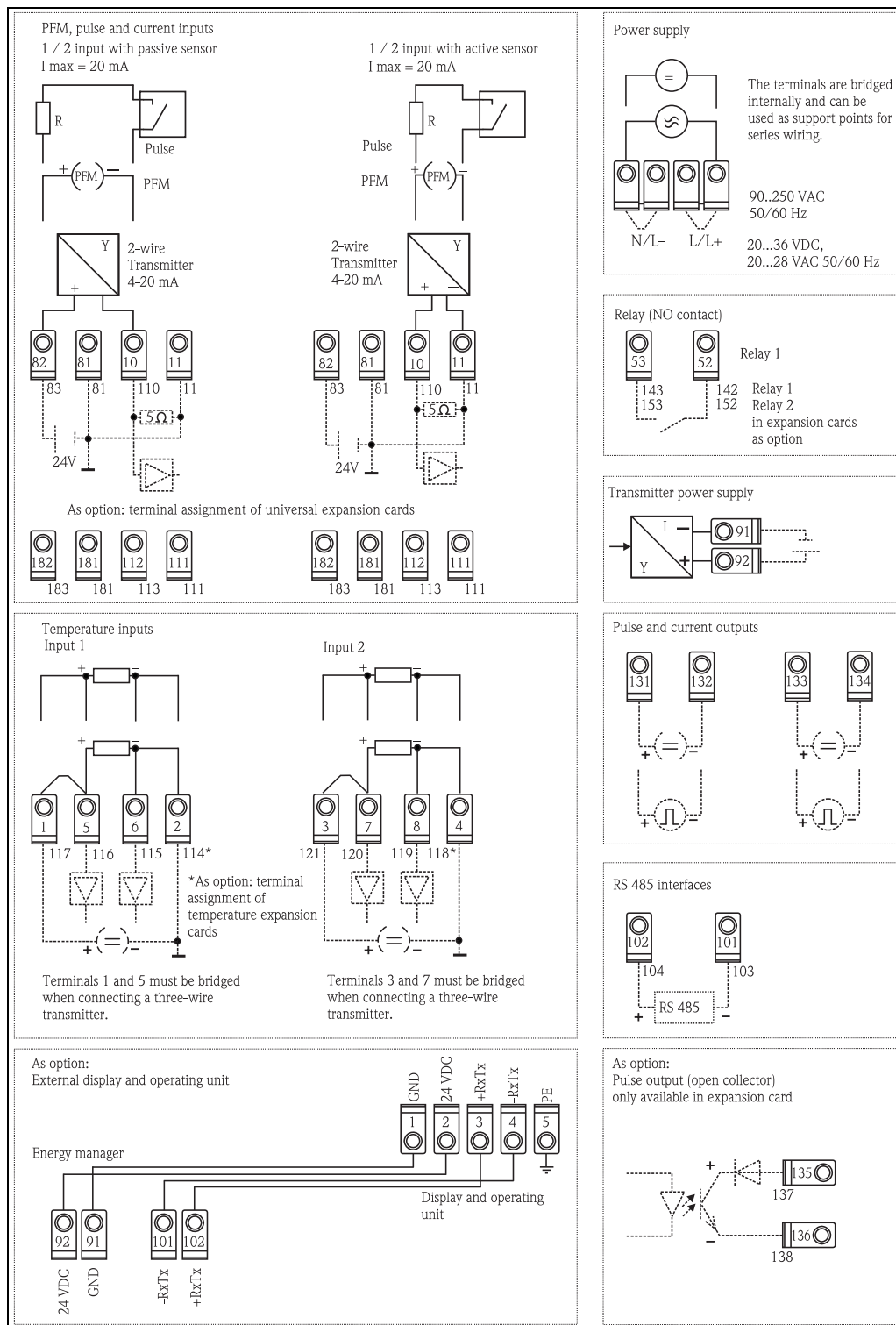

RMC621 terminal assignment - basic device + expansion cards (optional)

Supply voltage

- Low voltage power unit: 90 to 250 V AC 50/60 Hz
- Extra-low voltage power unit: 20 to 36 V DC or 20 to 28 V AC 50/60 Hz

Power consumption

8 to 26 VA (dependent on the expansion stage)

Connection data interface**RS232**

- Connection: 3.5 mm (0.14 in) jack plug on front panel
- Transmission protocol: ReadWin® 2000
- Transmission rate: max. 57,600 Baud

RS485

- Connection: plug-in terminals 101/102 (in basic device)
- Transmission protocol: (serial: ReadWin® 2000; parallel: open standard)
- Transmission rate: max. 57,600 Baud

Optional: additional RS485 interface

- Connection: plug-in terminals 103/104
- Transmission protocol and transmission rate same as standard RS485 interface

Performance characteristics

Reference operating conditions

- Power supply 230 V AC $\pm 10\%$; 50 Hz ± 0.5 Hz
- Warm-up period > 30 min
- Ambient temperature range 25 °C ± 5 °C (77 °F ± 9 °F)
- Air humidity 39% $\pm 10\%$ r. h.

Arithmetic unit

Medium	Variable	Range
Liquids	Temperature measuring range	-200 to 800 °C (-328 to 1472 °F)
	Maximum temperature differential range ΔT	0 to 1000 K (0 to 1800 °F)
	Error limit for ΔT	3 to 20 K (5.4 to 36 °F) < 1.0% of measured value 20 to 250 K (36 to 450 °F) < 0.3% of measured value
	Arithmetic unit accuracy class	Class 4 (as per EN 1434-1 / OIML R75)
	Measurement and calculation interval	500 ms
Steam	Temperature measuring range	0 to 800 °C (32 to 1472 °F)
	Pressure measuring range	0 to 1000 bar (0 to 14,500 psi)
	Measurement and calculation interval	500 ms
Techn. gas	Temperature measuring range	-137 to 800 °C (-215 to +1472 °F)
	Pressure measuring range	0 to 500 bar (0 to 7250 psi)
	Measurement and calculation interval	500 ms
Natural gas	Temperature measuring range	-40 to 200 °C (-40 to +392 °F; Nx-19) -60 to 200 °C (-76 to 392 °F; SGerg88)
	Pressure measuring range	0 to 120 bar (0 to 1740 psi)
	Measurement and calculation interval	500 ms

Installation conditions

Installation instructions

Mounting location

In the cabinet on DIN rail according to IEC 60715 TH 35

Caution!

When using extension cards, venting with an air current of at least 0.5 m/s is necessary.

Orientation

no restrictions

Environmental conditions

Ambient temperature

-20 to 60 °C (-4 to 140 °F)

Storage temperature

-30 to 70 °C (-22 to 158 °F)

Climate class

as per IEC 60 654-1 Class B2 / EN 1434 Class 'C'

Degree of protection

- Basic device: NEMA 1 (IP 20)
- External display: NEMA 4X (IP 65)

Electrical safety

Ambient < 2000 m (6560 ft) height above sea level

Electromagnetic compatibility

NAMUR NE21

This recommendation is an uniform and practical way of determining whether the devices used in laboratory and process control are immune to interference with an objective to increase its functional safety.

Interference emission

IEC 61326 (EN 61326 Class A)

Interference immunity

- Power failure: 20 ms, no influence
- Starting current limitation: $I_{\max}/I_n \leq 50\%$ ($T50\% \leq 50$ ms)
- Electromagnetic fields: 10 V/m as per IEC 61000-4-3
- Conducted HF: 0.15 to 80 MHz, 10 V as per IEC 61000-4-3
- Electrostatic discharge: 6 kV contact, indirect as per IEC 61000-4-2
- Burst (power supply): 2 kV as per IEC 61000-4-4
- Burst (signal): 1 kV/2 kV as per IEC 61000-4-4
- Surge (AC power supply): 1 kV/2 kV as per IEC 61000-4-5
- Surge (DC power supply): 1 kV/2 kV as per IEC 61000-4-5
- Surge (signal): 500 V/1 kV as per IEC 61000-4-5

Mechanical construction

Design, dimensions

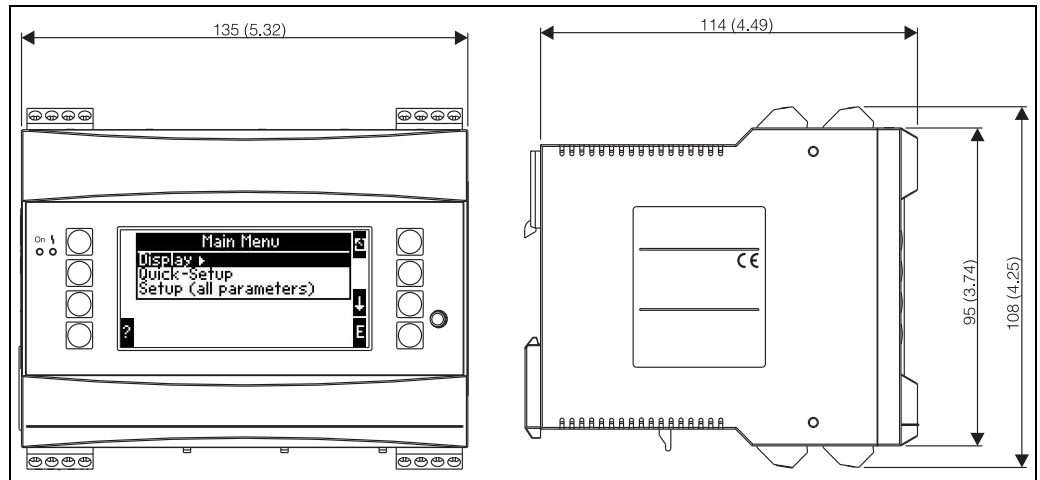

Housing for DIN rail as per IEC 60715 TH 35; dimensions in mm (inches)

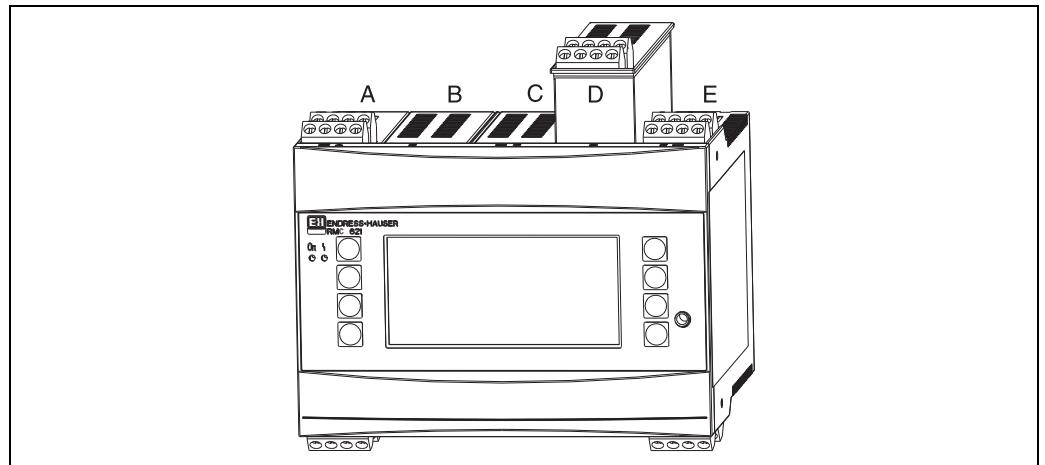

RMC621 upgrade with expansion cards (optional or available as accessories)

- Slots A and E equipped in the basic device
- Slots B, C and D can be upgraded with expansion cards

Weight

- Basic device: 500 g (1.1 lb) in maximum configuration with expansion cards
- Remote control unit: 300 g (0.7 lb)

Material

Housing: polycarbonate plastic, UL 94V0

Terminals

Coded, pluggable screw terminals; Clamping area 1.5 mm² (16 AWG) solid, 1.0 mm² (18 AWG) flexible with wire end ferrule (applies to all connections).

Human interface

Display elements

- Display (optional):
160 x 80 Dot-matrix LCD with blue background lighting
Color changes to red in the event of an error (adjustable)
- LED status display:
Operation: 1 x green (2 mm; 0.079")
Fault message: 1 x red (2 mm; 0.079")
- External display and operating unit (optional or as accessory):
A display and operating unit can also be connected to the energy manager in the panel mounted housing, dimensions (W x H x D) 144 mm (5.7") x 72 mm (2.84") x 43 mm (1.7"). The connection to the integrated RS485 interface is made using the connecting cable (l = 3 m / 10 ft), which is included in the accessories set. Parallel operation of the external display unit with a device-internal display in the RMC621 is possible.

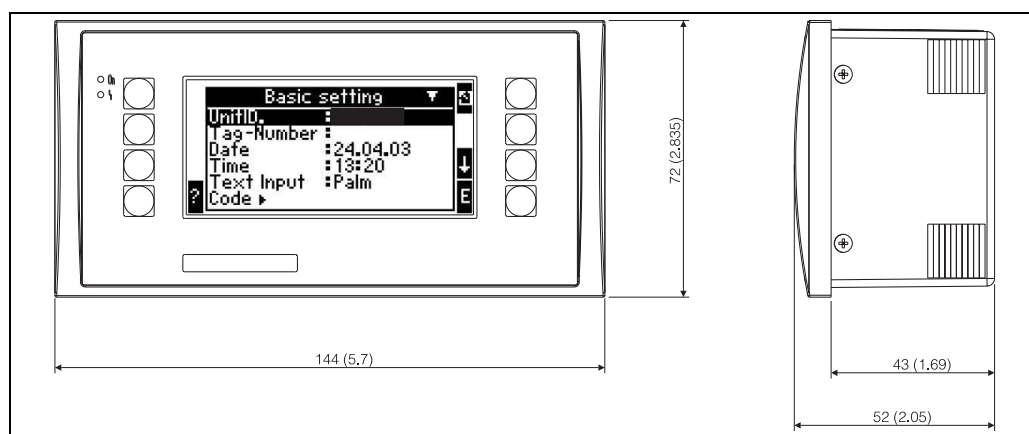

External display and operating unit for panel mounting (optional or available as accessory); dimensions in mm (inches)

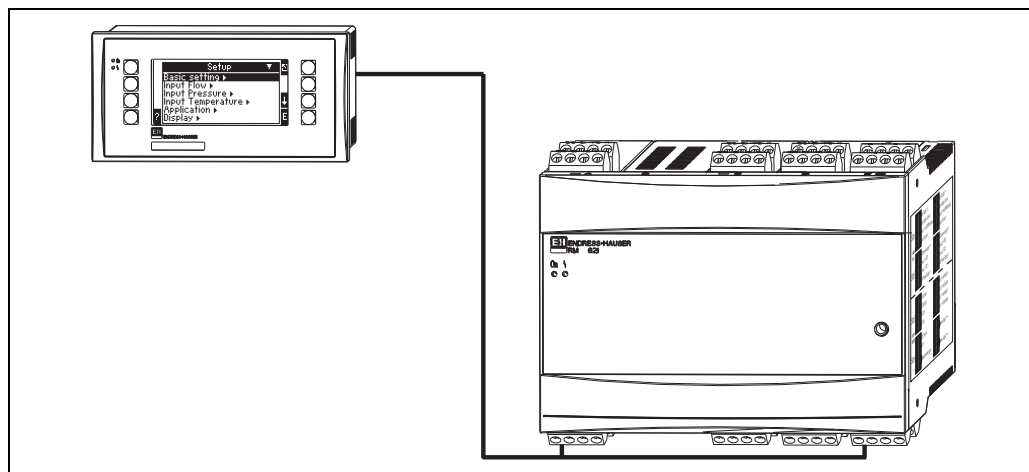

External display and operating unit in the panel mounted housing

Operating elements

Eight front-panel soft keys interact with the display (function of the keys is shown in the display).

Remote operation

RS232 interface (3.5 mm / 0.14") jack plug on front panel); configuration via PC with ReadWin® 2000 PC operating software. RS485 interface.

Real time clock	<ul style="list-style-type: none">■ Deviation: 30 min per year■ Power reserve: 14 days
Mathematical functions	<p>Flow, differential pressure calculation: EN ISO 5167 Continuous calculation of mass, standard volume, density, enthalpy, quantity of heat using stored algorithms and tables.</p> <ul style="list-style-type: none">■ Water / steam: IAWPS-IF97■ Liquids: linear density function and tables for density and heat capacity Mineral oil: API 2540, ASTM 1250, OIML R63■ Technical gases: real gas equations (Soave Redlich Kwong), compressibility tables as well as improved ideal gas equation■ Natural gas: NX19, as option: SGERG88, AGA8 (gross-method) <p>Tables for density, heat value and compressibility can be edited freely or saved.</p>

Certificates and approvals

CE mark	The measurement system fulfills the requirements demanded by the EU regulations. Endress+Hauser acknowledges successful unit testing by adding the CE mark.
Hazardous area approvals	ATEX II (1) GD [EEx ia] IIC FM IS Class I, II, III; Div. 1, Grps. A-F (consult factory for availability) CSA (Ex ia), Class I, II, III; Div. 1, Grps. A-F (consult factory for availability)
Other standards and guidelines	<ul style="list-style-type: none">■ IEC 60529 (EN 60529): Degrees of protection by housing, ANSI/NEMA 250 Enclosures for Electrical Equipment (IP-Code).■ IEC 61010 (EN 61010:) Safety requirements for electrical measurement, control and laboratory instrumentation.■ IEC 61326 (EN 61326:) Electromagnetic compatibility (EMC requirements).■ NAMUR NE21, NE43 Standardization association for measurement and control in chemical and pharmaceutical industries (www.namur.com).■ IAWPS-IF 97 International applicable and recognized calculation standard (since 1997) for steam and water. Issued by the International Association for the Properties of Water and Steam (IAPWS).■ OIML R75 International construction regulation and test specification for water energy managers from the Organisation Internationale de Métrologie Légale.■ EN 1434-1, 2, 5 and 6■ EN ISO 5167 Flow measurement of fluids with throttle devices.

Ordering information

Product structure

RMC621	Energy manager For calculating of flow, heat quantity and heat differential of gases, fluids, steam/water; Gas and fluid tables Calculation formula to IAPWS-IF97 for steam/water; according to SGERG, AGA8, SRK, RK for gases. Inputs A: 2 x 0/4 to 20 mA/PFM/pulse with loop power Inputs E: 2 x Pt100/500/1000 Output A: 1 x Relay (closing cont.), 1 x loop power Outputs E: 2 x 0/4 to 20 mA/pulse
	Version
A	Non-hazardous area
B	ATEX II(1)GD EEx ia IIC
C	FM AIS I,II,III/1/ABCDEF
D	CSA (Ex ia) I,II,III/1/ABCDEF
E	NEPSI (Ex ia) IIC
	Operation
1	Software ReadWin 2000, w/o button
2	Alphanumeric display; 8 button
3	Panel 72x144mm; RS485
4	Panel 72x144mm, 2x RS485
	Power supply
1	90-250VAC
2	20-36VDC, 20-28VAC
	Slot B:
A	not selected
B	Input 2x 0/4-20mA/PFM/pulse + 2x loop power supply; Output 2x 0/4-20mA/pulse, 2x digital, 2x relay SPST
C	Input 2x Pt100/500/1000; Output 2x 0/4-20mA/pulse, 2x digital, 2x relay SPST
D	Input Ex-i, 2x 0/4-20mA/PFM pulse + loop power supply; Output 2x 0/4-20mA/pulse, 2x digital, 2x relay SPST
E	Input Ex-i, 2x Pt100/500/1000; Output 2x 0/4-20mA/pulse; 2x digital, 2x relay SPST
	Slot C fitted with:
A	not selected
B	Input 2x 0/4-20mA/PFM/pulse + 2x loop power supply; Output 2x 0/4-20mA/pulse, 2x digital, 2x relay SPST
C	Input 2x Pt100/500/1000; Output 2x 0/4-20mA/pulse, 2x digital, 2x relay SPST
D	Input Ex-i, 2x 0/4-20mA/PFM pulse + loop power supply; Output 2x 0/4-20mA/pulse, 2x digital, 2x relay SPST
E	Input Ex-i, 2x Pt100/500/1000; Output 2x 0/4-20mA/pulse; 2x digital, 2x relay SPST
	Slot D fitted with:
A	not selected
B	Input 2x 0/4-20mA/PFM/pulse + 2x loop power supply; Output 2x 0/4-20mA/pulse, 2x digital, 2x relay SPST
C	Input 2x Pt100/500/1000; Output 2x 0/4-20mA/pulse, 2x digital, 2x relay SPST
D	Input Ex-i, 2x 0/4-20mA/PFM pulse + loop power supply; Output 2x 0/4-20mA/pulse, 2x digital, 2x relay SPST
E	Input Ex-i, 2x Pt100/500/1000; Output 2x 0/4-20mA/pulse; 2x digital, 2x relay SPST
	software
1	Basic version
2	Basic version + SGERG(88)/AGA8
3	Basic version + API2540/ASTM
4	Basic version + SGERG(88)/AGA8 + API2540/ASTM D1250/OIML R63
Y	Other
RMC621-	← order code (part 1)

										Operation language	
										A	German
										B	English
										C	French
										D	Italian
										E	Spanish
										F	Dutch
										G	Polish
										H	American
										K	Czech
										Communication	
										1	1 x RS232 + 1 x RS485
										2	1 x RS232 + 1 x RS485 + cable + software ReadWin® 2000
										3	1 x RS232 + external Profibus-DP slave module
										4	1 x RS232 + external Profibus-DP slave module + cable + software ReadWin® 2000
										5	1 x RS232 + 2 x RS485 (not available with external display via 2. RS485)
										6	1 x RS232 + 2 x RS485 + cable + software ReadWin® 2000 (not available with external display via 2. RS485)
										7	1x RS232 + 1x RS485 + 1x M-Bus
										8	1x RS232 + 1x RS485 + 1x M-Bus + cable + software readwin
										A	1x RS232 + 1x RS485 + 1x ModBus
										B	1x RS232 + 1x RS485 + 1x ModBus + cable + software Readwin
										Additional option	
										1	Basic version
										2	Works calib. certif., 5-point
										K	DIN rail installation kit
RMC621-										← order code (complete)	

Product structure selection aid The following table contains an overview of the order codes for the expansion cards with the possible applications in an RMC621 energy manager:

Applications in a device	Number of inputs	Product structure (expansion cards)
1 x Saturated steam measurement	1 x Flow pulse 1 x 4 to 20 mA pressure	RMC621-xxxAAAxxxx
1 x Gas standard volume	1 x 4 to 20 mA flow 1 x 4 to 20 mA pressure 1 x Pt100 temperature	
1 x Liquid-heat differential	1 x 4 to 20 mA flow 2 x Pt100 temperature	
2 x Saturated steam	2 x Flow pulse 2 x 4 to 20 mA pressure	RMC621-xxxBAxxxx
1 x Gas standard volume 1 x Steam-quantity of heat	2 x PFM flow 2 x 4 to 20 mA pressure 2 x Pt500 temperature	
1 x Saturated steam measurement 1 Water-quantity of heat	2 x Flow pulse 1 x 4 to 20 mA pressure 2 x Pt100 temperature	
2 x Liquid-quantity of heat	2 x 4 to 20 mA flow 4 x Pt100 temperature	RMC621-xxxCAAxxxx
1 x Gas standard volume 1 x Liquid-heat differential	2 x 4 to 20 mA flow 4 x Pt100 temperature	
3 x Saturated steam measurement	3 x Flow pulse 3 x 4 to 20 mA pressure	RMC621-xxxBBxxxx
1 x Steam-quantity of heat 1 x Water-heat differential	1 x PFM flow 1 x Flow pulse 1 x 4 to 20 mA pressure 3 x Pt100 temperature	RMC621-xxxBCxxxx
1 x Steam-heat differential 1 x Water-heat differential	2 x PFM flow 1 x 4 to 20 mA pressure 4 x Pt100 temperature	
1 x Gas standard volume 1 x Net steam quantity of heat 1 x Liquid-quantity of heat	3 x PFM flow 2 x 4 to 20 mA pressure 4 x Pt100 temperature	RMC621-xxxBBCxxxx
3 x Steam mass	3 x 4 to 20 mA flow 3 x 4 to 20 mA pressure 3 x Pt500 temperature	
3 x Gas standard volume	3 x 4 to 20 mA flow 3 x 4 to 20 mA pressure 3 x Pt500 temperature	
1 x Steam mass 2 x Water-heat differential	3 x PFM flow 1 x 4 to 20 mA pressure 5 x Pt100 temperature	RMC621-xxxBCCxxxx
3 x Water-heat differential	3 x Flow pulse 6 x Pt100 temperature	

Accessories

- PC configuration software ReadWin® 2000 and serial configuration cable with 3.5 mm (0.138 in) jack plug.
Order No.: RMC621A-VK
- External display and operating unit in the panel mounted housing 144 x 72 x 43 mm (5.7 x 2.84 x 1.7 inches)
Order No.: RMC621A-AA
- NEMA 4 (IP 66) protective housing for field mounting DIN rail instrumentation
Order No.: 52010132
- Profibus interface
Order No.: RMC621A-P1

Expansion cards

A function expansion of the device by means of max. 3 extension cards (universal and/or temperature cards) is possible.

Extension card temperature Input: 2 x Pt100/500/1000 Output: 2 x 0/4 to 20 mA/pulse, 2 x digital, 2 x relays	Order No.: RMC621A-TA
Extension card universal Input: 2 x 0/4 to 20 mA/PFM/pulse with transmitter power supply Output: 2 x 0/4 to 20 mA/Pulse, 2 x digital, 2 x relays	Order No.: RMC621A-UA

Documentation

- Brochure 'System Components - Indicators with control unit for field and panel mounting, power supplies, barriers, transmitters, energy managers and surge arresters' (FA016K/09)
- Operating manual 'Energy Manager RMC621' (BA144R/09)

Instruments International

Endress+Hauser
Instruments International AG
Kaegenstrasse 2
4153 Reinach
Switzerland

Tel. +41 61 715 81 00
Fax +41 61 715 25 00
www.endress.com
info@ii.endress.com

Endress+Hauser 
People for Process Automation